

## H-Series™ Universal Header Hanger

Connect box headers to jambs or beams to columns.

The H-Series™ universal header hanger is used to connect box headers to jambs or beams to columns and transfer large vertical loads. This universal hanger is designed so one part can be used for either side of the connection. The hanger also features a support tab for proper alignment and easy installation.

The H-Series hanger is also prepunched with a series of round, square and triangle holes to ensure proper fastener placement for specified loads.

### ALTERNATIVE PRODUCTS

HDS® Framing System, HDSC Header Bracket, GP-Series™ Unpunched Gusset Plate

### PRODUCT DIMENSIONS

6" x 8-1/2"

### MATERIAL SPECIFICATIONS

**Gauge:** 18 gauge (43mils)

**Design Thickness:** 0.0451 inches

**Gauge:** 16 gauge (54mils)

**Design Thickness:** 0.0566 inches

**Gauge:** 14 gauge (68mils)

**Design Thickness:** 0.0713 inches

**Coating:** G90

**Yield Strength:** 33ksi for 18 gauge

50ksi for 14 & 16 gauge

**ASTM:** A653/A653M

### INSTALLATION

Install the H-Series universal header hanger to the jamb studs with the required number of screws as needed to achieve required loading. Normally two connectors are required, one on each side of the header.

Position header on header support tabs and secure header to header hanger with number of fasteners required by design.

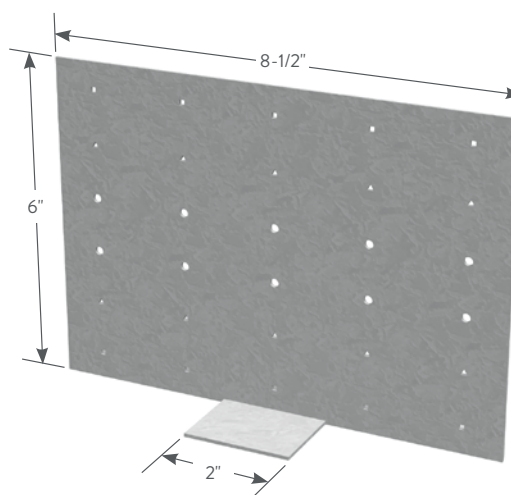

H-Series Universal Header Hanger

## H-Series™ Universal Header Hangers

Product code	Thickness		Size (in)	Packaging Pcs./Bucket
	Mils (Gauge)	Design thickness (in)		
H436	43mils (18ga)	0.0451	6 x 8-1/2	50
H546	54mils (16ga)	0.0566	6 x 8-1/2	50
H686	68mils (14ga)	0.0713	6 x 8-1/2	50

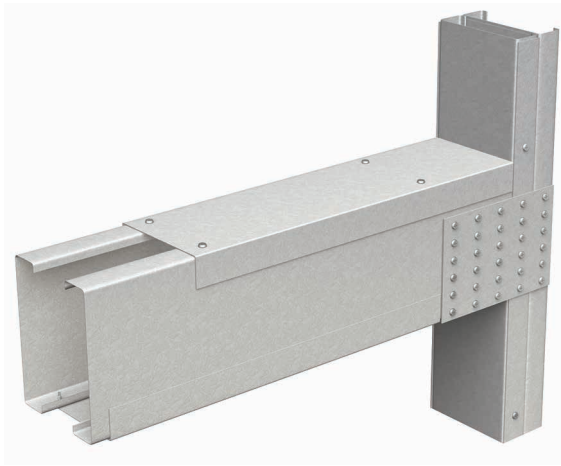

SCREW OPTIONS



(10) Screws  
(6) at Header (4) at Jamb



(20) Screws  
(12) at Header (8) at Jamb



(30) Screws  
(18) at Header (12) at Jamb

Allowable Loading Chart for Single Connectors

Connector	Framing Mils (Gauge)	Framing Fy (ksi)	10 Screws		20 Screws		30 Screws	
			Jamb capacity	Header capacity	Jamb capacity	Header capacity	Jamb capacity	Header capacity
H436 Using #10"-16" Screws	33mils (20ga)	33	561	307	1121	507	1361	637
	43mils (18ga)	33	832	455	1361	753	1361	945
	54mils (16ga)	33	832	455	1361	753	1361	945
		50	832	455	1361	753	1361	945
	68mils (14ga)	33	832	455	1361	753	1361	945
		50	832	455	1361	753	1361	945
97mils (12ga)	33	832	455	1361	753	1361	945	
	50	832	455	1361	753	1361	945	
H546 Using #10"-16" Screws	33mils (20ga)	33	561	307	1121	507	1682	637
	43mils (18ga)	33	832	455	1664	753	2496	945
	54mils (16ga)	33	1172	641	2345	1061	2634	1332
		50	1682	919	2634	1522	2634	1910
	68mils (14ga)	33	1655	905	2634	1498	2634	1880
		50	1682	919	2634	1522	2634	1910
97mils (12ga)	33	1682	919	2634	1522	2634	1910	
	50	1682	919	2634	1522	2634	1910	
H686 Using 1/4"-14" Screws	33mils (20ga)	33	630	344	1260	570	1890	716
	43mils (18ga)	33	935	511	1870	846	2805	1062
	54mils (16ga)	33	1318	720	2635	1193	3821	1497
		50	1997	1091	3821	1807	3821	2268
	68mils (14ga)	33	1860	1017	3720	1684	3821	2113
		50	2818	1541	3821	2551	3821	3201
97mils (12ga)	33	2818	1541	3821	2551	3821	3201	
	50	2818	1541	3821	2551	3821	3201	

Notes:

- To determine the connection capacity, use the minimum value from the jamb and header columns. For instance, using an H686 for the 30-screw option with a 16 gauge, 50ksi jamb stud and a 12 gauge, 50ksi header, the allowable load per plate is 3201 lbs (i.e., the minimum of 3821 lbs for the jamb and 3201 lbs for the header).
- For the H436 and the H546, the tabulated capacity is based on #10-16 screws with an ultimate screw shear capacity of 1400 lbs per screw. For the H686, the tabulated capacity is based on 1/4"-14 screws with an ultimate screw shear capacity of 2600 lbs per screw.
- H436 connectors are 33ksi, H546 and H686 connectors are 50ksi.
- Reference figures above for screw placement of the 10-, 20- and 30-screw options.
- Values are based on a minimum of (2) back-to-back jamb studs as shown above.

Typical Construction Details

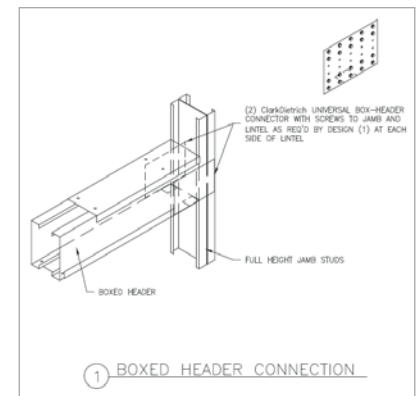

Visit our CAD Library at [clarkdietrich.com](http://clarkdietrich.com) to view or download construction details in .dwg, .dxf, and .pdf formats.