



**Kees Tazelaar**

# **On the Threshold of Beauty**

**Philips and the Origins  
of Electronic Music  
in the Netherlands  
1925–1965**

**Kees Tazelaar**

# **On the Threshold of Beauty**

**Philips and the Origins  
of Electronic Music  
in the Netherlands  
1925–1965**

*Dedicated to Dick Raaijmakers and Gottfried Michael Koenig*

# Contents

Foreword by Daniel Teruggi	7
Introduction	9

## Part I

### *Electroacoustics and Electronic Music at Philips Research Laboratories*

<b>1</b>	<b>Developments in Electroacoustics at Philips before 1945</b>	<b>17</b>
	<i>Philips Research Laboratories</i> · 17	
	<i>Radios and Loudspeaker Development</i> · 18	
	<i>Film Sound: The Loetafoon and the Film “Philips Radio”</i> · 22	
	<i>The Philips-Miller Recording System</i> · 26	
	<i>Stereophonic Sound</i> · 28	
	<i>Synthetic Sound</i> · 33	
	<i>The Philiolist Loudspeaker Violins</i> · 36	
<b>2</b>	<b>After World War II: Towards Electronic Music</b>	<b>38</b>
	<i>“Canned Music” and a Music Laboratory</i> · 38	
	<i>Collaboration with Leopold Stokowski</i> · 40	
	<i>Leopold Stokowski and Roelof Vermeulen at the Concertgebouw</i> · 45	
	<i>Multiplication of Concerts</i> · 50	
	<i>Ambiophonics and Reverberation</i> · 53	
	<i>The Gravesano Music and Electroacoustics Conference</i> · 59	
	<i>Electronic Musical Instruments for the Fair of Science</i> · 62	
<b>3</b>	<b>The Studio at Philips Research Laboratories</b>	<b>64</b>
	<i>Henk Badings and the Nederlandse Radio Unie</i> · 64	
	<i>Henk Badings’ “Kaïn en Abel” and the Studio Equipment in Room 306</i> · 66	
	<i>“Variations électroniques” and Philips’ Commercial Animation Films</i> · 72	
	<i>The Electronic Popular Music of Dick Raaijmakers, aka Kid Baltan</i> · 77	
	<i>Tom Dissevelt’s “Electronic Movements”</i> · 80	
	<i>More Electronic Music by Henk Badings</i> · 83	
	<i>Ton de Leeuw’s “Antiphonie” for Wind Quintet and Electronic Sounds</i> · 86	
	<i>The Composer Dick Raaijmakers</i> · 87	
	<i>The End of the Studio in Eindhoven</i> · 93	



## Part II

### ***Electronic Music for the Philips Pavilion***

<b>4 Preliminary Technical and Artistic Outline</b>	<b>101</b>
<i>Initial Concept</i> · 101	
<i>The Electroacoustics Division (ELA) and Its Studio</i> · 106	
<i>ELA at the 1958 World's Fair</i> · 109	
<i>Sound and Light Spectacles</i> · 111	
<b>5 Realizing the Music for the Philips Pavilion</b>	<b>114</b>
<i>Le Corbusier, Edgard Varèse, Iannis Xenakis: Artistic Considerations</i> · 114	
<i>Philips' Doubts about Edgard Varèse</i> · 118	
<i>The Garage at Strijp III and Willem Tak's Test Scenario</i> · 120	
<i>Edgard Varèse in Eindhoven and Preparations for Musical Production</i> · 127	
<i>The Laborious Recording of "Le poème électronique"</i> · 139	
<i>Anton Buczynski's Contribution</i> · 144	
<i>The Integration of Reverberation and Panning</i> · 147	
<i>Iannis Xenakis' "Interlude sonore"</i> · 153	
<b>6 <i>Le poème électronique</i> in Brussels</b>	<b>157</b>
<i>The Sound Installation</i> · 157	
<i>Edgard Varèse in Brussels</i> · 166	
<i>Presenting "Le poème électronique" to the Public</i> · 168	

## Part III

### ***Electronic Music Pervades Public Culture: Organizations, Studios, Concerts, Education***

<b>7 The First Steps towards a Dutch Electronic Music Studio</b>	<b>172</b>
<i>Walter Maas and the Founding of Gaudeamus</i> · 172	
<i>Werner Meyer-Eppler's Lectures</i> · 174	
<i>Electronic Music at the Nederlandse Radio Unie</i> · 175	
<b>8 An Organization for the Promotion of Electronic Music</b>	<b>177</b>
<i>The Contactorgaan Elektronische Muziek</i> · 177	
<i>Defining Electronic Music and Staging the First Concerts</i> · 180	
<i>The International Days of Experimental Music at the 1958 World's Fair</i> · 185	

<b>9</b>	<b>A Temporary Studio for Electronic Music Education and Production</b>	<b>188</b>
	<i>A Studio at Technische Hogeschool Delft</i> · 188	
	<i>Electronic Music for Film and Theater</i> · 192	
	<i>The Composers Jan Boerman and Rudolf Escher</i> · 197	
<b>10</b>	<b>Continuing the Work of the Philips and TH Delft Studios in Utrecht and Bilthoven</b>	<b>200</b>
	<i>Plans for New Studios in Utrecht and Amsterdam</i> · 200	
	<i>New Studios in Utrecht and Bilthoven</i> · 206	
	<i>Tom Dissevelt's "Intersection," Dick Raaijmakers' "Vijf plastieken,"</i> <i>Jan Boerman's "Alchemie 1961" and Rudolf Escher's</i> <i>"Summer Rites at Noon"</i> · 209	
	<i>The Battle over Leadership of the Studio in Utrecht</i> · 213	
	<i>Gottfried Michael Koenig at Gaudeamus: Critical Remarks on</i> <i>Sound Spatialization</i> · 219	
	<i>The Bilthoven Electronic Music Course</i> · 222	
	<i>The Utrecht Studio under Henk Badings and Rudolf Escher's</i> <i>Final Attempt</i> · 224	
	<i>Tom Dissevelt's "Fantasy in Orbit"</i> · 226	
<b>11</b>	<b>Private Projects</b>	<b>230</b>
	<i>The Mood Engineering Society</i> · 230	
	<i>The First Private Studios and Their Early Productions: Jan Boerman,</i> <i>Ton Bruynèl, Dick Raaijmakers</i> · 231	
<b>12</b>	<b>Towards Stability in Utrecht and The Hague</b>	<b>246</b>
	<i>Gottfried Michael Koenig's Formative Years</i> · 246	
	<i>Koenig at the Cologne Studio</i> · 250	
	<i>Koenig at STEM</i> · 255	
	<i>Kees van Baaren and the Establishment of a Studio at the</i> <i>Royal Conservatoire</i> · 262	
	<b>Acknowledgments</b>	<b>266</b>
	<b>List of Illustrations</b>	<b>268</b>
	<b>Notes</b>	<b>269</b>
	<b>References</b>	<b>296</b>
	<b>Appendix: Foreign Quotations in Original Languages</b>	<b>300</b>
	<b>Index</b>	<b>307</b>

# Foreword

by Daniel Teruggi

*Daniel Teruggi was the director of the Groupe de Recherches Musicales at the Institut National de l'Audiovisuel in France from 1997 until 2017.*

The short history of electroacoustic music contains a few unique moments that all composers, students and music lovers identify as landmarks; they have changed our perspective on this “recent” music. The Philips Pavilion at the 1958 World’s Fair in Brussels is one of them. This event brought together three of the great innovators of the twentieth century: Le Corbusier, a master of new architectural concepts; Edgard Varèse, the composer who introduced timbre as a major concept in instrumental music; and Iannis Xenakis, a composer and one of the finest thinkers on how music could be conceived in a different way.

In telling us their story, Kees Tazelaar describes forty years of the technical development and musical implications of what Dutch composers in 1956 decided to call “electronic music.” This book studies the evolution of the Philips company from its original engagement in making electrical technology and home devices through its interest in content and media to its conception of a special lab for work relating to technology’s effects on media, sound and music in its practice and creation. Tazelaar discovered that on the one hand there was strong research activity at Philips regarding the investigation of the potential of electroacoustic technology; however, to our great surprise, it was not this department that launched the Philips Pavilion project but the company’s commercial arm, which wanted a showroom for Philips technology.

Tazelaar’s story delves into the strong links between technical developments and musical concepts as well as into the complexity of relationships between composers and technicians and between composers themselves, in which musical ideals were strongly affected by rivalries and moral positions. *On the Threshold of Beauty* is a history of people – the passionate, the inventive, and those simply curious to see how technology could produce previously unheard and unseen musical and sonic environments. Researchers and technicians developed ingenious means of responding to composers’ wishes, and these new machines opened new creative vistas, which in turn pushed composers and musicians to imagine new possibilities for the expansion of technology.

Dutch composers and institutions encountered considerable difficulties in making a place for themselves within the international electroacoustic scene, mainly controlled in the 1950s by the *musique concrète* group in Paris, with Pierre Schaeffer at its head, and the *elektronische Musik* developed in the NWDR studio in Cologne, where Karlheinz Stockhausen became the most prominent composer. While French and German electronic music history is well known and extensively studied, Tazelaar’s approach, rich and extremely well documented, gives us new insight into the way electronic music developed in the Low Countries and how the various actors contributed to the diffusion and dissemination of modern musical concepts.

Kees Tazelaar is a composer himself, and this probably gives him a view on sound and music that is unusual among researchers. He understands perfectly each concept, technique and tool, as well as the complexity of institutions, which always underlies human experience. He is capable of transmitting to the experienced or beginner reader the importance and complexity of this unique story in such a way that we feel part of it. He permits any reader to grasp the complexity of the technological environment before the age of computers, in a period when machines were electrical, electronic or mechanical. Today, technology is everywhere and seems simple to use; however, we often lack descriptions of how things came to be this way.

# Introduction



The emotional impulse that moves a composer to write his scores contains the same element of poetry that incites the scientist to his discoveries. There is solidarity between scientific development and the progress of music. Throwing new light on nature, science permits music to progress – or rather to grow and change with changing times – by revealing to our senses harmonies and sensations before unfelt. On the threshold of beauty science and art collaborate.<sup>1</sup>

Edgard Varèse, 1936

When I began teaching in the analog studio at the Institute of Sonology in 1993, I also took on the responsibility for its tape archive. The Sonology archive contains master tapes of electronic music dating from 1956 onwards, and it was high time to begin preserving, restoring and digitizing the oldest tapes in particular. My work on this task resulted in a number of CD productions; the box set *Popular Electronics*, made up of electronic music from Philips Research Laboratories and coproduced with the electronic music pioneer Dick Raaijmakers, is the most extensive so far. During my long and intensive collaboration with Raaijmakers, my interest in the historical aspects of electronic music production in the Netherlands grew. Raaijmakers also proved to be in possession of a large collection of documentation on the subject, which he wished to transfer gradually to me on account of his advancing age. This material was the starting point of the research on which this book is based.

From the outset, Dutch electronic music found itself in between two principal European trends: the *musique concrète* introduced by French radio in 1948 and the German *elektronische Musik* that emerged from 1951 onwards at the Cologne broadcast station. While the decisive step in *musique concrète* involved treating recorded sound as a given physical phenomenon and taking it as a starting point for experimentation and composition,<sup>2</sup> the purpose in *elektronische Musik* was to assemble sonic material from its most elementary components on the basis of compositional rules, with the help of tone generators, bringing sound into line with the organization of the other musical dimensions. In the Netherlands, there were initially no such unambiguous compositional-theoretical starting points. Although Dutch radio studios had been making electronic music on occasion since 1952, they did not yet have a purpose-built studio, as Germany and France did. The first real Dutch electronic music studio was built in 1956, not by a broadcasting company but, remarkably enough, by the acoustics department at Philips Research Laboratories.

Philips' corporate history has been extensively described in I. J. Blanken's five-volume *Geschiedenis van Philips Electronics N.V.* (History of Philips Electronics N.V.). However, Philips Research Laboratories' electronic music studio does not feature in it at all. This is not surprising, since electronic music at Philips was a byproduct of developments in the field of electroacoustics and played a marginal role in its corporate history. My research, however, reveals that Philips was of great significance for the genesis of Dutch electronic music. That genesis is the object of this study.

The book comprises three parts. The first describes the development of various aspects of electroacoustics at Philips Research Laboratories and the electronic music that arose as a result. The second part addresses the production and performance of electronic music for the Philips Pavilion at the 1958 World's Fair in Brussels. The final part deals with efforts made by organizations and composers, parallel to and after the electronic music-making at Philips, that led to permanent electronic music studios and related educational programs.

As a starting point I chose 1925, the year the engineer Roelof Vermeulen designed his first loudspeaker at Philips Research Laboratories. Its design marks the beginning of a period in which Philips expanded from a light bulb factory, began manufacturing radio tubes, and ultimately became a global force in electroacoustics. Although in fact no electronic music was produced at Philips between 1925 and 1955, many techniques developed during this period for loudspeaker technology, synthesized sound, reverberation research, recording equipment and spatial sound reproduction could be regarded as preludes to the birth of electronic music in the Netherlands. Vermeulen became the head of Philips Research Laboratories' acoustic department in 1947 and played a central role in the development of these techniques.

For Vermeulen, apart from accurately representing instruments' sound, another important requirement for reproducing music well was listeners' correct perception of the acoustic space in which those instruments were played. This applied not only to sound recordings but also to real-time "multiplication of concerts" that would enable many more listeners besides the audience at the live performance to enjoy a concert, not via a radio broadcast but in additional rooms where the music could be heard simultaneously with the live performance. After experiments at Philips, Vermeulen concluded in 1948 that this form of concert experience could be perfected to the point where it could even be preferable in some cases to attending the actual concert. At that point, listening to speakers without seeing musicians perform was not regarded as problematic. Later, though, it would regularly be cited as an objection to performances of taped electronic music in concert halls.

Roelof Vermeulen believed that besides serving Philips' business interests, his research program had a social function. With the emancipation of the working classes, traditional forms of musical performance would not be able to serve the increasingly large numbers of listeners, and electroacoustics could offer a solution. Moreover, according to Vermeulen, the working classes should be educated in music, so they would not fall prey to exclusively material desires, and electroacoustics could be deployed in this context. One of the electronic instruments used at Philips Research Laboratories in 1956 in the production of music, the electronic clavichord or Philichord, was part of an effort to develop inexpensive educational resources for domestic music-making.

This mixture of business interests and social motives also explains why the composer Henk Badings played an important role in Vermeulen's research program. Badings' traditionalist approach to the electronic medium and avowed distaste for modernism rendered him ideal for making music that presented a new sonic world but at the same time remained accessible for a general audience. The high esteem he enjoyed as a composer of symphonic music also

made him highly marketable for Philips. Vermeulen's unwavering support for Badings eventually turned the former's initially catalyzing role in Dutch electronic music into an inhibitory one, however, since Badings' musical ideas stood in diametrical opposition to developments that took place in the Dutch avant-garde.

In contrast to composers of *musique concrète* and *elektronische Musik*, Vermeulen allowed space for popular forms of electronic music. The first pieces produced at Philips, Dick Raaijmakers' "Song of the Second Moon" and "Night Train Blues," were presented to factory workers immediately after their creation via the internal radio station, the Philips Bedrijfs Omroep, or PhiBO. The arranger and bassist Tom Dissevelt continued experimenting with popular music in Vermeulen's studio in 1958 and 1959. Following the 2004 release of the *Popular Electronics* CD box set, some in the Dutch media asserted that musical genres like house and techno had their origins in the experiments in Eindhoven.<sup>3</sup>

Part 2 of this book is devoted to the electronic music made for the Philips Pavilion at the 1958 World's Fair in Brussels, the construction of which is described in detail in Marc Treib's book *Space Calculated in Seconds*. The pavilion is far and away Philips' most important contribution to worldwide electronic music history. Nevertheless, the plans for the Philips Pavilion evolved completely independently of the development of electronic music at the Research Laboratories. Furthermore, the music made for the pavilion had its own history, aims and key participants and is therefore treated as a self-contained subject in this book.

While Roelof Vermeulen's studio formed part of a research program in which even the production of popular music was intended as a scientific experiment with only scant public dissemination, the Philips Pavilion was intended as a large-scale demonstration of the professional equipment available from Philips' ELA (electroacoustics) division. The division was familiar with such demonstrations, having been in possession since 1948 of a well-equipped studio in Eindhoven in which amplifiers, microphones, recorders, loudspeaker systems, film projectors and reverberation units could be deployed. The Philips Pavilion can in fact be regarded as an on-site ELA demonstration studio. The fact that the demonstrations there eventually involved electronic music by the composers Edgard Varèse and Iannis Xenakis rather than recordings of traditional orchestral music was because the architect Le Corbusier, who had been commissioned to design the pavilion, insisted on working with Varèse.

From a compositional point of view, the music used in the ELA's popular World's Fair demonstration was ultimately much more experimental than that created at Vermeulen's Research Laboratories. In retrospect, one might think that Varèse, with his utopian ideas about spatial sound projection, would have been the ideal composer to assist in Vermeulen's research, but the latter unfortunately made no use of Varèse's seven-month presence in Eindhoven, nor was Vermeulen involved in the Philips Pavilion in any demonstrable way.

Around the same time as Philips was establishing the first Dutch studio for electronic music, Walter Maas, director of the Gaudeamus foundation for contemporary music, took steps that led to the founding of the Contactorgaan Elektronische Muziek (Electronic music contact organization), or CEM, and this is where Part 3 begins. Gaudeamus' important role in

Dutch contemporary music is well known;<sup>4</sup> CEM's has been less so. CEM's principal aim was to set up a studio where composers could be trained to make electronic music independently. Although the Philips studio was emphatically not meant for such a purpose, the corporation was represented in CEM by Roelof Vermeulen. A studio intended for composers' use opened in 1957 at the Technische Hogeschool (technical college) Delft.

In addition to establishing the studio, CEM rapidly began working in a more general sense to increase awareness of electronic music in the Netherlands. To this end, it was first necessary that the parties represented in CEM reach agreement as to the actual nature of electronic music; this involved the direct question of whether this was indeed the correct term, given that it seemed to refer more to German *elektronische Musik* than to French *musique concrète*. CEM did not wish to express a preference and thus considered other terms, such as "electro-*phonic music*," but eventually held to the term "electronic music," also for that in which sounds were recorded with a microphone and electronically processed.

Because today this term is more often understood as referring to electronic dance music than to music in the German tradition of Karlheinz Stockhausen and Gottfried Michael Koenig, and because the initial division between *elektronische Musik* and *musique concrète* based on theoretical principles has become obscured, the umbrella term "electroacoustic music" is often used. In this book, however, on historical grounds, I have chosen to use "electronic music" to refer to all music using electronic or electronically processed sounds.

In its early years, the CEM played an important role in staging electronic music concerts. However, by appointing the traditionalist Henk Badings and the modernist Ton de Leeuw as advisors, it condemned itself to numerous conflicts.

Vermeulen's retirement from Philips Research Laboratories in 1959 coincided with decisions to close not only the Philips studio in Eindhoven but also the studio at the Technische Hogeschool Delft. A power struggle around who would host a successor studio broke out between the universities of Amsterdam and Utrecht; the conservatories in Amsterdam and The Hague also became candidates, and CEM forcefully attempted to influence the course of events.

The work of the Philips studio eventually continued at a new studio at Utrecht University, STEM. But STEM was unable to take over the training duties of the Delft studio, so CEM set up a small educational studio in the town of Bilthoven as a stopgap. At the same time, plans for a new studio complex in Amsterdam were developed further. Thus, the aforementioned tension over which institution would take the lead in furthering electronic music was still not resolved. Dick Raaijmakers, originally meant to succeed Vermeulen as director of STEM, left the theater of conflict in 1961. Two years later, in emulation of Ton Bruynèl, he and Jan Boerman founded a private studio. Despite the highly restricted resources available to composers in these private studios in comparison with STEM, the compositions that came out of them were at least as important in artistic terms.

After Raaijmakers' departure, Henk Badings took over the direction of STEM in 1962. Subsequently, STEM fell into an almost total impasse. Meanwhile, Gottfried Michael Koenig was

establishing a successful internationally oriented electronic music course in Bilthoven. As a result of the quality of this course, Koenig entered the picture as a potential director of STEM. He took over the position in 1964. From then on, Koenig's course was gradually incorporated into the pedagogical program of STEM. With Koenig's appointment in Utrecht, the Badings era of Dutch electronic music came to an end.

At least as interesting as the Dutch arena within which Koenig eventually emerged as the appropriate person to breathe new life into STEM is Koenig's own history in the field of German electronic music prior to his activities in the Netherlands. That history is treated in detail for the first time in the present volume.

Koenig's need for electronic sound material arose around 1951, when he came up with compositional ideas that were hardly or not at all realizable using traditional instruments. His repeated attempts to gain access to the necessary technical resources ultimately resulted in Herbert Eimert inviting him to work in Nordwestdeutscher Rundfunk radio's Cologne electronic music studio in 1954. This marked the beginning of a fruitful period in which Koenig realized not only his own compositions but also many works by other prominent composers.

An initially very satisfactory collaboration with Stockhausen became increasingly problematic from the beginning of the 1960s. The two men's artistic insights gradually diverged, and as a result, their technical studio requirements became increasingly distant from one another. This became especially clear when a reorganization of the Cologne studio was announced. Crucially, Koenig anticipated the role computers would come to play in electronic music production. As early as 1963, he had taken a computer course at the University of Bonn and made his first experiments in musical programming. However, it rapidly became clear that Stockhausen had no interest in working with computers and that there would be no possibility of doing so in the Cologne studio in the foreseeable future.

As soon as he saw the possibility of becoming head of STEM, Koenig began investigating opportunities for using computers to make music in the Netherlands, and one arose at the Utrecht University computing center. Computer music would become an increasingly important subject in Koenig's educational program at STEM, which was renamed the Institute of Sonology in 1967 and gained access to its own computer in 1971, drawing worldwide attention.

The composer and conservatory director Kees van Baaren was part of CEM almost from the beginning, as a representative of the Dutch Composers' Association. His interest in electronic music increased from 1957 as a result of a number of his students working in the studio at the Technische Hogeschool Delft. When its closure became imminent, Van Baaren considered continuing its didactic activities at the Royal Conservatoire in The Hague, but his plan went no further. However, he picked up the thread again in 1965 after being approached by Raaijmakers. Van Baaren proposed that, instead of his students receiving private lessons at Boerman and Raaijmakers' private studio, a new electronic music studio be set up at the Royal Conservatoire. This studio, led by Raaijmakers, came into being at the end of 1966 and had a major impact on the composition department of the Royal Conservatoire.



A number of subjects cut across the tripartite structure of this book; two are spatial sound projection and the use of electronic music in film.

The spatial projection of sound is not only dealt with in the part on Vermeulen and his activities in Philips Research Laboratories' acoustics department; a perceptible line stretches from Vermeulen's first mono loudspeaker via the arduous conquest of stereophony to "ambiophony," culminating in the part on the Philips Pavilion. Concepts of spatiality reappear in Part 3 in connection with experimental theater and in focusing on the critical positions on the subject Koenig took in his first lectures in the Netherlands. Partly inspired by Stockhausen, Raaijmakers finally began integrating the spatial reproduction of sound in a compositional concept in 1963.

Although the Philips radios of the 1920s and 1930s achieved a high sound quality for the time, their monaural nature remained a serious limitation. Philips's position was that the reproduction of sound through a single loudspeaker offered the listener no more than a virtual hole in the wall of the space in which the music was performed. While the introduction of stereophony delivered improvements, making the locations of instruments in space perceptible and their diverse sound colors better distinguishable, for Vermeulen, something essential was still missing: the experience of the space itself. Experiments with binaural recording using artificial-head microphones and with stereophonic recording were therefore soon followed by forays into "ambiophony," in which loudspeakers reproducing stereo sound were supplemented by indirectly oriented speakers to create a "diffuse" sound. Vermeulen wished to reproduce sound in such a way that it would manifest itself naturally throughout the space around the listener. He shared this desire with the American conductor Leopold Stokowski, with whom Philips collaborated between 1946 and 1948.

The desire to accurately record and reproduce the acoustic properties of a musical performance space led to a new ambition to use electroacoustic means to influence those properties. Stereo reverberation devices developed in the 1950s for this purpose by Vermeulen were in use in numerous theaters and concert halls, such as the Teatro alla Scala in Milan, and found further application in the production and performance of electronic music. To make possible an "ambiophonic" performance, the first electronic composition realized at Philips – Henk Badings' ballet *Kain en Abel* – comprised two tracks, one projected directly through on-stage loudspeakers and the other diffusely through speakers surrounding the audience.

The audio technology used in the Philips Pavilion at the 1958 World's Fair took things a step further. The electronic music made for the pavilion was reproduced via more than three hundred loudspeakers distributed across its walls. While electronic reverberation was now used for sound effects integrated within the taped music, the sounds could be moved between speakers along various "sound routes" during performances. Such an advanced installation for the spatial projection of electronic music was unheard of at the time, and it continues to speak to the imaginations of the current generation of electronic music composers.

At the time of the Philips experiments, interest in spatialization was not limited to music. Toneelwerkgroep Test (Test theater study group), established in 1956, attempted to spatialize

theater by placing the audience around the actors and experimenting with electronic music. In a 1962 letter, the founders of the Mood Engineering Society, the predecessor of the Dutch branch of the Fluxus movement, called on local authorities to provide a new theater in which all fixed elements – stage, seats, balconies, orchestra pit – would be replaced by mobile installations and the acoustics would be variable, so that the space could adapt to the demands of a work rather than the other way around.

The aforementioned ideas about spatiality focused principally on the performative aspects of music and theater. From 1963 onwards, problems connected with the way sound travels through space motivated Raaijmakers to completely reorient his attitude towards composing electronic music. In his view, the electronic or electronically processed sounds on the tape should no longer be the sole subject matter of composition: the way those sounds manifested themselves in space after they left the speakers should also be composed.

Electronic music for film is also a common thread running through this book. Nowadays, the radiophonic work *Weekend* (1930) by the German film pioneer Walter Ruttmann (1887–1941) is regarded as a *musique concrète* composition *avant la lettre*.<sup>5</sup> In the Netherlands, Lou Lichtveld's music for Joris Ivens' 1931 film *Philips Radio* stands as an early example of the compositional application of experimental sound recordings and montage techniques. Ivens made this film about the production of Philips radios immediately after the introduction of sound in film, under the influence of Russian social realism; the industrial noises matching the images were not recorded during shooting but subsequently simulated in a French sound studio using various devices and objects.

More than twenty years later, Ivens and Lichtveld's experiment saw a sequel in the form of the electronic music for Han van Gelder's space-travel movie *The Conquered Planet*. Van Gelder used newly purchased Philips equipment at Toonder Studios; the electronic music studio at Philips Research Laboratories had not yet been established. *The Conquered Planet* was neither made nor commissioned by Philips but was subsequently purchased by the company and used to advertise its telecommunications equipment. Between 1953 and 1965, electronic music was composed by various composers for at least 23 Dutch films, many animated and most commissioned by Philips. Electronic sounds – sometimes in contrast to instrumental music – proved eminently suited to illustrate film scenes depicting industrialization, mechanization, alienation, futurism and space travel.

With the end of Philips' influence on Dutch electronic music, new dimensions became visible. Well-appointed studios and educational programs arose around 1965, and composers were able to gain access to these facilities. An extensive cultural focus on electronic music came about as a result. This book's title, *On the Threshold of Beauty*, alludes to this new situation.

**Part I**

**Electroacoustics**

**and**

**Electronic**

**Music**

**at**

**Philips**

**Research**

**Laboratories**

# Chapter 1

## Developments in Electroacoustics at Philips before 1945

### Philips Research Laboratories

In January 1914, the physicist Gilles Holst (1886–1968) began working for the Philips company. It was the starting point of systematic scientific research at the Philips Natuurkundig Laboratorium (literally, the Philips Physics Laboratory; referred to henceforth as Philips Research Laboratories). Holst remained in charge of the laboratories until 1946. During this period, they were an integrated part of the company and played an important role in the diversification of its product range.<sup>1</sup> Holst was a physicist with wide-ranging interests and a remarkable general education. It was people like himself whom he preferred to see working at Philips. In general, he did not look for people who specialized in areas relevant to specific products. The benefit of this policy was that problems could be looked at from many different angles. Holst did not usually give precisely defined assignments to his employees. He tried to stimulate enthusiasm for the things that he was interested in himself. According to Holst, you could not expect original results from someone who wasn't convinced that the given assignment made sense. He was not in favor of a strictly hierarchical structure. The downside of an organization which was too rigid was that it could not take into account the individual qualities of the researchers, the most original of whom often had difficulties in adjusting to such an organization.

Holst had managed to obtain a position for the Research Laboratories which was highly independent from Philips' main industrial groups. These groups could express their wishes, of course, but it was Holst and his staff who decided what the research program would be. Holst fought hard for that independence. This made it much easier for his successors, because by the time they came along, upper management was already convinced that an independent research laboratory was the most fruitful solution for a company with such a diverse product range.<sup>2</sup>



*Fig. 1.1: Philips Research Laboratories in 1929, during the third construction phase.*

By the time Holst retired in 1946, the diversity of research topics was such that he proposed to the Philips board of governors that command of the laboratories be handed over to three new directors, each of whom would become responsible for a wide field of research. Hendrik Casimir (1909–2000) would lead physics research, Evert Verwey (1905–1981) would lead chemical research, and Herre Rinia (1905–1985) would lead the groups occupied with machines and systems.<sup>3</sup> By now, the laboratories were functioning as an autonomous entity among Philips' independent product divisions, each of which also had its own development lab. Towards 1958, around the time of the existence of the electronic music studio at the research laboratories and the Philips Pavilion project for the World's Fair in Brussels, the company had 58,000 employees in the Netherlands and 153,000 worldwide.<sup>4</sup>

## Radios and Loudspeaker Development

During a stay in Paris in the summer of 1923, Anton Frederik Philips (1874–1951), the director of Philips, saw the appealing neon advertising signs made by the French company Paz & Silva. That year, after Philips obtained a license from the patent holder, George Claude (1900–1955), Philips Research Laboratories recruited Roelof Vermeulen (1897–1970), who had earned degrees in mechanical and electrical engineering at Technische Hogeschool Delft, to make these so-called "Claude tubes." Development of the tubes began in March 1924.<sup>5</sup>

On October 21, 1925, Vermeulen applied for a patent which would form the basis of his further career. It described a "device for the conversion of electrical into mechanical vibrations" – a loudspeaker – and was granted on April 24, 1928.

The manufacture of electron tubes at Philips had greatly expanded and had been integrated with the making of light bulbs. By the end of the 1920s, the company's activities included all areas of the radio industry, with the exception of the broadcast of actual programs. The mass fabrication of radio devices, which began in 1927, marked the beginning of a period of almost uncontrolled expansion which fundamentally changed not only the company's size but in many aspects also its nature. Philips had started as a light bulb factory, but the development of loudspeakers took the company into an area that went far beyond radio: that of acoustics. The development of the first radios at Philips Research Laboratories started in September 1926. A year later, the first commercial radio set incorporating Vermeulen's loudspeaker design was exhibited at the annual trade fair in Utrecht.<sup>6</sup> Louis Kalf (1897–1976) produced the industrial designs for the receiver and the loudspeaker.<sup>7</sup>

By May 1928, Philips was making 1,500 radio receivers a week, and by 1929 that figure had risen to 2,500. The introduction of radios had succeeded far beyond the expectations of the company's board of directors.<sup>8</sup>

In the meantime, Holst, the physicist Arend Thomas van Urk (1891–1977) and Vermeulen had applied for another patent on February 18, 1927. It described a loudspeaker design based



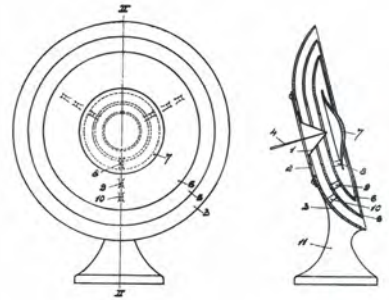
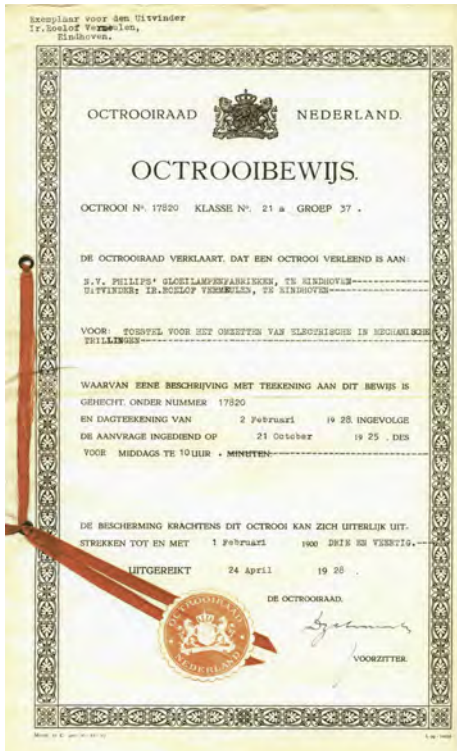

Fig. 1.2, 1.3 and 1.4: The patent, the attached diagram and the final product.

on the use of a moving coil and a permanent magnet, unusual at the time.<sup>9</sup> A later patent (applied for on November 13, 1928) proposed the use of permanent magnets as a system for the conversion of electrical energy into mechanical and vice versa. The patent described how the technique could be used in telephones, microphones, loudspeakers and measuring apparatuses.<sup>10</sup>

By 1939, the acoustics department of Philips Research Laboratories developed a fully automated procedure for loudspeaker measurement. Loudspeakers could be placed in an anechoic chamber or outside on the roof of the building and test tones played back from them and picked up by a microphone.

In the loudspeakers of the time, the upper limit of the reproduced spectrum was around



Fig. 1.5: Philips' first radio receiver, the 2501, with the 2007 loudspeaker.

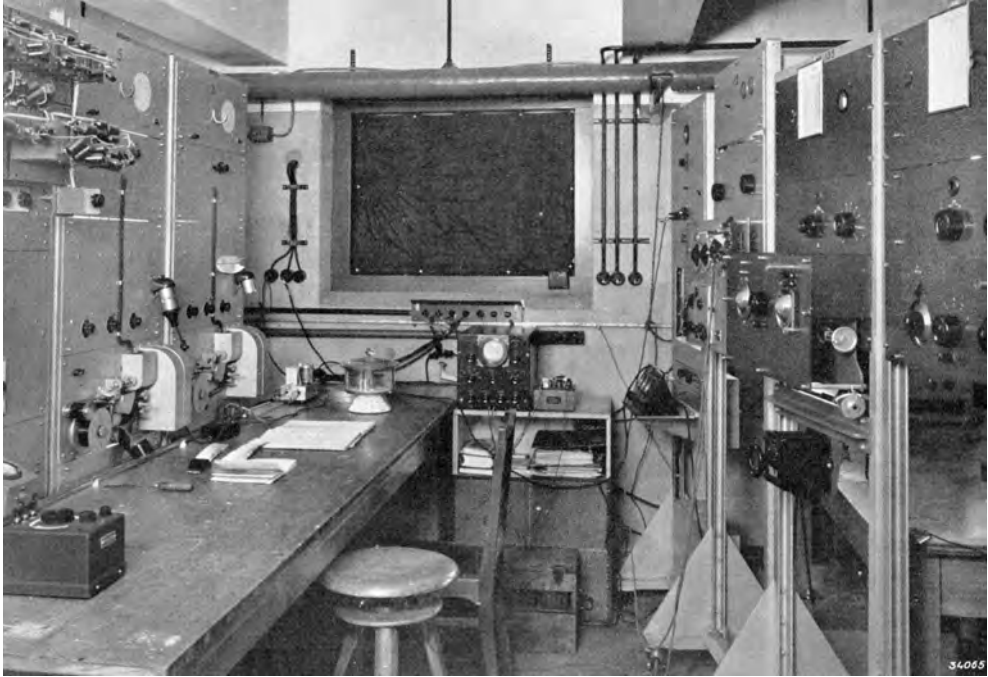

*Fig. 1.6: The complete installation for the automated registration of frequency characteristics. At left is the registration apparatus; at right are two tone generators and the amplifier. On the wall, on either side of the window, is a series of sockets and connection clips leading to various rooms and the roof, where loudspeakers could be positioned to be measured.*



*Fig. 1.7 and 1.8: At left, the anechoic chamber with a loudspeaker at the rear (mounted in a panel) and a microphone in front of it. At right, the roof of the acoustics department, with equipment for loudspeaker measurement.*

8,000 to 9,000 Hz, ensuring at least that the inevitable suppression of the higher frequencies in radio and phonograph sound would not be added to by the loudspeaker itself. The frequency range of receivers for AM (amplitude modulation) broadcasts had traditionally been cut off at 4,500 Hz to avoid interference by transmissions on neighboring carrier waves. But in the 1930s, the FM (frequency modulation) broadcasting technique was gradually introduced in the United States, allowing for reproduction of a much wider frequency range. Commercial FM stations were licensed from 1941, and by the end of that year, production of FM receivers was running at an estimated 1,500 a day.<sup>11</sup> After World War II, Belgium, the Netherlands, Denmark, and in particular Germany were among the first European countries to adopt FM on a widespread scale. The new Philips receivers therefore had to be able to reproduce the wider frequency range of FM broadcasting. Another reason for the development of better loudspeakers was that new materials for making phonograph records had reduced their playback noise and made it possible to play back higher frequencies. Furthermore, the introduction of magnetic recording techniques would soon set new standards for an even wider range of the sound spectrum.

In light of these improvements, it became desirable to raise the loudspeaker's upper limit to about 16,000 to 18,000 Hz. Philips found a solution in building a loudspeaker with two cones instead of one, with a small cone for higher frequencies positioned in front of the larger one and connected to it.<sup>12</sup> The Philips 9710M loudspeaker of 1954 was a tremendous success and stayed in production for at least 25 years.<sup>13</sup> It found its way into many applications, including the loudspeaker system in the Philips Pavilion at the 1958 Brussels World's Fair.

Philips' loudspeaker development had brought the company into the arena of acoustics by 1928. Acoustic measurement became necessary for supporting Philips Research Laboratories' loudspeaker research, so microphones had to be further developed as well. Gradually, the company also became involved in sound reproduction and the acoustic qualities of auditoriums and concert halls. Another related field of research was that of sound perception, later investigated by people including the physicist Jan Frederik Schouten (1910–1980).<sup>14</sup> Of particular importance for electronic music was the fact that Schouten went on to develop a device for the synthetic production of sound (see Chapter 1, 33–5).

Through radio, Philips also became involved in sound recording techniques. For Vermeulen, a scientist and a musician, the acoustics department at Philips Research Laboratories was the perfect environment. It allowed him to develop many of his ideas involving electroacoustics and music. In 1945, Vermeulen stated that embedded in the company's vision of

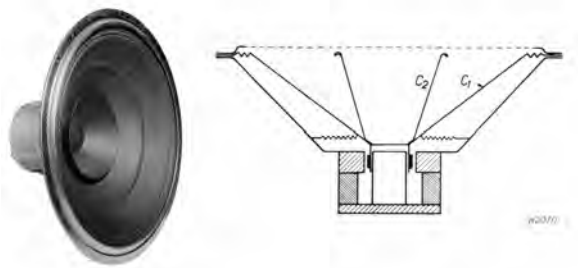

*Fig. 1.9 and 1.10: Philips 9710M double-cone loudspeaker. C<sub>1</sub> is the cone for lower frequencies, C<sub>2</sub> that for higher ones.*

the future of music was the fact that Philips considered radio receivers, phonographs and sound film projectors to be musical instruments.<sup>15</sup>

## Film Sound: The Loetafoon and the Film *Philips Radio*

In March 1928, Philips decided to substantially expand its Research Laboratories. The company considered it necessary to anticipate developments in the electronics field, such as television, sound film and the electric phonograph.<sup>16</sup> The laboratories' acoustics division obtained its own cinema for the testing and demonstration of sound film equipment.



Fig. 1.11: Testing Vermeulen's improved Loetafoon at Philips Research Laboratories.

Initially, the principle of the electric phonograph, developed in 1925 by Western Electric, was used in equipment for playback of film sound. Western Electric managed to convince the Warner Bros. movie studio to experiment with its new technique and record a number of sound films, which resulted in the founding of the Vitaphone Corporation. By the end of 1926, Vitaphone had installed almost hundred "talking picture" systems in the United States.<sup>17</sup> The Vitaphone system combined moving pictures with sound recorded on phonograph discs, with synchronization between the two achieved mechanically. The records used had a diameter of 40 centimeters, enough to provide a standard 300-meter film reel with sound.<sup>18</sup> However, mechanically connecting the two different information carriers caused numerous problems. And although the optical recording of sound as an additional track on the film strip itself<sup>19</sup> would soon replace the Vitaphone system, this could not be foreseen in 1928. For the moment, all

the major movie studios had decided to use the Vitaphone technique.

In the Netherlands, the first complete sound film premiered on March 15, 1929, at the Apollo cinema in The Hague. The American movie *Two Lovers* had originally been made as a silent film. Although the studio had added music and sound effects later, there was still no dialogue; therefore, the film had over 170 title shots.<sup>20</sup> This event was soon followed by the premiere of another sound film at Cinema Royal in Amsterdam on April 11.<sup>21</sup> Both premieres

were promoted by Loet Cohen Barnstijn (1880–1953), who ran a film distribution company and a trading company called Loetafoon N.V. that specialized in selling and renting machines for sound reproduction and talking films. Loetafoon N.V. marketed a system based on the Vitaphone principle. Barnstijn sought collaboration with Philips for the electroacoustics, and Philips eventually took over all shares in Loetafoon N.V. Philips Research Laboratories were quite positive about the company's entry into this field, considering it necessary to stay involved in the development of talking films because of their common ground with the wider field of electroacoustics.<sup>22</sup>

In November 1929, Loetafoon N.V. expanded its system to incorporate optical sound film technology. From then on, the Loetafoon was available as either a phonograph system, an optical system or – preferably – one that combined the two techniques. A complete Loetafoon system consisted of an optical sound unit, a phonograph unit and a motor, each on free-standing pillars that could be positioned around the projector.

During 1930, Philips set up its own production line for synchronized phonographs and optical sound heads. The new Philips devices were developed under Vermeulen's supervision, with the possibility of export in mind. Vermeulen managed to improve the technical aspects of the Loetafoon, although in essence the system had remained the same. The phonograph still occupied a central position, which was the disadvantage of the system as a whole.<sup>23</sup>

In 1930, Vermeulen published an article giving a brief overview of the principles of sound film and discussing two necessary conditions: the exact synchronization of sound and picture and a rigorously constant speed of the sound record. He extensively described a series of techniques for improving these two aspects. In the first section, he arrived at some interesting conclusions on the perception of time differences between image and sound. One was that, although it was not possible to detect a time difference between image and sound of less than 1/10 of a second, such a difference was enough to disturb the illusion that the sound was being produced by the image itself. Instead, one would get the impression that its source was located somewhere else. This, he continued, was presumably based on the fact that people were used to hearing the sound of a source whose distance they estimated optically somewhat later in time. It appeared to him that, in this respect, the ear was sensitive enough to find such small time differences annoying. However, with proper synchronization, something remarkable would occur: one would be much more free to choose where to position the loudspeaker. The suggestion that the image was actually producing the sound would be so strong that it would dominate perception of the sound's localization.<sup>24</sup> Later in the article, Vermeulen raised the important unanswered question of whether optical sound recording would develop to the point of being able to fully push aside the phonograph technique. In the third section, he described the main improvement made over the original Loetafoon: replacing the mechanical synchronization of sounds and images with an electrical system. The technology could be described as an "electrical shaft,"<sup>25</sup> similar to that which would later synchronize the audio and projection equipment used for *Le poème électronique* at the 1958 Philips Pavilion. The



article concluded by stressing the importance of the practical experience gained in the new film room at Philips Research Laboratories, built especially for this purpose. The special room, with acoustic characteristics equal to those of a cinema full of people, would also be indispensable for the further development of phonographs, amplifiers and loudspeakers, for which talking films created great demand.

The Loetafoon brand name disappeared in 1931. The equipment continued to be sold under the Philips brand, mainly for export. Philips sold only fifteen installations in the Netherlands in 1931 and 1932 but almost five hundred abroad. In 1933, Philips marketed its own projector, the Philisonor. After that, international film equipment sales were handled by Philips' Cinesonor N.V., the successor to Loetafoon N.V.<sup>26</sup>

Sies W. Numann<sup>27</sup> (1905–1981), chief of public relations at Philips and later its head of general advertising, had commissioned the director Joris Ivens (1898–1989) to make a promotional film for the company in 1930.<sup>28</sup> Ivens, a confirmed communist, had just returned enthusiastically from a long journey through the Soviet Union. The commercially oriented Numann's choice might seem strange, but Numann was a member of the Dutch Filmliga (film league), of which Ivens was a cofounder. The Filmliga (1927–1933) tried to create interest in the Netherlands in European avant-garde films and movies from the Soviet Union, which, especially in those years, took a particularly artistic view of industrialization. This presumably explains Numann's interest in Ivens.



Fig. 1.12: Recording the sound of striking an empty gas cylinder. From left: Mark Kolthoff, Joris Ivens, the German sound engineer Kretsch and the French sound mixer Georges Leblond.

The film *Philips-Radio* (also known as *Symphonie Industrielle*) was shot mostly in Philips' factory halls and Research Laboratories in Eindhoven and showed the various stages of the modern production process of Philips radios and related subjects. These included the manufacture of light bulbs and valve tubes for the reception and transmission of radio waves, a broadcasting station, equipment for high-voltage experiments, assembly line workers, and

trucks and trains being loaded with finished products. Of particular interest is a sequence showing a test procedure designed to measure the total sound radiation of the Vermeulen/Kalff loudspeaker. The test took place in a “hard chamber,”<sup>29</sup> with the loudspeaker mounted on a spinning table and the microphone rapidly moving around it in a wide circle to avoid standing waves.<sup>30</sup> *Philips-Radio* was the first Dutch sound film. The music was composed by Lou Lichtveld (1903–1996),<sup>31</sup> who also created the sound effects. To record the sound, Ivens and Lichtveld went to the Films Sonores Tobis studio in an old monastery in Épinay-sur-Seine, near Paris. They recorded the sounds of a grindstone, a windlass, an oxygen cylinder and many other objects. While the musical parts of the soundtrack were somewhat conventional, the use of recorded machine sounds was strikingly modern. Particularly in the opening scene (0’20”–1’30”), which features a rapid succession of “concrete” sounds and very short musical phrases, the speed of the montage dominates the sound material to such an extent that, in retrospect, this part of the *Philips-Radio* soundtrack can almost be categorized as “electro-acoustic.”

Vermeulen traveled to Paris from May 18 to 21 to personally witness the sound recordings at Films Sonores Tobis. In an account of his trip, he described how the men cut the film into small fragments so that each part of the soundtrack could be recorded separately.

The recordings were supervised by the sound engineer Kretsch and the sound mixer Leblanc. The sounds that needed to be recorded were selected, and then experiments were made to find out which sources were needed to simulate these sounds in an optimal way. Then the scenes were projected and the sounds were recorded in real time. Siemens ribbon microphones were used to everyone’s satisfaction. They were robust and needed little maintenance. Each microphone had its own amplifier in a central amplification room. The signals were combined in a mixing room, where nine potentiometers and a master control were available to make the necessary level adjustments. From there, the sound was sent to separate amplifiers from every recording device and the monitoring loudspeaker. The sound was recorded onto film as an optical sound track with the so-called Kerr cell technique. The studio had disposal of a synchronous generator with a frequency of 48 Hz, so that the recording machines could be synchronized electronically with the cameras and projectors.<sup>32</sup>

After the premiere of *Philips-Radio* on September 28, 1931, Ivens and Lichtveld were decorated with huge laurel wreaths by a Philips engineer on the stage of the Theater Tuschinski in Amsterdam.<sup>33</sup> Nevertheless, the film mainly received criticism. Most reviewers considered it too much of an ode to the machine.<sup>34</sup> They repeatedly wrote that Ivens showed excessive interest in the machinery and little to none in the people who operated it. The film was even called an “inhuman document.”<sup>35</sup>

## The Philips-Miller Recording System

The Philips-Miller recorder was a result of a collaboration between Philips and the American engineer James Arthur Miller of the Miller Broadcasting Company, founded in 1932. Miller had invented a method for mechanically recording sound on film.<sup>36</sup> His Philimil film consisted of celluloid with a thin layer of transparent gelatin applied to it. This so-called cutting layer was covered with an extremely thin, opaque top layer. Through the use of an electrically driven V-shaped sapphire chisel that moved up and down, sound vibrations could be recorded in the form of a transparent track on the film, which was transported under the chisel at a constant speed.<sup>37</sup>

The reading of the track during playback was identical to the reading of an optical soundtrack in a cinema projector. The frequency range was 50 Hz to 7,000 Hz within 2.5 dB and 30 Hz to 8,000 Hz within 6 dB, considerably better than that of radio receivers and phonograph records at the time. Another big advantage the system had over direct-to-disc recording techniques was that one could edit a Philips-Miller film by splicing, so mistakes in a performance could be corrected through replacing them with different takes. Each Philips-Miller recording system consisted of two recording/playback units. Just before the tape on one recorder reached its end, the second unit would automatically take over the recording, and so on, making it possible to seamlessly record very long sessions. According to Holst, the system's most obvious advantage was that photographic processes, such as developing and

printing, were not necessary. Recordings did not have to be made in the dark, and the results could be verified immediately. It would not, however, be until 1934 that the further development of the Philips-Miller system was given priority.

At the official introduction of the system in 1936, the commercial department aimed primarily at renting and selling the recording and playback machines to broadcasting companies. The system was demonstrated in Paris at the annual conference of the Union Internationale de Radiodiffusion, the international broadcasting union, on February 27 of that year. According to a correspondent for the *Nieuwe Rotterdamsche Courant*, the guests could be assured that the quality of the recorded performance had been on the same level as the live transmission. During the presentation, a recording made in Eindhoven of the Concertgebouw Orchestra conducted by

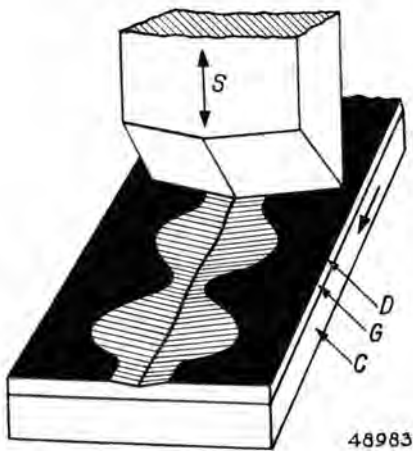
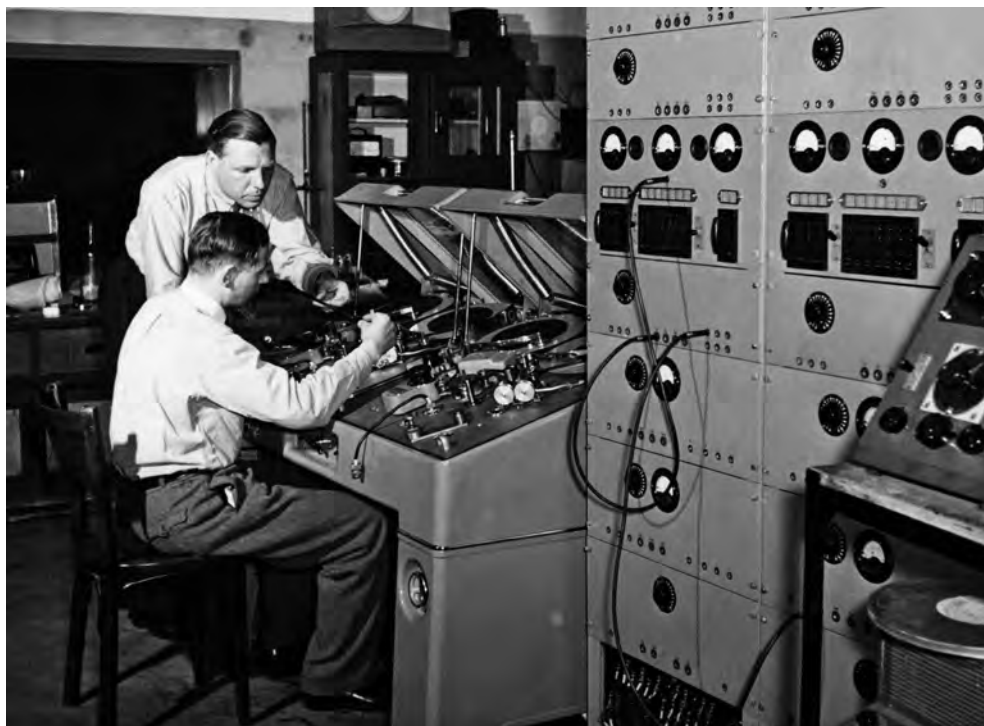

Fig. 1.13: Principle of sound recording used in the Philips-Miller System. Philimil film consisted of a celluloid carrier (C) with a gelatin layer (G) and a very thin opaque top layer (D). The chisel (S) vibrated perpendicular to the film, which moved in the direction of the arrow, and cut into it; thus was a transparent soundtrack produced.



*Fig. 1.14: The Philips-Miller recording system at Philips Research Laboratories.*

Willem Mengelberg (1871–1951) had clearly shown the advantages of the system.<sup>38</sup> Some months later, the BBC was the first broadcasting company to order the Philips-Miller machines. In the years that followed, more and more broadcasters showed interest. In the fall of 1938, the Nederlandse Christelijke Radio Vereniging (Dutch Christian broadcasting company) (NCRV) was the first in the Netherlands to install a Philips-Miller system. However, for most companies, the system's advantages could not compensate for the high price of its installation and operation. In the area of film sound, no commercial success was achieved whatsoever.<sup>39</sup>

A mobile Philips-Miller system built into a recording van was described in an article in the *Philips Technical Review* in 1939.<sup>40</sup> The Philips-Miller technology was appropriate for mobile recordings because of its insensitivity to shocks caused by driving on bumpy ground, the slamming of car doors, the entry of technicians, and so on. One of the recording decks was equipped with an electrical splicing unit, so programs could be edited on location.



*Fig. 1.15: Mobile recording van with a Philips-Miller system.*



Fig. 1.16: Detailed view of the recording deck with a splicing unit.

In the United Kingdom, the outbreak of war increased the need for recording facilities. The risk of air raids after dark had made it prudent to pre-record programs during daylight hours. The BBC commissioned another six Philips-Miller recording devices before the invasion of the Low Countries cut off further supplies of the machines and of Philimil film, which was made in Belgium.<sup>41</sup>

After World War II, Philips Research further improved the Philips-Miller system, increasing both the frequency range and the dynamic range of the recordings. It had also become possible to record in stereo. But soon after the introduction of magnetic recording technology, the Philips-Miller system disappeared.<sup>42</sup> The BBC took its last machines out of service in 1952–1953.<sup>43</sup>

## Stereophonic Sound

The development of stereophony would prove to have great advantages for the faithful recording and reproduction of music. Yet the first article in *Philips Technical Review* on stereophonic “artificial head” microphones did not discuss them in a musical context. The 1939 article contained a description of an installation developed for the study of the necessity of directional hearing in hearing aids for people with partial deafness.<sup>44</sup> Although the research related to hearing aids, the technology was still far from portable, since the use of high-quality microphones implied the use of relatively large amplifiers as well.

The authors stated that without binaural information, the ability to focus on a particular sound source was lost in situations where many sources were simultaneously present. They also cited this as a reason for the fact that in broadcasting studios, the amount of reverberation needed to be smaller than under normal circumstances.<sup>45</sup> They pointed out that during audio reproduction, sounds that had originally reached the microphone from all directions in the studio were received by the listener from just one direction, that of the opening of the loudspeaker. The use of two microphones and two speakers should allow for the preservation of directional information. To ensure that differences in intensity and timing would be identical to those detected by human ears, the microphones were mounted on an artificial head. An approximation of the human head, which had more or less the same dimensions, was considered sufficient.

However, not all properties of directional hearing could be explained in terms of differences in intensity and timing. For instance, these differences could be the same for a sound source

in front of the listener and one behind him, yet with his eyes closed, he could distinguish between the two. It was considered possible that small details of the shape of the head might play a role. Listening tests were done with a more detailed artificial head, but this made no difference. It was thus concluded that small movements of the head were essential in distinguishing sounds that were either in front or behind the listener.

An April 1940 article again argued for the necessity of stereophonic sound reproduction in radio and cinema on the basis of an extensive explanation of the phenomenon of directional hearing. It also mentioned the role of reverberation in the perception of the distance of a sound. The article introduced the artificial head technique as a means of reproducing a stereophonic sound image through loudspeakers in an auditorium. Despite the fact that, according to the theory, every listener in the auditorium should in fact be wearing headphones, a sufficient stereophonic effect was obtained with loudspeakers during tests. For stereophonic sound reproduction in cinemas, the article proposed the use of two speakers for higher frequencies placed at either side of the screen and one speaker for fre-



*Fig. 1.17: The artificial head was placed on the table. The two amplifiers were set up under the table. The man with the headphones was able to follow the conversation in stereo.*

quency reproduction in cinemas, the article proposed the use of two speakers for higher frequencies placed at either side of the screen and one speaker for fre-



*Fig. 1.18 and 1.19: Artificial heads with microphones: at left, a spherical approximation of a real head; at right, a more realistic model.*





Fig. 1.20: 1950s living room with a loudspeaker for low frequencies in the corner and satellite speakers on the table by the window and on the shelf (see arrows).

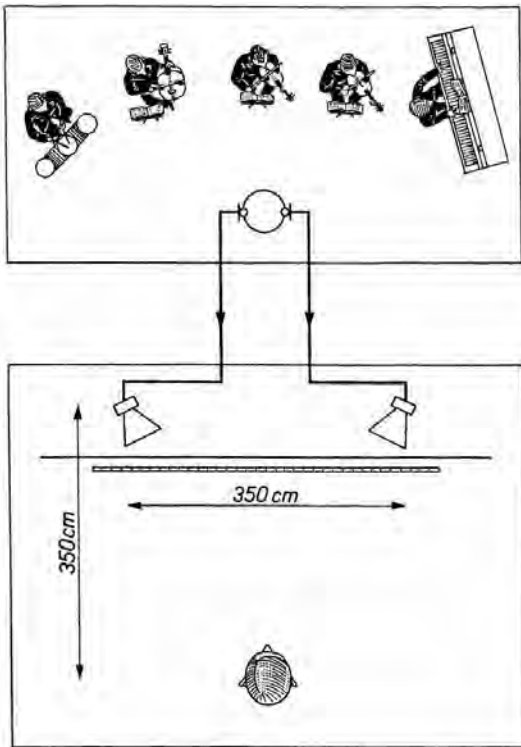

Fig. 1.21: Diagram of a stereophonic sound transmission using an artificial head. The listener was able to locate the sound sources on the measuring rod in front of him to an accuracy of a few centimeters.<sup>47</sup>

quencies below 300 Hz positioned in an arbitrary place – for instance, behind the projection screen – since lower frequencies do not contain directional information. The concept of separate low and high frequency reproduction would later be used in speaker systems for 1950s living room and – more importantly in this context – in the 1958 Philips Pavilion.

Another article published just two months later<sup>46</sup> described tests conducted with stereophonic phonograph records. Stereophonic sound reproduction was briefly explained again, with the addition of fig. 1.21.

The illustrated situation still did not address one possibility: that of making stereophonic recordings. Since such recordings were considered necessary for further experiments as well as for the practical use of the described technique, tests were conducted with stereophonic sound on phonograph records. To make this possible, the disc's surface was divided into two zones.

During recording, the two cutting needles moved along the same straight line (see fig. 1.22). But if two identical pickup arms were used during playback, the trajectories of the needles were slightly different because the turning points of those pickup arms were different. This would cause very small time differences between the left and right channels – great enough, however, to disturb the stereo image. The problem was solved by using pickup arms of different lengths (see fig. 1.23).

Almost a year later, in March 1941, the scientist Kornelis de Boer described the experimental use of two Philips-Miller recorders for stereophonic recording and reproduction in

another article for *Philips Technical Review*.<sup>48</sup> The two units of one system, which would record or play back alternately during normal operation, were here used simultaneously to record both the left and right channels of the stereophonic signal onto one Philimil film that was running through the two units.

However, the method described had various technical problems that were difficult to solve.<sup>49</sup> Also, recordings made in this way would not have been compatible with standard monophonic playback equipment. Such equipment played back the left and right channels simultaneously, whereas here the two were recorded approximately one meter apart. In addition, the possibility of splicing the tape, one of the system's main advantages, would be lost. De Boer therefore proposed another method for stereophonic recording on Philips-Miller tape: affixing a second chisel to a single recorder opposite the first chisel, so that the two tracks would be cut into the film at the same physical position. Although he wrote that the second method had been successfully tested, at the time, it remained an experimental addition to the equipment.

The stereophonic Philips-Miller system was a state-of-the-art recording technique for studios, but special units were also designed – though never commercially produced – for playing back cellophane copies of recordings at home. Cellophane prints made on Philimil film could be produced efficiently using existing photographic techniques. The precise definition of the mechanically recorded originals and the high resolution of the photographic copying material meant exceptional sound quality could be obtained



*Fig. 1.22: Apparatus designed for stereophonic sound recording on phonograph discs. Each of two chisels was fed signals from one of the microphones on the artificial head. The chisels cut two separate tracks: one in the record's inner zone and one in its outer zone.*



*Fig. 1.23: Playback of a stereo recording on a phonograph record with two pickup arms of different lengths to compensate for timing differences between the left and right channels.*

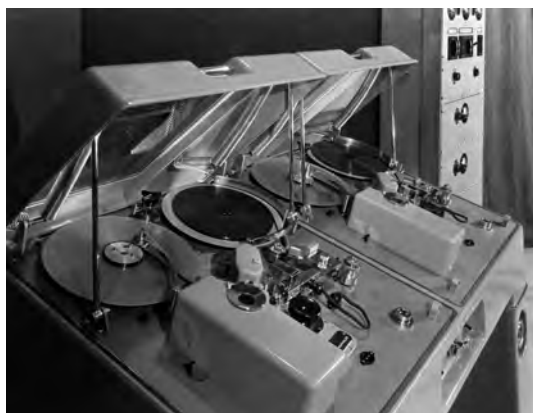

*Fig. 1.24: The two units of a Philips-Miller system.*



with respect to high frequencies and absence of nonlinear distortion. The combination of high reproduction quality and the increased realism of stereophony were seen as conditions that would restore the original musical character to “mechanical music.” The low cost of the reproduction method meant such ideal music reproduction could be enjoyed at home. Another advantage of cellophane tape was that a reel with a diameter of just eighteen cm could hold up to an hour of music.<sup>50</sup>

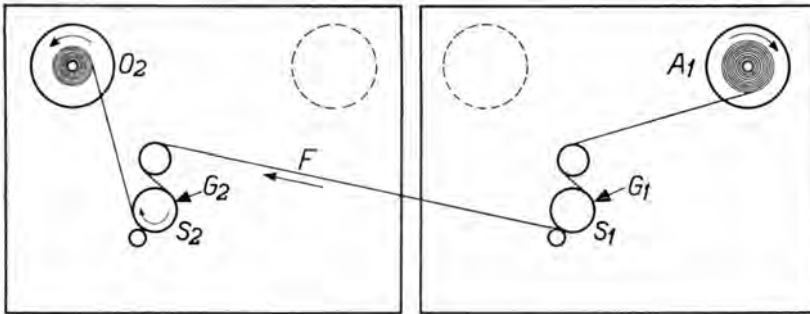

Fig. 1.25: Stereophonic audio recording on one Philimil film running over the two units of one Philips-Miller system.

During the first year of the German occupation of the Netherlands, research at Philips' laboratories continued more or less in a normal manner. In the years that followed, although activities did not come to a complete halt, the number of scientific publications and colloquia seriously declined.<sup>51</sup> *Philips Technical Review* was not published from October 1942 until late 1945.<sup>52</sup> But by the second postwar issue, De Boer was again stressing the importance of stereophony.<sup>53</sup> This time, he emphasized the benefits of stereophonic sound reinforcement in concert halls, theaters and cinemas. He explained that stereophonic reproduction in a cinema would cause the sound to be heard as coming from the same direction as its visible source on screen. But when sound reproduction was applied *without* the listeners being able to see the original sources, a considerable improvement in quality could be achieved through the application of stereophony as well. The artificial head microphone technique had therefore been further developed, with two additional electronic controls introduced by De Boer to transform the stereophonic image: a “wide-narrow” controller and a “left-right” controller. In the last section of the article, he explained how two individual microphones could be used instead of the ones attached to the artificial head. One could obtain almost identical stereophonic effects this way, on the condition that the microphones were positioned approximately three times as far apart as those on the artificial head. Although the separate microphones had the advantage of allowing for a quick change in the distance between them when making a transition from one image to the next, the artificial head was still preferred because it resulted in more precise sound images.

Although the Philips-Miller cellophane print playback units described above were never produced commercially, stereophony found its way into people's living rooms eventually. On June 15, 1946, the Stichting Radio Nederland (Netherlands radio foundation) started a series of experimental stereophonic radio broadcasts that used two stations (Hilversum I and II) to transmit the left and right channels separately. To hear these programs in stereo at home, one needed two receivers. The experiments were carried out in collaboration with Philips Research Laboratories, represented by De Boer. At the time of the June 15 broadcast, it was claimed to be the first stereo broadcast in the world,<sup>54</sup> but the assertion is questionable.<sup>55</sup> In an article in the Dutch newspaper *Trouw*, the announcer introduced the broadcast by explaining how listeners should position the two radios in their living rooms. Then, they were to close their eyes, and they would feel as if they were in the concert hall:

The sound of the grand piano will come from the left at the height of the tea cabinet, while the timpani player will seem to be standing on the sofa. Plaintive violins will sound softly from behind the wallpaper; a trumpet will blare from beneath the chair by the fire.<sup>56</sup>



*Fig. 1.26: To illustrate the efficiency of recording on cellophane tape, a reel capable of containing an hour of stereophonic music was shown next to the ten 78 rpm phonograph records of 25 cm in diameter needed for the same amount of music in mono.*

## Synthetic Sound

Synthetic sound production was a subject of discussion at Philips Research Laboratories long before the acoustics department began housing an electronic music studio in 1956. An article in *Philips Technical Review* by Schouten entitled "Synthetic Sound" described a striking example of a device developed to produce sound with a variety of waveforms.<sup>57</sup> Schouten had previously shown how sound recorded on film could be immediately analyzed into its different sinusoidal components.<sup>58</sup> By reversing that process, he had now developed a device, the optical siren,<sup>59</sup> that could synthesize a periodic sound of prescribed character – in other words, a sound consisting of sinusoidal components of a prescribed amplitude and phase. Although the siren had been designed primarily for the investigation of physiological acoustical problems, such as the influence of phase on sound perception and nonlinear distortion in the ear,

it would later be used as a sound source in electronic music productions at Philips Research, such as Henk Badings' *Käin en Abel* in 1956 and Tom Dissevelt's "Vibration" in 1959. It was the variety of tone colors the device could produce that made it attractive to use even now that fully electronic tone generators had become widely available.

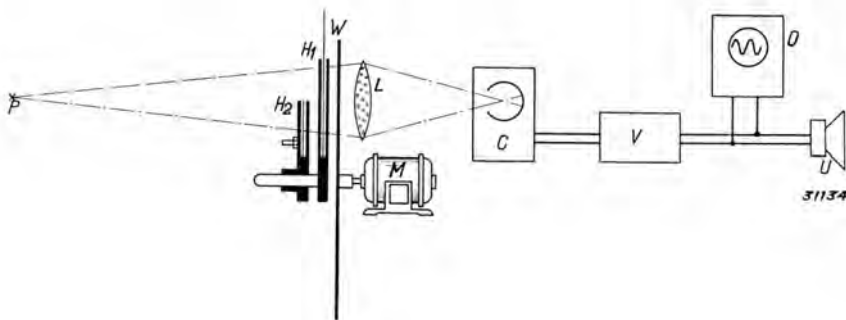
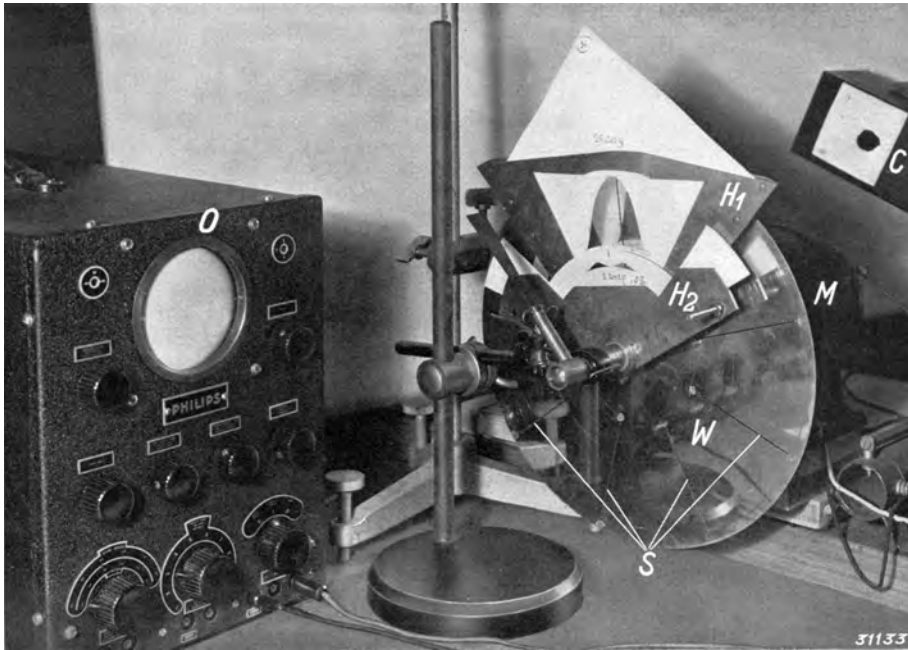

Fig. 1.27 and 1.28: Machine for the production of synthetic sound. Slits (S) were made in a disc (W). Two stencils for different sinusoidal vibrations were placed in holders ( $H_1$  and  $H_2$ ).  $H_2$  was for special experiments and could be rotated in relation to  $H_1$ . Light came from a point source (P). A motor (M) drove the disc. A lens (L) focused light transmitted through the slits on the photoelectric cell (C). There were also an amplifier (V) and a loudspeaker (U). The waveform of the synthesized sound could be monitored on the oscilloscope (O).

Tone generators that could produce pure sine waves were in use at Philips Research Laboratories by 1939 and were deployed in loudspeaker development (see Chapter 1, 18–22). A typical way of measuring nonlinear distortion caused by a loudspeaker is still to play sine waves of various frequencies through it and then analyze the output signal. Since a sine wave has only a fundamental frequency, any harmonics that appear in the measurement are caused by the loudspeaker (that is, assuming other elements in the chain, such as microphones and amplifiers, are virtually distortion-free). Originally, the tone generators used for this purpose were large, custom-built and part of a permanently installed system at Philips Research Laboratories (see fig. 1.6). But in 1940, a new type of tone generator was introduced that was compact and available as a commercial product. An article about the new Philips GM2307 tone generator made reference to Schouten's optical siren.<sup>60</sup> Although Schouten's system was capable of producing pure sine waves within a wide range of frequencies, it was not considered suitable for measurements on an industrial scale, where easy operation and mobility were desired. By basing the GM2307's design on the so-called heterodyne principle, the company was able to make a machine that could produce electrically generated sine waves within a range of 30 to 16,000 Hz and still be portable.<sup>61</sup> The 1940 version was used in the production of Badings' *Kain en Abel* in 1956 and later installed in the studio at Technische Hogeschool Delft, which opened in September 1957 (see Chapter 9). A second version of the GM2307 was used in practically every other piece of electronic music produced at Philips, including Edgard Varèse's *Le poème électronique*.

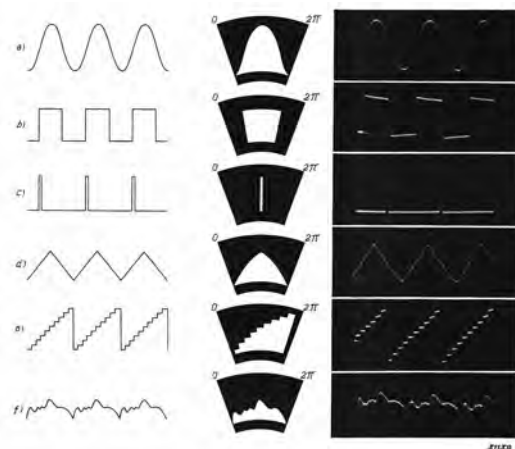

Fig. 1.29: Different waveforms with their corresponding stencils and the oscillograms obtained. A) was a pure sine wave; f) had the profile of a human face.



Fig. 1.30: First version of the Philips GM2307 sine wave generator. The large knob on the left was used for the coarse setting of the frequency, the large knob on the right for fine-tuning.

## The Philiolist Loudspeaker Violins

The Philips company's enormous expansion after 1900 caused great social and cultural changes in the city of Eindhoven. To accommodate workers' growing need for entertainment, it built the Philips Ontspanningsgebouw (Philips recreation building), which opened in November 1929. The original design incorporated a library, a reading room, various large and small conference rooms, a billiard hall, a kitchen, and two dining halls for seven hundred and eight hundred people respectively. After construction had begun, it was decided that the

upper dining room would be turned into a concert hall and theater. On November 15, 1930, the newly founded Philips symphony orchestra, Fidelio, gave its first performance. The conductor, Jan Düring, also played the solo part of Henri Vieuxtemps' *Ballade et Polonaise* for violin and orchestra. In 1934, the company decided to renovate the provisional theater into a real one. Vermeulen and De Boer were responsible for the acoustics;<sup>62</sup> the interior was designed by Kalff.<sup>63</sup>



Fig. 1.31: The theater at the Philips Ontspanningsgebouw after the 1935 renovation.

Vermeulen, a decent violinist himself, played in the Philips Symphony Orchestra from at least October 17, 1935, the date

of the first concert in the new hall, a performance of Mozart's *Violin Concerto in D*, again featuring Düring as a soloist.<sup>64</sup> In 1940, Vermeulen addressed a very specific problem of modern concert performance practice. He observed that while the violin had remained unchanged since the sixteenth century, concert halls had become much larger, and so had audiences. Therefore, there was a demand for much higher sound levels. He stated that this was obviously why orchestras had made themselves larger by multiplying the number of instruments that simultaneously played the various instrumental voices in a score. Yet this solution could not be used for virtuoso solo parts, such as those in concertos for violin and orchestra. According to Vermeulen, if there was a way of increasing the violin's volume while maintaining its other sound qualities, every solo violin player would endorse it as a much-appreciated improvement. Amplifying a violin with a microphone, as one would a jazz singer's voice, was not desirable, since it would change the color of the instrument significantly and limit the musician's freedom of movement. Therefore, he believed a kind of pickup, similar to that on a phonograph, might be a better solution. However, the only place where all the violin's vibrations could be picked up was the bridge. But the sound there could never represent the sound of the instrument, since it had not yet passed through the body of the violin, which determines its char-

acteristic color. If these vibrations were reproduced through an ordinary loudspeaker, Vermeulen wrote, the sound would not correspond to the violin's at all. His conclusion was that a violin's body had to be used as a loudspeaker. The vibrations of the bridge of the solo violin would be transmitted to secondary violins, which would then radiate the sound as if it were being created by the string vibrations of the first violin.<sup>65</sup> Vermeulen concluded his article by stating that small differences in timbre between the secondary violins, and the wider spread of their radiating surface, might change the listener's impression. Whether such a change was acceptable, or perhaps even an improvement, was a question that could not be answered on the basis of tests in a laboratory.<sup>66</sup>

After the tests, during World War II, a public demonstration of six "loudspeaker violins" with Jan Düring performing as a soloist was scheduled but canceled due to wartime conditions. Philips Research Laboratories did not continue to do research in this field. After electronic music appeared on the scene, the loudspeaker violins were abandoned as relics of a more traditional era. In 1960, five of the original six were donated to the Eindhovense Muziekschool (Eindhoven music school),<sup>67</sup> where Vermeulen had been president of the board from 1946 to 1951.<sup>68</sup>



*Fig. 1.32: Loudspeaker violins.*

## Chapter 2

# After World War II: Towards Electronic Music

### “Canned Music” and a Music Laboratory

Immediately after the end of the Second World War, in an internal Philips Research Laboratories report, Vermeulen made a strong plea for opening a new music center in Eindhoven. A music laboratory would play an important role in the center, which would work with the Philips orchestra, a local music school and a provincial conservatory. Music education at this conservatory should, he argued, include subjects related to microphone and recording techniques. Vermeulen’s report opened up new perspectives on the aforementioned developments in electroacoustics and shed light on his motivations for the projects he would initiate during the years to come. The ten-page report started with some historical background and a view of the future:

Art, science and culture in general will remain unmistakable elements in enabling a quick recovery of the resilience of our people. [...] Without doubt, we are looking at the birth of new social and economic relationships, which can best be described as the emancipation of the working classes, just as the French Revolution at the time implied the emancipation of the bourgeoisie. This will not necessarily lead to a dictatorship of the proletariat but rather to a relatively larger share for the workers of the fruits of communal activity. It will be essential for balanced, peaceful development that not only the material fruits fall to the new layer of the population but that this layer also has access to the spiritual and cultural values that underpin our society. It can be no coincidence that this development, caused by the improvement of production methods and the flourishing of science and technology, occurs at a time when industry is becoming capable of serving such a numerous group on such a large scale.<sup>69</sup>

Vermeulen continued by describing the social and cultural consequences of the recent changes. He also introduced the term “canned music,” addressing the consequences for musical performance practice should electronic reproduction be introduced as a new standard for music distribution.

For the Philips company, as a manufacturer of musical instruments, it will be especially important to find out how this art form will adapt to the new social relationships. The fact that we consider radio receivers, phonograph players and sound film projectors as musical instruments is essential to our vision on



the future of music, which will consist mainly of “canned music.” [...] Now, the possibility has been created for music to develop from a hothouse plant surrounded by worries into a healthy, living form of art, which, like literature, will only need incidental financial support. The mass production that will make this possible will cause an even greater loss of direct contact between the artist and the audience than is already the case in large concert halls. But in literature no one would say it is only possible to enjoy a verse or story by listening to a personal recitation by a narrator. [...] It is understandable that musicians will dislike the prediction that electronic reproduction will become the standard way in which their work will be distributed to the audience. [...] We can already sometimes observe the phenomenon of music lovers preferring a phonograph record of, for instance, Toscanini over [a live performance by] a provincial orchestra. On the other hand, is it not monstrous, from an economic and artistic point of view, that a hundred artists have to copy the same works on stage night after night? And is it not incomprehensible that there is less opposition against such drudgery than there is against a factory worker’s job on an assembly line, which is so often criticized in artistic circles?<sup>70</sup>

Vermeulen not only foresaw big changes in the practice of music performance; he believed music education should change substantially as well. He cited the relationship between the conductor Leopold Stokowski (1882–1977) and Bell System Laboratories as an example. Philips established contact with Stokowski that same year, and his pioneering work greatly influenced Vermeulen’s research for the “Multiplication of Concerts”<sup>71</sup> (see Chapter 2, 50–3).

Research work will be of utmost importance in leading music in a direction by which the mass product will provide more than just cheap pleasure for many. [...] The most powerful means of widening interest in music will undoubtedly be the radical improvement [...] of music education in primary schools, where the usually inane singing lessons will have to be replaced by a systematic “common formative music education.” [...] On the other hand, particular attention will have to be paid to the special techniques required by the use of a microphone. For a singer, a top priority will no longer be the ability to “fill” a large concert hall with her voice but rather the ability to express herself musically without overloading the equipment by belting a song out too loudly. The conductor and the composer, too, will have to learn which limitations are imposed on them by the technique of reproduction, and they must search for the new effects it has made possible. In America, Stokowski has already done work in this direction with Bell System Laboratories.<sup>72</sup>



In the last part of his report, Vermeulen proposed a new role for composers: they should receive commissions but strive less for eternal fame and serve society more. He questioned the role of the government as a driving force for the arts and underlined the benefits of Philips' exertion of influence on the further development of modern music.

We hope and expect that, as a result of the work in the music laboratory, with these new possibilities at his disposal, the composer will find a way into the hearts of the people once again. This will be easier for him if better education leads to better understanding of his work. Then, the tradition that has existed since classical times of preferring the performance of new compositions will be restored. The composition itself will thus once again become more important than the performer's virtuosity or differences in the interpretation of very well-known pieces, which currently dominate the concert world. The fact that such a music laboratory will also be of interest to the Philips company needs no further explanation. [...]

If the music center is to fully achieve its goal, that of presenting music to the audience in a lively new form, then composers in particular must be involved through the giving of commissions. There is a very small audience for modern works, namely those people already saturated with classical music, such as music reviewers. To restore contact [with the audience], composers should strive less for originality and works that will survive into eternity but rather, like good journalists and authors, aim their work at educating the public's understanding and taste, even if this means many compositions will last no longer than an article in a magazine. In the "canned music" of the future, copyright will no longer form an insurmountable obstacle. [...] It is questionable whether the government is the appropriate institution to stimulate and drive the arts; we have more faith in the creative force of the guiding institutions of today – the great companies, and more particularly the film and radio industries. Just as the names of Esterhazy and Lobkowitz are still known because of their relationships with Haydn and Beethoven, it is not impossible that in later years, the name of Philips will derive more fame from its influence on modern music than from the industry that made that music possible.<sup>73</sup>

## Collaboration with Leopold Stokowski

Leopold Stokowski published the book *Music for All of Us* in 1943.<sup>74</sup> Although Vermeulen mentioned Stokowski in his proposal for a music laboratory, it is not clear whether he had read Stokowski's book in 1945. There are, however, clear similarities in the two men's thinking.<sup>75</sup>

In his first chapter, "Music the Universal," Stokowski described a way in which technology had solved a problem that had resulted from a sociological development:

Formerly music was chiefly confined to privileged classes in cultural centers, but today, through radio and records, music has come directly into our homes no matter how far we live from cultural centers. This is as it should be, because music speaks to every man, woman, and child – high or low, rich or poor, happy or despairing – who is sensitive to its deep and powerful message. [...] Today there are millions interested in music, where there were formerly a few thousand.<sup>76</sup>

Stokowski also addressed technical topics of interest to Vermeulen and his department. In Chapter 15, "Reflection and Absorption – Echo and Reverberation," he wrote:

In the future, it will be possible to build concert halls and studios for radio and recording that have variable acoustics. [...] In the future it will be possible to pick up and amplify any zone of frequency, and prolong it by reverberation. [...] This will not be done by reflection, but by an electrical process.<sup>77</sup> (See also Chapter 2, 50–3)

In *Music for All of Us*, Stokowski described a whole category of "electric instruments." This brings to mind the fact that he had been in contact with Edgard Varèse (1883–1965) at least since 1922. In that year, Varèse had sent him the orchestral score of *Amérique* in the hope that Stokowski would conduct the work.<sup>78</sup> He did not do so, but he conducted Varèse's *Hyperprism* in 1924 and, a year later, the premiere of *Intégrales*.<sup>79</sup> Varèse used electronic musical instruments in 1934 in *Ecuatorial*, which was composed for a bass voice (replaced by a male chorus in the second version), four trumpets, four trombones, piano, organ, percussion and two electronic theremins<sup>80</sup> (replaced by two electronic ondes Martenots<sup>81</sup> in the second version). In Chapter 21 of *Music for All of Us*, entitled "Instruments of the Past – Present – Future," Stokowski wrote:

Today we are at the verge of one of the greatest steps in the evolution of musical instruments that perhaps can ever take place – that is, the invention and development of musical instruments in which the tone is produced electrically, but is played and controlled through musician's feeling, technical skill, and intuitive understanding. [...] It is probable that some electrical instruments will be played by keyboards [...] because instruments of this type will make it possible to play rapidly a series of tones with great precision and certainty. But some types of melodies, where one tone glides to another with a curved motion,

will possibly be played on a wire somewhat like a cello string, or by electrical instruments similar to those invented by the Russian Theremin or the French musician Martenot.<sup>82</sup>

Before publishing his book, Stokowski had been involved artistically and technically in the creation of Walt Disney's motion picture *Fantasia*, which premiered in November 1940. It consisted of animation set to classical music without any dialogue.<sup>83</sup> Originally, *Fantasia* was planned as a standard one-reel short movie, but it eventually became a multi-million-dollar road show. Its performance required the largest sound reproduction system that had been used commercially in the theater up to that date.<sup>84</sup> The music was recorded at the Philadelphia Academy of Music under the direction and supervision of Stokowski,<sup>85</sup> using an eight-channel recording technique. Violins, violas, cellos and basses, woodwinds, brass and timpani were recorded "dry" on separate channels with very little distance between the microphones and the instruments, while the eighth channel recorded the entire orchestra from a distance, along with the reverberation of the hall.<sup>86</sup>

The Fantasound road show equipment was designed by sound engineers William E. Garity and John N. A. Hawkins. It could reproduce the multi-channel recording of the music in sync with the projected images. By the time of *Fantasia's* release, the Fantasound equipment had been built and tried out in ten different versions with various loudspeaker configurations and different operational controls.<sup>87</sup>

Initially, the plan was to manually operate the road show equipment during each screening of the movie. The sound could, for example, be moved smoothly around the theater. But the system became too complex to operate manually, and it would have been difficult to keep all the shows alike. To get around these difficulties, a pilot tone control arrangement was devised. The manual control was replaced with a tone-operated gain-adjusting device (TOGAD). The system had eight control tones on the control track, logarithmically spaced from 250 to 6,300 Hz.<sup>88</sup> It required a floor space of approximately thirteen square meters, and it used nearly four hundred vacuum tubes. However, during the world premiere at the Broadway Theater in New York, six live program mixers were still needed; together, they controlled a total of twenty-four program circuits.<sup>89</sup>

The book *Music for All of Us* and the film *Fantasia* came out during the German occupation of the Netherlands. Activities at Philips Research Laboratories had not come to a complete halt in those years, but the number of scientific publications and colloquia participated in by scientists had significantly declined. By appointing two German *Verwalter* (administrators), the German authorities in The Hague and Berlin had gained a major say in the company's activities. Philips had only a small directorate in the Netherlands, headed by Frits Philips, working under German rule; Holst was made responsible for technical and scientific policy at Philips Research. The company's main directors had fled to New York in May 1940.<sup>90</sup> Considering Philips' own interest in film sound and projection techniques, the ambitiousness of Fan-

tasound and the scale on which the *Fantasia* project was realized must have made a big impression on the company. Holst and Vermeulen were informed about the technology behind the Fantasound system, presumably through Philips' New York representatives.

After World War II ended, Holst met Stokowski on a visit to the United States in 1945. Stokowski then wrote a letter to Holst on December 20, 1945, which indicates that during their meeting the scientist had told the conductor about the advances in recording and reproduction techniques at Philips. Stokowski wrote:

I am often thinking with enthusiasm of the wonderful possibilities opened up for ideal recording of symphonic and operatic music by what you said at our meeting in New York. With a frequency range from 30 to 13,000 c.p.s.,<sup>91</sup> with a volume range of 40 dB, with binaural recording and reproduction, and with long playing so that a whole symphony or an act of an opera can be intact, I am convinced that entirely new possibilities will be opened up for the enjoyment of inspirational music all over the world.<sup>92</sup> I forgot to ask: Will it be possible to keep every form of distortion and extraneous sound down to an extreme and practically inaudible minimum? Distortion often affects timbre in a most disturbing way. In my opinion purity of timbre is important in two ways. One, to convey and reproduce the timbre of existing instruments with all the variety with all their various registers. Two, to reproduce perfectly the timbre of electrical instruments which will be invented in the future. I am certain these electrical instruments will produce many timbres which exist as potentialities in nature but which no musical instrument at present can produce.<sup>93</sup>

Shortly after Holst's discussion with Stokowski, Vermeulen started to develop what would soon be called the "Stokowski installation" around a stereo version of the Philips-Miller recording system. Eventually, the sonic result would be described as "Stokophonie"<sup>94</sup> (Stokophonics).

On February 3, 1946, Vermeulen wrote in his journal that H. J. R. G. Hartong (1904–1992), the commercial director of Philips' HIG Apparaten (main industrial division for machines), had instructed Numann to invite Stokowski for a visit to Philips. Holst worried that the time was not right, since the company might not be able to demonstrate enough progress on the Stokowski installation.

To meet the conductor's demand for a wider frequency range, a proposal was made that the range be split into three parts – for instance, 50–3,500 Hz, 3,500–7,000 Hz and 7,000–10,500 Hz – and the two higher ranges then shifted back to 0–3,500 Hz by means of frequency transformation. Thus, no special chisels for the Philips-Miller recorder would be necessary for writing the higher frequencies onto Philimil film. Another requirement was that all the equipment had to be transportable, since the recordings with Stokowski were to be made at the Concertgebouw in Amsterdam.<sup>95</sup>

Holst wrote back to Stokowski, explaining that their chief acoustic engineer's illness had prevented them from starting immediately on the modifications of their recording equipment needed to meet the conductor's requirements, but that they hoped to be ready before July 1, 1946. He expected that the total distortion of the modified system could be kept so low as to be practically inaudible, while the noise level would be very low as well. Moreover, the installation would incorporate binaural (artificial head) techniques. According to Holst, binaural reproduction was favorable in this case, because it would mean the last traces of noise would not be annoying, since they would seem to be coming from a different direction than the sound. He guaranteed to Stokowski that all Philips' engineers would do their utmost best to make the experiment a big success.<sup>96</sup> Nevertheless, the installation was far from ready in July.

Vermeulen's journal of September 4, 1946, contained many details about the progress made in building the Stokowski installation, divided by subject; topics included the construction and measurement of new amplifiers, microphones, loudspeakers, the artificial head microphone, mixing and control decks, and new writers (chisels) for the Philips-Miller recorder.

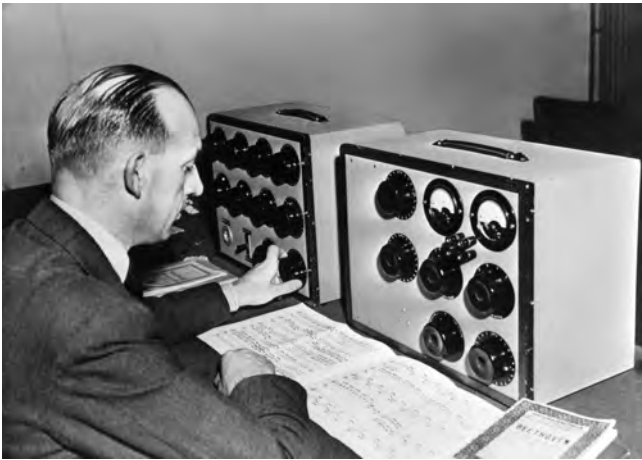

*Fig. 1.33: An Expressor operator. Compression was applied according to the musical score, based on experience gained in rehearsals.*

New writers were necessary for increasing the frequency range of the recordings; the previously proposed technique involving frequency transformation was not mentioned further.

Vermeulen also described the Expressor, which had been developed to meet Stokowski's demand for a larger dynamic range. Three years later, the Expressor technique was explained in an article in *Philips Technical Review*.<sup>97</sup> It basically consisted of dynamic compression during the recording of music and expansion during playback and was more or less similar

to compander technologies for automatic noise reduction introduced many years later, such as Dolby A (1966), DBX (1971) and Telcom (1975). However, the article argued that better results were obtained when compression was carried out manually by an experienced professional rather than automatically.

The operator of the Expressor would follow the performance by reading the musical score, bringing up the recording level during quiet passages and bringing it down during loud ones. The movements made with the knob were recorded on a separate channel of the Philips-Miller tape. During playback, the signals would control an automatic expansion circuitry, thereby restoring the original dynamics of the performance.

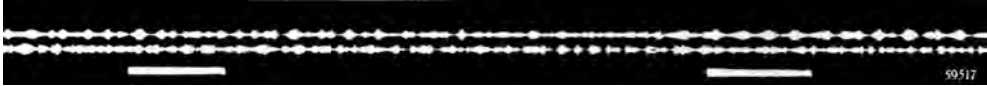

*Fig. 1.34: A part of a Philips-Miller tape of a stereophonic recording. Underneath this track, one sees the markings (control track) resulting from the movement of the compression potentiometer. During playback, these markings caused the expansion potentiometer to move in the opposite direction.*

## **Leopold Stokowski and Roelof Vermeulen at the Concertgebouw**

On December 14, 1946, Vermeulen presented a new research program proposal to the acoustics department of Philips Research Laboratories. The first section, “Conclusion of the Current Program,” dealt with the Stokowski installation, which was due to be ready for use in April 1947. Test recordings should then be made, after which the Concertgebouw Orchestra and Stokowski should be contacted again. According to Vermeulen, the installation had in any case been useful as a spur for the improvement of the Miller writer and the development of the Expressor. The experience gained could also be used in a number of tests, whose outcomes should be recorded as numerical data as far as possible, Vermeulen argued. He considered all this necessary “for creating guidelines and clarifying understanding on points where much money is often currently spent, on the basis of intuition and belief, on improvements that are perhaps superfluous.”<sup>98</sup>

A letter Holst sent Stokowski in the following month indicates that Stokowski had announced he would come to Amsterdam to conduct the Concertgebouw Orchestra on May 22, 1947. Holst had by now retired from active service as a director of the Research Laboratories. Vermeulen thus wished to discuss methods of recording symphonic and operatic music with Stokowski in place of Holst.<sup>99</sup> Vermeulen, who became director of acoustic research that year,<sup>100</sup> wrote to Stokowski on March 10, 1947:

Prof. Holst has informed me about your anticipated visit and has requested me to give you some further details about our recording methods and the tests we should like to make during your stay in Holland. [...] Last summer, we had some preparations made for these experiments but since you had to postpone your visit we seized the opportunity to make some further improvements. [...] This improved equipment has just left our workshop and we will make every effort to have it in perfect working order at the date of your visit and expect that it will give you full satisfaction. Without going too much in detail, we give you below a short description of the layout of the equipment. The monitoring-desk has been provided with facilities for the use of two of our new stereophonic microphones [the so-called “artificial heads”] and two single microphones for spe-

cial mixing purposes. The position of these microphones in the sound image can be changed at will from the monitoring desk. We made a special arrangement for the possibility to enhance the bass, down to a frequency of 30 c/s. During a test performance (for instance during one of the rehearsals) we intend to give you the desired reproduction in accordance with our expert judgement, right at the monitoring desk. The technical adjustments, required to avoid overloading during recording, will be automatically compensated in the reproduction of the recording [with the Expressor]. Thus an undistorted reproduction of the intended effects will be obtained. We believe that in this way we will have the very best recording possible.<sup>101</sup>

Stokowski looked forward to studying the new stereophonic microphones and to conducting the tests in rehearsals and a final concert, as suggested by Vermeulen. In a letter to Holst two days later, Stokowski mentioned that he would like the tests to be “purely scientific and uncommercial.”<sup>102</sup>

While Vermeulen and Stokowski focused mainly on the research aspect of the project, Hartong apparently emphasized the commercial side. According to him, its purposes were: 1) to research the possibility of cutting phonograph records from a Philips-Miller recording, 2) to sell music on Philips-Miller tape, and 3) to compare a ten-to-twelve-minute cellophane print<sup>103</sup> with a transcription disc<sup>104</sup> of the same recording.<sup>105</sup>

Though Stokowski had written to Philips that he wanted the tests to be purely scientific, he also understood the commercial aspects. He was convinced that his collaboration with Philips would “revolutionize the recording of symphonic music all over the world.”<sup>106</sup> He believed that

the outcome of the tests [would] [...] put Holland in a foremost place in the whole world with regard to the recording and reproduction of symphonic and operatic music. [...] Later they will bring to the artists in the Concertgebouw many engagements for recording symphonic music in such a way that the records can be made available to music lovers all over the world.<sup>107</sup>

Vermeulen’s journal entry of March 31, 1947, mentioned a meeting with Hartong, Holst and others, scheduled at Hartong’s request. Hartong was not at ease with Philips’ view on the importance of the tests. He pointed out that the company was getting involved in the music business and that the tests with Stokowski would cause upheaval in that field. According to Hartong, the tests’ results would entirely determine Philips’ position: if they proved successful, that position would become very strong. Therefore, the Stokowski project should be given a high priority.<sup>108</sup> Hartong had taken over the business side of the tests, and from then on, Vermeulen would take care of only the scientific and technical aspects. In 1950, Hartong initiated

the founding of Philips' Phonographic Industries (PPI),<sup>109</sup> which in retrospect can be seen as a direct result of the project with Stokowski.

The Concertgebouw Orchestra's 1947 Dirigentenserie (conductors' series) included the May 22 concert conducted by Stokowski, featuring music by Johann Sebastian Bach, Ludwig van Beethoven, Paul Creston and Richard Wagner. It also included two performances conducted by Eduard van Beinum (1900–1959), one on May 8, with music by Claude Debussy, Joseph Haydn and Willem Pijper (1894–1947), and one on May 29, with music by Béla Bartók; a concert conducted by Henri Tomasi (1901–1971) on June 5 (program unknown); and a performance conducted by Paul Hindemith of his own music, on May 15. The Hindemith concert was successfully recorded, albeit without the Expressor and with ribbon microphones instead of the artificial head microphone.

On May 16, a stereophonic speaker monitor system was installed as well as possible in the Concertgebouw's small concert hall. That night, a concert performed by Yehudi Menuhin was recorded and played back to him. He was unhappy with the sound of the violin but enthusiastic about the recording of the orchestra the night before under Hindemith. On May 17, Stokowski arrived. Some recordings were played to him in the monitor room. Then, during rehearsal, excerpts were recorded and played back to him on the speakers in the small concert hall. His verdict was that there were too few high tones, the low tones were satisfactory, and something was missing between 1,000 and 2,000 Hz. That day, Holst, Hartong and Numann came to visit. In the evening, a demonstration was given for invited guests in the small concert hall. In it, another concert simultaneously being conducted by Hindemith in the large concert hall was reproduced live on the stereo speaker setup in the small hall. The members of the audience filled in a questionnaire, and their response was positive, although some complained that the stereophonic sound image was weighted toward the left or right side. The Philips technicians assumed this was the result of a deficiency in the acoustics, caused by the oval shape of the rear of the hall.<sup>110</sup> The violins were also considered not brilliant enough.

On May 19, another series of test recordings was made during additional rehearsals, this time with a combination of ribbon microphones and an artificial head microphone. Stokowski deemed the results much better, but Jaap van Ginneken<sup>111</sup> and M. J. C. van der Meulen<sup>112</sup> were not satisfied, as the brilliance of the violins was still missing. In tests in the following days, the distance between the ribbon microphones was increased empirically, until an optimal position was found. Finally, on May 21 and 22, Stokowski's concerts were recorded. On June 15, 1947, Vermeulen wrote a report for the people who had been involved in the project, entitled "Philips Stereophonic Recording Experiments with Mr. Leopold Stokowski in the Concertgebouw in Amsterdam." The report stated:

It is not often that an artist is found to take any particular interest in technical matters, not even when these may open up new perspectives for his particular form of art. One of the exceptions to the rule is the orchestral conductor Leopold



Stokowski, who has not only assisted in the production of several sound films [...] but has also taken such a deep interest in the technical side of sound recording and reproduction that he has become quite familiar with the language of the engineer. [...] His visit to the Netherlands therefore afforded our experts in acoustics an excellent opportunity to exchange views with such a famous musician and to check developments in sound technique with his ideas.<sup>113</sup>

The report further described the need to avoid distortion and noise in electroacoustics, which remained a troublesome feature of “canned” music.<sup>114</sup> Vermeulen described the Expressor technique as a solution, again emphasizing that the system should be operated by a musician rather than through an automatic circuitry that “cannot see into the future.” For Vermeulen, the most important conclusions of the experiments were that:

Even the full and truthful recording of the musical notes still does not give a satisfactory reproduction of a musical performance. [...] It has therefore been the aim in further research work to approximate this space effect of the original sound impression, or in other words to enable the listener to distinguish the various directions from which the sound reaches the ear. The solution of this problem has been found in “Stereophony” and also in the “dummy head” – in which two microphones are set up for differentiating between the various directions. [...] The experiments conducted in co-operation with Stokowski were very instructive, because they showed it needs not by any means necessary to aim at an exact reproduction of the music as it is heard in the auditorium where the concert is actually given. As a matter of fact there had already been some doubt as to that necessity in technical circles. Experiments carried out in America and elsewhere had shown that full reproduction of the very highest notes is desired neither by the public nor by the musicians.<sup>115</sup> Such a result was not confirmed in Amsterdam. Perhaps it was owing to the low level of disturbing noises, or maybe to a different taste, but anyhow in this case the fullest possible reproduction of the high note scale was judged to be desirable. On the other hand, Stokowski was of opinion that in the orchestra the bass notes are always too weak and that only the organ is capable of producing the bass part in sufficient volume. [...] But the most interesting of all was Stokowski’s idea that the music as heard in the concert hall is only a compromise and does not by any means represent the ideal sound picture. [...] Reproduction from loudspeakers, however, offers entirely new possibilities, because it leaves much more freedom in the placing of the sources of the sound. Music should not reach the ear from one direction, as it does in a concert hall. The listener should be surrounded by it, receiving no impression of direction at all but being bathed, as it were, in the music. [...] For many it will indeed be a strange experience to hear an orchestra

in this way, accustomed as we are since so many generations to hearing the sound from one place in the hall, but it is none the less certain that with such a sound picture, very remarkable results are to be attained, which will probably represent better the music as heard by the composer when he created it.<sup>116</sup>

Here, as in *Music for All of Us*, the ideas of Varèse seem to have entered Stokowski's mind, for Varèse had dreamed earlier about a machine that would create "a sense of sound-projection in space by means of the emission of sound in any part or in many parts of the hall."<sup>117</sup>

Based on the experiments with Stokowski, Vermeulen came to understand that the musical value of stereophony lay in its superior differentiation between instruments compared to that which could be achieved by means of their timbre alone. However, while stereophony could produce a satisfactory imitation of the sound of the orchestra, it could not give the experience of a live concert. An additional technique was necessary for creating a satisfying spatial illusion, which Vermeulen would call "ambiophony."<sup>118</sup> Research into ambiophony and variable acoustics using electronic reverberation systems would dominate his scientific work for years to come.

To solve the problem of the insufficient loudness of the bass instruments in the orchestra, Stokowski proposed a keyboard bass instrument with a device that would allow the player to "glide from one tone to another without separation," i.e., to make a glissando. But Vermeulen suggested keeping the traditional double bass and picking up the vibrations of the bridge, amplifying them and feeding them to a set of speakers, so that the technique of playing the instrument could remain the same.<sup>119</sup>

From April 10 until June 22, 1948, Vermeulen visited the United States, where he saw Stokowski. Stokowski was interested in the progress of Philips' "Stokophonie" recording system, which he found remarkable. He considered it especially important that the reproductions be suitable for home listening and favored the idea of Philips becoming active in this field in the United States. He was

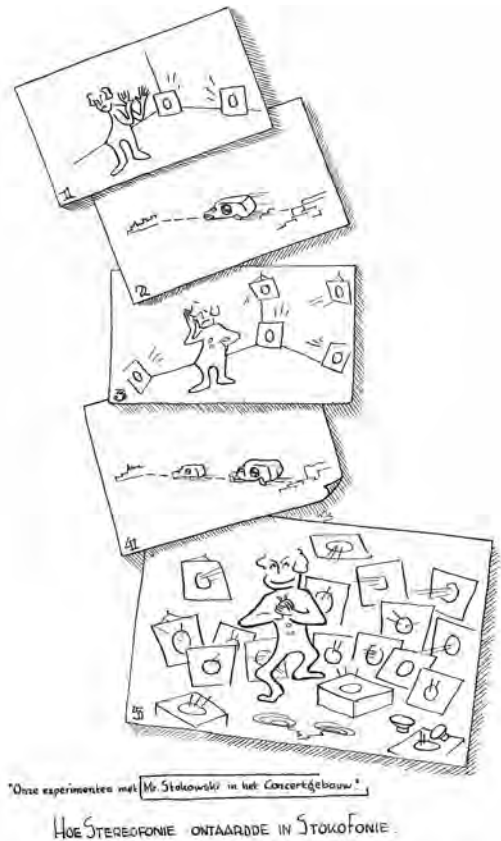

Fig. 1.35: Cartoon from an album made for Vermeulen's 25th anniversary at Philips in 1948. ("Our experiments with Mr. Stokowski in the Concertgebouw." How Stereophony degenerated into Stokophony.)

not happy with the fact that in the US, competition had led manufacturers to try to manage on the lowest possible budget, as long as the public did not complain. By contrast, he was under the impression that Philips strove for the highest possible quality and succeeded in achieving it without looking at competitors. A second subject he wished to discuss with Vermeulen was microphones. Stokowski was convinced that besides nondirectional microphones, there should also be microphones with a narrow focus, so that different instruments in the orchestra could be accentuated. They also discussed the bass instrument. Stokowski said it should be able to generate a high intensity, allow for glissandi and play fairly fast. In addition, it should give an almost pure tone, with low harmonics, and he therefore objected to the amplification of a double bass, which produces high harmonics. In connection with this, he referred to "an instrument by Mr. Martenot in Paris, who plays it himself and has patents on it. His sister plays it even better." According to Stokowski, Martenot would certainly be willing to demonstrate it to Philips, and the company could mention Stokowski's name.<sup>120</sup>

## Multiplication of Concerts

*Philips Technical Review* of June 1948 contained an article by Vermeulen called "Multiplicatie van Concerten," (Multiplication of concerts) in which the results of the experiments with Stokowski were finally presented to the public. According to the article, the experiments had shown that a duplicated concert could provide musical pleasure approaching that experienced at the original concert. On a number of points, the "copied" concert could even be called superior to the original. The main external difference between the two in the experiments had been the lack of visual contact between the audience and performers.<sup>121</sup>

In his explanation of the concept of concert multiplication, Vermeulen began with some sociological remarks, as he had in his 1945 proposal for a music laboratory. He wrote that despite the confusion around us, a trend could be identified in society: advances in technology were creating means by which larger and larger segments of the population could obtain a certain degree of wealth. To prevent this development resulting in barbarism, it was important to make sure that this wealth did not limit itself to material goods: the working classes, Vermeulen wrote, "should be given access to the domains of the mind and spirit as well."<sup>122</sup> The situation that could be expected in the future, and that one already confronted on certain occasions today, was that even large halls would be much too small to accommodate the numbers of people wanting to attend concerts. Instead of larger halls and orchestras, radio broadcasts and live amplification, he proposed the multiplication of concerts in another hall or even multiple halls as a solution.

In the section "Experiments and Results," Vermeulen mentioned that almost everyone who had listened to a duplicated concert had considered the degree of musical pleasure it afforded to be much higher than that provided by a radio broadcast, and to an extent compa-

rable to that enjoyed at an original performance. In the questionnaire, 85 percent of the subjects rated their appreciation of the sound of the orchestra as “good,” and 15 percent rated it “moderate.” Asked whether it was possible to enjoy music in this way – leaving aside the question of whether the sound of the orchestra had been accurately reproduced – 95 percent said “yes.” The subjects generally experienced the spatial effect of stereophony as a big improvement, not in the first place because of an increased ability to localize sound sources or follow their movements but because of an increased ability to recognize the instruments with their different sound characteristics and to better distinguish reverberation and disruptive noises.

The final question asked the subjects whether they had perceived the physical absence of the orchestra as a deficiency. They were roughly evenly split: 39 percent said “yes,” 41 percent said “no,” and 10 percent actually said they considered the physical absence of the orchestra an improvement. In the experiment in the small hall of the Concertgebouw, the stage had been closed off by a thin white curtain, with the speakers set up behind it. There had therefore been no natural point of fixation for the eye. Vermeulen wrote that creating such a fixation without letting visual impressions distract the listener would probably be one of the main problems in concert multiplication. It seemed logical to expect a solution from television, which would enable transfer of the visual image of the orchestra to the subsidiary hall. Yet Vermeulen questioned whether this made sense: “Is watching a collection of toiling musicians truly the most suitable support for musical enjoyment?”<sup>123</sup> A simple solution for getting around the problem, though one that would probably be considered unacceptable in most cases, was to cloak the subsidiary hall in total darkness. This had been tried at the concert duplications in Eindhoven, and the general opinion had been that it allowed for better appreciation of the music. Apart from the relaxation darkness offered the eye, which would have otherwise searched in vain, it could also have the positive effect of removing an unconscious conflict between the acoustical and visual perception of the hall. Often, the subsidiary hall would be smaller than the main hall. Making it completely dark would cause visual impressions to disappear; the walls would be eliminated, so to speak, and one would have the impression of being in the much larger space of the main hall, which, Vermeulen stated, would leave its imprint on the reproduced music.<sup>124</sup>

When Vermeulen had visited Stokowski in New York, they had discussed the difficulty of choosing images to accompany a musical reproduction without an orchestra. Stokowski had explained how a solution had been found for illustrating Beethoven’s *Pastorale* in *Fantasia*.<sup>125</sup> He believed colors without too many shapes were most suitable for holding the eye. He strongly opposed Vermeulen’s suggestion of simply projecting an image of the conductor, since, as Stokowski said, the conductor “was merely a technical element.”<sup>126</sup>

Vermeulen considered it strange that during duplication, the technician at the mixing desk always tended to make the bass tones stronger than they were in the original performance.<sup>127</sup> Regarding the upper limit of the frequency range during reproduction, Vermeulen wrote that his team had learned from their experiments that human hearing was extremely sensitive to

errors in that frequency range, both of nonlinear distortion and of relative loudness levels. Omitting the frequency range above 4,000–5,000 Hz was probably preferable to incorrect reproduction. On the other hand, it could not be denied that these high tones were the ones that brought liveliness and character to music and gave the listener a sense of freshness and freedom. Therefore, they had decided to set the frequency limit at 8,000 Hz.<sup>128</sup>

Vermeulen made some interesting remarks at the conclusion of his article. According to him, there was a deeply rooted belief that art had such an esoteric character that technical equipment used to bring it to a large audience threatened to change the essence of that art. Granted that this was true, he said, who could predict whether the change would constitute an infestation and atrophy or, on the contrary, a positive development? Vermeulen found it reasonable to expect that the application of new technologies would not form a barrier to achieving new, unsuspected pinnacles in music. Maybe the new media would even trigger them. The project outlined in the article had in the first place been oriented towards reproducing the long-familiar sound image of a concert as faithfully as possible. However, he con-

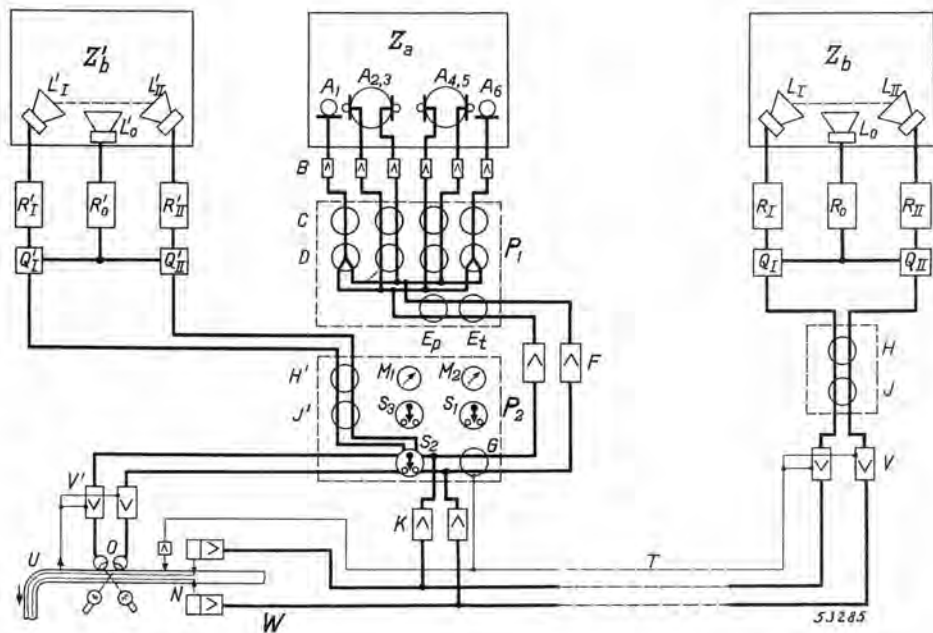

Fig. 1.36: The installation for the multiplication of concerts. In the main hall ( $Z_a$ ), the sound was recorded using two artificial head microphones ( $A_{2,3}$  and  $A_{4,5}$ ) and two ribbon microphones ( $A_1$  and  $A_6$ ). The microphone signals were amplified by six preamplifiers ( $B$ ) and then fed through the mixing desk ( $P_1$ ). A knob ( $E_p$ ) allowed for the increase in volume of low frequencies. The sound was then transferred to the subsidiary hall ( $Z_b$ ) over telephone lines ( $T$ ), either in real time or after a recording had been made on a Philips-Miller unit ( $W$ ). The sound was projected into the subsidiary hall through a stereophonic loudspeaker setup ( $L_1$  and  $L_2$ ), with a monophonic speaker for low frequencies. The control room ( $Z'_b$ ) in which the mixing desk ( $P_1$ ) was located had a speaker system identical to the one in the subsidiary hall.

sidered it possible that this limited objective would eventually be abandoned. As soon as artists saw that the technical means available to them could liberate the orchestra from its traditional limitations, they could begin using them to create entirely new musical impressions. Vermeulen ended by saying, "With this music of the future, in a literal sense, we may end these considerations."<sup>129</sup>

## **Ambiophonics and Reverberation**

The development of the Fantasound equipment for cinematic audio reproduction included different configurations, not only with multiple loudspeakers near the stage, but also in the corners and at the sides and ceiling of the hall. Several monitor speaker positions were also experimented with during the tests with the Stokowski installation in Amsterdam. Stokowski asked that the speakers at the front of the monitoring room be positioned off-axis and the ones at the rear be pointed upwards. After all, he had said that reproducing sound through speakers presented entirely new possibilities because it allowed much more freedom in the placement of sound sources. He argued that music should not reach the ear from a single direction, as it does in a concert hall; rather, the listener should be surrounded by it, receiving no impression of direction but instead being bathed in sound. The term "Stokophonie" seems to have referred primarily to this idea.

The Philips Research Laboratories acoustics department staff member L. Alons<sup>130</sup> found Stokophonics a strange experience and saw no way for a scientist to judge it properly because of the lack of any standard. According to Alons, the results "therefore [could] only be judged by a musician."<sup>131</sup> He also questioned the need of stereophony in this context, since all sense of directionality was lost. In a stereo sound demonstration for the BBC's superintendent of recording on the same day as Stokowski's experiment, the front speakers were restored to their normal horizontal position, while the rear speakers remained pointing upwards; Alons considered this a significant improvement.<sup>132</sup>

Vermeulen later wrote in his journal that with this configuration, something he had previously imagined had been achieved. The composers Sam Dresden (1881–1957) and Willem Pijper had once said to him that stereophony could not truly "surround" the listener with music. But he had now discovered that this could in fact be achieved without introducing an additional time delay. Instead, pointing the rear speakers upward was enough to keep from disrupting the stereophonic effect of the front speakers.<sup>133</sup> Some ten years later, in the article "Space in Music," Vermeulen explained the concept of ambiophony:

There are two different space effects essential to the complete enjoyment of music: first the differentiation between the directions of the direct sounds from the musical instruments, which can be simulated by means of stereophony;

second the diffuseness of the reverberant sound, which can be simulated by ambiophony. At the moment it is not yet quite feasible to introduce both stereophony and ambiophony in the home by means of the two channels that can be recorded in the single groove of the phonograph record. It is therefore an important problem to establish which of these two produces the musically most essential effect. [...] There are, however, indications that ambiophony may be the more essential.<sup>134</sup>

For Vermeulen, stereophony, ambiophony, diffuseness of sound and reverberation were apparently closely related subjects within the context of research in acoustics. As part of this research, Philips had invented a technique that employed scale models for the study of theater and concert hall acoustics. It was used, for instance, to study the acoustics of the renovated theater of the Philips Ontspanningsgebouw in 1935<sup>135</sup> and the new recording studio of the Vereeniging van Arbeiders Radio Amateurs (Workers' radio amateurs' association) (VARA) in the town of Hilversum in 1938.<sup>136</sup> That year, *Philips Technical Review* published articles on room acoustics as they related to reverberation,<sup>137</sup> speech intelligibility<sup>138</sup> and sound absorption.<sup>139</sup> Measuring equipment for studying the phenomenon of reverberation was developed by Willem Tak (1908–1984),<sup>140</sup> who published articles on the subject in March 1946<sup>141</sup> and December 1947.<sup>142</sup> Vermeulen mentioned Tak's reverberation meter, which was in regular use and didn't need much further development, in his December 14, 1946, proposal for an acoustics department research program.<sup>143</sup> Indeed, Tak's second article described a standalone configuration of measuring equipment that could be used to measure reverberation characteristics. Brief sonic impulses were played over a loudspeaker into the room whose reverberation was being measured. A microphone recorded the responses, which included the reverberation caused by the impulses, and the responses were then monitored on an oscilloscope.<sup>144</sup>

Vermeulen wrote in 1955 that while too long a reverberation time made speech unclear, too short a reverberation time made music sound "dry" and brittle. Many varieties of acoustic materials were available for shortening reverberation time and thereby improving clarity of speech. The opposite – lengthening reverberation time and, perhaps more importantly, making sound diffuse – could be achieved by electroacoustic means. Tests would later show that this could render a good theater suitable for concerts.<sup>145</sup>

Vermeulen had played the violin with the Philips Symphony Orchestra in the Philips Ontspanningsgebouw theater many times, and his desire to find a solution for the problem he pointed out was presumably partly based on his own practice as a musician. After the 1935 renovation, the room had excellent acoustics for theatrical productions, but as a concert hall it left a lot to be desired.<sup>146</sup> However, at the time of Tak's articles, one crucial technique for lengthening reverberation time electronically was still absent at Philips: that of recording sound on magnetic tape.



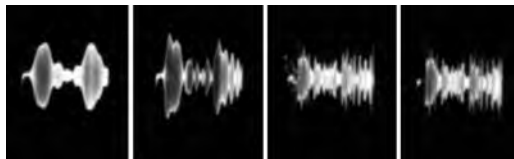
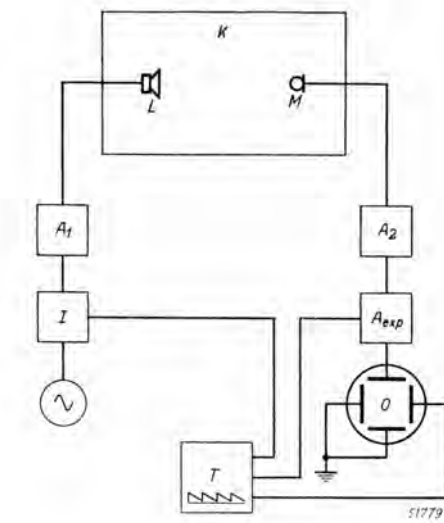

Fig. 1.37, 1.38 and 1.39: Measuring reverberation characteristics (1947). A sound impulse was produced by a loudspeaker (L) and picked up by a microphone (M). The photograph shows the tone generator GM2307 at top left and, under it, the cabinet that generated the envelope shapes of the sound impulses. Next to this cabinet was the oscilloscope that visualized the measurement. The oscillograms show the responses to impulses with durations of (from left) 0.12, 0.07, 0.035 and 0.02 seconds.

The imminent rise of magnetic tape recording technology heralded the end of the Philips-Miller project, and magnetic recording became the basis for the development of the Philips electronic reverberation system. In June 1952, *Philips Technical Review* ran its first article on magnetic tape recorders.<sup>147</sup> Friedrich Krones (1915–1986) had worked on magnetic recording techniques for Telefunken Austria in Vienna before becoming supervisor of Philips' Vienna laboratory in 1950. Between 1950 and 1953, he developed various magnetic tape recorders for broadcasting studios, including the Philips Studio Magnetophon 10039.<sup>148</sup> Philips in Eindhoven obtained a license to produce ferrite tape recorder heads around the same time.<sup>149</sup>

Vermeulen's research in the field of artificial reverberation was also related to ideas of Stokowski's. In Chapter 15 of *Music for All of Us*, entitled "Reflection and Absorption – Echo and Reverberation," the conductor had written:

In the future, it will be possible to build concert halls and studios for radio and recording that have variable acoustics. [...] In the future it will be possible to

pick up and amplify any zone of frequency, and prolong it by reverberation. [...] This will not be done by reflection, but by an electrical process.<sup>150</sup>



*Fig. 1.40: Philips 10028 magnetic tape recorder for broadcasting studios, 1950.*

heads. The output of the last head could be fed back to the recording head to prolong the series of repetitions. The outputs from the heads were routed to loudspeakers at various positions in the hall – on the ceiling, along the balcony railings, in the “dead” corners underneath

In the article “Stereo-Reverberation,” Vermeulen explained that stereophony could only reproduce the diffuse character of reverberant sound in a limited way. It could, however, be reconstructed, even through a single channel, if several loudspeakers distributed through the room were fed with different aleatory delays, repeated many times at decreasing volume levels.<sup>151</sup> Although Philips’ electronic reverberation system used magnetic recording technology, it did not use magnetic tape. Instead, it used a delay wheel. A magnetic recording surface was applied to the outer edge of the wheel. The sound of a musical performance on stage was picked up by microphones and recorded on the wheel from the recording head. Playback heads around the wheel then played the recorded signal back with different delay times. These delay times could be determined by moving the individual positions of the playback

the balconies. Every output was routed to several loudspeakers that were distributed around the hall in an arbitrary way, so that each delayed signal reached the listener’s ear from multiple directions and distances, thereby increasing the diffuseness of the overall audio impression. The intention was that the audience would never experience the sounds as coming from the speakers.<sup>152</sup>

A first experimental setup of the system was placed in the demonstration hall of the acoustics department at Philips Research



*Fig. 1.41: Philips 10030/11 recorder and 10031/11 amplifier, 1950.*

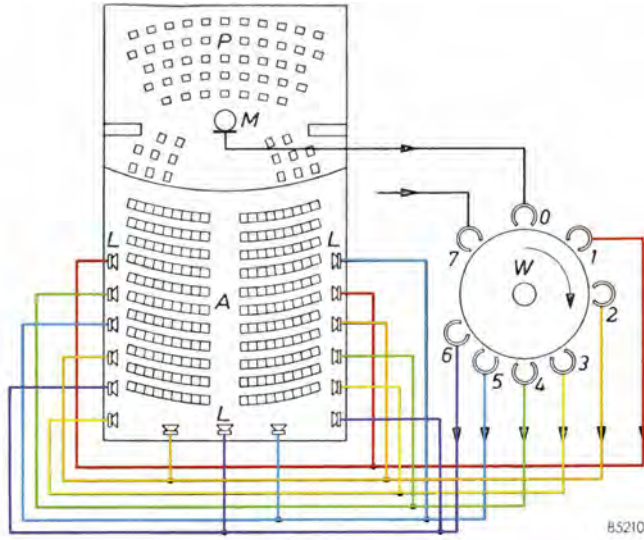

Fig. 1.42: Simplified diagram of the electronic reverberation system.

*P*: stage;  
*M*: microphone;  
*A*: auditorium;  
*W*: delay wheel;  
*0*: recording head;  
*1-6*: playback heads;  
*7*: erase head;  
*L*: loudspeakers.

The colors have been added to the lines by the author to emphasize the arbitrary routing of the delayed outputs to the various loudspeakers.

Laboratories, where it was publicly presented for the first time during the first International Congress on Acoustics in Delft in June 1953. Rather than installing the complex system in Delft, the company brought conference participants to Eindhoven by bus to witness the demonstration.<sup>153</sup>



Fig. 1.43: Demonstration hall of the Philips Research Laboratories acoustics department, 1948.



*Fig. 1.44: Prototype version of the electronic reverberation system installed in the Gebouw voor Kunsten en Wetenschappen in The Hague. Around the wheel were ten playback heads, of which six could be used simultaneously. The device in the upper right corner was used to create impulse-shaped envelopes. Sound impulses were used in the calibration of the delay times and playback levels of the reverberations.*

The system was demonstrated so successfully that in 1954, the company attempted to convert the acoustics of the Philips Ontspanningsgebouw theater to make them suitable for a concert hall. A similar prototype system was installed in the hall of the Gebouw voor Kunsten



*Fig. 1.45: Concert hall of the Gebouw voor Kunsten en Wetenschappen. Loudspeakers of the reverberation system are visible along the upper balcony.*

en Wetenschappen (Arts and sciences building) in The Hague the same year. The first public performance using the system was given there on November 30, 1954, by the The Hague Philharmonic, with a more pronounced demonstration of the system's capabilities after the concert. The audience response was positive, and the orchestra members and soloists consciously and clearly experienced an improvement in the "playability" of the hall.<sup>154</sup>

After the experimental phase of development at Philips Research Laboratories ended, the system became commercially available through Philips' ELA division under the serial number EL6910. It now had four playback heads instead of six. The system was sold to venues including the Teatro alla Scala in Milan, where the conductor Herbert von Karajan

(1908–1989) worked with ELA engineer D. Kleis during calibration. The reverberation system was inaugurated in a performance of Mozart's opera *Die Zauberflöte* under the direction of Von Karajan on December 7, 1955.<sup>155</sup> When Von Karajan was asked in 1958 to conduct a per-

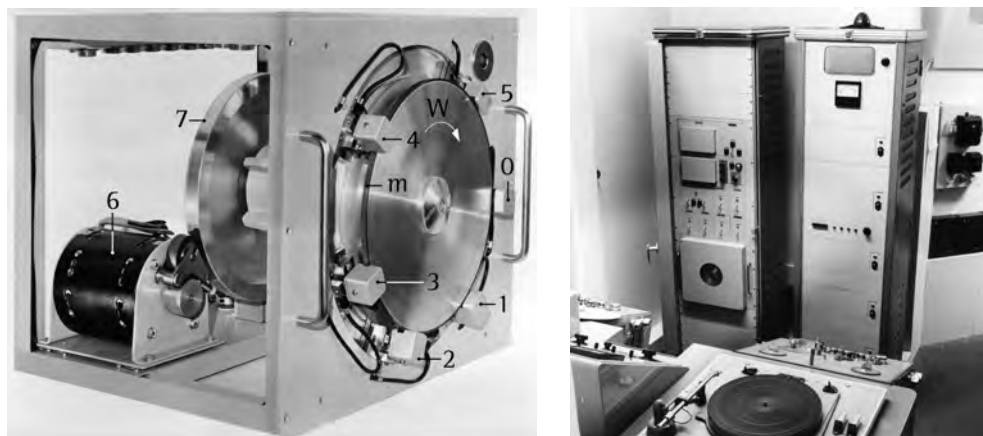

Fig. 1.46 and 1.47: At left, the assembly with delay wheel (*w*) that was part of the EL6910 stereo reverb system. *M* is the recordable surface; *O* the recording head; 1, 2, 3 and 4 the playback heads; and 5 the erase head. 6 is the motor and 7 the flywheel. The maximum delay for playback head 4 was 0.25 or 0.5 seconds, depending on the chosen speed of the wheel. There was an air gap between the heads and the recordable surface of the wheel of approximately 20 microns. The lack of mechanical contact between the heads and the wheel made the system's lifespan practically unlimited. At right, the complete EL6910 installation (the rack in the back on the left) in the control room of the Palais de Chaillot in Paris.

formance in the grand auditorium at the World's Fair in Brussels, he accepted the invitation on the condition that a similar system be installed there. His request was granted.<sup>156</sup>

A very similar type of equipment was developed a few years later by Telefunken. It was presented in the *Gravesaner Blätter* in 1958<sup>157</sup> without any reference to Vermeulen's work at Philips. In August 1965, Abbey Road Studios in London installed what it called a "system for ambiophony" to lengthen the decay time of reverberation in Studio One. The system was the brainchild of recording engineer Gilbert F. Dutton, who, according to the book *Recording the Beatles*, had turned to a "then-new technology known as delay drum." The drum had six playback heads, each connected to a set of sixteen loudspeakers distributed around the walls and ceiling of Studio One. According to the engineer Brian Gibson, "Ambiophony was another example of EMI pioneering new ideas."<sup>158</sup> Dutton's system, however, was clearly an expanded version of Philips' system, and even the terminology was borrowed from Vermeulen.

## The Gravesano Music and Electroacoustics Conference

The conductor Hermann Scherchen (1891–1966), a confirmed communist, left Germany in 1933 for political reasons. After staying in various countries, Scherchen bought a house and a piece of land in Gravesano, Switzerland, towards the end of 1953. Construction of the Centro Sperimentale Electroacustico (Center for experimental electroacoustics) began there the next





Fig. 1.48, 1.49 and 1.50: Telefunken's time delay unit (upper and lower left) and EMI's delay drum for ambiophonic sound (right).

year, and the first studio was ready within three months. The studio had a sloped ceiling and five walls instead of the usual four so as to exclude parallel surfaces. Scherchen believed any particular space "gibt Kleidung" (dresses up) and gives "Gesichtsfarbe" (complexion) to any music produced in it and there was therefore no such thing as an ideal space, only exceptionally beautiful individual spatial circumstances. First of all, Scherchen wanted to build a studio that canceled reverberation out completely. He did indeed manage to reduce reverberation time to 0.4 seconds. Using directional microphones brought effective reverberation time down further, to under 0.25 seconds. Second, Scherchen wanted to experiment with adding very specific types of reverberation to specific types of music by acoustic and electroacoustic means. Besides the studio, he built four reverberation chambers with very different frequency characteristics and reverberation times. The longest reverberation time he could create using these chambers was over seven seconds. By 1956, the studio was using a range of equipment to create artificial reverberation, such as various modified tape recorders and spring reverbs. Scherchen was convinced that the technological specialization of phonograph records, radio broadcasts, cinema and television had led to the beginning of a synthesis of electroacoustics, "Schallwissenschaft" (acoustics) and artistic design. Furthering this had been his goal and motivation for building his experimental electroacoustic center.<sup>159</sup> One can easily see how Scherchen's interest in artificial reverberation techniques related to Vermeulen's research in this area.

In August 1954, just eight days after the studio complex in Gravesano was ready, Scherchen hosted the international Musik und Elektroakustik conference there.<sup>160</sup> Speakers

included Vermeulen; the German physicist Werner Meyer-Eppler<sup>161</sup> (1913–1960); Maurice Martenot (1898–1980), the inventor of the ondes Martenot; the composer and traultonium<sup>162</sup> player Oskar Sala (1910–2002); Friedrich Trautwein (1888–1956), the traultonium's inventor; the composer Pierre Schaeffer (1910–1995); and his technician, Jacques Poullin. A Philips electronic reverberation system, though still in its experimental phase, was set up in Gravesano for the occasion. To demonstrate Vermeulen's achievements, a recording of the final chorus of Johann Sebastian Bach's *Matthäus Passion* was played through the system's loudspeakers with different time delays.<sup>163</sup>

The proceedings of the conference were published in July 1955 in the book *Musik – Raumgestaltung – Elektroakustik* (Music – Space design – Electroacoustics),<sup>164</sup> edited by Meyer-Eppler. The articles were grouped into four sections: 1) The conversion of music into electronic sound formations, 2) Sound carriers, 3) Electronic musical instruments – Concrete and electronic music, and 4) Science – Technique – Art. In his contribution to the proceedings, Vermeulen pointed out that despite all the technical advances, it was still possible to distinguish sound reproduced by loudspeakers from sound from an original source. Vermeulen considered this the key problem of electroacoustics. He agreed that increasing the frequency range to 12 kHz, 20 kHz or even into the ultrasonic might be necessary<sup>165</sup> but doubted whether that alone would solve the problem.<sup>166</sup> He considered stereo reproduction part of the solution, but this still involved the listener being in a much smaller space than the one where the performance had been recorded. Therefore, he said, the next step was to mimic a concert hall's proportions in the listening room.<sup>167</sup> Although there was not yet conclusive proof, Vermeulen believed diffuseness played an even more important role here than reverberation.<sup>168</sup> The statement brings to mind Vermeulen's first loudspeaker design. Although intended for monophonic sound reproduction, it was in essence ambiophonic. After all, no direct speaker sound reached the listener's ears: the sound was bounced back by the large front element first and then diffused from the circular opening around it (see fig. 1.3 and 1.4, 19).



*Fig. 1.51 and 1.52: Experimental setup of the Philips reverberation system at the 1954 Gravesano music and electroacoustics conference.*



## Electronic Musical Instruments for the Fair of Science

On May 16, 1945, Vermeulen met with P. R. Dijksterhuis,<sup>169</sup> head of the Philips Apparatenfabriek (machine works), who had come up with the idea for an electronic piano back in the mid-1930s. Vermeulen proposed producing a polyphonic musical instrument much smaller than a grand piano, which would allow for the individual practice of music on a large scale.<sup>170</sup> Subsequently, in a report on June 20, 1945, he suggested devising new, modern musical instruments that could be used at home as well as in the concert hall. He referred specifically to further development of an old instrument, the clavichord, saying this would be achievable using modern electroacoustics techniques. This instrument, now called the Philichord,<sup>171</sup> Vermeulen discussed extensively with Holst on December 17, 1945.<sup>172</sup> About a year later, the Philichord was mentioned again in a proposal for an acoustics department research program (also see Chapter 2, 38–40). The Philichord would be a new, cheap musical instrument that would use a loudspeaker to radiate its sound and would possess different, preferably better, qualities to existing instruments. Vermeulen expected that the playing of music at home would become popular again, especially among the increasingly emancipated working class, and thus the need would arise for an instrument with a more beautiful sound than the harmonica, one that would be suitable for classical music, cheaper and smaller than a piano, and easier to play than a violin.<sup>173</sup> The last reference to the Philichord occurred on June 18, 1947, when it, the Philiolist (the loudspeaker violin of Chapter 1, 36–7) and the Philibassist (presumably the bass instrument Stokowski had asked for) were on Vermeulen's agenda of a meeting with Holst's successors Herre Rinia and Hendrik Casimir.<sup>174</sup> The Philichord had strings that were stretched close to a metal plate. The strings constituted one electrode of a capacitor, the metal plate above the strings being the other electrode. The capacitor was incorporated in an amplifier circuit in exactly the same way as a condenser microphone (also see fig. 1.56). One could play this instrument polyphonically, like a normal clavichord, and produce a typical clavichord vibrato. Loudness was controlled by means of the strength of the attack and an electronic pedal.



*Fig. 1.53 and 1.54: The new wing of Philips Research Laboratories and the Kermis der Wetenschap of 2 July 1955.*

More electronic musical instruments were developed for the Kermis der Wetenschap (Fair of science), held on July 2, 1955, to celebrate the opening of a new wing of the Philips Research Laboratories buildings and the laboratories' fortieth anniversary the previous year.

Many of the attractions at the fair, which had a scientific flavor, were developed by the laboratories' various departments. Vermeulen's acoustics department produced an ensemble of electronic musical instruments and played a humorous version of Vittorio Monti's famous Hungarian folk dance *Czárdás* on them.<sup>175</sup> Each of the instruments had its own amplifier and loudspeaker. They were designed to cover the entire audible frequency range together, and they played loudly enough to be heard everywhere in the large hall over the noise of the fair. Besides the polyphonic Philicord, the melodic section consisted of four monophonic instruments. The soprano and tenor parts were played on two multivibrators, whose pitch was determined with variable resistors. The alto part was played using the frequency control of a tone generator. The bass part was played on a low-frequency RC oscillator. The rhythm section featured two large condenser microphones whose membranes (with diameters of fifteen and twenty cm respectively) were played like drum skins with the fingers. There were also a gated noise generator, used in place of cymbals, and an electronic imitation of a Turkish drum. The circuit design for this drum consisted of a capacitor that was discharged over an LC ring; the connected amplifier was coupled to reduce damping. According to an article in *Philips Technical Review*, the public found it especially fascinating that the orchestra could produce such loudness without any extra effort on the part of its members.<sup>176</sup> All these instruments were used in the following year to produce Henk Badings' electronic ballet music *Kain en Abel*.



*Fig. 1.55: Members of the Philips Research Laboratories acoustics department performing Vittorio Monti's "Czárdás" with self-built electronic instruments at the Festival of Science on July 2, 1955. From left: Jan de Bruyn on electronic drums, Dick Raaijmakers on Philicord, Roelof Vermeulen on unidentified instrument, Cees Wansdronk on multivibrator.*



gebouw Orchestra under the direction of Eduard van Beinum. It was followed by Amsterdam performances of many other of Badings' works, such as the Second Symphony in 1933 under Van Beinum, the Third Symphony under Mengelberg in 1935, and the Second Violin Concerto in 1938. No other Dutch composer had captured so much attention in such a short time, both nationally and internationally. Many of his works were published in Germany and Austria by Schott and Universal.<sup>177</sup> Badings worked as a scientific assistant at Technische Hogeschool Delft until he decided to dedicate his life to music in 1937.

Badings' music was influenced by the school of Max Reger (1873–1916) and Paul Hindemith (1895–1963).<sup>178</sup> Badings shared Hindemith's aversion to the twelve-tone music of Arnold Schoenberg (1874–1951). In 1936, he wrote a book about contemporary music in the Netherlands in which he clearly formulated his opinions about the new trends. He wrote of music by composers "whose art consists only of bringing together 'new' sounds,"<sup>179</sup> of "too much tribute paid to the demolishers of the already unstable building of monotony,"<sup>180</sup> and of the "uninhabitable constructions of the revolution,"<sup>181</sup> while expressing his appreciation for music that was "untainted by the twelve-tone technique."<sup>182</sup>

Badings had always had an explicit interest in acoustics, which was presumably the reason for his eventual attraction to electronic music. He said he had speculated about using electronic sound generation for musical purposes as a student in Delft, hence before 1931.<sup>183</sup>

His first electronic piece was part of a twenty-minute radio play based on William Butler Yeats' (1865–1939) 1892 verse drama *The Countess Cathleen*. The work was commissioned and broadcast in December 1952 by the Katholieke Radio Omroep (Catholic radio broadcasting company) (KRO). According to Badings, "concrete sounds and the sounds of musical instruments were combined in an electronically processed composition. For instance, in a six-part fugue, only two parts were 'played,' and the others were added after electronic transformation."<sup>184</sup>

The second Dutch composition to include electronic sounds, also by Badings, was the 54-minute radiophonic opera *Orestes* of July 1954. The libretto was written by Jan Starink (1927–2014), who had begun writing KRO radio plays in 1952. The NRU commissioned Badings specifically to take advantage of the possibilities afforded by current radiophonic techniques. Badings, as he himself said, tried to integrate technological effects in the most organic possible way, using them not for their own sake but for the sake of their expressive value. When, in the most striking effect, he created a choir of Erinyes (Greek goddesses of vengeance) by doubling the speed of a recording of a male choir, he did so in the first place because he wanted "to 'dehumanize' the voices of the Erinyes."<sup>185</sup> Pure electronic sounds produced with generators occurred at only a few points in the score. Noise sounds were added in "Prologue" (at number 4 in the printed score) and at the transition from "Fantasmagoria" to "Episode." Synthetic sounds from a sawtooth generator were used only in "Fantasmagoria" (at numbers 35 and 39 in the printed score). Most "radiophonic effects" (the term Badings preferred to "electronic sounds"), however, did not come from electronic sources but were obtained through

the modification of recorded acoustic sounds with tape recorders, for instance, through changing the playback speed or reversing the playback direction. All others were obtained through tape splicing.<sup>186</sup>



Fig. 1.58: Production of the radiophonic opera "Orestes" at the AVRO studio with Philips 10040 tape recorders. From left: Theo van Woerkom (seated), Luuk Ludolf, Arie Brandon, Henk Badings.

The NRU nominated *Orestes* for the Prix Italia – an international competition for radio programs founded by Radio Audizioni Italia (RAI) in 1948 – and it won before even being broadcast in the Netherlands. Six months after the NRU's production of *Orestes*, the BBC repeated it, using the same musicians and technicians.<sup>187</sup> After winning the prize, *Orestes* was broadcast by more than nine hundred radio stations worldwide.<sup>188</sup>

### **Henk Badings' *Kain en Abel* and the Studio Equipment in Room 306**

"If the music center is to fully achieve its goal, that of presenting music to the audience in a lively new form, then composers in particular must be involved through the giving of commissions."<sup>189</sup> Although Vermeulen wrote these words in June 1945, it was not until 1956 that the first composer became involved in his "canned music" research project. That composer

was Henk Badings. According to Dick Raaijmakers (1930–2013), who was working in the acoustics department of Philips Research Laboratories at the time of the production of *Kain en Abel*, it was probably Badings' background as a mining engineer that enabled him to speak Vermeulen's scientific language. Badings' conventional musical style was also likely suitable, in Vermeulen's eyes, for evaluative tests like those affiliated with the "Multiplication of Concerts" project.<sup>190</sup> One should also not forget that Vermeulen had to account for his research activities to the board of directors of a commercial company. And last but not least, Badings' *Orestes* had won the Prix Italia less than two years before the production of *Kain en Abel*.

In 1956, the Nederlands Ballet commissioned Badings to compose a piece of music for the Holland Festival, and he wanted to use electronic sounds in it. Walter Maas' (1909–1992) Gaudeamus foundation put Badings in touch with Vermeulen, who arranged for Badings to produce an entire electronic work at Philips Research Laboratories. After an exploratory visit to Eindhoven, during which the acoustics department demonstrated the capabilities of its electronic musical instruments, Badings wrote the score for *Kain en Abel*. It consists largely of traditionally notated parts, to be played on instruments such as the Philicord (electronic clavichord) and the multivibrator or spliced together from individually recorded electronic sounds. Some parts were recorded by Badings at home on his piano.<sup>191</sup> During the production of *Kain en Abel*, Badings received technical assistance from Vermeulen's staff member Jan de Bruyn (1926–1974) and NRU technician Arie Brandon, who had played a key role in the production of Badings' *Orestes* at the NRU in 1954.

To facilitate the technical execution of *Kain en Abel*, an electronic music studio was set up exclusively for the production in room 306 of the acoustics department. Although Vermeulen intended the studio to be temporary at first, the equipment was reinstalled in September 1957 and remained in place until November 1960. Room 306 became the birthplace of electronic concert music by Badings and Raaijmakers, popular electronic music by Raaijmakers and Tom Dissevelt, music by Badings and Ton de Leeuw that combined traditional



*Fig. 1.59: Henk Badings and Roelof Vermeulen in room 306 at Philips Research Laboratories during the production of "Kain en Abel," April 1956. In the picture are two Wandel & Goltermann third-octave bandpass filters with complementary series of bandpass ranges (1); a Philips GM2307 sine wave oscillator (2); a custom-built Philips octave bandpass filter (3); a Philips GM5653 oscilloscope (4); and the amplifier of a Philips 10039 tape recorder (5).*



instruments with taped electronic sounds, and electronic film scores by Badings and Raaijmakers.

Fig. 1.60: The first page of Badings' manuscript for "Kain en Abel" (1956).



Several months after the production of *Kain en Abel*, De Bruyn wrote an extensive report giving detailed information about the equipment, the methods used and the way the work was presented to the audience. According to the report, the following types of equipment and materials were used:

- Technical devices normally used for electronic measurement (oscillators, noise generator, filters).
- Devices developed at Philips Research Laboratories to serve as musical instruments (which were more or less identical to the instruments made for the Fair of Science in July 1955).
- Tape recorders.
- Recorded musical instruments (a grand piano, cymbals, a triangle, a bell).
- Additional devices for further transforming the primary sounds, such as the Philips EL6910 electronic reverberation equipment, an envelope generator and a ring modulator.<sup>192</sup>

The oscillators used were Philips' GM2307 and GM2315, which could only produce sine waves. Schouten's optical siren (see Chapter 1, 33–5) was additionally used, since unlike the sine wave generators, it could produce a wide variety of timbres. When sounds from the optical siren with different timbres but identical pitch were sequenced by means of tape splicing, Badings referred to the result as a "Klangfarbenmelodie" (sound-color melody).<sup>193</sup>

De Bruyn mentions three types of filters, two of which were custom-built by Philips. One of these, called a "characteristics molder," could amplify or attenuate the frequency range of a sound at twelve different points within a range of 6 dB. The other was a filter that could limit the bandwidth of a sound to one or several octaves.<sup>194</sup> Filters of the third type were third-octave bandpass filters made by Wandel & Goltermann. In later years, similar ones were used at the electronic music studio in Cologne.<sup>195</sup> These filters had complementary series of band-pass ranges. When noise was passed through them, the bandwidth of the filtered noise was so narrow that it sounded pitch-like. By sequencing various filtered noises, one could create what Badings called a "noise melody."<sup>196</sup>

De Bruyn's report also mentions the use of three portable Viennese professional mono tape recorders, type 10039, with a tape speed of 76.2 cm/sec.<sup>197</sup> The combining of acoustic layers was usually effected through playing two or more tape recorders simultaneously, mixing the respective outputs, and capturing the resultant mix on a separate machine. Each individual layer was created to a speci-



*Fig. 1.61: Henk Badings playing the multivibrator (see Chapter 2, 62–3).*



*Fig. 1.62: Henk Badings playing the Philicord. Behind the score is an electronic drum, which was played with the fingers (see Chapter 2, 62–3).*

fied time length, using the most prominent voice in the work as a reference. The next step was to make a number of tape copies of the main voice, one for each layer. On the back of each copy, pencil marks were made at the points where the starting points of the secondary voices were located with respect to the main voice. Then the copies were electronically erased and the sounds belonging to the secondary voices spliced in at the pencil marks. For every length of tape spliced in, an equivalent amount was removed, so that the total length of every copy remained the same. When the tapes were played synchronously, they constituted the complete work.

De Bruyn describes how the beginning of each sound layer was spliced after a leader tape that contained spoken sequential reference numbers, 1 through 25, each followed by an audible click. By slightly manipulating the tape speeds of the individual machines by hand, one could get

them into sync before the actual music started. However, since the machines' speeds would eventually drift, acoustic layers synchronized in this fashion could not exceed a duration of three minutes. Therefore, various shorter synchronizations had to be performed and the results spliced together later.<sup>198</sup>



*Fig. 1.63: Room 307 at Philips Research Laboratories, with two Philips 10040 stereo tape recorders and two Philips EL6910 electronic stereo reverberation systems (not visible). From left: Roelof Vermeulen, Henk Badings, NRU technician Arie Brandon, Jan de Bruyn. Visible in the lower right corner are a loudspeaker for low frequencies and a smaller one for high frequencies, which pointed away from the listeners to produce nondirectional ambiophonic sound. Between the two tape recorders are interchangeable head blocks with different track configurations.*

Next to the electronic music studio was room 307, which contained two EL6910 electronic reverberation systems and two tape machines, type 10040: the so-called NRU decks (see fig. 1.63). These recorders were special Philips Research Laboratories stereo versions suitable for recording and playing back the stereophonic effects created with the EL6910 reverberation units. Room 307 had a large patch bay with multiple audio connections to the acoustics department's demon-

stration hall, where the possibilities afforded by stereo reproduction and ambiophonics were regularly demonstrated, and through permanent telephone lines to the Philips Ontspanningsgebouw, so that concerts could be recorded in artificial-head stereo.<sup>199</sup> In his report, De Bruyn describes how the reverberation system was used to add an acoustic quality to *Kain en Abel's* otherwise dry electronic sound material, and how it was used with excessive feedback settings to create specific sound effects.

Production of *Kain en Abel* was completed on April 20, 1956.<sup>200</sup> According to De Bruyn, the parts of the written score were divided into two groups just before technical execution began. The final master tape was recorded on a stereo machine, with one group of sounds in the left channel and the other in the right. As mentioned earlier, Vermeulen had concluded from his research that two spatial effects were essential to the complete enjoyment of music: differentiation between the directions of musical instrument sounds, which could be simulated by means of stereophony, and diffuseness of reverberant sound, which could be simulated through ambiophony. He believed ambiophony was the more essential of the two (see Chapter 2, 53–9).<sup>201</sup> The plan was to play one channel of *Kain en Abel* through loudspeakers on the stage, projecting the sound directly at the audience, while the other was “diffused” through the reverberation system and the speakers connected to it, thereby surrounding the audience.

The first performance of *Kain en Abel* took place in the hall of the Gebouw voor Kunsten en Wetenschappen, which had the required reverberation system permanently installed.<sup>202</sup> This first performance was not part of the Holland Festival, and it is unclear whether the music was presented with or without the ballet for which it was composed. The Holland Festival performances took place on June 22 and July 9, 1956, in the Koninklijke Schouwburg (Royal theater) in The Hague and the Stadsschouwburg (City theater) in Amsterdam.<sup>203</sup> Since neither had a reverberation system installed, the second channel of the stereo tape was played through ten Philips 9710M loudspeakers mounted on panels. The panels were placed so as to reproduce the sound as diffusely as possible.<sup>204</sup>

In the conclusion of his report, De Bruyn wrote that although failings had been present in various aspects of the work, in general it could be said that the production had been successful within the context of its intentions. At certain points, it had proved impossible to follow the score in every detail, since the work had to be finished in seventeen days.<sup>205</sup>

On May 30, 1956, less than a month before the Holland Festival premiere of *Kain en Abel*, the first electronic music concert in Germany with multichannel sound reproduction had taken place in the large broadcasting studio of Westdeutscher Rundfunk in Cologne, including four-channel electronic compositions such as *Klangfiguren II* (1955–1956) by Gottfried Michael Koenig (\*1926) and *Gesang der Jünglinge* (1955–1956) by Karlheinz Stockhausen (1928–2007).<sup>206</sup> In contrast to the hastily realized *Kain en Abel*, the Koenig and Stockhausen works had taken more than a year to produce and were deeply rooted in serial composition techniques.

In an article about electronic music in the magazine *Mens en Melodie*, the composer and music critic Wouter Paap (1908–1981) extensively discussed *Kain en Abel*, comparing it to the Cologne school works of Stockhausen and others. According to Paap, Badings had gone at least as far in the use of pure electronic sound effects as his German and Belgian colleagues and certainly equaled them when it came to ingenuity and technical skill. But he differed from the electronic “revolutionaries” in an essential way: he maintained clear ties to traditional musical language. Whereas Stockhausen and his ilk made electronic music in the abstract realm, Badings had used it to express a human psychological process: the conflict between the brothers Cain and Abel, which he saw as a battle between the pure and the dark, the constructive and the destructive. Paap suggested Badings might have applied characteristically nonmusical electronic sounds at exactly those points in the score where the destructive elements of the tragedy of Cain and Abel were in play (such as in the murder dance) in order to criticize the electronic extravagances of the Cologne school composers.<sup>207</sup>

### ***Variations électroniques* and Philips’ Commercial Animation Films**

The studio in room 306 was dismantled after the production of *Kain en Abel*. Nevertheless, Badings continued to compose electronic music, including scores for the television play *De Nacht van Morgen* (The night of tomorrow) in April 1956 for the Algemene Vereniging Radio Omroep (General radio broadcasting association) (AVRO) and for the film *De Vliegende Hollander* (The Flying Dutchman), commissioned by Cinetone film studios in Amsterdam and produced in June 1957 at a studio of the Omroepvereniging VARA (VARA broadcasting association).<sup>208</sup> Badings next produced a work at Philips Research Laboratories in August 1957. It was *Variations électroniques*, an electronic composition for an animated film.

The production of the animated short *Variations électroniques* was, in a way, part of a tradition. Before World War II, Philips had used animated films to advertise its products. General advertising director Sies Numann had met the Hungarian animator and film producer George Pal (1908–1980) in Paris in 1934, while Pal was working on the Philips animated film *Radio Valve Revolution*. Pal then moved to Eindhoven after Philips invited him to make the promotional film *The Ship of the Ether*. This led to the founding of the Pal Studio, one of the largest specialized film studios of its kind in those years, in Eindhoven.<sup>209</sup> It was dedicated to stop-motion animation using dolls; Pal called his films “puppets.”<sup>210</sup> He worked closely with the composers of the music for his films, which was recorded in a Philips studio on a Philips-Miller system.<sup>211</sup> Pal’s intensive collaboration with Philips ended when he suddenly moved to the United States in 1939, never to return. His Eindhoven studio closed at the end of March 1940.<sup>212</sup>

After Pal left the Netherlands, the production of stop-motion animation using puppets resumed in Amsterdam in 1942, when Joop Geesink (1913–1984) and Marten Toonder’s (1912–

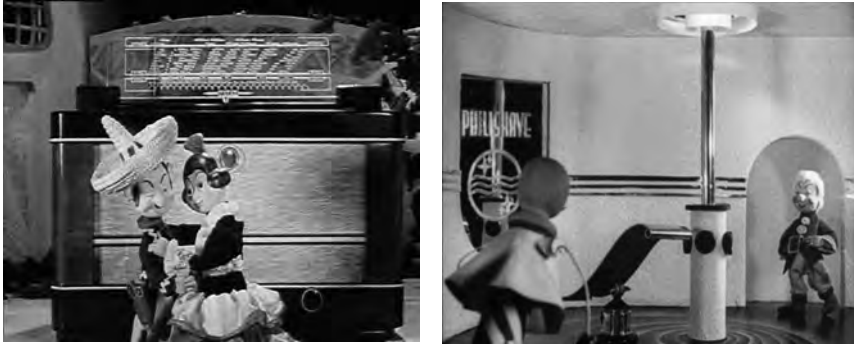

Fig. 1.64 and 1.65: Two figures dancing in front of a Philips Serenade radio receiver in "Serenata Nocturna" (left) and a gnome entering a futuristic barbershop to receive an electric shave from a robot in "Phi-garo in het woud."

2005) Geesink-Toonder Studio made *Serenata Nocturna* as a commercial for Philips radio receivers and *Phi-garo in het woud* (Phi-garo in the woods, 1943) for Philishave electric shavers.<sup>213</sup>

After the production of *Phi-garo in het woud*, Geesink-Toonder split into Toonder Studios, which specialized in drawn animation, and Geesink's Dollywood Studios, which specialized in stop-motion animation. Both went on to receive commissions from Philips. At Toonder Studios, the famous comic strip figures Tom Puss and Oliver B. Bumble were cast in the commercials *The Haunted Castle* (1948), for Philips lamps, and *The Magic Music* (1948) and *Dreamland* (1949), for Philips radios.<sup>214</sup>



Fig. 1.66, 1.67 and 1.68: Stills from the last scene of "The Haunted Castle" (1948).

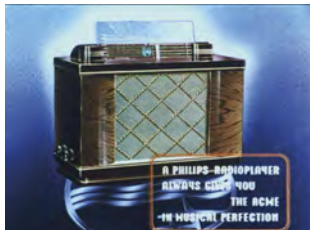

Fig. 1.69, 1.70 and 1.71: Stills from the final scenes of "The Magic Music" (1948).

Although Toonder Studios' next three films<sup>215</sup> were not made to advertise Philips products, they served the company's needs in a different way: they were made to become part of its experimental television programming.<sup>216</sup> After Philips entered the radio business in the 1920s, its activities gradually came to include every area of the industry except broadcasting. After all, it could sell its products in an already existing market. However, with television the situation was completely different. When the company started to develop equipment for television broadcasting and reception, no associated market existed in the Netherlands at all. Therefore, Philips itself began making experimental television broadcasts in 1935, and continued doing so after a ten-year hiatus with a new series that started on March 18, 1948. The Philips Experimentele Televisie (PhET) broadcasts aired three nights a week, with news, entertainment, sports, plays, children's programs, instructional shows and so on. The programs were recorded in a small studio at Philips Research Laboratories and only reached the Eindhoven area, where the audience consisted mainly of Philips employees, to whom the company had loaned television sets.<sup>217</sup> By the time the Dutch broadcasting companies finally took over with their national television programming on October 2, 1951, PhET had broadcast a total of 264 programs.<sup>218</sup>

All the aforementioned films by PaI, Toonder and Geesink used fairly conventional musical scores. In fact, the example of Lou Lichtveld's musical experiment for Joris Ivens' 1931 film *Philips Radio* (see Chapter 1, 22–5) had not been followed since. But that changed in 1953, when director Han van Gelder (1923–2012) made the tabletop animation film *The Conquered Planet* at Toonder Studios. The film tells the story of spaceship S.M. 3, which has crash-landed; the surviving crew are unable to respond to repeated calls from earth: "S.M. 3, report, please." The film ends with an image of a telex machine typing, "Though the first space trip met with disaster, sufficient experience has now been gathered to encourage mankind never to give up their efforts to conquer space."<sup>219</sup>

Instead of the obvious dramatic music, the soundtrack of *The Conquered Planet* contains sparse layers of sound effects and abstract pitch sequences, made by cameraman John van der Meulen on Toonder Studios' newly purchased sound system. The system included Philips tape machines that could raise or lower the playback speed of recorded sounds and play them in reverse.<sup>220</sup> Not only was Van der Meulen's electronic soundtrack made four years earlier than Badings' first electronic film score, it was also more experimental, in the sense that it relied less on traditional rhythm and melody and tended more towards "sound composition."<sup>221</sup> *The Conquered Planet* was initially made as a noncommissioned film. It then attracted the attention of Numann, who considered both the use of Philips equipment in the production of the music and the theme of space travel good reasons for Philips to buy the film.<sup>222</sup> The structure of the final film indicates that the first ninety seconds were added only after Philips had decided to buy it. The titles at the beginning state that the film has been "sponsored by Philips, whose telecommunication spans the earth and will eventually connect the planets"; these are followed by images of reporters with Philips microphones, a Philips radio dial, and



Philips-built broadcast installations. Toonder Studios' original title sequence appears only after this section.



Fig. 1.72, 1.73 and 1.74: Stills from "The Conquered Planet" (1953), with crashed spaceship (center) and dying astronaut (right).



Fig. 1.75, 1.76 and 1.77: Stills from the Philips introduction added to "The Conquered Planet" (1953), with Philips microphone and radio dial (center) and high-voltage broadcasting installation (right).



Fig. 1.78, 1.79, 1.80, 1.81, 1.82 and 1.83: Stills from the animated short "Variations électroniques." (The name Jan de Bruin should have been spelled Jan de Bruyn.) (The red color cast is caused by the aging process of the original film.)



Just as with *The Conquered Planet*, work on the animated short *Variations électroniques* started without any connection to Philips' products. The musical score shows that it was carefully written to fit a storyboard made in June 1957 by art director Emile Brumsteede (1911–1962) and producer Gerard J. Raucamp for an animated film that was to be made by Carillon Films.<sup>223</sup> Although the music was produced exactly according to Badings' score, the original storyboard remained unused. The music was shortened from ten to seven minutes and formed the basis for a completely different script that turned the film into a commercial for Philips television sets.

While Badings was working on the music for *Variations électroniques* at Philips Research in August 1957, the studio was not installed in room 306. Instead, the equipment that had been used for *Kaïn en Abel* was set up in a room next to the acoustics department's demonstration hall, with the addition of an ondes Martenot electronic keyboard instrument. Badings now had two assistants: Jan de Bruyn and Dick Raaijmakers. Shortly before the making of *Variations électroniques*, Vermeulen had sent Raaijmakers to Paris to order an ondes Martenot and personally receive playing instructions from Maurice Martenot. It was Raaijmakers' first step into the world of electronic music, and he would remain Badings' assistant until the studio closed in Eindhoven and moved to Utrecht in November 1960. During the production of

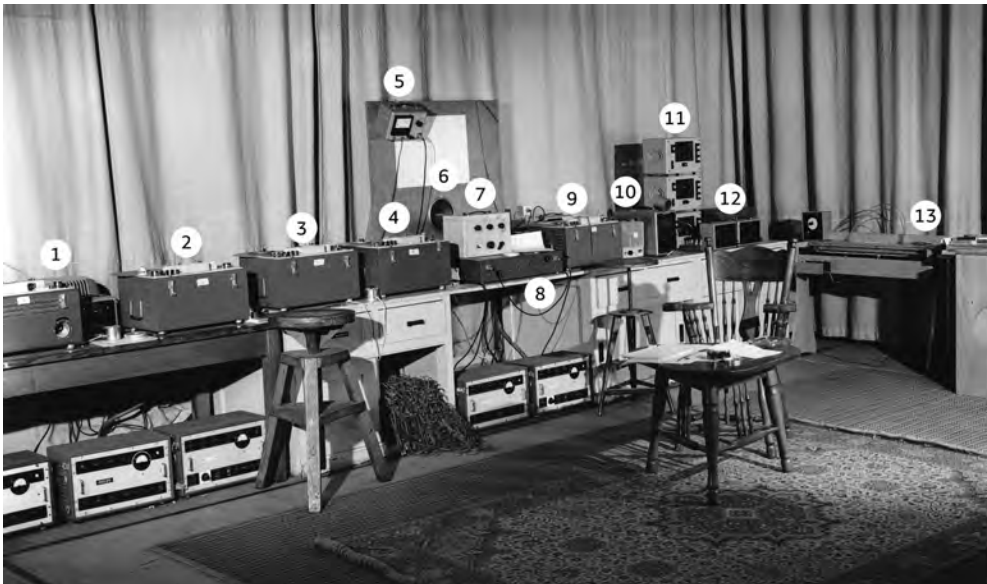

Fig. 1.84: Equipment installed in the room next to the acoustics department demonstration hall for production of "Variations électroniques": Philips EL3509 tape recorder (1); Philips 10039 tape recorder with power amplifier and Philips GM2315 sine wave generator to enable variable recording and playback speeds (2); Philips 10039 tape recorders (3, 4, 9); Philips AC millivolt meter (5); Philips 9710M loudspeaker (6); Philips GM5659 oscilloscope (10); three Wandel & Goltermann third-octave filters (11); two Philips GM2315 sine wave generators (12); ondes Martenot (13).

*Variations électroniques*, De Bruyn communicated to Raaijmakers the knowledge he had gained while working on *Kain en Abel*.<sup>224</sup> De Bruyn was transferred to the ELA division immediately afterward and became Edgard Varèse's assistant during the production of the music for the Philips Pavilion at the 1958 World's Fair.

## **The Electronic Popular Music of Dick Raaijmakers, aka Kid Baltan**

Dick Raaijmakers' path to Philips Research Laboratories was, as he himself has often remarked, that of a sleepwalker. He had already developed a great interest in music and radio technology during the Second World War, though initially as completely separate areas. He sang in the church choir, took piano lessons and soon began composing piano pieces. Meanwhile, he built a number of primitive radios and amplifiers using outdated, hard-to-find components. For Raaijmakers, the feeling of liberty he felt after the war ended could not have been better illustrated than by the sound of the first experimental stereo radio broadcast on June 15, 1946, by Stichting Radio Nederland (Radio Netherlands foundation) (see Chapter 1. 28–33). The fifteen-year-old Raaijmakers dragged an extra radio set into the living room to hear the experiment with his parents. But his radio hobby was relegated to the sidelines in 1947, when he went to study piano at the conservatory in Tilburg and then in The Hague. During the final year of his studies, however, he developed the desire to find a profession that combined music and technology. How exactly this might be accomplished remained vague in his mind. At that time, electronic music was in its infancy, and Raaijmakers was unaware of its existence. Instead, he made plans in the direction of radio and phonograph recording technology.<sup>225</sup>

To acquire technical experience, in 1954 he took a job on the radio and television assembly line in the Philips factory in Eindhoven and obtained a diploma in radio engineering from the Nederlandsche Radio Genootschap (Netherlands radio society). In 1955, he made an extraordinary move to Philips Research Laboratories, where he found work in Vermeulen's acoustics department. Soon afterwards, the studio for the production of *Kain en Abel* was installed in room 306. On hearing the sounds that emanated from under the door, Raaijmakers became greatly intrigued by this new phenomenon. At that time, he was working mainly on the maintenance of electronic reverberation installations (see Chapter 2, 50–3).<sup>226</sup>

After the production of Badings' "high art" *Kain en Abel* ballet music, Vermeulen's canned music project went into its next phase, which involved investigating the possibilities for producing a "popular" type of electronic music. After his extensive research into stereophony and ambiophony, Vermeulen now returned to mono. Instead of finding a composer or arranger from the professional music entertainment world, he asked Raaijmakers to carry out the experiment. After all, Raaijmakers had trained at the conservatory and gained experience as-

sisting Badings and De Bruyn. The first piece Raaijmakers produced, in just a few days, was originally called “Electronische Rumba,” then “Spoetnik Song,” and finally “Song of the Second Moon.” The electronic music studio was set up again in room 306, where it would remain until November 1960.



Fig. 1.85: Dick Raaijmakers, aka Kid Baltan, during production of “Song of the Second Moon” (October 1957).

The rhythmic basis for “Song of the Second Moon” was made by cutting tape loops that contained various percussive noise sounds. The melodic lines were played on an ondes Martenot or whistled into a microphone with tape echo. In the background, Raaijmakers created a cluster of high-pitched electronic sounds that was almost constantly present. Possibly with the B-side of a 45 rpm phonograph record already in mind, Raaijmakers immediately produced a second piece called “Night Train Blues,” a mournful work for six ondes Martenot parts accompanied by a very simple rhythmic pulse with echo effect.<sup>227</sup>

The two pieces were released under the pseudonym of Kid Baltan<sup>228</sup> for financial reasons. Vermeulen’s view was that the works had been produced under terms of employment, during working hours and as an assignment. After all, he had written in 1945 that for “the ‘canned music’ of the

future, copyright [would] no longer form an insurmountable obstacle.”<sup>229</sup> Nevertheless, he thought it would be nice for Raaijmakers to receive a little extra money.<sup>230</sup>

These pieces got their first public exposure through Philips’ PhiBO, the wired internal radio system that provided music programming to the factory halls at several points during the day. An article in the weekly *Philips Koerier* (Philips courier) stated that the young composer Kid Baltan had created a number of remarkable little pieces. So far, electronic music had only done its sound-broadening work in the classical music arena. But with “Song of the Second Moon” and “Night Train Blues,” it began to widen the domain of popular sound. According to the article, the listeners in the factories were surprised to hear these curious, unfamiliar sounds. Somebody said, “Sputnik,” which was spot on, since that was what had inspired Kid Baltan to compose the rumba-like “Song of the Second Moon.”<sup>231</sup>

In fact, the work’s original title, “Electronische Rumba,” was changed only after others had made the connection with the Russian satellite launched on October 4, 1957. Sputnik transmitted sounds that were picked up by radio amateurs all over the world, and the electronic background sounds in Raaijmakers’ song showed similarities with them, but these were unintentional. This coincidence was probably why “Song of the Second Moon” got so much Dutch press attention. Practically every newspaper took notice of it.



*Fig. 1.86: Room 306 in January 1958, containing electronic drum with additional loudspeaker (1); Philips 9710M loudspeakers (2); Philips 10039 tape recorders (3); Philips EL3509 tape recorder (4); fader box (5); octave filter (6); Philips AC millivolt meters (7); Philips GM2315 sine wave generator (8); Philips GM5655 oscilloscope (9); loudspeaker for the ondes Martenot (10); Philips custom-built tape loop recorder/player (11); Philips EL3516 semiprofessional tape recorder (12); ondioline (13); ondes Martenot (14); and grand piano (15).*

It was not until June 1958 that “Song of the Second Moon” was released on record. “Night Train Blues” had been rejected as a B-side, and Raaijmakers had therefore created another popular work in April. This, however, was not an original composition but an arrangement of Kenneth Alford’s<sup>232</sup> “Colonel Bogey March.” The piece had always been successful but had become immensely popular after appearing in the 1957 film *The Bridge on the River Kwai*. After the release of Kid Baltan’s version, Alford’s widow, who had not been asked for permission beforehand, threatened to sue, and the record was withdrawn from the market. From then on, it was only distributed by Philips as a business gift.<sup>233</sup>

In March 1959, Vermeulen sent two pieces of popular electronic music (presumably both sides of the single) to the composer Vladimir Ussachevsky (1911–1990) at Columbia University. For Vermeulen, the two works had shown “that electronic music need not be subjected to the dogmatics of either ‘Musique Concrète’ or ‘Serial Music.’” He asked Ussachevsky for his opinion, since he himself was “too conservative in [his] music tastes to be able to judge them.” According to Vermeulen, Raaijmakers was “convinced that for his [Raaijmakers’] own devel-



Fig. 1.87 and 1.88: The original 1958 cover for “Song of the Second Moon” and a second version.

opment he should see something of the world outside Holland. He would prefer to go to New York and, if possible, to work with you [Ussachevsky] at Columbia University. [...] Though we will much regret his leaving us, we have to agree that a stay abroad will broaden his general as well as his musical and technical education.”<sup>234</sup> It is unknown whether Ussachevsky ever replied, but Raaijmakers never went to New York.

### Tom Dissevelt’s *Electronic Movements*

On June 5, 1958, Vermeulen had a meeting with Theo van Dongen, the program deputy of the popular music department of Philips’ Phonographic Industries. Given the success of Kid Baltan’s popular electronic music, they were considering using electronic music on a series of phonograph records for children about space travel and other subjects. A meeting with bass player and arranger Tom Dissevelt (1921–1989), who might be willing to produce another popular tune with Raaijmakers, was therefore scheduled.<sup>235</sup>

Dissevelt had studied trombone and clarinet between 1939 and 1943 at the conservatory in The Hague but left before receiving a degree. After that, he took private double bass lessons from Herman Stotijn of the The Hague Philharmonic. The double bass became his main instrument, and he moved into jazz. Shortly after the war, he traveled to the Dutch East Indies (which became the Republic of Indonesia in 1949) to play with Jos Cléber’s orchestra and other bands. In 1947, he went on a long tour with jazz singer Rita Reys (1924–2013), drummer Wessel Ilcken (1923–1957) and the orchestra of saxophonist Piet van Dijk (1916–1978). Around 1955, Bep Rowold (1912–1968), saxophone player and leader of the Dutch dance orchestra the Skymasters, hired Dissevelt as a double bass player and arranger. Dissevelt was known for his progressive arrangements of light music. In 1957, he arranged and conducted one side of the LP *The Cool Voice of Rita Reys No. 2*, released on the Philips





Dissevelt made his first electronic work, "Whirling," in the Philips Research Laboratories studio in October 1958 with Raaijmakers' assistance.<sup>240</sup> Raaijmakers had reservations at first, since he saw the entry of the professional Dissevelt as a disqualification of his own popular works, which had, after all, been well received. But soon the two men were finding great joy in their collaboration. They produced a second piece, "Syncopation," in November of the same year. Van Dongen was pleased with the result and wanted two more pieces that could be released on an EP with the first two.<sup>241</sup> During work on "Syncopation," Dissevelt and Raaijmakers were visited at the Philips studio by a VARA television crew. Raaijmakers explained on camera how to produce various sounds and demonstrated the use of tape loops.<sup>242</sup> A thirty-second excerpt of "Syncopation" was also used as background music for a VARA TV game show when time was running out for contestants to answer a question.

Fig. 1.92: Excerpt from p. 4 of Tom Dissevelt's manuscript for "Vibration," in which a succession of twelve large chords conclude with a cluster of twelve chromatic tones.

Rhythmically, Dissevelt's works benefited greatly from a new tape loop recorder/player designed and built by Philips. Up to four rhythmic loops and repeating bass lines could be played simultaneously while staying in sync, since they were driven from a single capstan motor.

When one compares the four works Dissevelt made at Philips Research Laboratories, the first has a relatively conventional approach, with the majority of the layers in the composition



played on keyboard instruments (besides a grand piano and an ondes Martenot, the studio now also had an ondioline, also manufactured by Maurice Martenot). These parts were often played slowly and in low registers and then transposed up through faster playback on a tape recorder. However, Dissevelt increasingly preferred to create the various voices of a work out of individually produced sounds that were then spliced together, in a process that was much more time-consuming. But this allowed the compositions to make much better use of the new possibilities of the electronic medium. The first page of the manuscript for Dissevelt's fourth piece, "Vibration," therefore contains a table that gives the durations of the notes in centimeters of tape. Harmonically, too, "Vibration" is much more complex than the other works. Although it is not dodecahonic in the strict sense, sketches indicate the use of a row and its inversion as the basis for the melodic material and the chords. "Vibration" ends with a succession of twelve chords, each containing between six and eight different pitches, after which all the chromatic tones are sustained as a cluster. The four works Dissevelt produced in the Philips studio with technical assistance from Raaijmakers were released as the *Electronic Movements* EP on the Philips label (430 736 PE).

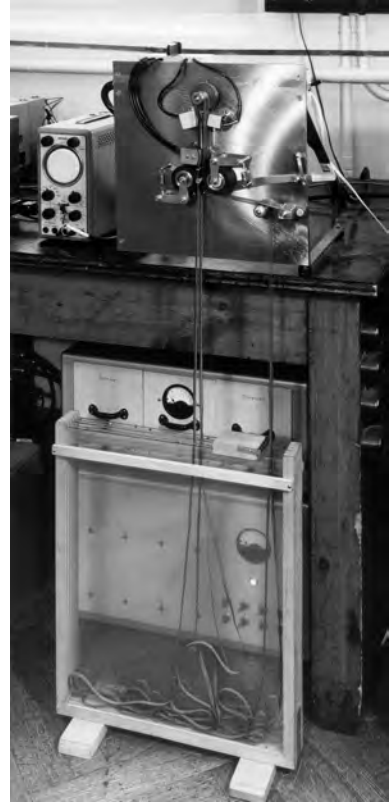

1.90: Custom-built Philips tape loop recorder/player.

## More Electronic Music by Henk Badings

After *Variations électroniques*, Badings composed *Geluid der Werkelijkheid* (Sound of reality, January 1958; radio version, November 1958), which premiered at the opening of the new auditorium at the Rijksakademie voor Beeldende Kunsten (National academy for the fine arts) in Amsterdam. In accompaniment, the robot *CYSP 1*, created by the artist Nicholas Schöffer (1912–1991), moved around on stage (its name was composed of the first two letters of "cybernetics" and "spatiodynamic" respectively).<sup>243</sup> Schöffer had collaborated with Philips on the Spatiodynamic Tower for the 1956 International Building and Public Works Exhibition in Paris. In addition to its extraordinary height, the tower featured a number of metal plates of various colors and angles. Pierre Henry (1927–2017) composed twelve different se-

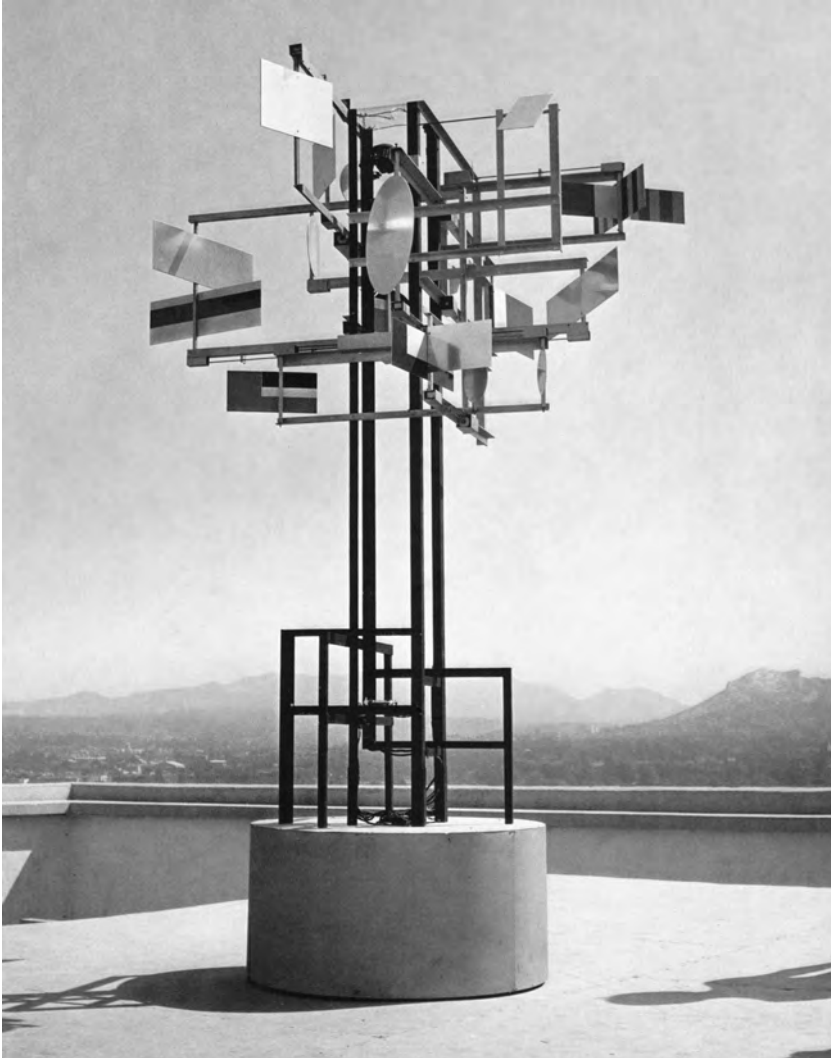

Fig. 1.93: Nicholas Schöffer's "CYSP 1" robot on the roof of Le Corbusier's *Unité d'Habitation* in Marseille.

quences of *musique concrète* for it based on the vibrations of the metal plates. Philips supplied an "electronic brain" that enabled the tower to respond to variations in the sounds, light and temperature around it.<sup>244</sup> The cybernetic sculpture *CYSP 1* had a similar Philips electronic brain. It had complete independence of movement as well as axial and eccentric rotation, which set its sixteen pivoting polychrome plates in motion. *CYSP 1* had made its first appearance in 1956 at the Théâtre Sarah-Bernhardt, as part of a ballet by Maurice Béjart (1927–2007), with *musique concrète* by Henry. A second performance of the ballet had been given on the roof of Le Corbusier's *Unité d'Habitation* building during the Festival de l'Art d'Avant-Garde in Marseille (August 4–14, 1956).<sup>245</sup>



*Fig. 1.94: Nicholas Schöffer's Spatiodynamic Tower in Paris.*

Badings composed the suite *Mens en Machine in Eindhoven* and the ballet music *Evolutions* for the Hannover ballet in the same month as *Geluid der Werkelijkheid*; in fact, all of these works were based on the same musical material. It was the beginning of a very productive period for Badings, who produced no fewer than nine works at the Philips studio between January 1958 and May 1960, with a total duration of more than four hours.

A remarkable composition by Badings is June 1959's *Capriccio* for violin and electronic accompaniment, the first work in the Netherlands to combine the playing of a traditional in-



Fig. 1.95 and 1.96: Joke Vermeulen, Henk Badings and Dick Raaijmakers in Gravesano, August 8, 1959.

strument with electronic parts on tape. The work was written for Roelof Vermeulen's daughter Joke, who performed the violin part at its premiere in Gravesano on August 8, 1959, during the fifth anniversary celebrations of the Centro Sperimentale Electroacustico in Gravesano.<sup>246</sup>

It was exactly five years since Vermeulen had demonstrated his electronic stereo reverberation system and the concept of ambiophony at the 1954 Musik und Elektroakustik conference (see Chapter 2, 53–9). Now he again gave a lecture on ambiophony. While in 1954 the complete reverberation system had been brought to Gravesano for demonstration, this time, a four-channel recording of a minuet by Wolfgang Amadeus Mozart on one-inch tape was played instead. According to Vermeulen, the same effect could be obtained with just four loudspeakers through the application of the principle of stereophony, which made it possible to place a phantom sound source at any point between two speakers.<sup>247</sup> The main music was played from two channels of the tape through two loudspeakers in the front corners of the auditorium, while the two speakers in the rear corners reproduced only the added artificial reverberation as recorded on channels three and four.<sup>248</sup>

Scherchen himself demonstrated his "radiating wall," an arrangement of twenty speakers designed for distortion-free reproduction of the deepest frequencies, and the "active loudspeaker," which was a "pulsating sphere" with 32 small speakers evenly distributed over its surface. According to a report of the event in the *Gravesaner Blätter*,

All participants at the demonstration were deeply impressed. Orchestra, choir and soloists of Bach's *St. Matthew Passion* actually seemed to come into the room when Scherchen's recording of this masterwork was put on the turntable. The spaciousness of the sound was most astonishing and so was the absolute lack of harshness and unnatural coloration inherent in every normal loudspeaker reproduction.<sup>249</sup>

The next series of sound demonstrations that day came from the Siemens laboratory for electronic sounds in Munich. The composer Joseph Anton Riedl (1929–2016) presented recordings made with the so-called punched tape technique, a method developed for “programming” the production of electronic sounds.<sup>250</sup> The last sonic demonstration was of Iannis Xenakis’ (1922–2001) electronic composition *Analogique B*, in which he applied his concept of “screen”: a temporal unit within which the parameters of pitch region, dynamic intensity, and density are specified. An early example of a “granular synthesis” approach, it is now generally considered to be a milestone in the history of electronic music.<sup>251</sup> The piece by Xenakis was followed by Badings’ *Capriccio*. The live sound was reported to have blended remarkably well with the electronically produced material.

The evening’s electroacoustic performances were supposed to take place at Scherchen’s open-air theater but were unfortunately brought to an early end by a thunderstorm.<sup>252</sup> Badings had brought a second piece to Gravesano,<sup>253</sup> but since there are no accounts of the actual performance of *Elektromagnetische Klankfiguren* (July 1959, five minutes, four tracks),<sup>254</sup> it was presumably one of the works on the evening program that had to be canceled.<sup>255</sup>

## **Ton de Leeuw’s *Antiphonie* for Wind Quintet and Electronic Sounds**

In Vermeulen’s meeting with Van Dongen of Philips’ Phonographic Industries on June 5, 1958, they did not just talk about continuing the popular electronic music experiments. They also discussed Peter Schat (1935–2003), Hans Kox (1930–2019) and Jurriaan Andriessen (1925–1996) as possible candidates for producing more electronic classical music in the Philips studio.<sup>256</sup> But it was not until March 1960 that another academically educated composer was invited to produce a work at Philips. That composer was Ton de Leeuw (1926–1996). Like Badings, De Leeuw had composed works at the Dutch national radio studios, and he had won the 1956 Prix Italia for his radiophonic oratorio *Job* for soloists, mixed choir, orchestra and



*Fig. 1.97: The second performance of Ton de Leeuw’s “Antiphonie” with the Danzi Quintet at the Kurhaus in Scheveningen, August 25, 1960. The performers are deliberately spaced apart on stage to avoid the homogeneity of the traditional wind quintet sound. Dick Raaijmakers is on stage behind the tape recorder and mixing desk.*

electronics, two years after Badings won the same prize for *Orestes*. De Leeuw studied composition with Badings from 1947 until 1949 and then moved to Paris for a year to study with Olivier Messiaen (1908–1992) and the Russian composer Thomas de Hartmann (1885–1956). Between 1950 and 1954, he studied non-European music with the ethnomusicologist Jaap Kunst (1891–1960). De Leeuw was the first Dutch composer to apply serial techniques in electronic music (*Elektronische studie*, 1957–1958), and his *String Quartet No.1* (1958) is one of the first Dutch serial compositions for instruments.<sup>257</sup> *Antiphonie*, which De Leeuw produced at Philips in 1960, was written for the Danzi Quintet and four channels of electronic sounds.

Prior to producing *Antiphonie*, De Leeuw had started giving a series of radio lectures about experimental music for the AVRO broadcasting company in the 1957–1958 season.<sup>258</sup> The series focused entirely on the developments in dodecaphonic and electronic music in Germany and France (including that of Varèse). The lectures were also printed in a booklet, which included a discography for suggested listening. Although Badings had been using electronic sounds since 1952, he was not mentioned in the booklet once. By the time De Leeuw began working on *Antiphonie*, his relationship with his former teacher had become difficult, owing to a conflict around the Contactorgaan Elektronische Muziek (Electronic music contact organization) (CEM) (see Part 3). According to Raaijmakers, who assisted De Leeuw during his work at Philips, De Leeuw would only set foot in the studio after being assured he would not run into Badings. De Leeuw, in turn, had made Vermeulen furious by inappropriately applying mathematics in the proposal for the piece he wanted to compose at Philips Research Laboratories. Vermeulen stated that he could not allow someone who had made such mistakes into the studio.<sup>259</sup>

*Antiphonie* premiered in the small hall of the Amsterdam Concertgebouw on June 18, 1960, during the Holland Festival.<sup>260</sup> In the program notes for the premiere, besides explaining the compositionally motivated approach to the spatial arrangement of his sound sources, De Leeuw expressed a critical opinion of the Eindhoven studio's output. He wrote:

The performers are all on stage, but they are widely spaced so as to break with the homogeneity of the traditional wind quintet. An effort is made for a spatial distribution [...] that does not stand on its own but results from a serial way of writing. After all, the aim of serialism is to split up the sound and individualize the musical elements. [...] Nothing is more dangerous than a well-equipped electronic music studio (such as the Philips studio in Eindhoven, in fact). "Anything is possible" quickly leads to sensationalism and an impoverishment of the creative consciousness. In this sonic world, it is more necessary than ever for the composer to restrain himself [...]. In this respect too, the serial composition technique is pre-eminently relevant; it leads to utmost concentration and to the ultimate reduction of starting material.<sup>261</sup>



## The Composer Dick Raaijmakers

Dick Raaijmakers started taking private piano lessons in 1942 and began composing his first pieces soon afterwards, some lasting as long as two hours. His teacher paid no attention to his compositions, and later, when he was a piano student at the conservatories in Tilburg and The Hague, neither did his professors. Raaijmakers had stopped composing by the time he graduated from the conservatory in The Hague in November 1953.<sup>262</sup> Between 1958 and 1960, Badings was regularly invited to stay at the Raaijmakers' and his parents' home in Eindhoven during periods when he was working at the Philips studio (he lived a couple of hours north in Bilthoven). On one of these occasions, Raaijmakers dared to show his manuscripts to Badings, who examined them carefully. According to Badings, Raaijmakers' talent should have been developed at an early age, and he thought it was a shame that no teacher at either conservatory had offered him composition lessons.<sup>263</sup>

Although Raaijmakers says he has never considered Kid Baltan's "Song of the Second Moon" (1957) and "Night Train Blues" (1958) to be compositions (he has expressed embarrassment at being the author of these popular works for many years and even attempted to erase all existing copies of "Night Train Blues"), they were in fact his first creations after he stopped composing for the piano. His interest in the avant-garde was not triggered until after his first collaboration in August 1958 with Dissevelt, who made him aware of works by Stockhausen and others.

In October of that year, Raaijmakers assisted Badings with the performance of Badings' *Dialogues for Man and Machine* and *Genese* during the International Days of Experimental Music at the Brussels World's Fair (October 5–10, 1958). Raaijmakers was deeply impressed by Luciano Berio's electronic composition *Thema (Omaggio a Joyce)*, which was featured in the same series of concerts. Back in the studio Eindhoven, in his innocence, Raaijmakers asked Badings if they could make something similar. Not willing to discuss this, Badings replied, "Yes, we could, but now let's get back to work."<sup>264</sup>

Vermeulen made clear that he had started taking Raaijmakers' talent more seriously when he sent him to the Donaueschinger Musiktage festival on October 18 and 19, 1958, to witness performances of Stockhausen's *Gruppen für drei Orchester* and the premiere of Pierre Boulez's *Poésie pour pouvoir*. On his return, Raaijmakers wrote a report that not only gave a detailed eyewitness account of these historic events but displayed the critical attitude that would underlie many of his works in his future career as a composer:

The ideal that Stockhausen had in mind was to surround the audience with orchestral elements in a dome-shaped hall. But in spite of this, for this particular performance, only one-fifth of the audience found itself between the orchestras, which were positioned at right angles to one another, while the rest of the audience only saw an extremely wide orchestra, without notably new properties.



[...] Apparently, a new organization of listening is addressed here, where “direction” prevails over “timbre.” [...] The second work that received wide attention was *Poésie pour pouvoir* by P. Boulez, for three orchestras and five loudspeaker groups. Here, an acoustical thought was chosen as a starting point: a spiral-shaped movement of sound. An attempt was made to realize this by hanging a loudspeaker column at the top of the hall at an angle of approximately 45 degrees to the floor, which additionally could rotate while maintaining this angle, thereby covering the entire hall. Underneath this, the three orchestras were positioned in the middle of the hall at three different heights. [...] There were four loudspeaker groups on the four walls. Each group consisted of a special low-tone radiator with an outer dimension of 2.5 by 2.5 meters, and ten loudspeaker columns made by Telefunken for the middle and higher frequency ranges. Finally, the audience sat around the members of the orchestra in twelve groups. The electronic sound-part presented was very disappointing and of bad quality; vague, muffled, predominantly low sounds in reverberating shreds did not evoke any sound spiral whatsoever. Similar sounds came from the rotating column, their direction determined by an enormously high level of modulation noise. [...] What remains is to address the discrepancy between effort and result: the orchestra had 110 members with three conductors. Furthermore, there was an enormous sound installation with 45 loudspeakers, of which four were special low-frequency reproducers, and the rotating column, an eight-track tape recorder with complete service installation, five technicians, and, finally, four months of preparations in the electronic studio of Südwestfunk in Baden-Baden, which also handled the reproduction in the hall. The work itself lasted only eight minutes.<sup>265</sup>

In November 1959, Raaijmakers composed his first “serious” electronic piece for concert performance, *Tweeklank* (Diad), for which he received the 1959 incentive prize for young artists from the city of Eindhoven. Vermeulen was on the jury and had encouraged Raaijmakers to create a piece especially for the competition. Raaijmakers was allowed to use the Philips Research Laboratories studio during working hours for this purpose. The jury stated that he had demonstrated his ability to put his thoughts into musical form, showing evidence of personal vision and musical creativity. Additionally, he had proven his complete control of the still-unusual media used to create electronic music and had used them in the service of a musical intention that betrayed familiarity with classical forms as well as the free processing of experimental sounds.<sup>266</sup> *Tweeklank* has a simple A-B-A form, with the first part written in a rather conventional style. This part is dominated by a two-voiced canonic toccata. The second part consists of nine elementary noise forms that blend with each other in increasing complexity. The third movement is the shortest and recalls the first part.<sup>267</sup>

To increase the depth of the stereophonic panorama, Raaijmakers explored the contrast of in-phase and out-of-phase sounds in the second part. *Tweeklank* was renamed *Contrasts* for release on phonograph record (as well as Badings' *Evolutionen*, *Capriccio* and *Genese*).<sup>268</sup> To increase the depth of the stereophonic panorama, Raaijmakers explored the contrast of in-phase and out-of-phase sounds in the second part. When the stereo record was played back in mono (as most people would have done in those days), the out-of-phase sounds were canceled out completely. The record was also released in the United States, where in spite of the out-of-phase sounds, it was pressed in mono as well as stereo.<sup>269</sup>

In October 1963, Raaijmakers received a letter from the conductor Victor Di Bello (1933–1997), music coordinator of the Stratford Shakespearean Festival in Ontario, Canada, written on behalf of the festival's music director, Glenn Gould (1932–1982). Gould wanted tapes of electronic works by Raaijmakers other than *Contrasts*, with which he was already familiar. Gould and Grant Strate (1927–2015) of the National Ballet of Canada wanted to stage a performance combining ballet and electronic music at the Stratford festival in summer 1964.<sup>270</sup> In a second letter, Di Bello emphasized that their intention was to have Raaijmakers' music danced to, not used as an entr'acte. The choreography was to be handled by Strate.<sup>271</sup> Raaijmakers sent Di Bello tapes of his own *Pianoforte* (1960) and *Vijf plastieken* (Five sculptures) (1961), of Jan Boerman's (\*1923) *Alchemie 1961*, and Bruynèl's *Resonance I* (1962).<sup>272</sup> Raaijmakers never heard from Di Bello or Gould after sending the tapes to Canada. Gould withdrew from giving public performances in 1964 (he gave his last concert on April 10, 1964) but remained one of the Stratford festival's music directors that year.<sup>273</sup> But Gould returned to Raaijmakers' music in a CBC Radio broadcast of January 10, 1965, entitled *Dialogues on the Prospects of Recording*. Gould said that in electronic music,

the composer in a sense is the performer as well, although it sometimes is necessary for him to seek assistance from technicians who may specialize in some aspects of electronic control. Such a specialist is Dick Raaijmakers, who is both a composer himself and a technical assistant to other composers, notably Henk Badings. [Gould continues talking as an excerpt of *Contrasts* plays in the background.] Raaijmakers' own compositions are relatively uninteresting as music but absolutely fascinating as controlled sound. They are produced with an incredibly precise sonic definition, a sharp focus about line not always realized in electronic music, and the clarity of the sound, operating at sharply etched dynamic levels, very clearly suggests spatial distances. This sort of music, drafted by a man who is primarily an engineer and only secondarily a composer, is concerned with aural effects in much the same way that the current enthusiasm for painting which cultivates purely optical illusion is in many cases contrived by designers who are more concerned with proving a principle of optical control than with creating a work of art as such.<sup>274</sup>

While working as a technical assistant at the Philips studio on the production of De Leeuw's *Antiphonie* in March 1960, Raaijmakers took the opportunity to become more informed about new trends in musical composition. During a walk through the farmland then surrounding Philips Research Laboratories, he asked De Leeuw what serial music was all about. De Leeuw, an expert in the field, took the time to explain thoroughly, and Raaijmakers recalled that he "soaked up the information like a sponge."<sup>275</sup> Later compositions such as *Vijf plastieken* and the first of the series of *Vijf canons* (Five canons) (1964–1967) were strongly influenced by serial composition techniques.

The second and last electronic piece for concert performance Raaijmakers produced at the Philips Research Laboratories studio was *Pianoforte* in May 1960. At that time, the acoustics department had a Neumann KM54 cardioid<sup>276</sup> condenser microphone, used for testing purposes. Raaijmakers tried it out and was astonished by the sound quality, which he found far superior to that which any of Philips' microphones could have delivered. *Pianoforte* was not only the last autonomous composition Raaijmakers produced in Philips' Eindhoven studio, it was also, in retrospect, an aggressive symbol of the end of his work as Badings' assistant.<sup>277</sup> Raaijmakers secretly entered the studio on a Saturday, when no one else was in the acoustics



department. He literally attacked the grand piano's interior parts with all manner of objects, recording the sounds produced with the Neumann microphone. Splicing them together into a five-part structure only took a few more days, and he deliberately did it without any score planned beforehand, in contrast to the assembly-line work he had been doing for Badings for the past three years.<sup>278</sup>

Raaijmakers now also became active as a composer of film music. The partly animated educational film *Achter de schermen*<sup>279</sup> (March 1960), made at the initiative of Philips' electronic market development department, shows the production process for Philips television screens. It was written and directed by Jan Moonen (1925–1999) and produced by the Polygoon Profilti company. At Raaijmakers' specific request, the usual order of production – making the music first and then editing the film according to the structure of the music – was reversed. The film was finished first, and Raaijmakers analyzed it, shot by shot. He then created individual sounds illustrating all the different visual elements in the scenes and spliced them together, to an accuracy of a single frame's duration.



Fig. 1.98 and 1.99: Cover of the Philips LP (opposite page) and the US version on EPIC, containing Dick Raaijmakers' "Tweeklank," by then renamed "Contrasts."

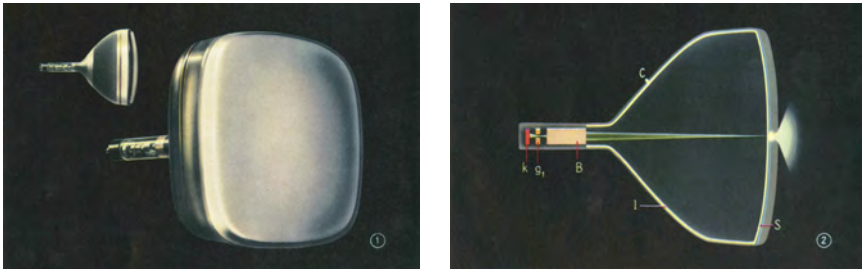

Fig. 1.100 and 1.101: Two images of television screens made for an educational publication of the Philips electronic market development department.

*Achter de Schermen* was soon followed by a second educational film, *Fuel for the Future* (August 1960), on nuclear fusion. It was produced by Hindle Edgar (1905–1984) of World Wide Pictures in London under the direction of Ric Wylam (1919–1997) and made up entirely of animations by Dick Horne<sup>280</sup> and Bob Lumley. Raaijmakers greatly enjoyed making these soundtracks, and the filmmakers were impressed with the results. But much to Raaijmakers' regret, during the last stages of production, a third element was added to each film: a voice-over. To maintain its clarity, the music was placed in the background. Out of frustration, Raaijmakers later combined his favorite parts of the film scores into an autonomous piece, *Mechanical Motions*. It was released in 1961 as the B-side of Tom Dissevelt's *Intersection*. *Mechanical Motions* was the last work Raaijmakers composed under his pseudonym, Kid Baltan.



Fig. 1.102 to 1.107: Six screenshots from the educational film "Fuel for the Future."





sible.”<sup>282</sup> Teer believed the opposite. To him, the fact that you made sound carriers did not imply that you should hire composers. You were not going to produce television programs just because you were selling TV sets – Philips had never considered making creative new TV content, had it?<sup>283</sup> In fact, the company had done just that between 1948 and 1951 (see Chapter 3, 72–7).

At the time when Teer was taking over Vermeulen’s position, the acoustics department had around five scientists, around ten assistants and a few craftsmen in the workshop. Like Teer, most members of the department weren’t enamored of the electronic music activities, and Teer soon decided they should stop. He and the others were convinced that the technology for sound recording and reproduction were still far from perfect and needed further development. There had always been more ideas for new research in the department than practical possibilities, and therefore there was always a list of priorities. According to Teer, if you had to choose whether to invest in electronic music or develop the compact cassette, you should choose the latter. His decision was supported by both the employees of the acoustics department and the directors of Philips Research Laboratories. There was never any conflict – it all happened with a smile. But although electronic music might have been a strange activity for a research laboratory, it, too, had been tolerated with a smile. According to Teer, Hendrik Casimir, the head of physics research, was a great scientist with a broad orientation; for him, things needed to be either important or interesting, and he found electronic music “rather interesting.” Vermeulen had been there so long and achieved so much that it was interesting enough to let him do his experiments for another few years. Vermeulen had a vast network of acquaintances in the cultural/technical world, and the fact that a home was found for electronic music, ensuring it would not disappear into oblivion, was partly his doing. Teer, however, believed that in retrospect, it was better to ask why electronic music had been an activity at Philips Research Laboratories at all than to ask why it had ended.<sup>284</sup>

When Vermeulen gave his lecture in Gravesano at the fifth anniversary celebration for Scherchen’s *Elektroakustisches Experimentalstudio* on August 8, 1959, his retirement was less than two months away. He took the opportunity to look back on his career:

When, 35 years ago, I built my first loudspeakers, I quite naturally supposed that I could best check my results by asking the opinion of professional musicians. It was a great disappointment to say the least, and still worse, that their opinion was more influenced by the quality of the musicians, both composer and interpreter, than by the defects of my loudspeaker. They would prefer the reproduction of good music by a bad loudspeaker to that of bad music by a good loudspeaker. [...] So I came to the conclusion that the reproduction of music was not a musical but a technical problem and that we should not draw musicians into it.<sup>285</sup>



Even in the development of ambiophony and electronic reverberation systems, there had been little or no collaboration with musicians. "Music was still considered as a given object, to be studied as such by scientists, to be handled by the technician according to objective standards. Their subjective taste or musical preferences should not be allowed to enter into their work."<sup>286</sup> At the 1954 Musik und Elektroakustik conference, Vermeulen had been confronted with the pioneering work of Pierre Schaeffer and been "rather surprised that it should be taken seriously by the musicians."<sup>287</sup> And while he had remained skeptical about the use of electronic means in the production of music, as opposed to its reproduction, he "only became convinced by the compositions of Webern and Varèse. If these were indeed the sounds modern composers wanted and tried to produce by traditional instruments, than the electro-acoustician was certainly obliged to offer them the assistance they seemed to need. [...] It was an opportunity to bridge the schism that has grown between art and technology."<sup>288</sup> But at the same time, Vermeulen had learned that a difference in mentality between artists and engineers hindered mutual understanding. When trying to read papers on modern music, he often failed even to understand the meaning of the words. In a letter to the composer Rudolf Escher (1912–1980), Vermeulen wrote that he believed that the avant-garde movement was "based on unhealthy grounds." He agreed with Escher that its arguments were "more pseudo-scientific than truly scientific."<sup>289</sup> According to Vermeulen, verbal communication between artists and scientists was susceptible to misunderstanding, especially when artists borrowed metaphors from scientific language and applied them in a much more general way than scientists' strict habits permitted. But although it was difficult for artists and electro-acousticians to truly understand each other's worlds, the new developments in music forced them to cooperate. It was perhaps better for scientists and engineers to go their own way and not worry too much about artists' theories and dogmas.

The scientist may search for the physical, the physiological and the psychological laws of acoustics and even of music; the engineer may develop and improve procedures and instruments as the spirit moves him. He will place the results of his work at the disposal of the composer and keep his mind open to the stimuli resulting from their use, or even misuse. Then perhaps, someday some composer or musician will use them in an unexpected way, be it a genius to express the deepest sense of our community, be it an artisan to amuse people and make money.<sup>290</sup>

At an assembly of the Contactorgaan Elektronische Muziek (CEM) on March 16, 1959, Vermeulen announced he wanted to remove the electronic music studio at Philips Research Laboratories, since it had become a company in its own right with no reason to exist at a research laboratory. He wanted a university to take over the studio.<sup>291</sup> At another CEM assembly on September 30, 1959, Vermeulen was asked to elaborate on the future studio in Utrecht; in

the meantime, J. H. des Tombe, secretary of the Utrecht University's board of curators, had invited Vermeulen to come and discuss things. Vermeulen had made several proposals to Des Tombe but unfortunately had not yet received an answer at the time of the assembly, and he was due to retire the next day. A CEM representative asked whether Philips would continue to be represented at CEM assemblies, but Vermeulen explained that his successor Teer "didn't like the idea."<sup>292</sup>



Fig. 1.110: Roelof Vermeulen near the time of his retirement on October 1, 1959.

At Vermeulen's retirement festivities on October 10, 1959, a string trio written by Rudolf Escher especially for the occasion was performed. The members of the acoustics department had built a working miniature version of the reverberation wheel as a farewell present. The last official portrait of Vermeulen at Philips was taken while he was sitting at his desk at the Research Laboratories, with the loudspeaker that symbolized the beginning of his career next to him.

Although the decision to close the studio had been made, it took another year before it was carried out. On March 17, 1960, Casimir, Des

Tombe and Vermeulen attended a meeting at the Netherlands Ministry of Education, Arts and Sciences to discuss the new contract to be signed by the university's board of governors, authorized by the Ministry, and by Philips. The contract also stipulated that Raaijmakers would be given the position of scientific member of staff, in a considerable promotion. However, Raaijmakers was still due to attend a meeting in Utrecht, and it was not certain whether his conditions would be accepted.<sup>293</sup>

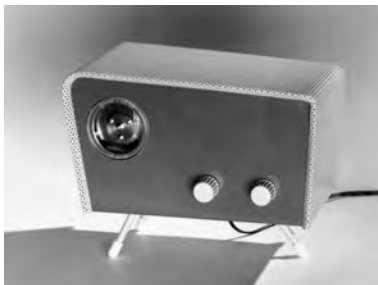

Fig. 1.111 and 1.112: The miniature version of the electronic reverberation system with two playback heads, built as a retirement gift for Vermeulen. The rotating wheel is visible behind the display window on the front panel. An inscription around the display window says "akoestiek - nat.lab 10-10-59."

At the end of October 1960, the Philips studio was relocated to a 1921-built former office building in Utrecht and renamed STEM (STudio voor Elektronische Muziek, the Dutch word *stem* means “voice”). Raaijmakers came to Utrecht with Vermeulen, but their collaboration came to an end in October 1961. Vermeulen resigned as director of STEM on October 22, 1962, and Badings was installed as his successor (see Chapter 10).

## ever since the twenties

an immense variety of Philips electro-acoustical equipment has reached its destination. Philips microphones, amplifiers, loudspeakers and sound recorders were the faithful technical witnesses of more than three decades of evolution in sound registration and reproduction.

In the designing of quality products **research** comes first, and where evolution becomes revolution - and technical instruments play an evermore important part in the musical creation itself - Philips will continue to further the progress of

**EVERY NEW DEVELOPMENT IN SOUND**



**ELECTRO-ACOUSTICAL & SOUND RECORDING EQUIPMENT**



*Edgar Varèse*



*Henk Badings*



*Kud Baltan (l.),  
Tom Dissevelt (r.)*

**ELECTRONIC MUSIC RECORDED IN PHILIPS' PHYSICAL LABORATORIES**

YEAR	COMPOSER	TITLE	TIME IN MIN.	ART	ELECTRO-ACOUSTICIAN	PREMIERE
1956	Henk Badings	Kain & Abel	17½	Ballet-music	J. W. de Bruyn	Holland Festival '56
1957	Henk Badings	Variations	10	Film-music	J. W. de Bruyn	
	Kud Baltan	Electroniques	3	Popular music	B. F. Raaijmakers	
		Song of the Second Moon			Kud Baltan	(gramophone record)
1958	Henk Badings	Sounds of Reality	40	Radio-music	B. F. Raaijmakers	Academy of Monumental Arts, Amsterdam '58
1958	Henk Badings	Man & Machine at Eindhoven	14	Suite	B. F. Raaijmakers	Ballet Hannover '58
1958	Henk Badings	Evolutions	14	Ballet-music	B. F. Raaijmakers	Ballet Hannover '58
1958	Edgar Varèse	Poème Electronique	8	Organized Sound with Images by Le Corbusier	W. Tuk J. W. de Bruyn	Philips Pavilion, Expo, Brussels '58
1958	Henk Badings	Dialogues for Man & Machine	20	Concert-music	B. F. Raaijmakers	1st Days for Experimental Music, Expo, Brussels
1958	Tom Dissevelt	I	3	Popular music	B. F. Raaijmakers	
1958	Henk Badings	Genese	15	Concert music	B. F. Raaijmakers	I.D.F.E.M., Expo
1958	Tom Dissevelt	II	3	Popular music	B. F. Raaijmakers	
1959	Henk Badings	Andros	21	Ballet-music	B. F. Raaijmakers	(at the request of the Netherlands Government)
1959	Henk Badings	Suita Mariale	—	Television-opera	B. F. Raaijmakers	Bessem, Salzburg '59
1959	Henk Badings	The Barrier	—	Opera scene	—	(Neth. Government)
1959	Tom Dissevelt	III	3	Popular music	B. F. Raaijmakers	
1959	Henk Badings	Capriccio	8	Violin solo & al. accompaniment	B. F. Raaijmakers	Gravesano '59
1959	Henk Badings	Electronic Manifestation of Sound	4½	Ballet music	B. F. Raaijmakers	Gravesano '59

Fig. 1.113: Philips advertisement in “Gravesaner Blätter” XV/XVI (1960) erroneously listing Varèse’s “Le poème électronique” as a work produced at Philips Research Laboratories.

**Part II**

**Electronic**

**Music**

**for**

**the**

**Philips**

**Pavilion**

## Chapter 4

# Preliminary Technical and Artistic Outline

### Initial Concept

Ever since the twenties, an immense variety of Philips electro-acoustical equipment has reached its destination. Philips microphones, amplifiers, loudspeakers and sound recorders were the faithful technical witnesses of more than three decades of evolution in sound registration and reproduction. In the designing of quality products *research* comes first, and where evolution becomes revolution – and technical instruments play an evermore important part in the musical creation itself – Philips will continue to further the progress of EVERY NEW DEVELOPMENT IN SOUND.<sup>1</sup>

This Philips advertisement was printed in 1960 in Hermann Scherchen's *Gravesaner Blätter*. The same edition contained "Technical Aspects at the Fifth Anniversary of Gravesano," a report on the event where Vermeulen had given his lecture/demonstration on ambiophony (see Chapter 2, 59–61).<sup>2</sup> The ad featured photos of Varèse, Badings, Baltan and Dissevelt and a list of the works produced so far in Philips Research Laboratories' electronic music studio. The list erroneously contained Varèse's *Le poème électronique*.<sup>3</sup> It is not difficult to detect the spirit of Vermeulen in the advertisement's text; in his Gravesano lecture on August 8, he had mentioned he had become convinced of the quality of Varèse's music. Scherchen's connection with Varèse could have been another reason for Vermeulen to slightly alter historical facts for this particular publication.

Philips has, of course, been named in connection with electronic music mainly because of its ambitious pavilion for the 1958 Brussels World's Fair, for which Varèse wrote *Le poème électronique*. It is indeed hard to overlook a project on which great twentieth-century artists such as Varèse, Xenakis and Le Corbusier collaborated. Ever since the fair, *Le poème électronique* and the advanced system built for its spatial reproduction have generally been considered milestones in the history of electronic music, and the multimedia aspect of the project as a whole has drawn much attention as well. But although in retrospect the production of *Le poème électronique* is widely seen as a part of Philips Research Laboratories' electronic music activities,<sup>4</sup> in fact the two had little to do with each other.

Philips made its decision to present itself at the 1958 Brussels World's Fair around the time of the installation of the studio at Philips Research Laboratories. While the electronic music activities in Room 306 were part of Vermeulen's research program at the labs, the pavilion project was a separate commercial activity that was part of the company's international

marketing, and Varèse became a participant more or less by accident. Initially, the music for the Philips Pavilion was not intended to be avant-garde at all. Varèse stayed in Eindhoven from September 2, 1957, until April 8, 1958; he did not work in Room 306 or any part of the Research Laboratories but in a Philips garage in the Strijp III complex that housed most of the activities for the World's Fair project. That project was facilitated by Philips' commercial ELA division. Paradoxically, during production of *Le poème électronique*, Kid Baltan was working on his electronic dance tune "Song of the Second Moon," the mournful "Night Train Blues" and an electronic arrangement of Alford's "Colonel Bogey March" as part of a research project; all these sounded much more like music created for marketing purposes than Varèse's music.



Fig. 2.1 and 2.2: Philips advertising posters from 1925 (top) and 1929, designed by Louis Kalff.

In September 1954, the government of Belgium officially invited the Netherlands to participate in the 1958 World's Fair. As a result, a special foundation was established in August 1955. Its board invited Dutch companies to build their own pavilions and exhibit their work in the Dutch section of the fair. Only Philips accepted.<sup>5</sup> Louis Kalff (1897–1976), Philips' general art director at the time, was commissioned to outline a plan for the Brussels 1958 Philips Pavilion. Kalff had been appointed as head of Philips' advertising department in January 1925, unusually, since he had trained as an architect.<sup>6</sup> During his first years at Philips, Kalff was concerned mainly with the graphic design of posters and packaging. He and Vermeulen started at Philips almost simultaneously (Vermeulen had arrived in March 1924) and immediately worked together on the development of a loudspeaker; Kalff designed the exterior and Vermeulen the electronics (see Chapter 1, 18–22).

Kalff designed lighting architecture for world's fairs in Barcelona (1929), Antwerp (1930), Brussels (1935) and Paris (1937) on behalf of Philips' Lichtadvies Bureau (office of lighting advice) (LiBu). And with the architect Henri Eduard van den Pauwert (1895–1981), he designed the Philips Pavilions for the 1935 Brussels World's Fair.<sup>7</sup> They had glass display cases containing a selection of new Philips products and scale models of Philips factories around the world,<sup>8</sup> and an installation that broadcast music throughout the fair. Kalff's work was highly valued, and he received the Order of Leopold II for his work in



Antwerp and an honorary medal from the Société Nationale des Architectes Français (National society of French architects) for Philips' contribution to the Brussels fair. He was appointed Philips' general art director in 1947, a year after Vermeulen became head of the Philips Research acoustics department.

By the time Kalff was asked to take charge of Philips' contribution to the 1958 Brussels World's Fair, he had seen photos of Le Corbusier's Notre Dame du Haut chapel in Ronchamp, France, completed in 1955. He was impressed and decided to commission Le Corbusier for the new Philips Pavilion. It was presumably the effect of the colored windows on the interior that had caught Kalff's eye; indeed, he initially asked Le Corbusier to design only the interior of the pavilion.

On January 9, 1956, Kalff therefore wrote a letter to Mr. R. d'Aboville of Philips France in Paris, asking him to contact Le Corbusier. In it, he described the character of the pavilion Philips had in mind. Inside, the company wanted to present a "synthesis of light and sound" in a completely new, modern form. It envisaged a large dome with walls bathed in light and color continuously changing to the rhythm of modern stereo music; at the end of the show, a more or less abstract monument would become visible at the center or rear of the dome. This monument would symbolize Philips' "family tree" of products. When the audience left the space, they would walk down a corridor, where they would see the electronic devices that automatically ran the exhibition. According to Kalff, the show's success would depend entirely on presentation, and for this reason Philips wanted to commission famous artists: it wanted Le Corbusier to design the pavilion, Osip Zadkine (1890–1967) to create the monument and Benjamin Britten (1913–1976) to write the music. In the same letter, Kalff suggested that the interior of Le Corbusier's chapel at Ronchamp contained elements that might be used in the Philips Pavilion.<sup>9</sup>

The large dome Philips imagined was presumably inspired by a building called the Dome of Discovery, by the architect Ralph Tubbs (1912–1996); it had been part of the Festival of Britain in 1951.<sup>10</sup> The British government had planned a series of exhibitions on the arts, architecture, science, technology



Fig. 2.3: Postcard of the Philips Pavilions at the 1935 Brussels World's Fair.

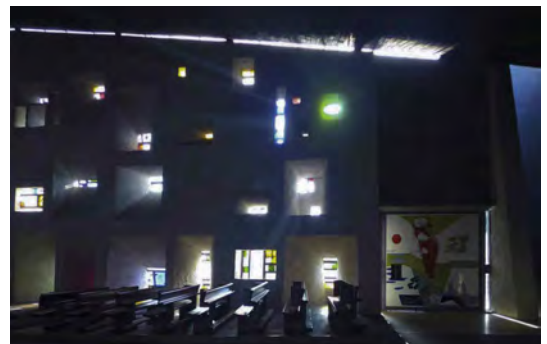

Fig. 2.4: Interior of Le Corbusier's chapel in Ronchamp.



an audience for the first time in 1953, this system had only been permanently installed in concert halls since 1954. As mentioned earlier, Philips' ELA division sold one such system to the Teatro alla Scala in Milan; it was inaugurated by Herbert von Karajan on December 7, 1955 (see Chapter 2, 53–9), about a month before Kalff wrote his letter to d'Aboville. So when he wrote "modern stereo music," he was presumably referring not only to the novelty of stereophonic recording and reproduction techniques in general but also specifically to Vermeulen's electronic stereo reverberation system.

The Philips product family tree Kalff described was not a new idea. A similar model for visualizing the history of the Philips product line had been printed in Karel Sartory's book *Im Dienste des Elektrons*, written in 1941 to commemorate the company's fiftieth anniversary.

The question of why Kalff picked Zadkine to create the "abstract monument" for the pavilion cannot be answered with certainty. However, the artist had been known in the Netherlands at least since 1925 through his friendship with the painter Hendrik Wiegiersma (1891–1969),<sup>13</sup> who lived in Deurne, less than 24 kilometers from Eindhoven. Zadkine had created a sculpture that had attracted a lot of attention in the Netherlands in the years after the Second World War. He had seen the impact of the 1940 German bombing of Rotterdam during a visit to the Netherlands in 1947, and it had left a deep impression on him. He displayed his design for a monument to the destroyed city in an exhibition at the Stedelijk Museum in Amsterdam in 1948. The directors of the department store De Bijenkorf considered it suitable for a monument they wanted to build in Rotterdam in memory of Jewish employees who had not survived the war. The piece was cast in bronze and exhibited at the Museum Boijmans<sup>14</sup> in Rotterdam six months later. In 1951, the city council accepted the sculpture, and Zadkine was commissioned to enlarge it to a height of six meters. It was finally installed in 1953. The sculpture gave visual form to the desperation caused in the people of Rotterdam by the violence of war, and they identified with it. It soon became a symbol of the Netherlands' rebirth after the war.

We cannot know for certain why Kalff wanted Benjamin Britten to write the music for the pavilion either. Britten had, however, achieved international fame after his opera *Peter Grimes* premiered in June 1945. His importance in Britain's postwar cultural life was enhanced by his founding of the English Opera Group in 1946 and the Aldeburgh Festival in 1948. Of particular interest in relation to the Philips Pavilion is his composition *The Young Person's Guide to the Orchestra* (op. 34), which was commissioned for the film *Instruments of the Orchestra*,



Fig. 2.6: Osip Zadkine's sculpture "La ville détruite" (Destroyed city) in Rotterdam. Photo by Marinus Dekker.

produced by the Crown Film Unit in 1946. In the film, the music, also known as *Variations and Fugue on a Theme of Purcell*, was conducted by Malcolm Sargent (1895–1967) and performed by the London Symphony Orchestra. The work's demonstrative character is enhanced by the use of a voiceover explaining the sounds of the instruments and their functions in the orchestra. It begins with the full orchestra playing the main theme from Henry Purcell's *Abdelazar*, after which variations are presented separately by the woodwinds, brass, strings and percussion instruments. More variations are subsequently played by the individual instruments that make up these groups. Then comes the fugue, in which all the instruments combine in a polyphonic structure. At the end, the original theme appears once more.<sup>15</sup> In the pavilion, Philips planned to use artificial reverberation and stereophony to create an illusion in the members of the audience that sound sources were moving around them and to turn a dry, narrow acoustic space into something that sounded more like a cathedral.<sup>16</sup> It is easy to imagine how well a recording of a piece by Britten similar to *The Young Person's Guide* would have suited the purpose of a demonstration of this technology.

According to Kalff, on top of all this, the pavilion's walls would be bathed in light and color that would continuously change in time with the music. His idea shows striking similarities with elements of Walt Disney's *Fantasia*. When Vermeulen had visited Stokowski in New York in 1948, they had discussed the difficulty of creating imagery to accompany a musical reproduction without an orchestra. Stokowski believed colors without clear shapes, as seen in certain parts of *Fantasia*, were best suited for grounding the eye (see Chapter 2, 40–4).

Hence, the initial concept for the Philips Pavilion can be summarized as follows: a building like the Dome of Discovery, containing a piece of demonstration music like Britten's *The Young Person's Guide to the Orchestra*, played on a system that allowed the sound to move through the hall and the acoustics to be changed by means of electronics. A sculpture symbolizing the evolution of the company and its products would be created by Zadkine, whose work was associated with the Netherlands' resurrection after World War II. The interior of the pavilion would resemble that of Le Corbusier's chapel at Ronchamp, with colored light projected on the walls and changing to the rhythm of the music, similar to the moving colors seen in the more abstract parts of Walt Disney's *Fantasia*.

## The Electroacoustics Division (ELA) and Its Studio

In the technical part of his plan for the Philips Pavilion, Kalff focused much more on the commercial activities of the electroacoustics division (ELA) than the scientific activities of Philips Research Laboratories. The division was renamed and expanded in a reorganization at Philips in 1946 that established the Hoofd Industrie Groepen (HIGs), or main product divisions. All activities involving the selling and manufacturing of professional recording and projection equipment, microphones, amplifiers and loudspeakers were joined within ELA. It consisted of a commercial organization and a factory.



Philips had had an audio demonstration studio before the Second World War, but it was lost in the British bombing of the company's Eindhoven factories on December 6, 1942. Shortly thereafter, a plan was made to build a new, improved demonstration studio as soon as circumstances allowed it. The new studio would also have facilities for film projection, sound recording, film sound dubbing, and radio broadcasting. The ELA studio was completed in early 1948, with an interior designed by Kalff. It was located in the "Veemgebouw" (A Philips warehouse building completed in 1942) and had a microphone room, a film projection room, a control room and a recording room. Sound sources such as microphones, magnetic tape recorders, a Philips-Miller recording system, phonographs and radio receivers could be connected to any amplifier and reproduced through any speaker through the use of an automatic switching system with relays. The demonstration hall's central element was a sound wall that could contain up to twelve speaker systems. Opening the middle section of the sound wall revealed the projection screen.<sup>17</sup> After Philips Research Laboratories finished developing its electronic stereo reverberation system, ELA handled promotion and selling of the system and installed one in its studio for demonstration purposes.

Kalff's interior design for the studio was not his only connection with ELA. He supervised the industrial design of many products sold by the division, and he also collaborated with Willem Tak (1908-1985). Tak had started at Philips in 1943, working as an acoustics advisor for Kalff's lighting advice office before moving to Vermeulen's acoustics department at Philips Research Laboratories. Tak then transferred to the department that became ELA after the war.<sup>18</sup> There, he played an important role in the selling of electronic systems, including the reverberation installation. In 1954, Kalff and Tak together published an article about ceilings that distributed light and sound in the *International Lighting Review*, a magazine with close links to Philips. This type of ceiling had been used successfully in factory halls, offices, department stores and public spaces, such as Brussels' central railway station.<sup>19</sup>

Tak would later write a test scenario for the presentation in the Philips Pavilion, which would include music, sonic effects



Fig. 2.7: Ceiling with combined distribution of light and sound by Kalff and Tak, installed at the Bank für Gemeinewirtschaft in Cologne, Germany.



Fig. 2.8 and 2.9: The Veemgebouw building in 1951, with its experimental TV transmission tower (top), and ELA's demonstration studio with the projection screen visible.



Fig. 2.10 and 2.11: Philips-Miller playback device and phonographs (left) and a Philips-Miller recording system at the ELA studio in 1948.

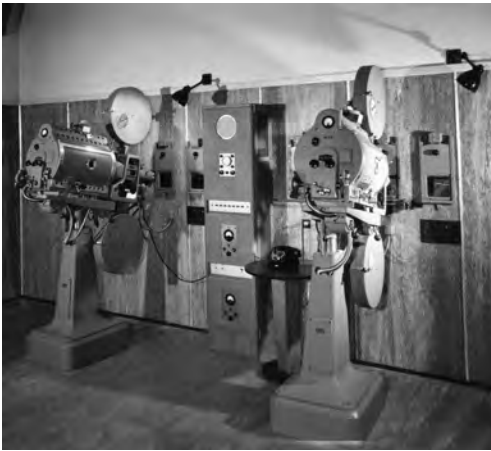

Fig. 2.12 and 2.13: Film projectors (left) and the closed sound wall of the ELA studio in 1948.



Fig. 2.14 and 2.15: Microphone room (left) and control room at the ELA studio in 1948.



and visual elements. He would work as one of Varèse's assistants and take responsibility for the acoustics and electroacoustics of the pavilion. Through the project, he would also be hired to give acoustic advice for other projects by Le Corbusier.

## **ELA at the 1958 World's Fair**

The Philips Pavilion was only one of many pavilions at the World's Fair for which ELA supplied the sound and projection equipment. On the cover of the May 1958 edition of *The ELAgraph*, a magazine in which the division reported on its activities, the main headline was "Electro-Acoustics in Brussels: The Voice of Philips Is Heard Everywhere at the Universal Exhibition 1958."<sup>20</sup> Further emphasizing the scale of Philips' presence, the introduction to the article stated:

Philips lamps flood the exhibition grounds. Towards nightfall unheard-of amounts of kilowatts are converted into floodlighting, festive lighting and normal illumination. But all through the day the widest variety of Philips electro-acoustic equipment ever supplied for one specific occasion performs its less obtrusive, but clearly audible task.<sup>21</sup>

The article went on to list the main pieces of equipment supplied by ELA. In addition to the installation for the Philips Pavilion (to be described later), there was a large Philips sound installation in the Grand Auditorium that included an artificial reverberation system, mixing and control desks, stereophonic tape recorders and a six-channel HF wireless simultaneous-interpretation system operating thousand lightweight receivers. A similar wireless system with 350 receivers was installed in the small auditorium.

On May 1, 1958, the USA pavilion held the continental European premiere of *South Pacific*, a Rodgers and Hammerstein musical filmed in Todd-AO, a high-resolution widescreen film format developed in the mid-1950s that included a curved screen and multichannel sound. The film ran for four weeks on Philips DP70 multi-purpose film projectors installed specially for the occasion.

Other ELA equipment in use at the fair included public address systems and two five-channel recorders for providing automated commentary on exhibits. Other pavilions supplied with film projectors, PA systems, five-channel recording equipment and simultaneous-interpretation systems were



*Fig. 2.16: Philips PA loudspeaker at the exhibition grounds.*

Canada's, Austria's, Argentina's, Yugoslavia's, Turkey's, Spain's, Portugal's and Switzerland's, as well as the pavilions for industrial enterprises, town planning and road construction, savings banks, energy, the Belgian colonial information center Inforcongo, IBM, the Université libre de Bruxelles, the Chamber of Commerce, the government of Brabant, and Swiss watchmakers, and the Hall of Elegance.<sup>22</sup> Philips set up a special press center in the main Philips Belgium building on Rue d'Anderlecht to inform journalists about its presence at Expo 58.



Fig. 2.17 and 2.18: The Grand Auditorium (left) and its control room, with an audio control desk in the foreground, a control desk for incoming radio and television signals, and, at the rear, the artificial reverberation system.



Fig. 2.19 and 2.20: Philips 70 mm widescreen film projectors in the USA pavilion (left) and the Philips press center on Rue d'Anderlecht.

## Sound and Light Spectacles

It has been suggested that ELA became involved in *son et lumière* projects as a consequence of the technologies developed for the Philips Pavilion. But in fact, such spectacles had existed for many years, and Philips in France was very involved in the production and installation of the equipment. Articles in the *International Lighting Review* described installations for sound-and-light spectacles, and Kalff must have been well informed about them, since the magazine's chief editor was Johan Jansen (1910–2002), one of his staff members in the lighting advice office. In 1956, Kalff himself referred to the pavilion project as a “demonstration *son et lumière*” in a telegram to Le Corbusier.<sup>23</sup> In a 1959 lecture at Sarah Lawrence College entitled “Spatial Music,” Varèse also described his *Le poème électronique* as “the musical part of a spectacle of sound and light.”<sup>24</sup>

According to a 1960s Philips brochure, the idea for *son et lumière* was born when a man saw a castle in France stand out against the night sky as it was lit by a flash of lightning. In that split second, he saw the castle come to life, transformed from mere cold stone into a glowing entity. He immediately thought about how this dramatic effect might be produced for the benefit of others. “So started a series of Sound and Light Spectaculars that have grown in number and splendour amongst some of the world's most historic monuments, including churches, castles and even a World War II battleship.”<sup>25</sup>

The first *son et lumière* installation was made in 1952 for the famous spectacle at the château at Chambord, followed by others at Chenonceaux, Versailles and Villandry in 1953. In 1954, there were shows at Vincennes, Azay-le-Rideau, Grosbois, Bussac, Lisieux, Avignon and La Voûte Polignac. Attendance at these performances was enormous. The spectacle at Chenonceaux, for instance, drew weekend crowds averaging 2,000 per night, with a total of 150,000 visitors throughout the 1953 season.<sup>26</sup> To guide visitors to the various shows, Michelin even published a special road map, *Illuminations en France*.<sup>27</sup> Many new *son et lumière* spectacles followed throughout France in 1955, and during the months of the World's Fair in Brussels, shows were staged in Ghent and Laroche. Although these were not part of the Expo setup, they provided a major additional sightseeing attraction.<sup>28</sup>

The *International Lighting Review* of 1955 contained the article “Some General Rules for the Organization of



Fig. 2.21: The first “*son et lumière*” show at the Chambord chateau in 1952.

the Spectacles,” which described various technical details of sound-and-light installations. With regard to the audio, it stated:

Radio broadcasting technique has been applied to this new medium, supplemented by stereophonic effects (impression of depth) and movement in space (sound traveling), obtainable by means of double- or treble-track magnetophones and multiple points of emission. The loudspeakers are distributed over the whole building and surrounding areas. The audience must be able to hear, for instance, that a procession proceeds from one end of the building to the other. In Vincennes, for example, it always makes a vivid impression on the audience that they can follow the footsteps of the jailor as he enters from the left, strides through the whole length of the gallery and finally arrives at the tower chamber of the imprisoned king on the right. This effect is obtained by a gradual swelling and fading of the sound emitted by a row of loudspeakers erected along the gallery.<sup>29</sup>

Unlike the fully automated display at the Philips Pavilion, such spectacles were usually performed manually by two operators following a sequence script, one for the light and one for the sound. Since in most situations the operators were not able to observe the effects they created from their booths, it was essential that they could “play their instruments as a pair of practiced performers: otherwise the spectacle [would] make a mechanical impression on the public.”<sup>30</sup>

The image displays two pages of a technical script for a 'son et lumière' (sound and light) show at Chenonceaux Castle in 1953. The script is organized into columns for time, text, and technical instructions. The first page includes instructions such as 'passer H1.F2 sur secteur' and 'monter gradateur a 220V'. The second page includes '220/120V' and 'H.L.J'. Below the script are icons for 'Musique', 'Allumage', 'Extinction', '220/120V', and 'Sequences sonores'.

Fig. 2.22: Excerpt from a “son et lumière” sequence script for Chenonceaux Castle in 1953. Note the indication at point 14 for the “sequences sonores,” which are “traveling.”

By 1959, *son et lumière* spectacles had spread across Europe, with shows at Napoleon’s tomb in the Dôme des Invalides in central Paris, at the Sforza Castle in Milan, in the castle of Godfrey of Bouillon in Belgium, and at the Binnenhof, the seat of Dutch government, in The Hague. On May 29, 1959, one of the most famous sound and light spectacles premiered at

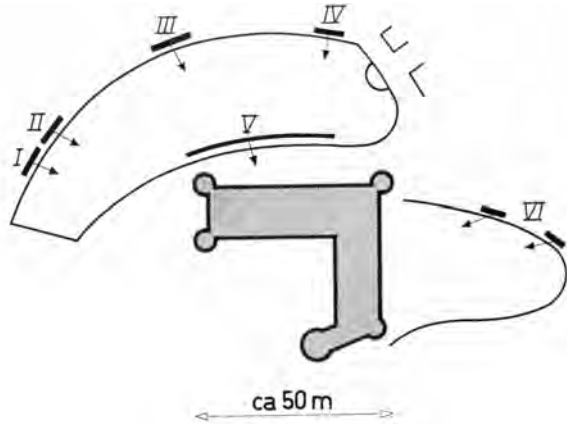

Fig. 2.23: Philips control desks for audio (left) and lighting. Fig. 2.24: Ground plan of light and sound installation for the 1954 spectacle “Les Féeries Nocturnes” at the château in Azay-le-Rideau.

the Acropolis in Athens. It is a good example of the immense scale of some of these shows: the installation, developed by the Société Anonyme Philips in Paris, used nearly hundred tons of materials, including 1,500 floodlights and a system for automatic switching between the different sound sources.<sup>31</sup>

These later *son et lumière* performances were automated, like the Philips Pavilion. Magnetic tape was used not only to play back sonic effects and music but also to reproduce control signals that replaced human operators.

On a smaller scale, mechanisms for synchronizing sound and light had been developed for museums in 1953 by the electronics manufacturer Etablissements Delauné in collaboration with Philips in France. A guide sent cues to the machinery by pushing a button in every room he or she entered with visitors. The installation played back explanatory texts and simultaneously switched the lights for the corresponding objects on and off.<sup>32</sup>

When Kalff wrote d’Aboville that he wanted to present a synthesis of light and sound in a completely new, modern form, with the walls bathed in light and color that would change to the rhythm of modern stereo music,<sup>33</sup> he was apparently not only artistically influenced by existing sound and light spectacles but also aware of the technical fact that Philips had the skills and equipment available to realize the project he had in mind. While *son et lumière* projects were created as extensions of existing architec-

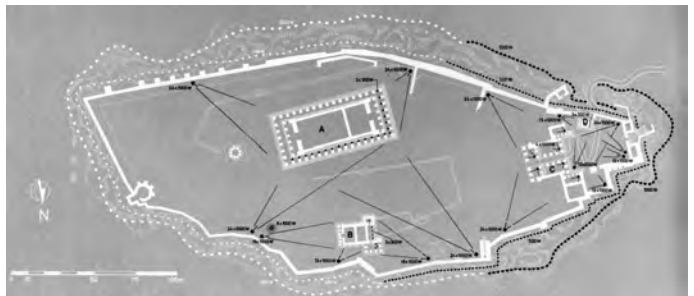

Fig. 2.25: Ground plan for the lighting system of the sound and light spectacle at the Acropolis in Athens.

ture, the Philips Pavilion was built out of the need for a container for *Le poème électronique*. Thus, the spectacle could be described as an “inside-out” *son et lumière* project.



*Fig. 2.26 and 2.27: Installation for automated playback of explanatory texts and light switching at the Palais Bénédicte, Fécamp, France (left); a museum guide giving a cue to the machine from one of the exhibition rooms.*

## Chapter 5

### Realizing the Music for the Philips Pavilion

#### Le Corbusier, Edgard Varèse, Iannis Xenakis: Artistic Considerations

On February 24, 1956, Kalff and d’Aboville visited Le Corbusier at his atelier in Paris. They extensively discussed the plans for a spatial demonstration of color, light and music at the World’s Fair in Brussels. Much to Kalff’s satisfaction, Le Corbusier was interested in these plans, although he didn’t seem to care much about the outward appearance of the building. The decision to work with Le Corbusier strongly influenced the further development of the Philips Pavilion project, which changed considerably from Kalff’s original plan. Le Corbusier wanted not only to design the interior but to be in charge of the whole pavilion, including the scenario for the images and light show. Furthermore, he insisted that Edgard Varèse be commissioned to compose the music instead of Britten.<sup>34</sup>



Le Corbusier had personal reasons for preferring Varèse. Once, when Xenakis (an architect in his studio since December 1947) mentioned Schoenberg, Bartók and Stravinsky, Le Corbusier replied, “Pompier.”<sup>35</sup> Le Corbusier came from a musical family: his mother played the piano well, and his brother was a composer. But Le Corbusier himself had no talent for music. He had grown to hate the traditional music that surrounded him, including his brother’s. According to Xenakis, Le Corbusier admired Varèse for good reason. In the late 1920s, several painters and architects had discovered the beauty of raw materials such as stones and timber. For Le Corbusier, Varèse represented the same trend in music. So, according to Xenakis, Le Corbusier regarded Varèse as his spiritual kinsman.<sup>36</sup>

A note in one of his sketchbooks makes clear that Le Corbusier had already considered using Varèse’s music in 1951 in a film about his Unité d’Habitation building in Marseilles.<sup>37</sup> Subsequently, in a letter dated January 27, 1954, he asked Varèse to help create an electronic carillon based on “tape music” for the campanile at the chapel in Ronchamp.<sup>38</sup> Le Corbusier described to Varèse how musical elements would be recorded one after the other on wire or tape and function as a library of sounds. The broadcast director would then edit these segments. Le Corbusier imagined “beautiful fragments of ancient liturgical music set against a background of modern music, disrupted by violent or impersonal bursts [...] of modern music.”<sup>39</sup> In an interview, Le Corbusier said about the music for the chapel at Ronchamp:

I will be able to experiment with music above the sacristy. This music is going to be spectacular, with 12,000 people and amplifiers. I said to the pastor: Instead of having an old person behind an accordion... [Question:] Harmonium? [Answer:] Instead of such a horribly out-of-tune harmonium, you could have beautiful new church music composed for it, open air music. I was with Varèse in New York. I said: Compose a terrific piece for me for a full orchestra. If you feel like it – but no sad music. It has to be music with a lot of loud noise.<sup>40</sup>

Varèse did not ultimately compose music for the Unité d’Habitation film or the chapel at Ronchamp. But when one listens to *Le poème électronique* today, it is apparent that Le Corbusier’s fantasy of “beautiful fragments of ancient liturgical music set against a background of modern music, disrupted by violent or impersonal bursts” must have had an impact on the music Varèse eventually created for the Philips Pavilion.

Varèse had always propagated the use of electronics in music, but at the time Le Corbusier made the request for Ronchamp, he had finished only one composition that made use of electronic instruments (*Ecuatorial*, 1934). Although the two theremins (to be replaced by ondes Martenots in the second version) prescribed for the performance of *Ecuatorial* used electronic means to produce sound, their parts in the score were composed using traditional notation. But by the time Varèse finished the instrumental score of *Déserts* for twenty instruments at the end of 1952, he had obtained an Ampex model 401A tape recorder from his wife, Louise,

and his friend Alfred L. Copley (1910–1992), the painter and scientist.<sup>41</sup> This tool enabled him to compose in a way that had no connections to conventional music notation and instrumental performance practice. He began recording factory sounds and percussion, which later served as the raw material for the three interpolations of organized sound he inserted into the finished instrumental score of *Déserts*.<sup>42</sup> Varèse rejected the term *musique concrète* to describe his own music<sup>43</sup> but nevertheless accepted Pierre Schaeffer's invitation in early 1954 to come to Paris and work on the completion of these interpolations at the studios of the Groupe de Recherche de Musique Concrète. Varèse sailed to France in cabin 508 of the *Liberté*, leaving on September 29 and arriving in Le Havre on October 5.<sup>44</sup> He worked on the interpolations almost continuously until mid-November, assisted by Pierre Henry. *Déserts* premiered on December 2, 1954, at the Théâtre des Champs-Élysées, with Hermann Scherchen conducting the Orchestre National de l'ORTF; Henry was responsible for playing back the interpolations of organized sound; they were reproduced through two sets of speakers at opposite sides of the stage. The concert, at which *Déserts* was played between Mozart's Overture in B-Flat Major<sup>45</sup> and Tchaikovsky's *Symphonie Pathétique*, was broadcast live in stereo, at that time still a novelty in France.<sup>46</sup> To hear the concert in stereo at home, listeners needed two radio sets, since the program's left and right channels were broadcast on two different stations, France Inter and Chaîne Nationale.<sup>47</sup> (An experimental stereophonic broadcast using the same method had taken place in the Netherlands on June 15, 1946; see Chapter 1, 28–33.) The scandalous response *Déserts* met with from its Paris audience is well documented; a recording of the event is available on CD (though in mono).<sup>48</sup>

During his stay in Paris, Varèse met many fellow artists, including the composers André Jolivet (1905–1974) and Pierre Boulez (1925–2016), the poet and painter Henri Michaux (1899–1984), the sculptor Osip Zadkine, and the writer and politician André Malraux (1901–1976).<sup>49</sup> His presence in the city was also noted by Iannis Xenakis. Alongside his work as an architect, Xenakis developed his skill as a composer in Paris. He studied between 1951 and 1953 with Olivier Messiaen, who advised him to apply his knowledge of architecture and mathematics to music.<sup>50</sup> That advice led to his first major work: *Metastaseis* (1954), for forty-six string instruments, twelve wind instruments and three percussionists. He later used a strategy similar to that used in the composition of *Metastaseis* in his design of the Philips Pavilion, which he based on the same hyperbolic paraboloid shapes he used to give form to the masses of string glissandi in *Metastaseis*. Also in 1954, Xenakis was accepted as a member of Schaeffer's Groupe de Recherche de Musique Concrète. When Scherchen came to Paris for the rehearsals and performance of *Déserts*, Xenakis used the opportunity to contact him and show him the score of *Metastaseis*. Scherchen did not conduct the first performance of the work,<sup>51</sup> but he later invited Xenakis to attend his conferences in Gravesano and to publish articles in the *Gravesaner Blätter*.<sup>52</sup> On March 8, 1957, Scherchen premiered Xenakis' *Pithoprakta* with the Symphonieorchester des Bayerischen Rundfunks at the Festival Musica Viva in Munich.<sup>53</sup>

In Paris, Xenakis attended the rehearsals of *Déserts* but stayed at home the night of the premiere so he could tape the radio broadcast. After the concert, Varèse visited Xenakis to lis-

ten to the recording. Xenakis found the mixture of the music and the audience noise quite beautiful, but Varèse was disappointed.<sup>54</sup> The next day, Varèse took a plane to Hamburg, where *Déserts* was to be performed again, this time with Bruno Maderna as conductor and Stockhausen playing the tape parts. This time, the work was well received by the audience. After the performance in Hamburg, Varèse went back to Paris, where he continued to work on revisions of the interpolations with Henry. He returned to New York by ship on January 28, 1955.<sup>55</sup> Although Le Corbusier wrote to Varèse in his Paris hotel on January 6, 1955, asking him not to leave before they had dinner or lunch together,<sup>56</sup> there are no indications that they actually met at that time.<sup>57</sup> However, Le Corbusier must have heard of the scandal caused by the performance of *Déserts* in Paris, most likely directly from his colleague Xenakis.

Although Le Corbusier's efforts to collaborate with Varèse had not been successful so far, apparently the idea had not left his mind. On June 12, 1956, some months after his first contact with Kalff, Le Corbusier sent Varèse another request for a musical contribution, this time explaining the concept for the Philips project. Varèse answered on the 16th:

Your letter of the 12th arrived this morning – Thanks. Since you asked, I want to tell you right away that I think your project is magnificent and that I accept with the greatest pleasure the collaboration that you propose. [...] Like you and the Philips Company I'm interested only in creating "the most extraordinary thing possible."<sup>58</sup>

Le Corbusier made the first sketches for the Philips Pavilion in September 1956<sup>59</sup> and gave Xenakis the position of project architect immediately after.<sup>60</sup> From then on, Xenakis would be in charge of the design of the pavilion, while Le Corbusier would concentrate on the "electronic poem" to be performed inside. Le Corbusier wrote a letter to Kalff on September 14, 1956, telling him he had reached an agreement with Varèse. Whereas the independence of the visual and musical layers of *Le poème électronique* was often emphasized later on, this letter stated that Varèse would compose the music according to Le Corbusier's scenario for the visual elements:

I have obtained the agreement of Mr. Varèse for the creation of the musical score. I know him well and he is greatly appreciated, and I myself appreciate the seriousness and substance of his music. I would not want the musical score to have a "flashy" extremist appearance in any way. I am convinced that Mr. Varèse and I share a lot: not only our age, but also the experience we have in two different domains. [...]

To conduct or commission drawn or colored, graphic or photographic or pictorial themes, I do not need collaborators; that is my profession. As for the rest, I have Mr. Varèse; a man of my generation of high integrity, who is excited about working with you on this project. Here, in my studio, I have a designer

[Xenakis] who is an engineer on the one hand and an avant-garde musician on the other. He is quite skilled in the latest manifestations of *musique concrète* et cetera. He became one of Mr. Varèse's "hands," so to speak. Mr. Varèse will compose his music based on my scenario, in close contact with me. (I should mention that I come from a family of musicians, and since my childhood I have been immersed in that atmosphere).<sup>61</sup>

## Philips' Doubts about Edgard Varèse

A month later, Philips officially commissioned Le Corbusier to design the pavilion and a "démonstration son et lumière." Still, Le Corbusier's wish to replace Britten with Varèse met with reservations:

Regarding the musical accompaniment and sound, we have noted your desire to secure the cooperation of Mr. Varèse.

However, it should be understood that Mr. Varèse will take into account our desire for the public to appreciate the quality of our reproductions and will therefore incorporate symphonic passages in his score.<sup>62</sup>

At Philips, it was assumed that Varèse would deliver an instrumental score, to be recorded with an orchestra, conducted by a famous conductor. That Philips was not comfortable with Le Corbusier's choice of Varèse was indicated in an internal message of November 15, 1956, from H. J. R. G. Hartong, member of the board of directors, to Kalff:

Nevertheless, I don't understand anything of the music, which should be conducted by Evert Cornelis.<sup>63</sup> [...]

In my opinion, we must try to get an esteemed conductor – that is, if he wants to do it! – for example, Eduard van Beinum, or, after consulting Evert Cornelis, another conductor and orchestra.<sup>64</sup>

With Le Corbusier insisting on collaborating with Varèse, the company started to gather more information about him. E. B. W. Schuitema of Philips' Phonographic Industries looked up Varèse in *Grove's Dictionary of Music and Musicians* and *The Gramophone Shop Encyclopedia of Recorded Music* for 1948 and found descriptions of his work that worried him. He wrote to Kalff:

Enclosed I send you some facts about the composer Varèse, which show that the music he composes suits electronic instruments exclusively.<sup>65</sup> It is Mr. Cor-

nelis' opinion that if you were to commission this man to compose works of a symphonic nature, this could only lead to unsatisfactory results. Apart from that, the question would be whether he would accept such a commission at all. We have ordered existing phonograph records of his music [the American *Varèse Record* on EMS containing *Intégrales*, *Densité 21.5*, *Ionisation* and *Octandre* had just been rereleased in France on Éditions de la Boîte à Musique], and as soon as we have them in our possession, we will notify you of our judgment of the quality of these compositions.<sup>66</sup>

Kalff agreed that he might have made a mistake in assuming Varèse's music could be conducted by Cornelis and performed by the Berliner Philharmoniker or the Concertgebouw Orchestra, since Varèse was an "unknown man" and his music had an "experimental character." However, he did not think it was necessary to be concerned with such details at that point. According to Kalff, should Varèse turn out to be the wrong choice, it was still possible to put forward a man such as Badings<sup>67</sup> or Britten, after discussion with Le Corbusier.<sup>68</sup>

On November 29, 1956, Kalff explained his ideas about the Philips Pavilion again in a letter to Varèse. He wanted to have a meeting in Paris to discuss possibilities for the presentation design with Le Corbusier, Varèse, and Philips technicians responsible for sound, light and electronic automation.<sup>69</sup> But, under pressure from Cornelis and Schuitema, Philips' Phonographic Industries' musical experts, Kalff wrote to Le Corbusier the same day and expressed his concerns:

The information we have received until now about Mr. Varèse's works is not very comforting. It appears that more and more Mr. Varèse is concentrating on *musique concrète* and that he is thus avoiding all the traditional instruments and their compositions. This is just the thing that we are trying to avoid. Naturally, we wish to respect your desire to collaborate with Mr. Varèse but we always reserve the decision on this subject until we have heard the most recent works of Mr. Varèse on records. Thus, we wish to make the decision on this subject after our meeting with Mr. Varèse and you in Paris.<sup>70</sup>

It was Xenakis who wrote back to Kalff on December 3, 1956, in Varèse's defense:

Mr. Varèse has never composed music that is solely "concrete." His last work, *Déserts*, performed in Paris in December 1954, was written essentially for an orchestra of wind and percussion instruments, with only interventions of concrete music. And until now, he has always written for instruments. I myself think that music by Mr. Varèse is exactly the kind which would show to best advantage the electronic systems of the Philips Pavilion because it utilizes all

the registers and all the dynamics of each instrument which are not usually “sent” through ordinary broadcasting.<sup>71</sup>

On December 13, 1956, Varèse went to Paris, this time by plane. He had meetings with Le Corbusier and Xenakis on each of the next three days.<sup>72</sup> Obviously, by the time Kalff and Cornelis arrived at Le Corbusier’s studio on the 19th to discuss the project in detail, Le Corbusier, Xenakis and Varèse would have thoroughly prepared themselves to convince Kalff. Another meeting took place on the 20th, followed by a music listening session on the 21st that was attended by Varèse, Henry, Kalff, Xenakis and Le Corbusier. Varèse went back to New York on the 27th.<sup>73</sup> Kalff had indeed become convinced of Varèse’s quality, and he later reported on the meeting to Philips:

On the afternoon of December 19 we had a long conversation with the architect Le Corbusier and the composer Varèse from New York. Also present were Mr. Evert Cornelis from Baarn and Xenakis from the architect’s office. [...] We are beginning to understand that both the sound to be designed by Varèse as well as the pavilion and the scenario by Le Corbusier will indeed have the effect we are aiming for: Philips will give an avant-garde demonstration that surely will be one of the most remarkable events of the entire exhibition.<sup>74</sup>

At Le Corbusier’s request, Kalff went to Paris again on February 11, 1957, this time in the company of the acoustics expert Willem Tak and Simon Leo de Bruin (not to be confused with Jan de Bruyn) of Philips’ exhibition department, who knew all about problems of automation and projection. Kalff himself offered to answer all questions regarding color and light.<sup>75</sup> By now, the feasibility of Xenakis’ challenging pavilion design had been proven in tests on a scale model at the Netherlands Organisation for Applied Scientific Research in Delft,<sup>76</sup> and the first acoustical calculations had been made at Philips to estimate the capacity needed for the sound installation.<sup>77</sup> Three days later, Xenakis wrote Varèse to tell him he would definitely be receiving the commission to compose the music. There was no scenario for Le Corbusier’s visual parts yet, but Tak would design a test presentation that would allow tests to be run in Eindhoven by April. These would be attended by Le Corbusier and Xenakis.<sup>78</sup>

## **The Garage at Strijp III and Willem Tak’s Test Scenario**

Tak finished the test scenario mentioned in Xenakis’ letter to Varèse on February 7, 1957. So in addition to Kalff’s previous descriptions of the character of the Philips Pavilion, there was now a detailed description of an audiovisual demonstration, further indicating what the Philips company wanted. Apparently, the popular touch of the *son et lumière* shows was part of that.



And whereas Le Corbusier and Varèse would later agree to avoid a one-to-one relationship between the sounds and the images, the scenario by Tak is full of them.

Tak's scenario is interesting for another reason: for the first time, it states a clear intention of using electronic sounds next to instrumental ones. Several other elements that would appear in the final pavilion, such as the movement of sound along loudspeaker routes and the use of ultraviolet lighting effects, are also mentioned. On the other hand, there is a clear distinction between the walls and ceiling, whereas one of the features of Xenakis' design, based on hyperbolic paraboloids, was that the curved walls ended in several peaks, so that the building had no ceiling at all.

"A Scenario for the 1958 World's Fair Philips Pavilion, written in order to illustrate some acoustical possibilities and, although superficially, to get an impression of the acoustical demands."

*Scenario:* The hall is covered with a deep red glow, as a rumble sounds from underground. This rumble gradually transforms into a bass tone, which eventually concentrates at the lower part of wall A. On this wall, a film image appears above the sound. It is hazy at first, but then it increases in brightness. It contains the image of a plant growing at high speed, until it reaches a height of at least 8 meters. As the red light dissolves, the bass tone crossfades into other sounds, which become higher and higher in pitch. These sounds move up the wall with the growing plant. They make a very high, twinkling sound, which slowly crossfades into a sung chord as the film image dissolves. The singing voices form a melody with additional reverberation. With the use of uviol<sup>79</sup> and variable diaphragms, light is projected intermittently on various parts of the ceiling, where strange figures have been added with fluorescent paint. The diaphragms vary, with different speeds and dimensions, so that the figures grow from a center and shrink back towards this center. After a climax, the reverberated sound decays rather quickly and disappears towards the horizon in the direction of wall B. The uviol lights are dimmed in this direction too. On wall B, an illuminated relief appears, with lots of shadow effects. From this relief on wall B sounds a bassoon tone, followed by an echo with reverberation from the horizon in the direction of wall B. After several repetitions, the echo crossfades into a zooming sound, which approaches quickly and disappears via the ceiling at the opposite wall C. At equal speed, a figure made of light moves from the relief across the ceiling, ending in a film image on wall C showing the movement of single-celled organisms in color. During the projection one hears sounds of different timbres and pitches, alternating in flashes from all possible directions, synchronized with colored light flashes. After a while, the flashes of sound give

way to a sound that moves along the walls horizontally at a certain height above the floor. The light flashes that initially coincided with the sound directions gradually transform into more and more permanent light sources, until the walls and the ceiling are illuminated extremely brightly, with a distinct separation at the height of the traveling sound. The circle of sound now starts to rise stepwise, as the illumination below the sound line goes out, until a light source in the center puts the hall in twilight and the sound, rather weak now, reaches the highest point both in timbre and location. The light source in the center then starts to flicker and increases in brightness, while the sound reaches a climax with vibrato and increasing reverberation. All this ends abruptly. The normal illumination of the hall is accompanied by a signature tune.<sup>80</sup>

The test scenario was followed by a description of the necessary speaker arrangement, which would allow for two types of sound movements. One set of speakers would enable panning, as used in the *son et lumière* shows at Chenonceaux Castle in 1953, while a second would use discrete loudspeakers for each sound position, as opposed to creating a sense of movement through panning. The second option was still in an experimental phase and needed to be developed further before it could be applied in the Philips Pavilion. To create artificial reverberation, Tak envisioned a completely separate installation with a Vermeulen-like “ambiophonic” positioning of the loudspeakers.

*Loudspeaker setup:* In order to create the different sonic effects, we will have to use an exceptionally large number of loudspeakers. Many of these will be facing the audience directly. [...]

Special loudspeakers will be mounted for the reverberation, which will not be directed towards the audience but towards the ceiling. [...] The reverberation equipment with its associated loudspeakers should be considered a completely separate installation, of which only the level will be controlled by the other equipment.

The bottom loudspeakers will have to be mounted under the floor. [...] To produce the subterranean rumble, these loudspeakers will operate as one group. [...] Roughly estimated, these are fifty loudspeakers of twenty watts each, fed by a thousand-watt amplifier. [...]

The panoramic sound effect can be achieved in two different ways:

1. The loudspeakers along the route can be distributed in groups. Each group will be fed by an amplifier. The input potentiometers of these amplifiers will be coupled on an axis. Fade-outs and fade-ins will follow each other. The stereophonic effect will be perceived well, provided that the listeners are not too close to the loudspeakers.

2. In order to obtain moving sound, it is also possible to use a rotary switch at the output of an amplifier. Each loudspeaker on the route along which the sound will travel will be connected to one contact of the rotary switch. The sliding contact will need to activate at least four speakers simultaneously in order to have sufficient power. This will make the stereophonic effect accurately perceivable for everyone. Therefore, this second method is preferable for some effects.

Depending on the effects in the scenario, the grouping of the different loudspeakers will be achieved by means of relays controlled by a number of control tracks, which will run in sync with the audio tape. [...]

It is very important that the hall be acoustically prepared in such a way that the reverberation time is almost negligible. Only then will the sonic effects be shown to their full advantage. Therefore, the walls and ceiling of the hall will have to be covered with sound-absorbing material for low and high frequencies. [...]

The above makes it clear that for the experiment to succeed, it is of the utmost importance that the effects in the scenario be thoroughly understood at the stage of designing the building.<sup>81</sup>

When Tak finished his test scenario, the pavilion in Brussels was far from ready. It would be nearly three months before the first pile was driven into the ground.



*Fig. 2.28 and 2.29: Brussels, May 6, 1957. The first pile for the Philips Pavilion being driven into the ground during a hailstorm (left); Kalff showing a scale model to Charles Spaens, Philips Belgium's deputy manager.*



*Fig. 2.30: The Philips garage at Strijp III. On the left is a curved surface for experimenting with the projection of colored light and one of two full-range loudspeaker cabinets. In the rear right corner is the temporary cabin housing the studio where Varèse and others would work. At the front on the right is the scale model of the pavilion. And mounted on panels on the walls at left and right are speakers for testing sound routes.*

As Tak wrote, it was of the utmost importance that the effects in his scenario be understood before the pavilion was built. A garage at Philips' Strijp III<sup>82</sup> complex in Eindhoven was therefore cleared so that it could serve as a testing ground for the audio installation, the projection of colored lights and film images, and the automation equipment. This garage was just one kilometer away from Philips Research Laboratories, but Vermeulen and his acoustics department were not involved in the testing at all.<sup>83</sup> According to Wiel Cox (\*1935), an ELA employee who began working in the garage by the end of March 1957 and would later work in the control room of the Philips Pavilion, the garage was the exclusive domain of ELA and the exhibition department at the time of the experiments.<sup>84</sup> One of Cox's first tasks for his supervisor, Simon Leo de Bruin, had to do with Tak's test scenario: he had to hang loudspeakers for the sound route experiments on the wall. Cox remembered that once the sound route was installed, De Bruin immediately tested it using a recording of Tchaikovsky's *Nutcracker Suite*.<sup>85</sup>

On April 2, 1957, Kalff mentioned the garage at Strijp III in correspondence for the first time, in a letter to Le Corbusier:

We are currently installing a space in a hangar in Eindhoven in which we will test the sound and light effects we find suitable for our pavilion during the next two months.

Meanwhile, we will complete a model, at a scale of 1:12.5, which will allow Mr. Tak to specify the positions of the loudspeakers. This scale model will allow us to examine not only the outside of the pavilion but also the inside. The scale model will be finished by the end of the week. We think it would be very useful if you and Mr. Xenakis would come over for a day to see the model and to answer some questions that came up while we were making it. You will then also see the exterior, with all the little domes that are necessary for the loudspeakers.<sup>86</sup> There will be more than 300. [...]

We would also like to have one of Mr. Varèse's phonograph records to use in our experiments. [...]

We could also use your presence in Eindhoven to shoot some film footage for a documentary about the construction of our pavilion.<sup>87</sup>

Le Corbusier had by now begun designing the structure for the visual elements of *Le poème électronique*. He wrote back to Kalff on the same day, saying he had the ingredients for the scenario and would create it spontaneously and immediately after the tests in Eindhoven were finished.<sup>88</sup> Le Corbusier and Xenakis flew to Eindhoven from Le Bourget on a Philips company plane on April 15, 1957, and were taken back to Paris the same afternoon. The day's schedule included a presentation of the scale model, a meeting with members of the board of directors, a discussion with experts (presumably Tak and De Bruin), and shooting of the film scenes, but no sound and light demonstrations.<sup>89</sup> The footage shot that day would later appear in the film *De bouw van het Philipspaviljoen* (Building the Philips Pavilion) (see fig. 2.31–36).

In parallel with the creation of the Philips Pavilion, Le Corbusier's studio was working on a large-scale commission in Chandigarh, India, which had started in 1951. Compared to the project in India, the pavilion was a relatively small assignment, and Le Corbusier only paid attention to it in between his frequent trips to Chandigarh. The building of the Punjab legislative assembly chamber, part of the job in India, was not completed until 1962.<sup>90</sup>

On April 23, 1957, Tak met Le Corbusier and Xenakis in Paris, mainly to discuss aspects of the acoustics of the assembly chamber in Chandigarh, but they also discussed the placement of the loudspeakers in the Philips Pavilion. Tak had calculated that for a good bass response, the domes planned to house the loudspeakers would need a capacity of ninety liters, but Le Corbusier found this size unacceptable from an aesthetic point of view. Xenakis therefore proposed reducing the capacity of the domes to a mere few liters and compensating for the relative lack of low frequencies with large speaker cabinets behind the partition walls that

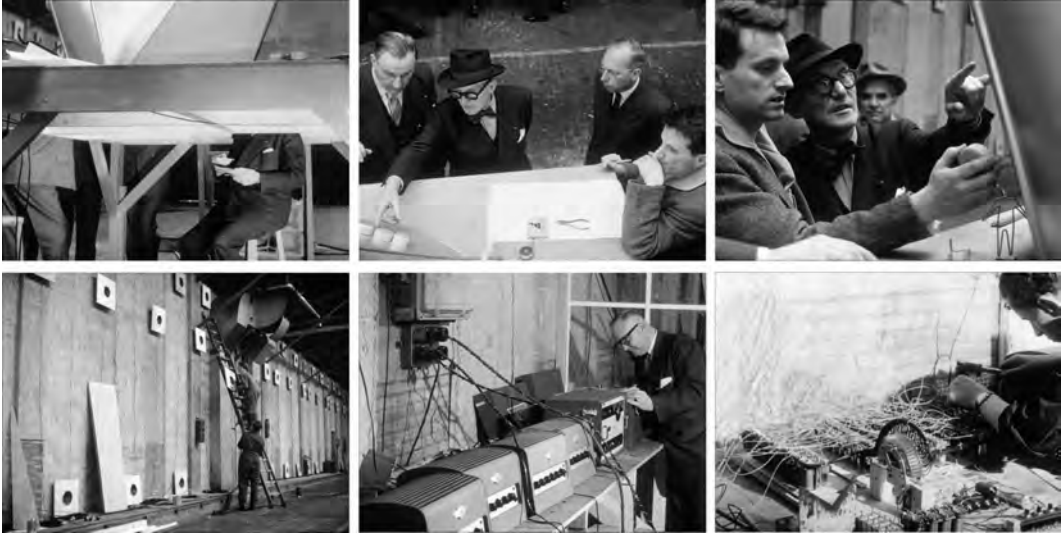

*Fig. 2.31: Le Corbusier looking at the interior of the scale model. Fig. 2.32 and 2.33: Kalff, Le Corbusier, Hoyte Duyster of the construction company Strabed, and Xenakis discussing placement of the loudspeaker domes. Fig. 2.34: Technicians hanging speakers for a sound route on the wall. Fig. 2.35: De Bruin at the tape recorder that controlled the rotary switches for the sound routes. Fig. 2.36: Wiel Cox soldering electronic connections for the sound routes. All images are stills from a film made on April 15, 1957, in Eindhoven.*

were to be put in place to hide the light projectors. Tak found this compromise too extreme, since the distance between the bass speakers and the small speakers in the peaks of the building would be too great from the listener's perspective. In the end, they decided not to mount loudspeaker domes on the exterior of the pavilion at all (openings would have been made to let the sound in). All the speakers would be mounted directly on the interior walls, and their cabinets would be as small as possible. In addition to the low-frequency speakers behind the partition walls, ten low-frequency cabinets, each with a capacity of four hundred liters and containing a Philips 9762/00 loudspeaker, would be placed on the walls near the peaks of the building. They discussed these new plans in Brussels on the following day with Hoyte Duyster (1907–1987), of the concrete construction company *Société de Travail en Béton* (Strabed), who was responsible for the actual building of Xenakis' challenging design. The advantages of the new plan were that Duyster could now decide on the shape and position of the concrete panels without taking the speaker domes into account, the new setup was cheaper, the team was free to choose the positions and spacing of the speakers on the sound routes, and the new solution would allow for corrections of the speakers' positions if Varèse's music required them later.<sup>91</sup>



## Edgard Varèse in Eindhoven and Preparations for Musical Production

In a report written on March 14, 1957, Kalff mentioned that Philips was considering having Varèse come over to record his composition completely in Eindhoven, perhaps during the months of May, June and July.<sup>92</sup> But in June, Varèse was still in New York. He wrote to Kalff on the 5th of that month:

I would like, if only mentally, to begin the sketches of the sound composition for the 1958 pavilion and, as you wrote me about last March, to be kept informed of the results of your experiences and sonic possibilities. It is also essential that I get the scenario as soon as possible, in order to know exactly what the requirements are.<sup>93</sup>

A first version of Le Corbusier's scenario, dated May 25, 1957, was sent to Varèse on June 22. It took the form of 27 *planches* (plates) with accompanying texts, each representing one of the "stations" of *Le poème électronique*. The colors and images were designed to take up the entire interior of the pavilion.<sup>94</sup>

Up to that point, Varèse had apparently planned to base the temporal structure of his music on Le Corbusier's scenario. But except for plate 19, which was supposed to be completely white and accompanied by silence, Le Corbusier now insisted that there be no correspondence whatsoever between the music and images. A month later, Varèse told Le Corbusier he agreed. Varèse had long been conscious that "the eye and the ear don't synchronize, because sound and light are essentially different. They should not confuse one another; rather, to be effective, they should be placed in opposition."<sup>95</sup> In a November 1958 radio interview, Varèse put it in simpler terms. The interviewer said, "Well, of course we do know that the eye and the ear don't synchronize." Varèse replied, "Well, Margery, exactly. It's like lightning and thunder: first you see the light, and then you hear the sound."<sup>96</sup> Nevertheless, Varèse later asked Le Corbusier again for an approximate indication of the durations of the sequences.<sup>97</sup>

By now, Varèse knew he would travel to Eindhoven and had begun sketching, combining and recording a number of structural fragments for electronic transformation.<sup>98</sup> Kalff had invited him to come to Eindhoven to witness demonstrations of sonic effects that Philips thought could be useful for his composition. After these demonstrations, Varèse would be able to stay in Eindhoven to work for a few weeks, perhaps a month. Kalff warned him, however, that the effects were not yet perfect, because the equipment was still in the experimental stage:

These are sonic effects in space, therefore effects of movement, direction, re-verboration and echo, which have never yet been used in electronic installations

Part II

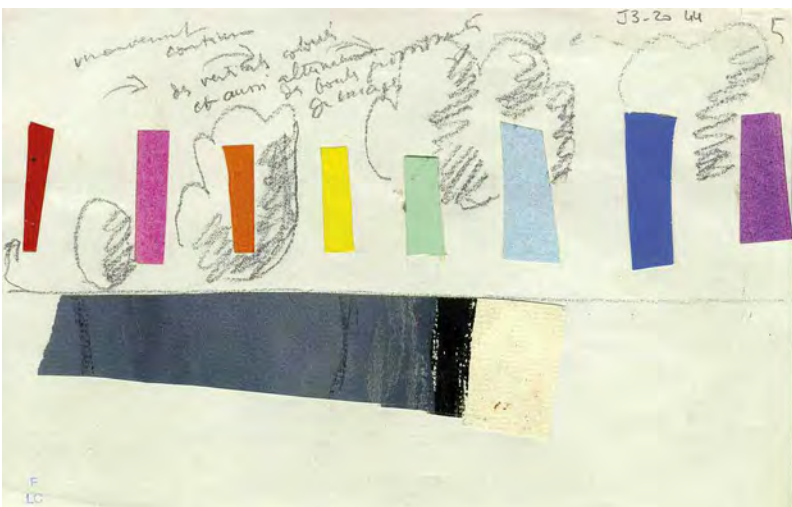
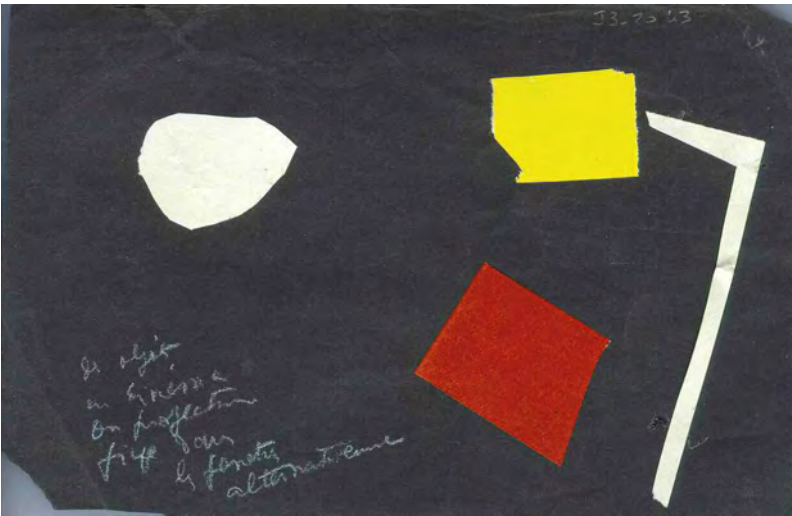
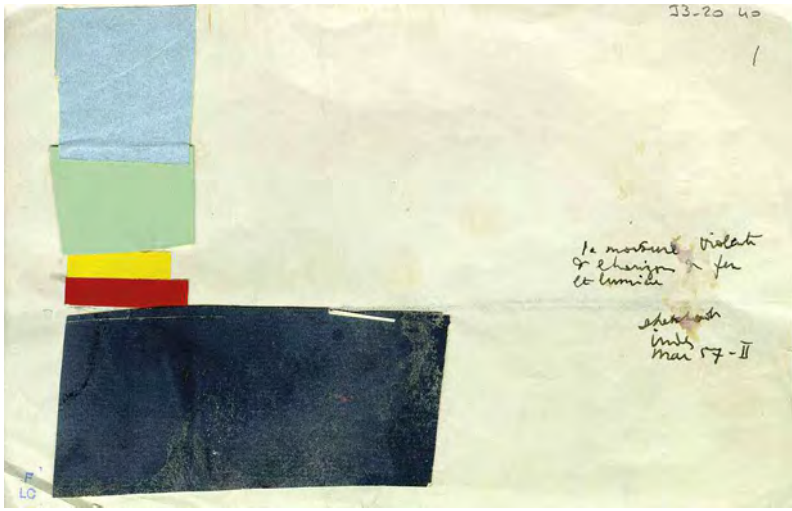

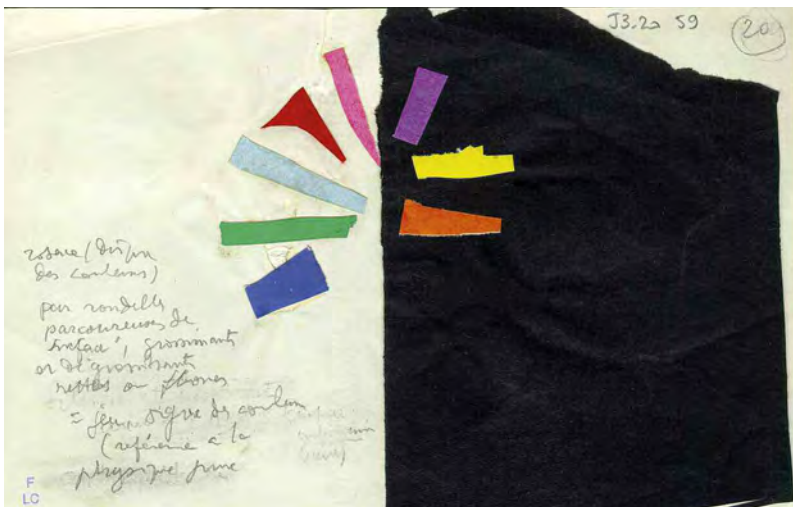
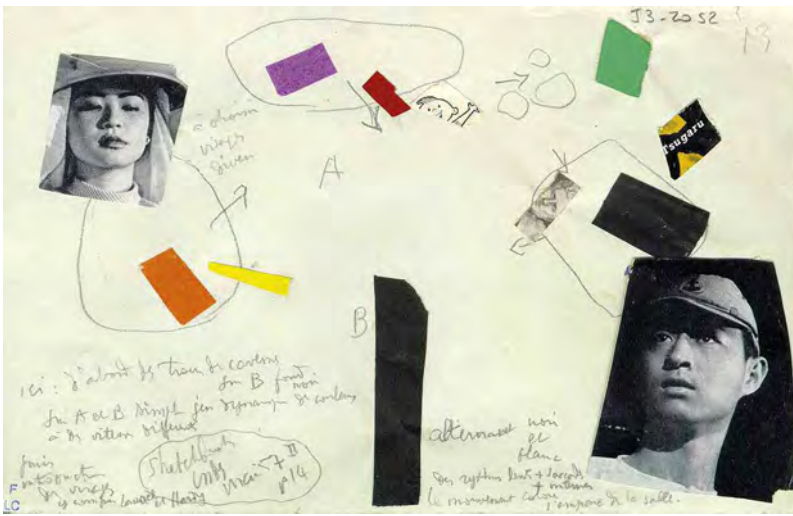
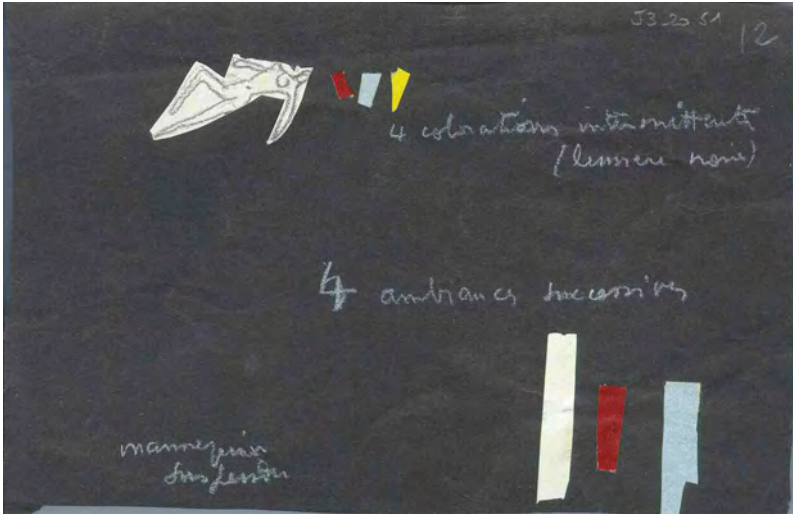

Fig. 2.37 to 2.42: Plates 1, 4, 5, 12, 13 and 20 of the first version of Le Corbusier's scenario for "Le poème électronique."

other than to accentuate the realism of music in concert halls and theaters, such as La Scala in Milan. If you are able to use these effects, we believe the demonstration [in the pavilion at the Expo] will be more interesting and new than it would be with only traditional automatic reproduction techniques.<sup>99</sup>

Apparently, Kalff didn't know that the electronic reverberation system he described had been used in the first performance of Badings' electronic composition *Kain en Abel* more than a year earlier at the Gebouw voor Kunsten en Wetenschappen in The Hague (see Chapter 3, 66-72).

On July 24, 1957, Le Corbusier and Xenakis took a flight from Paris to Brussels and then a helicopter to Eindhoven, where they were invited to witness the demonstration of light and sound effects.<sup>100</sup> Le Corbusier was obviously impressed with the results. He wrote Varèse five days later that he had witnessed demonstrations of sound, color and images in the Philips technicians' special hangar. He was pleased with his contacts there, Kalff and the acoustics expert Tak, particularly the latter. According to Le Corbusier, they were "great realists who had the respect of inventors," and he believed Varèse would be glad to meet them in Eindhoven.<sup>101</sup>

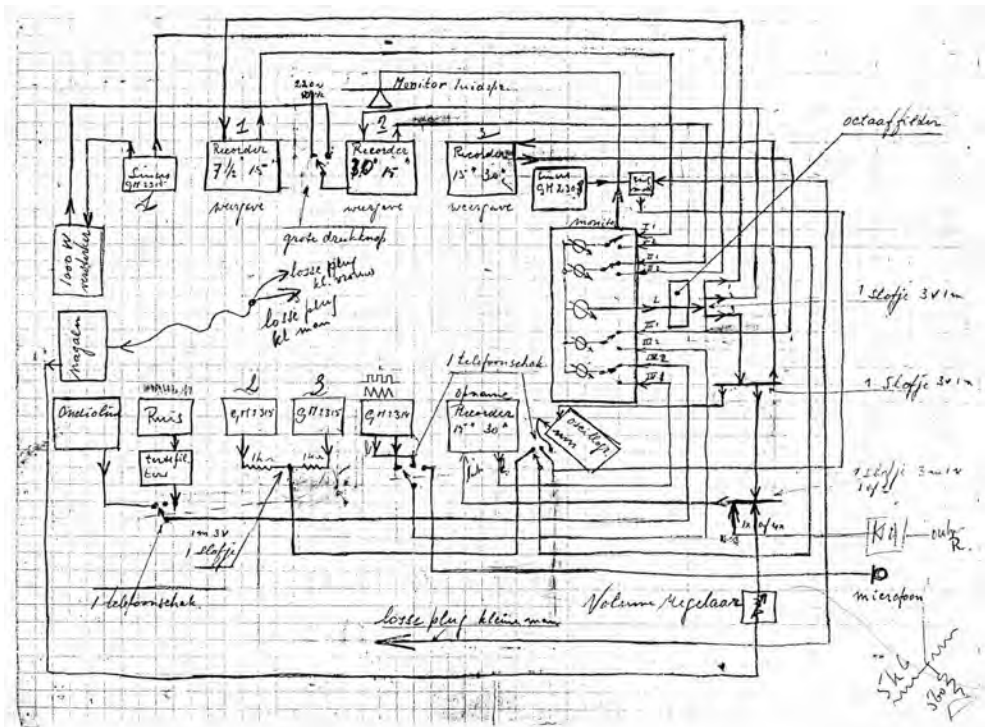

Fig. 2.43: Jan de Bruyn's design for the temporary electronic music studio at Strijp III.



Varèse and his wife, Louise, embarked on the Holland America Line's *Westerdam* on August 24 and arrived in Holland on September 2. Just before their arrival, they received a telegram through Scheveningen Radio that a double room with bath had been reserved in the Atlanta hotel in Eindhoven.<sup>102</sup> Possibly with the production speed of Badings' work at Philips Research Laboratories in mind (the 17'20" *Kain en Abel* took just seventeen days to produce), Philips assumed Varèse would finish production of the Philips Pavilion music in a few weeks, maybe a month,<sup>103</sup> with technical assistance from Tak and Jan de Bruyn. However, the work took much longer, and Varèse ended up staying until April 8, 1958.

After De Bruyn finished production of Badings' *Variations électroniques* at Philips Research Laboratories in August 1957 (see Chapter 3, 72–7), he was transferred to the ELA division to become Tak's assistant.<sup>104</sup> Tak was an expert in the field of acoustics but lacked the experience with electronic music production that De Bruyn had gained in his work with the NRU technician Arie Brandon for Badings. In advance of Varèse's arrival, De Bruyn had drawn up a design for a temporary electronic music studio and equipment list, largely based on the setup used so far in the production of Badings' works. Compared with other electronic music studios of the time, such as the one in Cologne, this setup could certainly be described as state-of-the-art. It included a Philips EL3800 mixing desk; at least four EL3509 tape recorders; a 1,000-watt EL6471 amplifier that, with a GM2315 sine wave generator, could control one of the recorders' tape speed; an EL6040 microphone; an EL6910 electronic reverberation system; a GM2308 sine wave generator; a GM2314 impulse/sawtooth generator; two more GM2315 sine wave generators; and a GM5659 oscilloscope. All were made available by the ELA division. Additional items, such as a ring modulator, an octave filter and three Wandel & Goltermann third-octave filters, were borrowed from Philips Research Laboratories. Philips' Phonographic Industries provided a special Philips stereophonic tape recorder.<sup>105</sup> According to De Bruyn's list, most of the borrowed equipment was to be returned to Philips Research by the end of September, but, much to Vermeulen's and Raaijmakers' displeasure, it stayed in the Strijp III garage until at least April 1958, due to the unforeseen duration of the realization of Varèse's music.

The first steps of the production of the music for *Le poème électronique* included:

1. The production of a number of tape loops, some based on Varèse's own material, others on sounds from, oscillators, and the rest on factory sounds.
2. Filtering of each tape loop in various ways and selection of the best results.
3. The one-track recording of a composition made up of these.
4. The selection of places in the composition where the sound would be highlighted through the use of the "dimensions" (various methods of spatialization).
5. The choice of the most suitable three-dimensional effect for each of the chosen sounds.
6. Creation of new multiple tracks by De Bruyn for the selected effects.<sup>106</sup>

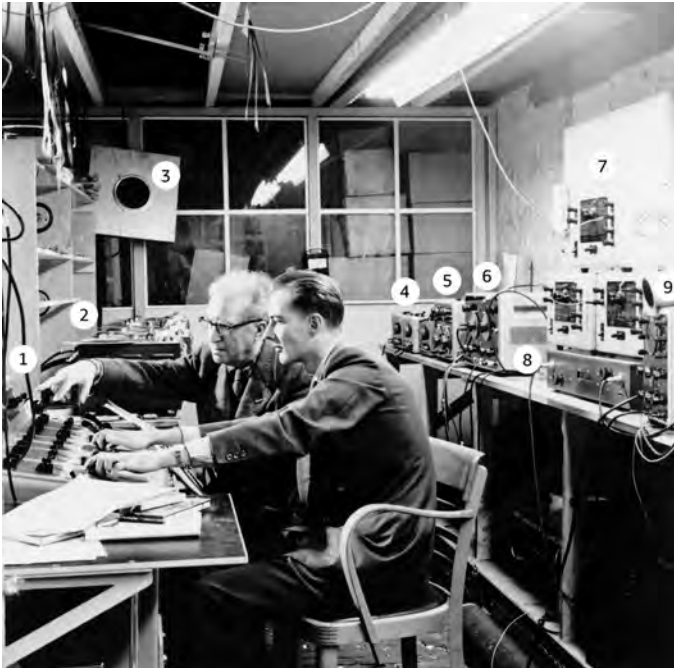

Fig. 2.44: Varèse and De Bruyn in the Strijp III electronic music studio with Philips EL3800 mixing desk (1); four Philips EL3509 tape recorders (2); Philips 9710M loudspeaker (3); three Philips GM2315 sine wave generators (4); Philips GM2308 sine wave generator (5); Philips GM2314 impulse/saw-tooth generator (6); three Wandel & Goltermann third-octave filters (7); Philips custom-built octave filter (8); and Philips GM5659 oscilloscope (9).



Fig. 2.45: Varèse and De Bruyn in the Strijp III electronic music studio, with Philips custom-built envelope generator/ring modulator (10) and Philips EL6040 microphone (11).



Although Tak later claimed that Varèse had mostly left the decisions regarding sonic spatialization of *Le poème électronique* to the Philips technicians,<sup>107</sup> Varèse inquired about the spatial possibilities of the intended system in the pavilion immediately on arrival in Eindhoven, before starting work on the music. The documents in the Varèse collection at the Paul Sacher Foundation in Basel concerning *Le poème électronique* include a number of pages of handwritten descriptions of the planned sound projection capabilities of the Philips Pavilion. These descriptions, written on stationery from the Atlanta hotel, where Varèse stayed for his first two weeks in the Netherlands,<sup>108</sup> have much in common with the loudspeaker plan attached to Tak's February 1957 test scenario; the handwriting is presumably his (it is certainly not Varèse's).

The loudspeaker system described would have consisted of speakers behind the partition walls and around the pavilion, giving no directional information, so the audience wouldn't be able to tell where they were located. These speakers would reproduce only frequencies between 20 Hz and 400 Hz. There would also be four hundred smaller speakers<sup>109</sup> scattered around the pavilion, mounted on the walls, with a frequency range from 400 Hz to 18,000 Hz. Above the entrance and exit, there would be two full-range "antiphonal" sources: large cabinets containing combinations of both types of speakers, capable of producing very high sound pressure levels. The various "acoustic scenes" were called "projections" and coded "Point A" through "Point F."



Fig. 2.46: A picture from a 1954 Philips brochure showing an identical Philips EL3800 mixing desk in the control room of the ELA demonstration studio (see fig. 2.44 (1)).

- Point A projection: Route du son – perspective of sound – very remote, far away, outside – coming closer and closer – at a certain moment its presence in the hall – suddenly runs any route – remain at a chosen point (entrance or exit) and from there goes out again fading out.
- Point B projection: A certain sound, very special – one route parallel differentiated – Mercurial effect, mysterious stereophonic effect – location purely individual and subjective – at a certain moment you feel the sound inside of you – slight pause – new projection (any one).
- Point C projection: Sound in the hall – impression of dimension of the hall – same sound in which reverberation is introduced and the dimension of the hall increases (expands) comes back to normal – finishes.
- Point D projection: Jumping of sound – jumping – independent of each other. Loudness restricted.

- ? Point E projection: Echo effect – mixed with jumping and reverberation – all combinations possible on the 3 tapes = any choice.
- ? Point F projection: Rain – a kind of falling counterpoint of the three tapes.<sup>110</sup>

To study the various types of spatialization in closer detail, Varèse used eleven drawings of the pavilion's stomach-shaped ground plan, which he had traced on transparent paper from drawings by Xenakis. He marked the paths of the sound with arrows and added annotations for each different spatialization method.<sup>111</sup>

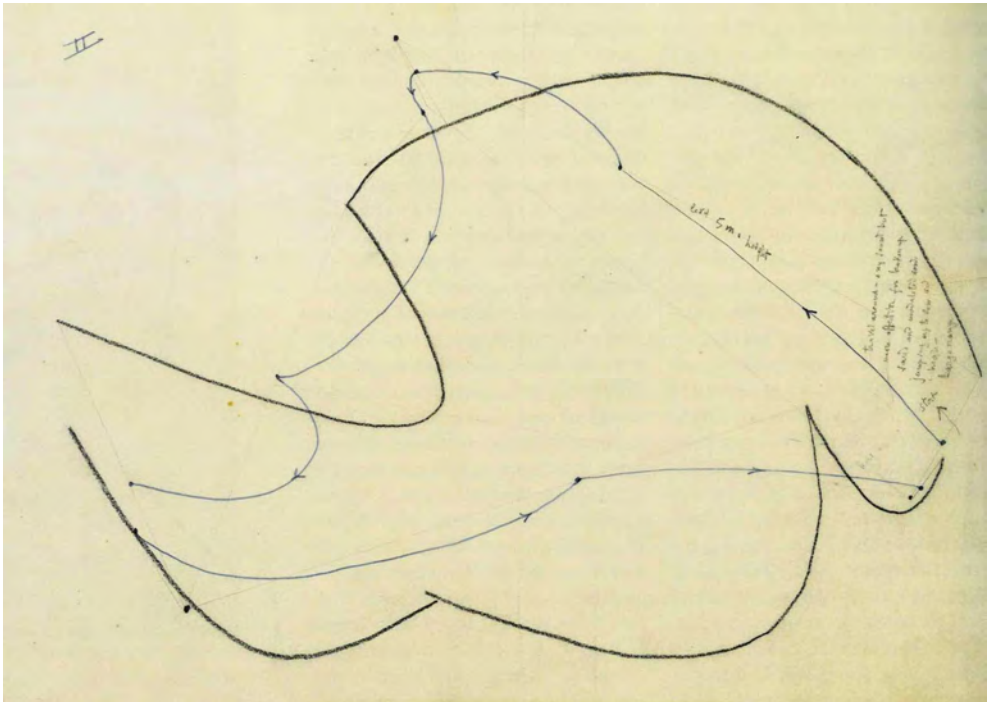

Fig. 2.47: Drawing no. II, showing one of eleven planned types of sound spatialization in the Philips Pavilion, with annotations by Varèse: "Level 5 m. height"; "Travel around – any sound but more effective for broken-up sound and modulated sound. Jumping up to low and high – large range."

These drawings show a strong connection with the sound projections points A through F but offer even more complex possibilities. There are, however, considerable differences between these plans for spatialization of the music in the Philips Pavilion and the eventual capabilities of the real sound system. Drawing V, for instance, shows two large speaker cabinets above the entrance and exit of the hall (the antiphonal sources), which the pavilion did not have in the end: they were replaced by clusters of small speaker cabinets mounted on the walls, probably for reasons of visual appearance. Drawing XI indicates the use of the electronic

reverberation system as part of the sound installation in the pavilion, but it was not installed in the end either. A decision was made to incorporate the reverberation effects in the three-channel sound recording instead of executing them in real time during the show.<sup>112</sup>

Photos of the garage in Eindhoven show that at least a number of these “projections” were tested while production of the music was taking place. Loudspeaker routes were mounted along the walls, the two large cabinets for the antiphonal sources were present, and the EL6910 reverberation system was also installed.



*Fig. 2.48 and 2.49: The two full-range loudspeaker cabinets acting as “antiphonal sources” in the front and rear of the garage at Strijp III and loudspeakers for a sound route on the wall. Photos by Anton Buczynski.*

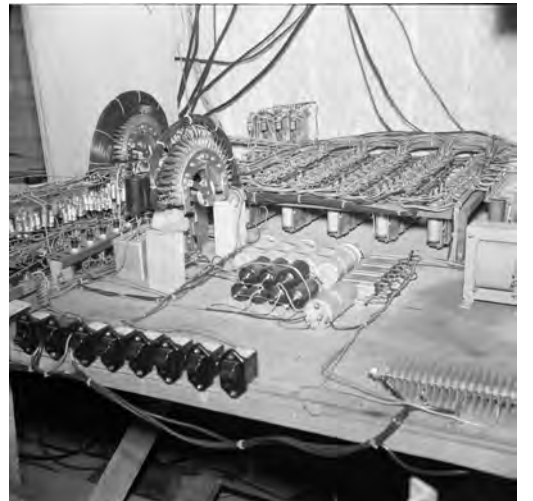
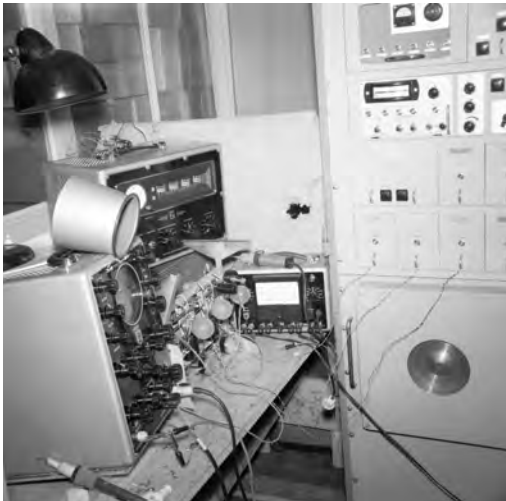

*Fig. 2.50 and 2.51: The EL6910 electronic reverberation system (left) and the rotary switch and relays for operating the experimental sound routes in the garage. Photos by Anton Buczynski.*

Other than the usual stress generated by a large-scale project with a clear deadline, everything seemed to be going well so far. But although Varèse had arrived on September 2 and was supposed to finish the music within a month at most, work did not start until the 18th.<sup>113</sup> In the meantime, on the 15th, Varèse and his wife moved from the Atlanta hotel to a small workers' house at Gagelstraat 38 in the "Philips village" area of Eindhoven.<sup>114</sup>

By now, the pavilion in Brussels was beginning to take shape. Concrete panels were moulded as separate units in Strabed's factory hall in Neder-Over-Heembeek outside Brussels and transported by truck to the building site. There, they were mounted on a wooden skeleton.



Fig. 2.52: Construction of the Philips Pavilion, August 28, 1957.

Xenakis wrote an article about the design of the Philips Pavilion, finishing it on July 9, 1957. It was published in issue IX of Scherchen's *Gravesaner Blätter* in October, some time before the building was finished. Just before publication of Xenakis' article, Hermann Scherchen asked Varèse to write about the production of the music for the pavilion as a follow-up.<sup>115</sup> Varèse replied that he couldn't, because Philips didn't yet want any details of the project to be given out.<sup>116</sup> Apparently, the company was still considering commissioning another composer, should Varèse's music be found unsuitable.



Meanwhile, in Paris, Le Corbusier had refused to credit Xenakis for the design of the pavilion. Without consulting Le Corbusier, Xenakis wrote a letter to Kalff to complain:

It is very painful to me to see that all my loyal efforts, to produce a Pavilion worthy of attention, have been completely ignored. As an example of my dedication with which I have worked on this project, I would remind you of the report I had submitted. This report suggested removing completely the concrete enclosures for the three hundred loudspeakers that Mr. Tak had recommended. In the end, you adopted my proposal, with which you saved several millions.<sup>117</sup>



2.53: A page from Le Corbusier's "minutage" for "Le poème électronique" of October 22, showing a circle depicting the overall structure of the seven sequences.

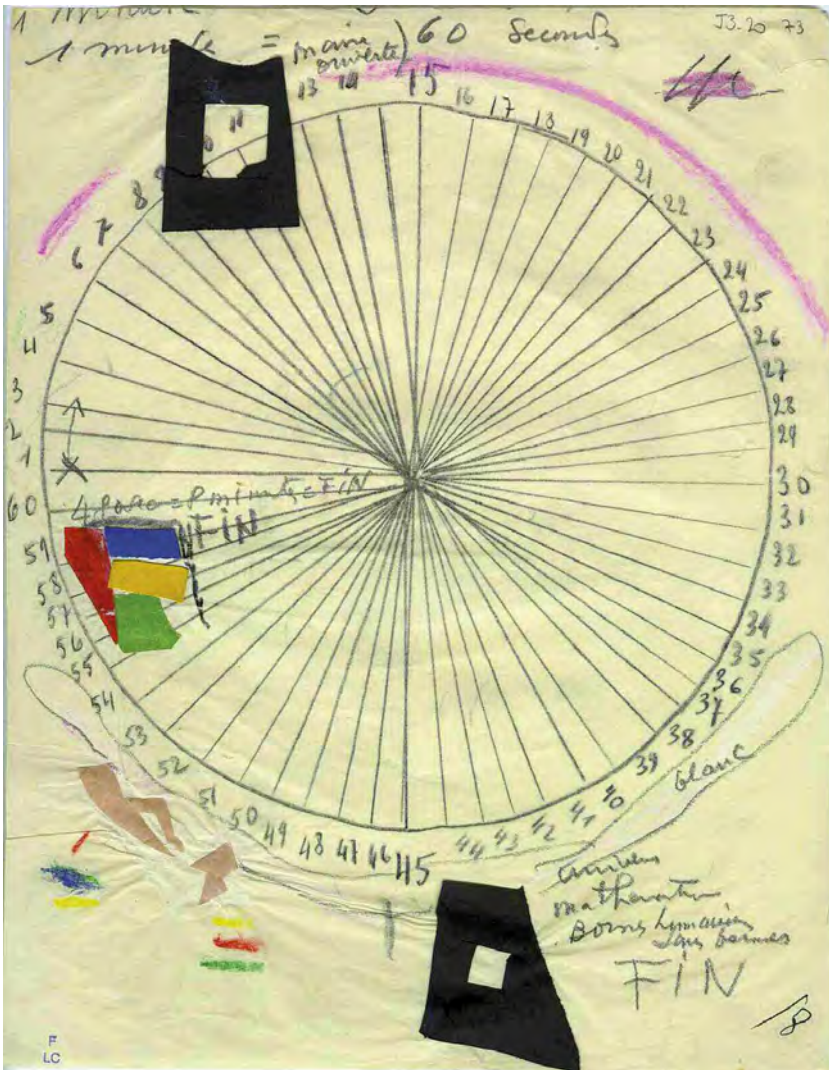

Fig. 2.54: A page from Le Corbusier's "minutage" for "Le poème électronique" of October 22, depicting the structure of sequence VII.

It was the beginning of Xenakis' gradual separation from Le Corbusier, which eventually resulted in his dismissal from the architect's studio at the end of August 1959.<sup>118</sup>

Although Le Corbusier had promised to create his scenario spontaneously and immediately after the July 24, 1957, tests in Eindhoven, the detailed version was not ready until October 22. The original structure depicted in the 27 plates in May had expanded, leading to a total of 42, grouped into seven "sequences." The overall structure did not change again; all the elements of *Le poème électronique* in its final form were there. The scenario, now called



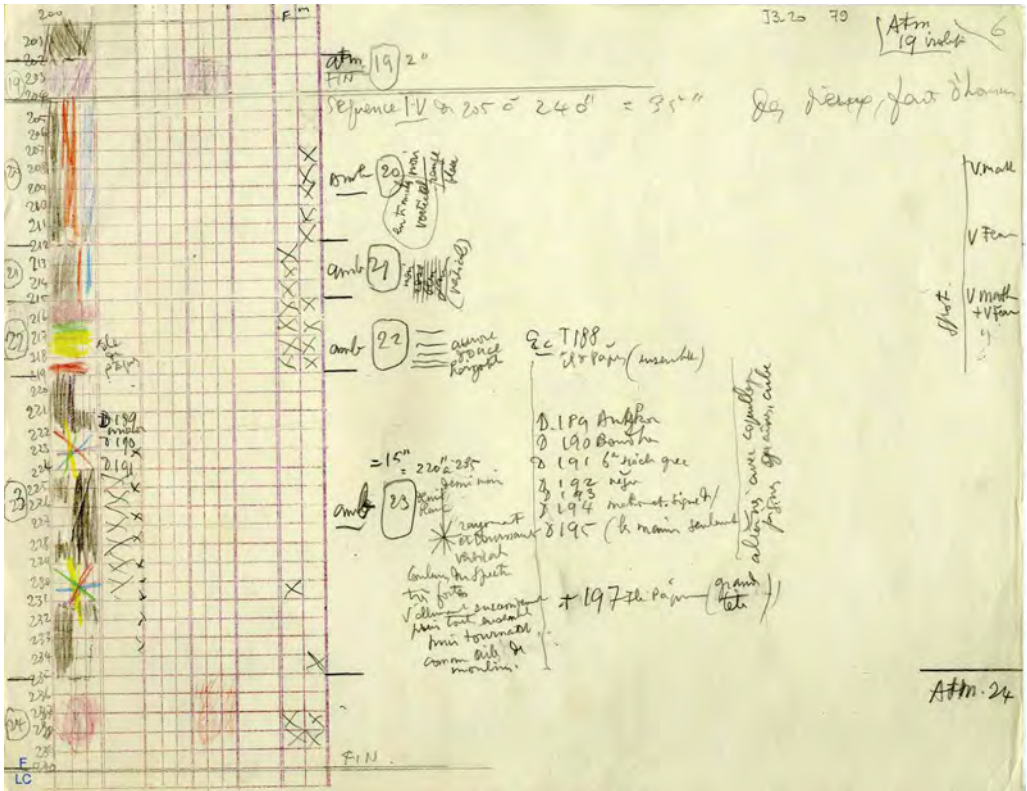

Fig. 2.55: Second-by-second table for scenes 19 to 24, lasting from 3'22" to 4'00".

the “minutage,” first visualizes the relative proportions of the seven sequences as parts of a full circle, emphasizing the sequential character of the work, which was meant to be performed almost continuously. The next seven pages describe the global structure of each of the seven sequences, again in circular form. After the circles, the manuscript contains tables providing a detailed second-by-second description of all the visual elements.

### The Laborious Recording of *Le poème électronique*

Between 1936 and 1946, Varèse had worked on a large-scale composition called *Espace*, a “symphony” for chorus and large orchestra, to which he had hoped to add several electronic instruments.<sup>119</sup> He had also planned to use loudspeakers in the auditorium to direct the movement of the instruments’ sounds in space.<sup>120</sup> The spatial design of *Espace* finally expanded from a sound projection in a single auditorium to a performance in a number of world capitals, heard around the globe in a live broadcast.<sup>121</sup> *Espace* never advanced beyond the sketch stage, but a short, instrumentally compromised version, *Étude pour espace*, was performed once in New York, on April 20, 1947, with the composer conducting the New Music Society.<sup>122</sup>

When Varèse came to the Netherlands, he brought several copies of handwritten excerpts from *Étude pour espace*, which he had compiled and arranged specially, often by distorting the words of the original text.<sup>123</sup> Chou Wen-chung (1923–2019), Varèse’s assistant at the time, recalled the preparation of various pieces of written music before Varèse traveled to the Netherlands; these included organ parts originally created for *Déserts* but not used in it, percussion excerpts from *Déserts*, and the excerpts from *Étude pour espace*, which used “Language of Intensities,” as Varèse called the material, since it had lost its literal meaning.<sup>124</sup> Recorded instrumental music had been part of Kalff’s original project concept from the beginning, and he had given the commission to Varèse on the condition that he include “symphonic passages.” In a letter to Eli Bomli, the program director of the Nederlandse Radio Unie (NRU), dated November 2, 1957, Kalff wrote:

I hereby send you Varèse’s score, as promised. To realize the piece, we would need to ask a choir (of around sixteen people) and a number of percussion players to participate.<sup>125</sup> Please let me know as soon as you can if and when this will be possible. We would appreciate it very much if you could also organize space for rehearsals.<sup>126</sup>

Recordings of the excerpts of the *Étude pour espace* were indeed made in one of the broadcast studios in Hilversum.<sup>127</sup> A copy of these recordings remained in Varèse’s possession and is now in the collection of the Paul Sacher Foundation in Basel.<sup>128</sup> The basic substance of the vocal and percussion parts of *Le poème électronique* from 3’38” to 4’40” and 7’00” to 7’11” can be traced back to these recordings. It has often been suggested that the alto voice at 3’38” sings “Oh God,”<sup>129</sup> which would make it appear to be no coincidence that exactly at that moment, images of the Easter Island statues were projected on the walls of the pavilion. However, the written excerpts of the *Étude pour espace* in “Language of Intensities” read as follows: “Hooga, hoobayai, goo yo yo ya oh, oo –, wha-o hoo.”<sup>130</sup> The section from 4’47” to 5’36” contains transposed, filtered and ring-modulated material from the same Hilversum recordings. Thus, a total of 122 seconds of the 8-minute *Le poème électronique* consists of material from *Étude pour espace*.

The excerpts from *Étude pour espace* play a more prominent role in an incomplete earlier version of *Le poème électronique*. In this version, the Hilversum recording is used between 4’41” and 5’15”, without being electronically transformed at all. It then reappears between 6’08” and 6’44”, with different combinations of the phrase “ataka out” filtered and transposed in various ways.<sup>131</sup>

One more vocal part in the final version of *Le poème* is based on an excerpt from *Étude pour espace*: the soprano solo from 6’45” to 7’02”. It was not recorded in Hilversum, however, but some months later in Eindhoven.<sup>132</sup> Dutch opera diva Cristina Deutekom (1931–2014) later said she had sung the solo because she was the only one around who could hit the very

high F notated in the score. She was still an unknown student at the Amsterdam conservatory at the time, and no one explained to her what the recording was for.<sup>133</sup>

On November 30, Varèse admitted to Xenakis that his work was progressing at the slowest possible rate.<sup>134</sup> Shortly after production of the music began, Varèse went for several days to Brussels, where he had been invited to take part in the festival *Décade de la musique nouvelle Américaine* (Ten days of contemporary American music).<sup>135</sup> The festival, organized by the Belgian composer Jacques Stehman (1912–1975), also featured works by the composers Samuel Barber, Leonard Bernstein, John Cage, Elliott Carter, Aaron Copland and Gian Carlo Menotti.<sup>136</sup> Another interruption of the work in Eindhoven came on November 5, when Varèse went to Paris for a few days.<sup>137</sup>

These interruptions were not the only reason for the slow progress of the production. Partly because of Varèse's technical inexperience, his working relationship with his technicians in Eindhoven became increasingly problematic. A first indication can be found in Varèse's date-book, which mentions, on December 16, 1957, "Les 2 Salauds" (The 2 Bastards). Apparently, these bastards were Tak and De Bruyn. Two days later, in a letter to his assistant Chou Wen-chung in New York, he complained about the engineer, whom he called "stubborn, ignorant and insensitive."

Already conditioned by the existing trash he thinks he's a composer. [...] He resurrects the obsolete background effects and other reverberation clichés as exploited by Disney [...]. I have had a fight on my hand since the beginning and a tough one and I have exploded several times outside the limits of diplomatic patience.<sup>138</sup>

Tak's test scenario had shown that he had specific ideas about the music for the pavilion. In a 1984 interview, Tak recalled that he had originally understood that he was supposed to compose with Varèse, rather than merely acting as his technician. He had prepared several "beautiful sounds" beforehand, but these were all rejected by Varèse.<sup>139</sup> Working with the constantly hesitating Varèse must have also been difficult for De Bruyn, who was used to Badings' pragmatism. Varèse would often approve results and then reject them the next day. Nevertheless, Tak and De Bruyn never stopped working until Varèse was completely satisfied,<sup>140</sup> and Varèse indicated that the work was turning out as he wanted.<sup>141</sup> This explains Tak's dilemma: he had his own ambition to "create," while at the same time he was willing to be cooperative.

Varèse's harsh letter to Wen-chung was followed by one to Xenakis three days later:

There is doubtless going to be something of an explosion. Messers Philips and [...] don't like a fragment of the composition that X... played to them. It's true that it was presented to them without much ceremony and with totally inad-

equate means. Verdict: no melody – no harmony. These gentlemen would apparently be happy to be rid of me, but I'm not accustomed to being pushed around [...]. The first part has already been recorded on the three tapes. The second is well on in the sketch stage. I have plenty of time, since the sound equipment [in the pavilion] is far from ready still.<sup>142</sup>

Louise Varèse (1890–1989), obviously supportive of her husband, wrote in her datebook at Christmas that according to Varèse, Philips wanted “to get rid of him” after hearing his music for *Le poème électronique*. There was “still no word from Kalf,” and the situation was depressing. “All work stopped over the holidays. Dutch discourtesy!”<sup>143</sup> By now, their stay in the Netherlands had lasted almost three months longer than expected. The next day, she wrote that there had been nothing but “waiting since September 2. *Sabotage!*”<sup>144</sup> Then, on New Year's Day: “And *still* in Eindhoven!”

However, soon after that, things took a positive turn. On January 6, 1958, she wrote: “Work wonderful – to hell with Philips.” And the next day: “V. came home today – [...] played tape 3½ minutes – great variety & mood – one haunting phrase.”<sup>145</sup> By January 9, the work continued to go well, in spite of the “willful resistance” of “young De Bruyn and his hypocritical boss with the hyena laugh, Tak,” and in spite of “continual interruptions in garage – telephone, coffee, conversations in *Dutch*.” Varèse was “spitting his teeth,” and the tension was exhausting.<sup>146</sup>



Fig. 2.56: Le Corbusier speaking to Kalf, Frits Philips, Spaens, Duyster, Casimir, Numann and Otten, February 6, 1958. Between Le Corbusier's hands, De Bruyn and Xenakis can be seen; Varèse (with beret) is in front of the film projector.

When De Bruyn and his wife later joined the Varèses for dinner in their temporary home on Gagelstraat, the suspicion of sabotage was confirmed: De Bruyn himself took a stand against Tak and admitted he had been following Tak's orders to oppose Varèse.<sup>147</sup>

Things suddenly seemed to have changed for the better on January 20, 1958, when a demonstration of part of Varèse's music was given in the Philips garage for Hartong and the other directors. Varèse talked to them and answered their questions, and the atmosphere afterwards was cordial.<sup>148</sup> When Tak came to have dinner with Varèse and his wife three days later, even he expressed enthusiasm about Varèse's work.<sup>149</sup> In spite of the courtesy and enthusiasm they had expressed towards Varèse after the demonstra-

tion, the directors of Philips were not thrilled with the music, but most of them thought they should postpone their verdict until the composition was completed. Most resoundingly opposed to the musical segment was Frits Philips, who considered “the sounds composed by Varèse as not representative of the ideals of Philips and the free Western world.”<sup>150</sup> Another demonstration, which was only one minute long but included a color projection and film along with the music, was given in the garage on February 6<sup>151</sup> in the presence of Le Corbusier, Xenakis, De Bruyn, Kalff, Frits Philips, Varèse, Casimir, Numann and others.

The next day, a similar test including the projection of images and colors was presumably conducted in the pavilion in Brussels, which was far from finished. Varèse, Le Corbusier and Xenakis had been “splashing in the mud, up to [their] ankles in dirty snow, numbed by the cold.” Inside the pavilion they had “suffered a counterpoint of glacial drafts and winds.” As a result, Le Corbusier and Varèse both caught a severe flu.<sup>152</sup>

On the 9th, Le Corbusier took the train from Paris to his house in Cap Martin on the south coast of France. On arrival, he had a fever of forty degrees Celsius and had to stay in bed for six days.<sup>153</sup> Varèse was sick too but kept working every day until the 13th.<sup>154</sup> However, on the 15th, his condition had become very bad. Several doctors were consulted, and he was diagnosed with bronchitis. He went back to the garage on February 27, but he subsequently had to stay home again from March 5 to 14. The aftereffects of the illness would trouble him for the rest of his life.<sup>155</sup>

The company – presumably after the demonstration that had made Frits Philips doubt whether the project would represent it appropriately at the World’s Fair – decided to secretly commission the production of a backup performance. This commission included not just substitute music but a complete audiovisual show, created by artists and technicians Philips had used in the past. The music for the backup performance was written by the French composer and conductor Henri Tomasi (1901–1971). Tomasi was respected in the Netherlands, notably



*Fig. 2.57: Xenakis, Kalff, Le Corbusier, Duyster and Spaens (among others).*



*Fig. 2.58: Varèse (left); Brussels, February 7, 1958.*

for his performances at the Holland Festival,<sup>156</sup> and he had composed music for a *son et lumière* spectacle in France.<sup>157</sup> Philips did not give the commission directly to Tomasi, however, but rather to Pierre Arnaud (\*1921), the director of the Diffusion Magnétique Sonore (DMS) studio in Paris. DMS had produced the *son et lumière* project at Grosbois in 1954<sup>158</sup> and had also been involved in developing the electromechanical equipment for the automated programming. Through *son et lumière*, it had developed close relationships with Philips in France. The studio was eventually bought by Philips Disques France on November 6, 1957.<sup>159</sup>

In the backup performance, Le Corbusier's visual elements were replaced with "projections spatiodynamiques" by Nicolas Schöffer.<sup>160</sup> Schöffer had designed the Spatiodynamic Tower for the 1956 International Building and Public Works Exhibition in Paris, and his robot *CYSP 1* had appeared in the January 1958 performance of Badings' *Geluid der Werkelijkheid*. Philips had supplied an "electronic brain" for each of these projects (see Chapter 3, 83–6).

### Anton Buczynski's Contribution

The commissioning of the backup show did not imply that Philips had given up on the creation of *Le poème électronique* by the original artists. Apparently, the new commission was only a safety net. At the end of January 1958, Philips decided to bring in a neutral player in Eindhoven: Anton Buczynski (1923–2005). Buczynski was an Austrian engineer who had started working for Philips in Vienna on October 6, 1952, at the Wiener Radiowerke AG (WIRAG). He had been involved in the development of the Philips 10039 magnetic tape recorder (see Chapter 2, 53–9), similar to the type that was now being sold by ELA as EL3505, 3507, 3509 and the type used in the production of *Le poème électronique*. Still in Vienna some years later, he was asked by Philips whether he had any musical education. Buczynski had in fact been a member of the Wiener Sängerknaben (Vienna Boys' Choir) until his voice broke. Not only could he read music well, he could read a full score. After a fourteen-day trial period, he was contracted as a recording engineer. The job involved not only the recording of classical music but also the development of specialized equipment. Sometime in early 1958, he was asked whether he would like to go to the Netherlands for a while to work as an "editor-recorder" for Varèse. Buczynski did not know who Varèse was and received no information as to why the company would need someone from Austria. Nonetheless, he arrived in Eindhoven on the evening of February 19, 1958.

Soon afterward, Tak played Buczynski a tape of a popular song whose melody had been made out of a dog's barks. The individual sounds were transposed with the variable speed of a tape recorder so that they would correspond to the pitches of the melody. A similar tape had been made with cat's meows.<sup>161</sup> Buczynski was under the impression that Varèse felt very isolated; this idea is confirmed by the notes in Louise Varèse's datebooks. It was obvious to Buczynski that Varèse was not getting along with De Bruyn and Tak, but he considered himself a guest, sent for from Vienna, and decided to stay out of the conflict. He was not fa-



miliar with Varèse's music and found it difficult to get used to. Their relationship was somewhat distant at first, partly because Buczynski's English wasn't very good. However, Buczynski, who had worked as a recording engineer in Italy on a regular basis, once cursed in Italian when something technical went wrong, assuming nobody would understand him. Varèse said, "Ah – lei parla Italiano!" (Ah – you speak Italian!)<sup>162</sup> From then on, they spoke Italian, which delighted Varèse. Now he could talk to Buczynski without Tak and De Bruyn understanding what they were saying, just as Tak and De Bruyn had often excluded him from conversation by speaking Dutch in his presence.

Buczynski remembered that when he arrived at the garage in Strijp III, there were individual sounds created by De Bruyn prior to his arrival but no edited musical structures. His job was to create such structures, along with recording new sounds. However, this account contradicts the fact that Louise Varèse had heard a complete 3½-minute piece of music on January 6. When one listens to the first 3½ to 4 minutes of the music in its final form, that section does indeed seem to be a closed formal unit. Apart from the bell that marks the beginning and reappears at 2'34", a metallic rasping sound between 0'44" and 0'50", some industrial sounds between 1'10" and 1'30" (some of them mixed with synthetic sounds) and between 2'14" and 2'16", and various percussion instru-



Fig. 2.59: From left, De Bruyn, Tak and Varèse, March 1958.  
Photo by Anton Buczynski.

ment sounds between 2'03" and 2'29", this whole section is built up entirely out of synthetic sounds made with oscillators. The segment from 3'40" to 4'40", meanwhile, consists exclusively of material from the Hilversum recording of the *Étude pour espace* excerpts. The aforementioned preliminary version of *Le poème électronique* is largely identical to the final version until 4'40", although it is even more dominated by oscillator sounds and filtered electronic noises. The most striking difference is that the break point at 4'40" is followed by a 35-second untransformed excerpt from *Étude pour espace* that does not appear in the final version. In the final version, this is exactly the point where the first new sound recorded by Buczynski appears. Since none of Buczynski's sounds appear in the preliminary version, it presumably already existed at the time of his arrival in Eindhoven on February 19.

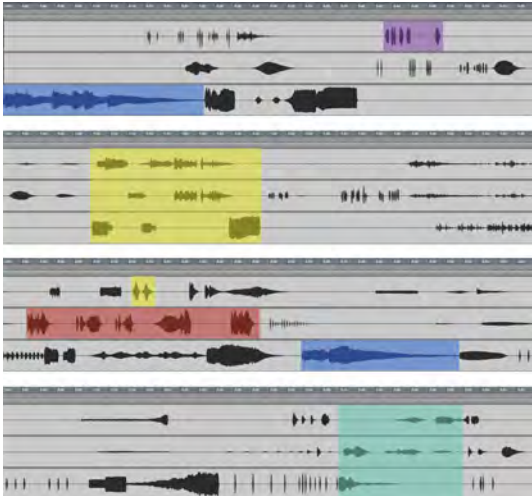

Fig. 2.60: The first four minutes of the three-channel master tape of “*Le poème électronique*.” Channel 1 is at the bottom, channel 2 in the middle, and channel 3 at the top. The bell sound is marked in blue, the metallic rasping sound in purple, the industrial sounds in yellow, the percussion sounds in red, and the “haunting phrase” from “*Étude pour espace*” (“*Hooga, hoobayai, goo yo yo ya oh, oo*”) in green. Diagram by author.

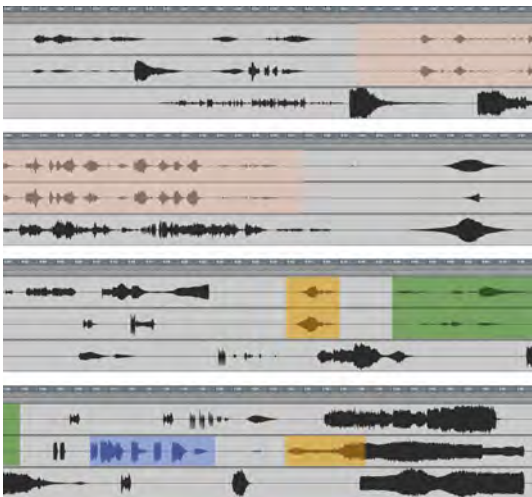

Fig. 2.61: The last four minutes of the three-channel master tape of “*Le poème électronique*,” with sounds recorded by Anton Buczynski indicated. The footsteps (mixed with electronic transformations from the “*Étude pour espace*” recording) are marked in pink, the fighter jet sounds in orange (the second one crossfades into the next sound), the soprano solo in green, and the organ sounds in pale blue. Channel 1 is at the bottom, channel 2 in the middle, and channel 3 at the top. Diagram by author.

The first recording Buczynski made for *Le poème électronique* was that of the simulated footsteps that appear from the break point at 4’40” until 5’34”. Varèse wanted footsteps, and Buczynski proposed using a trick he knew from radio plays: putting gravel into a wooden cigar box and shaking it. This did indeed produce the desired sonic effect. Varèse also wanted Buczynski to produce the sound of a fighter jet, which would seem to fly through the pavilion at the apotheosis of the piece. After various attempts to simulate this sound with a mixture of noise and a whistling tone, the men decided to try to record a real plane. Tak telephoned the commander of the Eindhoven air base and asked if a couple of fighter jets could make a nose-dive above Strijp III so their sound could be recorded. Tak and Buczynski were still putting the microphones on the roof of the garage when three jets arrived and made their dive. Tak made another phone call, explaining that they had come too early, but he was told it was impossible to repeat the flight because it would be too expensive. So the men decided to leave the microphones on the roof under a small shelter and wait until the wind direction forced the planes to fly over Strijp III before landing at the base. After a couple of days, they were indeed able to make the recording in this way. The sounds of the fighter jets appear in *Le poème électronique* from 6’32” to 6’38” and from 7’32” to 7’41”.

The aforementioned soprano solo in *Étude pour espace* was also recorded by Buczynski. A session was arranged with Cristina Deutekom in St. Catharina’s church in Eindhoven. Making microphone recordings in the Strijp III garage was problematic, because environ-

mental noise was always audible, and one had to wait for moments when there was no truck traffic. But acoustics probably also played a role in the decision to record in the church. Buczynski particularly remembered Varèse's wish to record the melody twice, with the second take exactly a semitone lower than the first one. The timing had to be precisely the same so that the two recordings could be synchronized later on. This was very difficult to achieve, but Buczynski succeeded. (However, in the final version of *Le poème électronique*, the recording of the soprano solo appears only as a single voice). The last recording made by Buczynski was of the organ chords (7'10"–7'24"), which Varèse had originally planned to use in *Déserts*.<sup>163</sup> The session took place on March 21, 1958<sup>164</sup> with the organ played by Hub. Houët (1915–1991), the chief organist at St. Catharina's since 1946.<sup>165</sup>

## **The Integration of Reverberation and Panning**

In the description of the setup inside the pavilion that was attached to his February 1957 test scenario, Tak said, "The reverberation equipment with its associated loudspeakers should be considered a completely separate installation, of which only the level will be controlled the other equipment." The loudspeakers of that separate installation would not point toward the listeners but would produce a diffuse, indirect sound. Furthermore, Tak made a clear distinction between two types of panoramic effects, one of which was based on amplitude panning.<sup>166</sup> "Fade-outs and fade-ins will follow each other. The stereophonic effect will be perceived well, provided that the listeners are not too close to the loudspeakers." The other method was based on the concept of sound routes, with the sound traveling through the space through the switching on and off of a long series of loudspeakers in succession. Whereas in the first method, the localization of the sound was strongly influenced by the listener's own position, in the second method, the sound would always be perceived as coming from the direction of the speakers that were actually producing the sound at that moment.

When Varèse arrived in Eindhoven in September 1957, Tak explained to him various types of "projections" (acoustic situations) that could be created in the pavilion. He described one of them as a "Mercurial effect, mysterious stereophonic effect – location purely individual and subjective – at a certain moment you feel the sound inside of you." This "Mercurial effect" was obviously based on the first method of panoramic sound movement. The next projection was described as a way to seemingly increase the dimensions of the hall and then bring them back to normal again. Tak later described the inside of the Philips Pavilion as giving the audience the illusion of sound sources moving around them while turning the acoustic space from a dry, narrow one into something like a cathedral.<sup>167</sup>

The original plan to include an electronic stereo reverberation system and additional circuitry for amplitude panning in the pavilion was finally abandoned, presumably for practical reasons. Instead, Buczynski was given the task of developing a way to integrate the desired



Fig. 2.62 and 2.63: Buczynski in the garage at Strijp III, moving a speaker attached to a rope in front of two microphones (left), and a speaker mounted on a panel with motor-controlled rotation in front of two microphones. Also visible in the right-hand photo is one of the full-range speaker cabinets representing the “antiphonal sources.” Fig. 2.62 made with Anton Buczynski’s camera; fig. 2.63 made by Anton Buczynski.

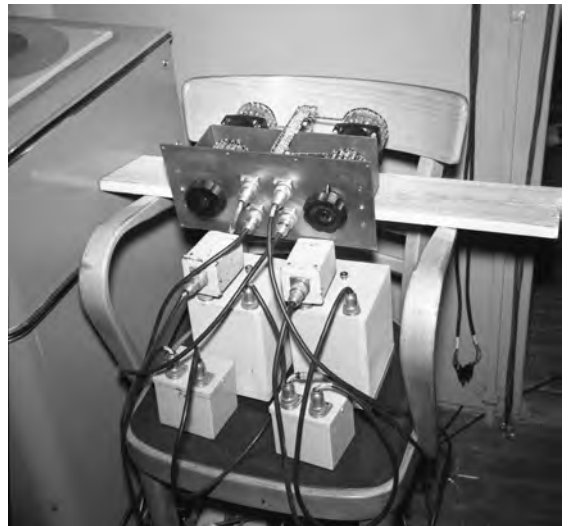

Fig. 2.64 and 2.65: Buczynski working on his electronic panorama control (left) and the connected device after it was completed. Just visible on the left in fig. 2.65 is the stereo tape recorder from Philips’ Phonographic Industries. Fig. 2.64 made with Anton Buczynski’s camera; fig. 2.65 made by Anton Buczynski.

panning and reverberation effects into the recording on the three-channel master tape. He first tried playing recorded sounds through rotating loudspeakers and picking up the move-

ment with two microphones.<sup>168</sup> Another experiment involved the opposite: recording a sound source in a fixed position with a rotating microphone. Buczynski finally obtained a more satisfying result when he designed and built an electronic circuit to replace the mechanical set-ups. The circuit was based on two large rotary switches that could control the panoramic movement of a sound; the level of the signal sent to the electronic reverberation system could also be varied. Buczynski recorded the resulting sounds on the stereo tape recorder borrowed from Philips' Phonographic Industries.

According to Tak's article in *Philips Technical Review*, the decision to play the music in the pavilion from a three-channel tape had been made at an early stage of development of the plans for the project. The simultaneous perception of three sound images coming from or moving in different directions was supposed to create "an entirely new experience."<sup>169</sup> The music for *Le poème électronique* was indeed recorded on three tracks, but first on three individual mono tape machines, each containing a single track.

Creating individual layers of a polyphonic musical structure on separate tapes was in fact the usual way of working in most electronic music studios, including the one at Philips Research Laboratories where De Bruyn had gained experience before becoming Varèse's assistant. Even in the studio in Cologne, where tape machines that could record four channels on a single 1-inch tape had become available in 1956, the method had remained common practice. The main reason was that the sound-producing equipment was only able to create one sound at a time. Sounds had to be recorded individually, edited, and then spliced together to form longer sequences before the layers could be combined. It was only in the final stage of production that these layers would be played simultaneously, on multiple tape machines, whose outputs were recorded on the separate tracks of the multichannel tape. This process was known as synchronization.

When *Le poème électronique* reached completion, it existed on three mono tapes that needed to be played simultaneously for the listener to hear the complete work. To enable these tapes to be played in sync, lead-in tape containing clicks and counts was spliced ahead of the actual music. As the lead-in tape played, the machines were manipulated, with the clicks and counts serving as audible reference points, so that more or less correct synchronization was obtained before the music started.<sup>170</sup>

With the original plan to install panning circuitry and a reverberation system abandoned, the stereophonic effects could not be applied in real time during playback of the three-channel master in the pavilion. These effects therefore had to be applied to some of the taped sounds in Eindhoven before final synchronization to the three-channel performance tape could be carried out.

According to a document from September 18, 1957, the first steps in the creation of the music had included the choice of points in the composition where the sounds should be highlighted using the "dimensions" and the choice of the most suitable three-dimensional effects for those sounds.<sup>171</sup> Before final synchronization, the selected sounds were removed from the



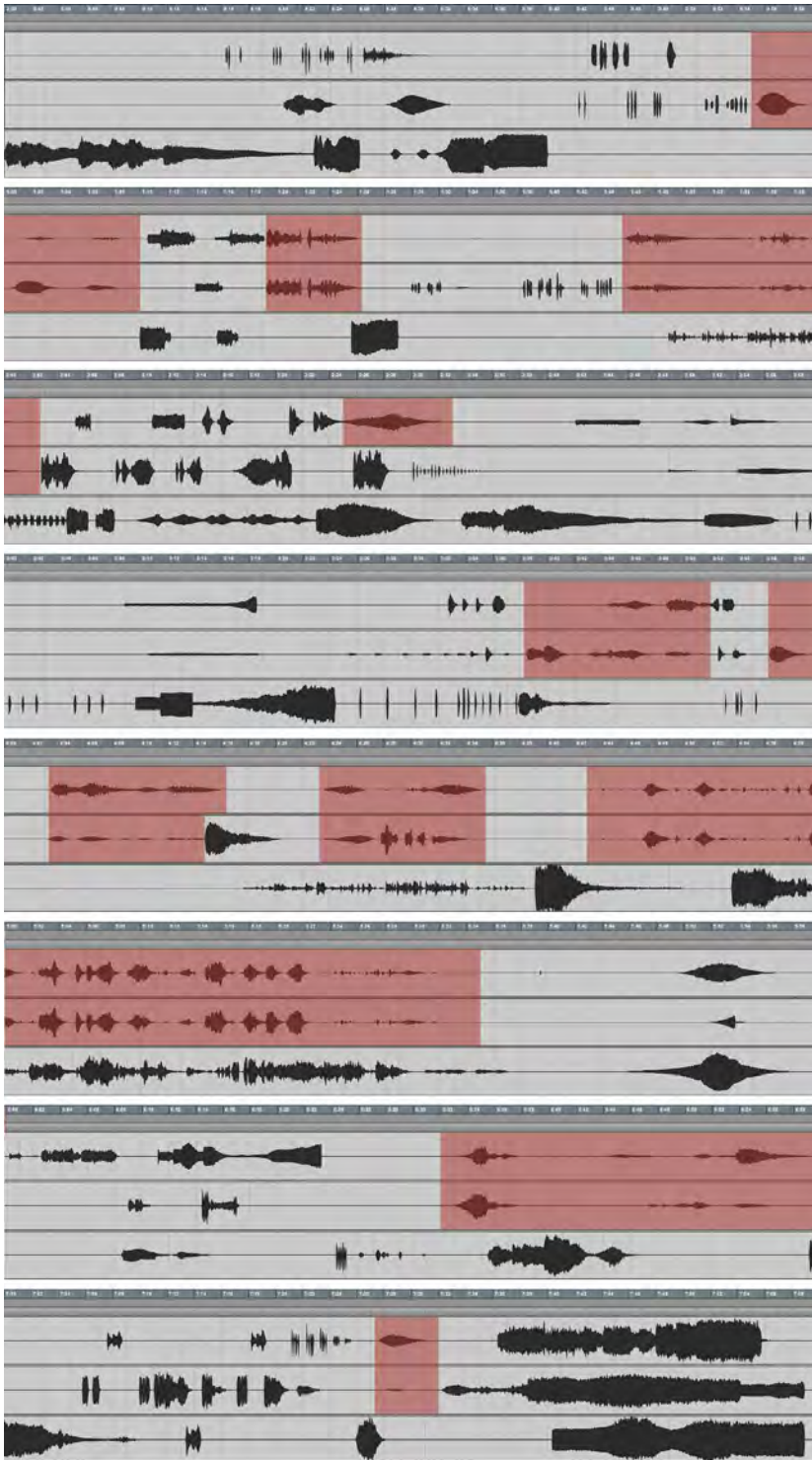

Fig. 2.66: Full overview of the three-channel master tape of "Le poème électronique." Sounds treated with stereophonic effects are marked in red. Channel 1 is at the bottom; 2 is in the middle, and 3 is at the top. Diagram by author.



mono tapes and replaced with equal lengths of blank tape. The sounds were then fed to the input of Buczynski's panorama control and the electronic reverberation system, and the stereophonic results were recorded on the stereo tape machine. These recordings were then spliced together with lengths of blank tape in such a way that the sounds would fall into their original positions when this tape was played along with the three mono tapes. As a result of this procedure, there were now four tapes that needed to be played simultaneously during final synchronization to the three-channel master tape. In that process, the left channel of the stereo tape was mixed with mono tape two, while the right channel of the stereo tape was mixed with mono tape three.



Fig. 2.67 and 2.68: The master tapes of "Le poème électronique" at the Institute of Sonology in The Hague: the three mono tapes and the stereo tape (left), recorded at 76.2 cm/sec, and the three-channel perfo master tape. The German handwriting on the boxes is Buczynski's. Photos by author.

The three-channel tape of the final mix of *Le poème électronique* was not a regular tape<sup>172</sup> but a perforated 35 mm tape. "Perfo tape" was used in the film industry, where the perforations allowed recorded sound to be mechanically synchronized with perforated film on a film editing desk. In the case of the Philips Pavilion, the perforations were necessary for synchronizing the music with the four projected films<sup>173</sup> and an additional perforated tape containing the control signals for the fully automated performance. The impressive-looking Philips EL3800 mixing desk from the ELA studio only had four inputs that could be mixed into one output, thereby making it unsuitable for final mixing of the music for *Le poème électronique*, for which five channels needed to be mixed into three outputs. A custom-built fader box was therefore used instead.

Surprisingly, Varèse and his wife left for Brussels, not to return to Eindhoven, before the final master tape of the music was produced. Buczynski therefore had to make the final perfo master with De Bruyn in Varèse's absence. Days before Varèse left for Brussels, Casimir and



*Fig. 2.69: Buczynski operating the three-channel performer and De Bruyn operating a custom-built fader box on top of the EL3800 mixing desk. Photo made with Anton Buczynski's camera.*

Vermeulen had arranged a two-hour visit for him to the Research Laboratories. Raaijmakers, who had the honor of giving him a guided tour, particularly remembered how impressed Varèse was when the electron microscope was demonstrated to him.<sup>174</sup> Louise Varèse wrote in her datebook that its images had reminded her husband of “modern painting ‘Fasciste’”<sup>175</sup>; he was probably referring to the Italian Futurist painting style.

Varèse also visited the acoustics department. He listened to Badings' electronic music, which was banal to his ears.<sup>176</sup> According to Louise Varèse, Vermeulen had expressed in somewhat impolite terms that he had decided to stay out of the Philips Pavilion project. She wrote: “Rivalries! Jealousies! We'll be out of it in 2 days!!!” When Raaijmakers was

asked much later to describe the relationship between ELA and the acoustics department, his immediate reply was: “one of rivalry.”

On April 8, 1958, at 7 o'clock in the morning, the Varèses left Eindhoven. Louise Varèse wrote in her date book: “Départ! Enfin!!” (Departure! At last!!) However, new problems awaited at the pavilion in Brussels, where the installation for playback of the music was still far from ready.



*2.70 and 2.71: The Philips electron microscope and an image of a zinc oxide crystal enlarged 32,000 times.*

## Iannis Xenakis' *Interlude sonore*

The eight minutes of *Le poème électronique* were embedded in a cyclical ten-minute program that was supposed to run almost continuously. The additional two minutes were reserved for an intermission, during which one audience would leave the pavilion and the next would enter. The music for this intermission was composed by Xenakis and resembles his later published work *Concret PH*. However, the title *Concret PH* did not appear once in correspondence relating to the design of the pavilion nor in the official credits. On the sign at the pavilion's entrance, the intermission music was called *Interlude sonore*. The same title is mentioned in the book *Le poème électronique*, edited by Jean Petit in 1958 and available for sale to the public at the pavilion.<sup>177</sup> The *Interlude sonore* that was played in the Philips Pavilion consists of three tracks and has a duration of 1'52", whereas *Concret PH* has two tracks and a duration of 2'45".<sup>178</sup>

Le Corbusier had mentioned Xenakis' intermission music in the letter of June 12, 1956, in which he asked Varèse to compose the music for the Philips Pavilion: "These two minutes of music I have entrusted to Xenakis (so that he should have a part in all this) and so that he can let loose the din of St. Polycarpus on all the devils."<sup>179</sup> Almost a year later, Xenakis complained to Hermann Scherchen that Le Corbusier had asked him to compose some "chansons à la [Maurice] Chevalier."<sup>180</sup> From the instructions for the intermission music Le Corbusier gave Xenakis on November 27, 1957, one could indeed get the impression that he had little understanding of Xenakis' importance as a composer: "I have thought very seriously about your two minutes of music. What is it about? [...] it is a sort of carnival hawking, in which it is possible to pack a lot of wit and content that can touch a crowd that by definition is inattentive."<sup>181</sup> In addition to this description, the letter included a firm refusal to Xenakis' request to leave the Paris office for three weeks to work on *Interlude sonore* in Eindhoven, where he would have been able to use the same advanced equipment Varèse was using for *Le poème électronique*: "It is impossible to go to Eindhoven for three weeks. Don't even dream about it! We have an architect's office here."<sup>182</sup>

Two days later, Le Corbusier sent Kalff a diagram of the intermission that contained a description of Xenakis' music, which is very close to the piece as it is known today: "Clouds of intermittent sounds, varying in density and intensity, and moving within the space of the pavilion."<sup>183</sup> On December 2, 1957, Xenakis wrote a letter to Kalff in which he self-confidently described the intermission music as "sober, striking and of an artistic quality at least as good as the rest of the spectacle."<sup>184</sup> Instead of using the studio in Eindhoven, as he had wished to, Xenakis was forced to use less advanced facilities. He was offered a chance to work in Pierre Arnaud's DMS studio in Paris, now owned by Philips Disques France<sup>185</sup> – the same studio where the secret backup show was being produced around the same time. Xenakis wrote to Kalff on March 11, 1958: "I started with Arnaud, who made a good impression. We recorded the sound of charcoal; it is very beautiful."<sup>186</sup> Arnaud later recalled Xenakis coming to DMS to record his composition, which had been completely calculated beforehand:

Xenakis had decided to record the sound of burning charcoal as the raw material for his music. But since its sound level was very low, we had to build a special amplifier for the occasion. After the sounds were recorded, they were spliced and combined according to Xenakis' calculations. Assembling the sounds was a difficult task, which was performed by the technician Georges Chottin. Five or six different small sounds, selected at random, were cut to specific centimeter lengths of tape. These little pieces of tape were spliced together in various combinations that were then mixed. The final result resembled the original recording, but with a remarkable difference: now everything had been calculated and a series of "coincidences" turned into a composition. The recording demanded a lot of ingenuity, and while we were making it, we almost set fire to the studio.<sup>187</sup>

In his letter to Kalff, Xenakis also explained his ideas regarding how *Interlude sonore* should be spatialized in the pavilion and asked whether these ideas could be put into practice. Presumably with the three-channel playback of Varèse's music in mind, Xenakis also planned to use three synchronized independent tracks. The sounds of these tracks would move along the "ceinture horizontale"<sup>188</sup> (horizontal belt), each at a different speed, two going clockwise and one counterclockwise. In addition, the three rotation speeds would not be constant but would change instantly and independently from time to time.<sup>189</sup>

Two days later, Kalff did his best to answer Xenakis' questions, but without having had the chance to discuss them first with Tak and De Bruin, who were both away. He said *Interlude sonore* would have to be played on a separate tape machine, since the tapes in the main system would have to be rewound during intermission. Xenakis would therefore have to limit himself to one track, but that track could move along the horizontal route at different speeds and start and stop at the places he wanted.<sup>190</sup> Xenakis, obviously disappointed, wrote back on March 17. With his letter, he enclosed an excerpt from his two-minute score for *Interlude sonore*, which he had conceived for three tracks with sounds moving at quite high rates of speed. He said he was disappointed to have to limit himself to one track but would adapt.<sup>191</sup> Kalff consulted Tak after his return, and a solution was found. Tak wrote that he was pleased to inform Xenakis that he would have three separate tracks at his disposal, and that he thought it would indeed be more fascinating if Xenakis' sounds were reproduced using all available possibilities.<sup>192</sup>

The stereophonic sonic effects, reverberations, disappearances, etc., as well as transfer with variable speed, octave filters, passing [sounds] through the impulse generator, etc., are possible. [...] I am, dear Xenakis, very pleased to be able to tell you this, and I hope to see you again soon to work together.<sup>193</sup>

Indiquer les directions de la ceinture

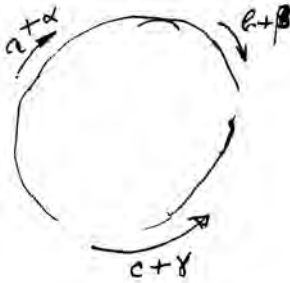

Fig. 2.72: Drawing from a March 11, 1958, letter from Xenakis to Kalfß explaining his idea for the spatialization of "Interlude sonore." Tracks *a* and *b* move clockwise at speeds  $\alpha$  and  $\beta$ , while track *c* moves counter-clockwise at speed  $\gamma$ .

Although Le Corbusier had forbidden Xenakis the previous November to leave his Paris architectural studio to work on the music for *Interlude sonore*, Tak now appeared to be inviting Xenakis to work with him in the studio in Eindhoven, using all the specific technologies available. Nevertheless, Xenakis completed *Interlude sonore* at the DMS studio in Paris. He sent the three tapes, along with a score for their spatialization, and expressed his gratitude for being allowed to use the "third dimension of sound."<sup>194</sup>

What he was referring to was the fact that, instead of all sounds being played over the (two-dimensional) horizontal route, they would now not only move horizontally, but could utilize sound routes that explored the vertical axis as well. They were spliced between the lead-in section with its clicks and counts and the beginning of Varèse's music, while Tak used the opportunity to reduce the length of Xenakis' tapes to the desired 1'52"<sup>195</sup> Xenakis was convinced that new effects would be created when his sounds were played in three dimensions. He had deliberately sought sounds that were unique but homogeneous in character, so that they would not "disrupt the richness of timbre used by Varèse." Thus, he had stayed in his "very secondary role." And should the use of the third dimension prove to be too disruptive, he could revert to using only the horizontal sound route.<sup>196</sup> What Xenakis did not mention, was the fact that his tapes and the accompanying score now had a duration of 2'45": 45 seconds longer than Le Corbusier and Philips had asked for.

After Xenakis' tapes arrived in Eindhoven, it took until the end of April before they were combined with the three mono tapes of *Le poème électronique*.<sup>197</sup> They were spliced between the lead-in section with its clicks and counts and the beginning of Varèse's music. The stereo tape was extended with a piece of blank tape of the same duration. When the final master perfo tape of *Le poème électronique* was mixed down, it included *Interlude sonore*, so that the whole ten-minute music program could be played from one single three-channel tape.

During the first 1'03", the three tracks of *Interlude sonore* are largely identical (apart from level differences), but slightly shifted in time. After 1'03", the sounds on tracks 2 and 3 suddenly become different from those on track 1, which continues with the same kind of material heard prior to the sudden change on tracks 2 and 3. Tracks 2 and 3 remain more or less identical up to the end of the interlude but are still shifted in time. *Interlude sonore* is followed by 8 seconds of silence, after which *Le poème électronique* begins.

As Xenakis had described in his letter to Kalff, *Interlude sonore* in many ways formed the perfect counterpart to Varèse's music for *Le poème électronique*. Whereas the character of Varèse's piece is defined by its wealth of different timbres and its fragmented counterpoint of successive and simultaneous "iconic" events (a characteristic it shares with the visual layers composed by Le Corbusier), Xenakis' music is highly homogeneous and continuous. While with Varèse, each single event has a clearly defined shape and duration, Xenakis' "events"



Fig. 2.73: From top to bottom: Track overviews of the three mono tapes and the left and right channels of the stereo tape. At the left are the last clicks for synchronization, followed by "Interlude sonore," then eight seconds of silence, and then the bell sound at the beginning of "Le poème électronique." The stereo tape is silent during "Interlude sonore." Diagram by author.



Fig. 2.74: Detail from fig. 2.73 showing slight time differences between the three tracks of "Interlude sonore." Diagram by author.



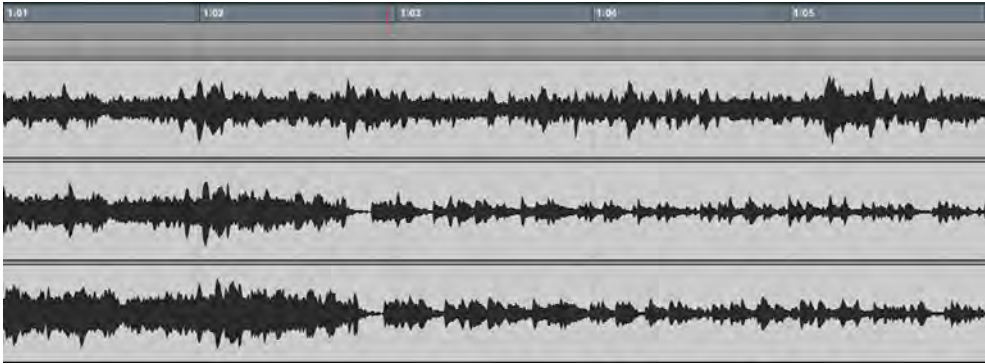

Fig. 2.75: Another detail from fig. 2.73 showing the sudden changes on tracks 2 and 3. Diagram by author.

are so small and closely connected that the music's identity is much more defined by the overall movement of the sound mass than by the appearance of the individual sounds they are constructed of. With regard to spatialization, the movements and positions of the individual sounds in Varèse's piece were defined only after they had been composed, whereas for Xenakis, the music's spatiality was already a designed aspect of the overall form of the composition at its conception.

## Chapter 6

### *Le poème électronique* in Brussels

#### The Sound Installation

Spatial reproduction of sound has become an important aspect of the concert presentation of electronic music, especially when there are no performers on stage. The Philips Pavilion was not only an early example of a sound spatialization system; it was a very ambitious one, even by today's standards. Nevertheless, during the production phase of *Le poème électronique*, for Xenakis, and to a lesser extent for Varèse, it remained a matter of guesswork how exactly the compositions would sound inside the pavilion. The sound system was at least as experimental as the music that would be performed on it, and it still wasn't operational when the World's Fair opened on April 17, 1958.

After Tak's aforementioned initial plan, the design of the sound installation for the Philips Pavilion underwent substantial modifications. The loudspeakers originally were to have dome-shaped ninety-liter cabinets visible on the exterior of the pavilion, but they ultimately had only very small cabinets mounted on the interior walls. The two large full-range cabinets that

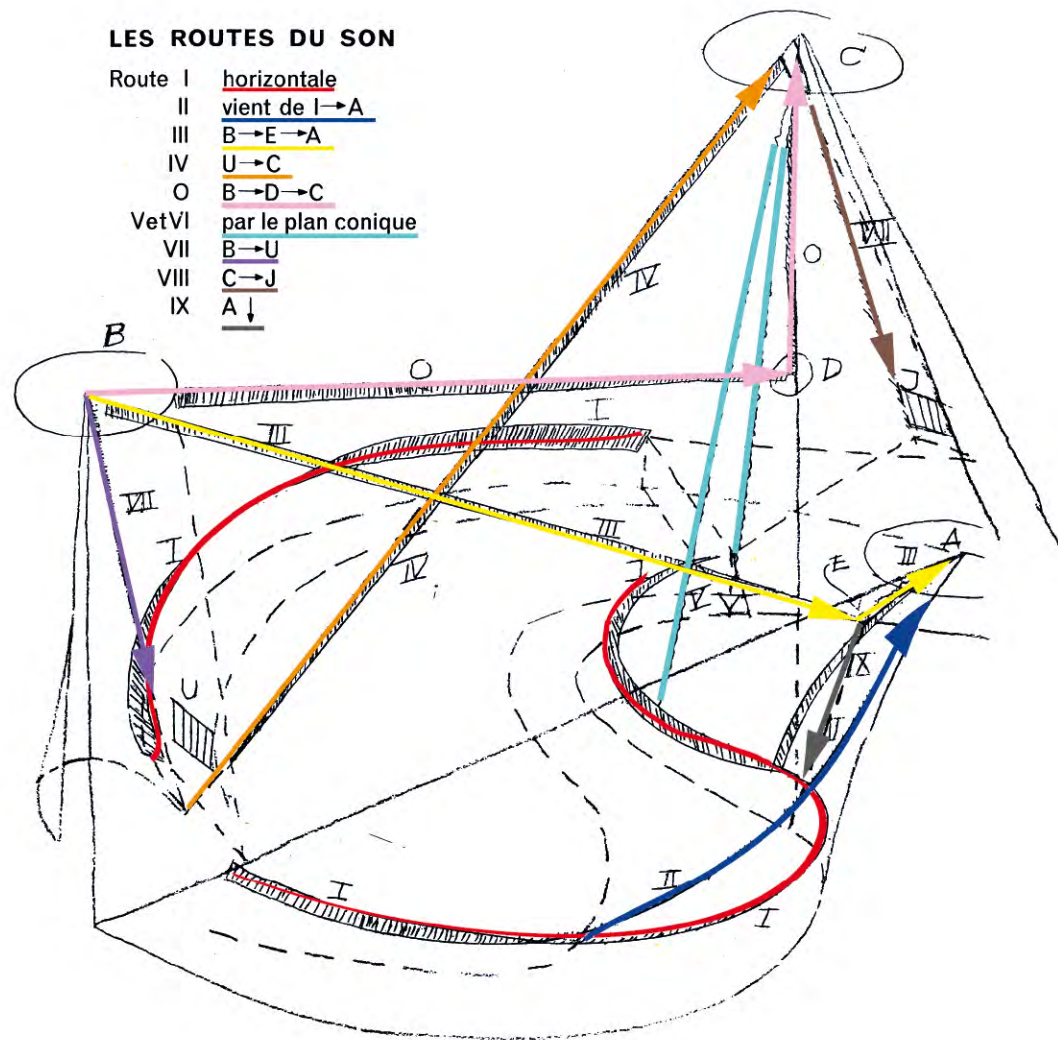

Fig. 2.76: Xenakis' design for the loudspeaker placement in the Philips Pavilion (colors added by author). It is somewhat confusing that he uses the term "plan conique" for sound routes V and VI, since conical surfaces had only been part of the design at a much earlier stage, and all of them had been replaced by "hypars" in December 1956.<sup>198</sup> Nevertheless, this drawing is identical to the final design of the building (see fig. 2.79–88 on pages 160–62).<sup>199</sup>

would have served as "antiphonal sources" were replaced by clusters of small speakers on the walls above the entrance and exit of the pavilion. The fifty low-frequency loudspeakers that were to be built into the concrete walls behind the lighter partition walls were reduced to 25. And these hidden speakers now provided the only compensation for the lack of low-frequency response from the small speakers on the walls, since none of the ten additional low-frequency four hundred-liter cabinets Tak had initially wanted were installed. Nor was his stand-alone electronic reverberation system with loudspeakers for diffused sound projection. Instead, the reverberation effects necessary for creating the impression of variable acoustics were incorporated into the recording of the music. All these compromises must have hugely disappointed Tak. Nevertheless, the spatialization system is one of the reasons the Philips Pavilion occupies such an important position in the history of electronic music today.

Although the original concept for the system came from Tak and some previous *son et lumière* projects and had been part of the plan for the Philips Pavilion from an early stage, the final design of the sound routes, which determined the positions of the loudspeakers, was

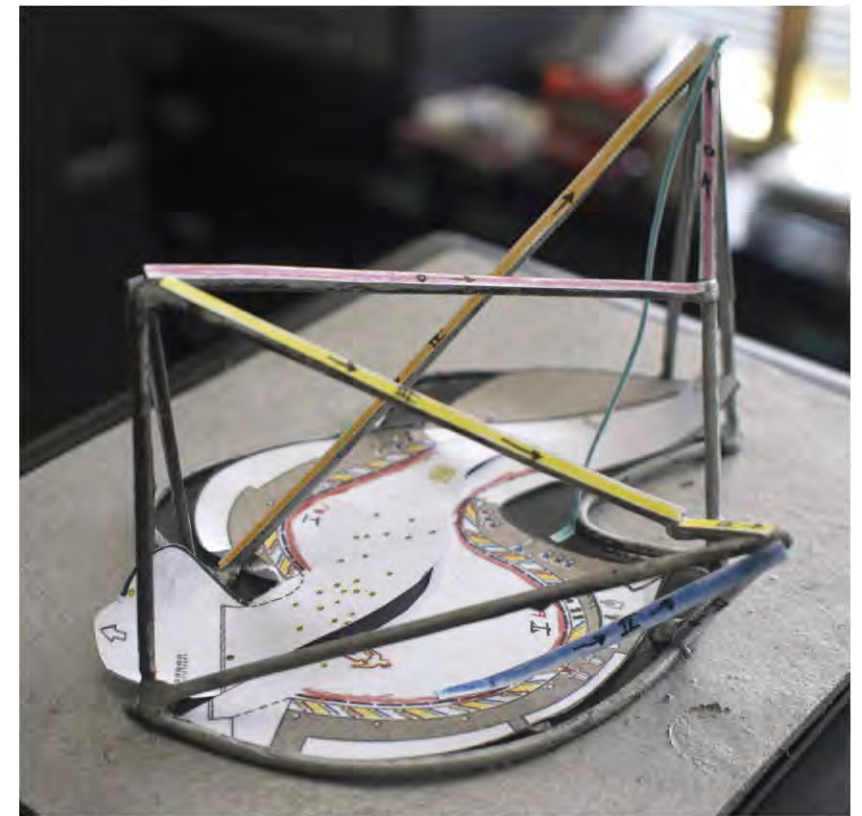

Fig. 2.77: Three-dimensional model made in 2010 by former Philips Pavilion technician Theo Boesveld, which gives a better understanding of Xenakis' drawing in fig. 2.76. Indications of sound routes and floor plan added by author.

created by Xenakis. When Xenakis and Le Corbusier visited the garage in Eindhoven on April 15, 1957, the loudspeaker domes had not yet been rejected. One of the purposes of their visit was to determine the positions of the domes while looking at the exterior of the scale model (see fig. 2.32 and 2.33). The decision to replace the domes with much smaller speaker cabinets mounted directly on the inside walls made the choice of positioning much more flexible. Xenakis was therefore able to base the final sound system's design on the shape of the building itself: the ten sound routes followed its main contours while the clusters A, B and C highlighted its three peaks (13, 18.5 and 20.5 meters high). Loudspeaker clusters J and U (the antiphonal sources) were placed above the entrance and exit.

The first evidence of the presence of loudspeakers on the interior walls of the pavilion is found in a February 7, 1958, photo (fig. 2.78), taken when Le Corbusier, Xenakis and Varèse visited the pavilion while it was being built (see Chapter 5, 139–44). During this visit, Le Corbusier complained about the speakers' even spacing and straight linear formation. He said it reminded him of his grandmother's corset, and he wanted it changed.<sup>200</sup> His complaint was taken seriously, and the final distribution of the speakers on the walls was therefore much more irregular.

The Philips article describing the pavilion's sound system mentions a total of 325 loudspeakers plus 25 low-frequency ones,<sup>201</sup> but other sources give smaller<sup>202</sup> and larger numbers, up to 450.<sup>203</sup> The Philips article does not mention how the speakers were allocated to the various routes and clusters. A more detailed description can therefore be made only by analyzing and comparing existing photographs. A highly valuable source of information is a collection of shots taken by the photographer Hans de Boer and archived at the Nederlands Fotomuseum in Rotterdam. These show the pavilion when construction was nearly finished and most speakers were already mounted on the walls.<sup>204</sup> Along with a photograph by Anton Buczynski<sup>205</sup> and two of the finished interior by the photographer Lucien Hervé, De Boer's photos allow identification of the ten sound routes drawn by Xenakis (fig. 2.76) and the loudspeaker clusters.



*Fig. 2.78: Le Corbusier inspecting the interior of the Philips Pavilion on February 7, 1958. Loudspeakers for the horizontal sound route have been provisionally mounted and covered with plastic to protect them from the impending spraying of the asbestos layer. Their spacing would later be changed at Le Corbusier's request.*



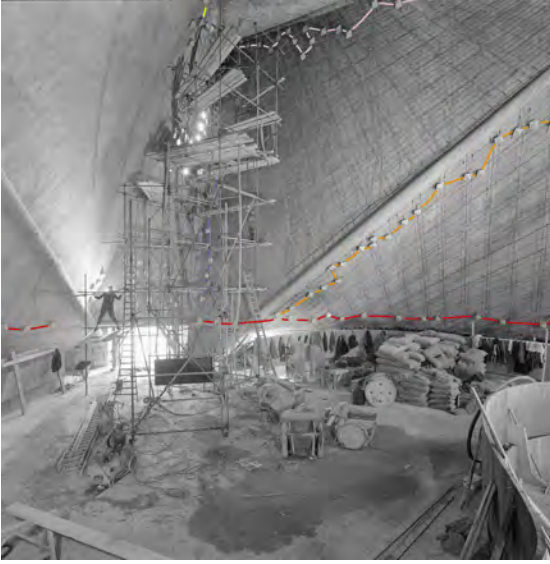

Fig. 2.79: View into peak B, above the pavilion's exit: sound route I (horizontal), marked in red; route III (B→E→A), in yellow (just visible at the top); route IV (U→C), in orange; route O (B→D→C), in pink; and route VII (B→U), in purple (behind the scaffolding). Above the exit is cluster U. Photo by Hans de Boer; colors added by the author, see diagram (fig. 2.76) on foldout on page 154.

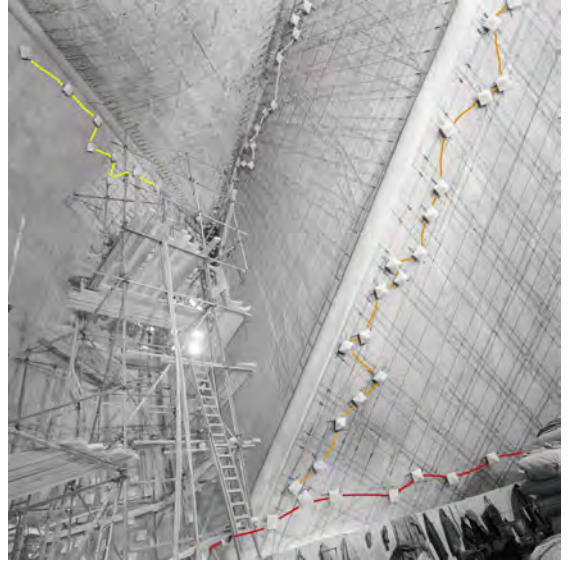

Fig. 2.80: Another view into peak B: sound route I (horizontal), in red; route III (B→E→A), in yellow; route IV (U→C), in orange; and route O (B→D→C), in pink. Cluster U is in the lower left corner. Photo by Hans de Boer; colors added by the author, see diagram (fig. 2.76) on foldout on page 154.

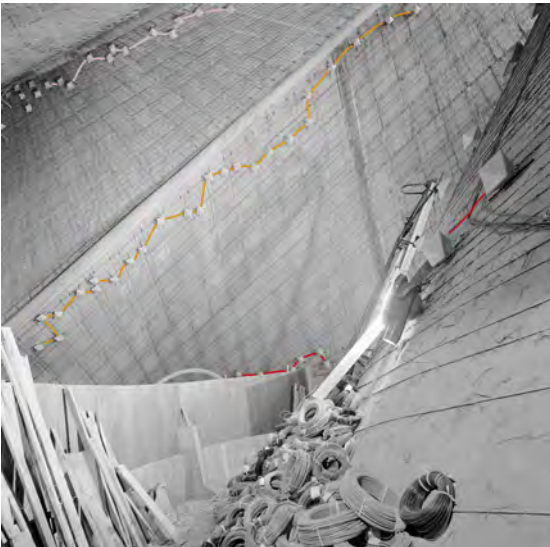

Fig. 2.81: A view further to the right (the cluster in peak B is just visible in the upper left corner): sound route I (horizontal), in red; route IV (U→C), in orange; and route O (B→D→C), in pink. Photo by Hans de Boer; colors added by the author, see diagram (fig. 2.76) on foldout on page 154.

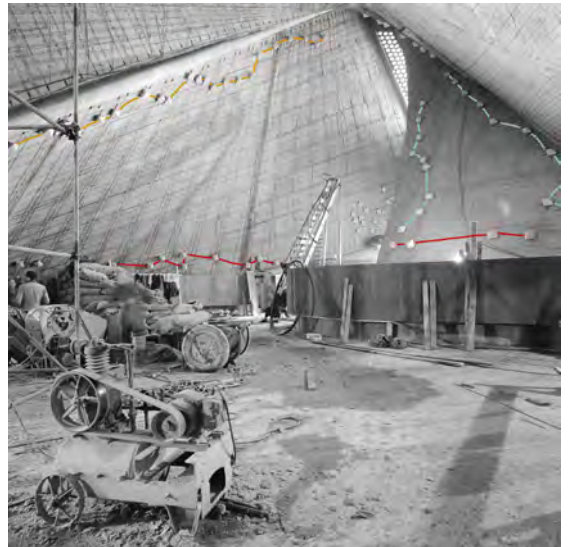

Fig. 2.82: A view toward the pavilion's entrance: sound route I (horizontal), in red; route IV (U→C), in orange; and routes V and VI, in turquoise. Cluster J is visible above the entrance. The loudspeakers for the cluster in peak C and along route VIII (C→J) have not yet been mounted. Photo by Hans de Boer; colors added by the author, see diagram (fig. 2.76) on foldout on page 154.

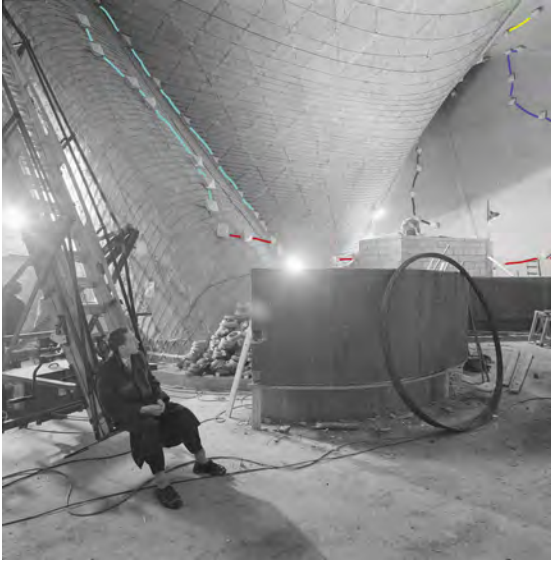

Fig. 2.83: A view toward one of the projection booths: sound route I (horizontal), in red; sound route II (from route I→A), in blue; route III (B→E→A), in yellow; routes V and VI, in turquoise; and route IX (downwards from A), in gray. Route IX starts in peak A, where routes II and III end. The cluster in peak A is just visible. Photo by Hans de Boer; colors added by the author, see diagram (fig. 2.76) on foldout on page 154.

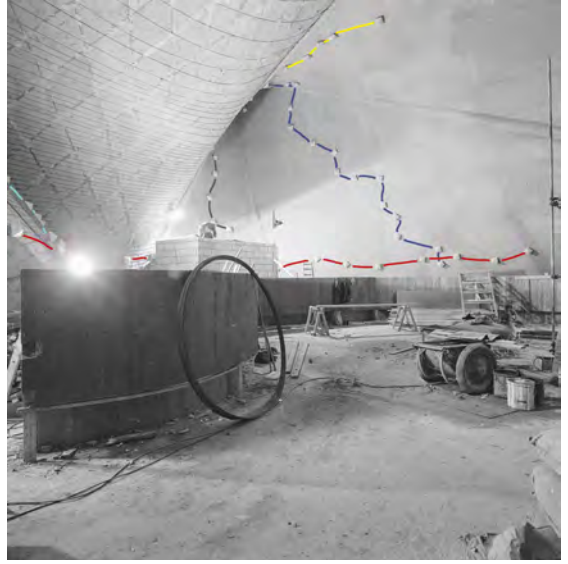

Fig. 2.84: Route V, in turquoise, and route IX (downwards from A), in gray. Route IX starts in peak A, where routes II and III end. The cluster in peak A is just visible. Photo by Hans de Boer; colors added by the author, see diagram (fig. 2.76) on foldout on page 154.



Fig. 2.85: A view in the same direction but further to the right: sound route I (horizontal), in red; sound route II (from route I→A), in blue; route III (B→E→A), in yellow; and route VII (B→U), in purple. Photo by Hans de Boer; colors added by the author, see diagram (fig. 2.76) on foldout on page 154.

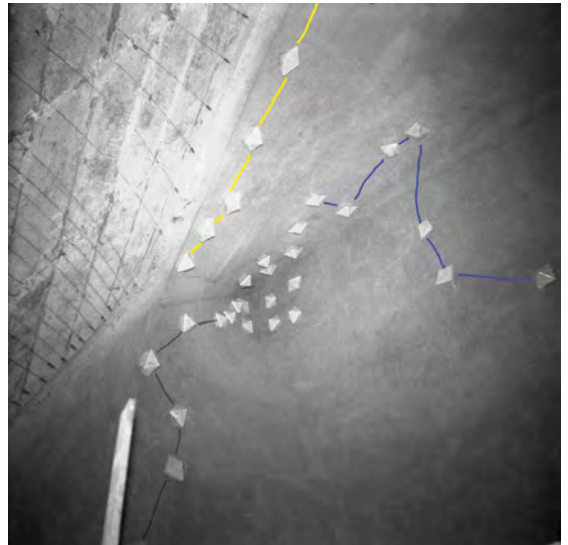

Fig. 2.86: View of the loudspeaker cluster in peak A. Sound route II (from route I→A), in blue; route III (B→E→A), in yellow; and route IX (downwards from A), in gray. Photo by Anton Buczynski; colors added by the author, see diagram (fig. 2.76) on foldout on page 154.

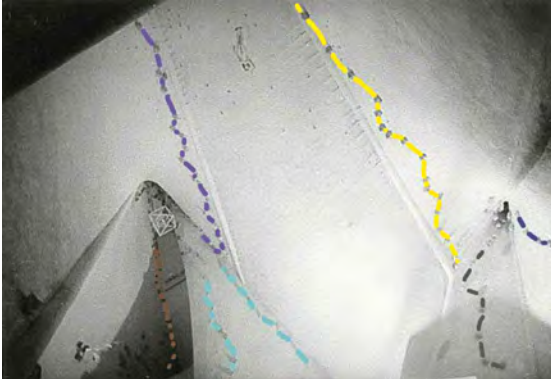

Fig. 2.87: Wide view of the finished interior of the Philips Pavilion, with loudspeaker clusters in peaks C (left) and A; sound route II (from route I→A), in blue; route III (B→E→A), in yellow; route O (B→D→C), in pink; route VIII (C→J), in brown; and route IX (downwards from A), in gray. Also visible are the two volumes that played a role in Le Corbusier's scenario: the mathematical object (in peak C) and the female figure (seen upside-down between the pink and yellow routes). (Peter Wever pointed out that this figure differed from the one that appeared in later photos.) Photo by Lucien Hervé; colors added by the author, see diagram (fig. 2.76) on foldout on page 154.

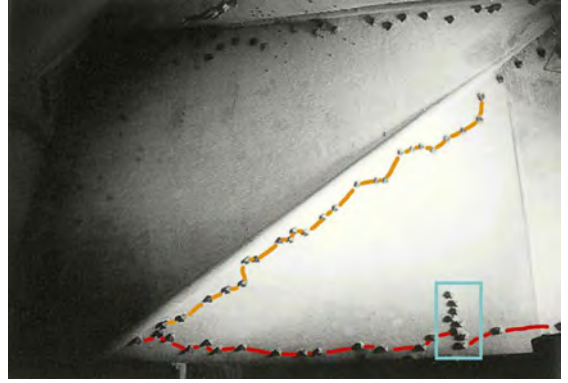

Fig. 2.88: Another view of the finished interior, with sound route I (horizontal), in red, and route IV (U→C), in orange. An unidentified additional cluster of loudspeakers (compare with fig. 2.81) is marked by the blue rectangle. Photo by Lucien Hervé, colors added by author, see diagram (fig. 2.76) on foldout on page 154.

Examination of these photos also enables a fairly reliable count of the total number of loudspeakers. The figure of 325 mentioned in *Philips Technical Review* appears to be correct.<sup>206</sup>

The installation in the control room of the Philips Pavilion consisted of a three-channel perfo tape machine for playing the music and a fifteen-channel perfo tape machine for playing the control signals for the automated performance. Each channel on the fifteen-channel tape could contain up to twelve simultaneous control signals, bringing the total number of control signals to 180. These signals had specific frequencies, the lowest being 900 Hz and the highest 10,500 Hz.<sup>207</sup> Each control channel output was connected to twelve parallel narrow bandpass filters, which were tuned so that each matched one of the frequencies on a control channel. When a control signal matched the bandpass frequency of a filter, that filter would output a signal, which, after amplification, could activate another device. The combination of a bandpass filter and an amplifier was called a selective amplifier. The activated device might be a relay that turned on a group of loudspeakers or a rotary switch that set a sound route in motion, but the visuals for *Le poème électronique* were also controlled in this manner.<sup>208</sup>

While most control signals were continuous, the rotary switches for the sound routes were controlled by short impulses with a maximum repeating frequency of ten per second. According to the article in *Philips Technical Review*, there were five rotary switches for the sound routes with 52 steps each. This means a maximum of 260 loudspeakers was available for a



total of ten sound routes.<sup>209</sup> Assuming there were 325 loudspeakers in total, 65 loudspeakers were used for the clusters. Based on the photographic evidence, this is a realistic figure.

The three-channel perfo tape containing the music and the fifteen-channel perfo tape containing the control signals were played in sync through the use of an “electrical shaft.”<sup>210</sup> The four film projectors for the visual layers of *Le poème électronique* were synchronized with the music and control signals via the electrical shaft as well. Although the article in *Philips Technical Review* briefly mentions this technique, it is not described in detail. In 1983–1984, after Tak made negative statements about *Le poème électronique* in several interviews, serious doubt was raised about whether the equipment necessary for this synchronization had functioned properly or even been installed at all.<sup>211</sup>

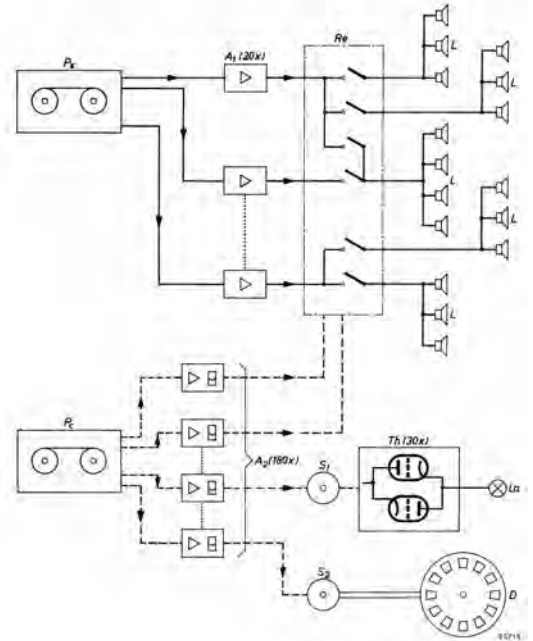

Fig. 2.89: Simplified diagram of the installation in the Philips Pavilion: three-channel tape with music ( $P_m$ ), fifteen-channel control tape ( $P_c$ ), amplifiers feeding the loudspeakers ( $A_1$ ), selective amplifiers ( $A_2$ ), relays ( $Re$ ), and loudspeakers ( $L$ ).  $S$ ,  $Th$ ,  $La$  and  $D$  refer to visual elements of “*Le poème électronique*.”

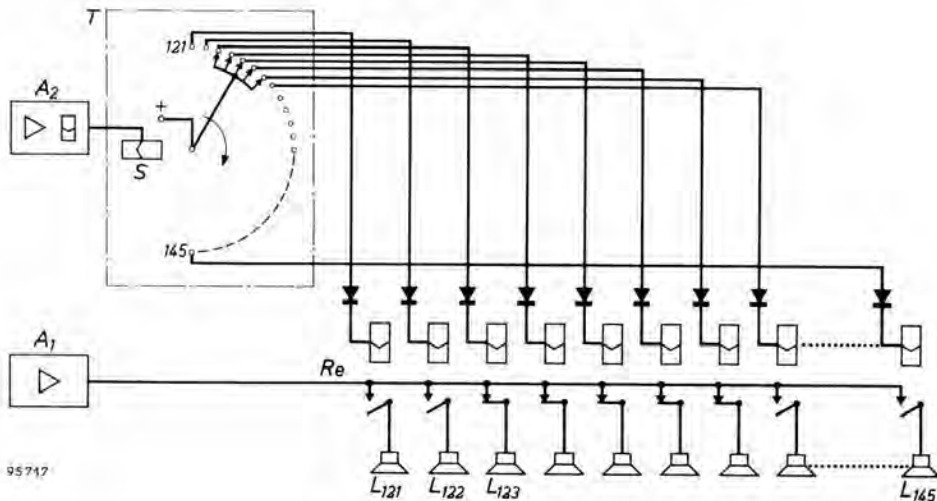

Fig. 2.90: Diagram of a sound route: the amplifier ( $A_1$ ) that outputs the audio to the loudspeakers and a selective amplifier ( $A_2$ ) that outputs the impulses on the control channel as electrical signals that activate the coil ( $S$ ) of the rotary switch ( $T$ ). Each output from the rotary switch is connected to a relay that operates one of the route’s loudspeakers. The rotary switch connects five speakers to the output of an amplifier. With each step of the switch, one loudspeaker is turned off as another one is added.



Fig. 2.91: Perfo tape machines in the control room of the Philips Pavilion: the two three-channel units for the music at left and one of the two fifteen-channel units for the control signals at right (the second is not visible in the photo). During performances, only one three-channel and one fifteen-channel machine were used at a time.



Fig. 2.92: Philips installation for the simultaneous recording of fifteen channels, used, for instance, at air fields to record conversations between air traffic control and planes.

However, according to Paul Vancoppenolle (\*1931),<sup>212</sup> one of the Belgian “projecteurs” (film operators) at the Philips Pavilion, the synchronization or “interlock” equipment worked flawlessly from the first day the public was allowed to witness *Le poème électronique*. Only twice in the estimated 3,000 shows that took place between May 20 and October 19, 1958, did the interlock system fail and the operator in the control room have to give a command “à la main” (by hand) instead. Not only did Vancoppenolle give a detailed description of the daily routine for performing *Le poème électronique*, he made an 8mm color film of the technical procedures in the pavilion, which fully supports his description. As Vancoppenolle explained, the films of the visuals were moved up to marked points using the transports of the individual projectors, in a similar manner to the tapes of the music and control signals. The projectors were then stopped and switched over to respond to the interlock machine’s control signal. The signal made the projectors’ motors hum loudly, and when the whole system was then activated through the pushing of a single button on the central control desk, all machines immediately started and ran at the correct speed, staying synchronized.<sup>213</sup>

Screenshots from Paul Vancoppenolle's 8 mm film:



Fig. 2.93, 2.94 and 2.95: Wiel Cox at the central control desk (left); the button on the control desk that turned on the entire show (middle); the interlock system.



Fig. 2.96, 2.97 and 2.98: The perfo tape machine with the fifteen-channel control tape (left); transporting a film on one of the projectors to the marked point (middle); the film ready to be started by the interlock system.

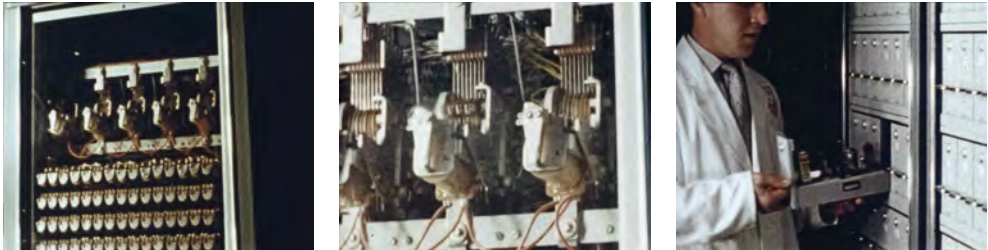

Fig. 2.99, 2.100 and 2.101: Cabinet containing relays and rotary switches for controlling the loudspeakers (left); a close-up of the rotary switches (middle); technician removing one of the selective amplifiers.



Fig. 2.102, 2.103 and 2.104: A close-up of a relay of a selective amplifier (left); colored fluorescent lights for the "ambiances."



Fig. 2.105: Demonstration for the Philips board of directors and their wives, April 18, 1958.

## Edgard Varèse in Brussels

After Varèse left for Brussels on April 8, 1958, Buczynski stayed in Eindhoven, where he continued to work on the panoramic effects and the final mixing of the individual tapes to the perfo master tape.<sup>214</sup> From Kalff's April 9, 1958, letter to Xenakis, it appears that Tak, too, was still working in Eindhoven "day and night to get Varèse's composition ready for the pavilion with all the three-dimensional effects."<sup>215</sup> Presumably, his work included preparation of the fifteen-channel control tape.

Three days after his arrival in Brussels, Varèse attended a test in the pavilion with Le Corbusier, where he found only sixty loudspeakers working at the proper levels.<sup>216</sup> Yet a first rehearsal of a large part of the music and images, in the presence of Le Corbusier, Varèse, Kalff, De Bruin and Tak, was planned for the afternoon of Sunday, April 13.<sup>217</sup> Time was running out: the World's Fair would open on April 17. And on top of the problems with the sound installation, Le Corbusier had suddenly withdrawn his scenario after the test on the 13th.<sup>218</sup> Changing the scenario meant changing the signals on the control tape, obviously a complicated matter.

Varèse showed his concern at the need for improvements to the sound system and stayed at the pavilion practically every day.<sup>219</sup> A press demonstration was given on April 17, the opening day of the World's Fair, but the sound was still bad,<sup>220</sup> and it would not be until May 20 that *Le poème électronique* could finally be witnessed by fairgoers.<sup>221</sup> Nevertheless, more demonstrations and formalities took place at the pavilion in the first days of the fair.<sup>222</sup> Although Kalff explicitly requested Le Corbusier's presence on these occasions,<sup>223</sup> he did not appear at any of them.



In spite of all these festivities, the pavilion's installation was still not functioning properly, and the visual layers of the performance were not ready either. Technical work was constantly being done in both Eindhoven and Brussels. On April 23, 1958, Kalff made arrangements with De Bruin (responsible for the automation) and Tak in the hope that it would be possible to do thirteen complete test runs in succession on May 1 and then open the pavilion to the public on the 2nd.<sup>224</sup> Apparently, Varèse was now satisfied with the way his music was being reproduced in the pavilion. In a letter to Xenakis, he wrote



Fig. 2.106: Louis Kalff (second from left) and Edgard Varèse (right) at a lunch at the Canadian pavilion after the demonstration at the Philips Pavilion for Philips' Belgian management, April 22, 1958.



Fig. 2.107: A World's Fair audience waiting to enter the Philips Pavilion on May 20, 1958, the first day of regular performances of "Le poème électronique." The text at the entrance says: "Philips - Poème électronique - Séances de 8 minutes pour 500 personnes - Création du Poème et architecture Le Corbusier - Composition et son Edgar Varèse - Animation et effets de lumière ir Louis Kalff - Architecture et Interlude sonore Y. Xenakis - Effets acoustiques ir. W. Tak - Projections Ph. Agostini - Images J. Petit - Automation S. L. de Bruin."



Fig. 2.108: Three-channel 35 mm perforated audiotape dated May 11, 1958, with the final master of the music for the Philips Pavilion; Institute of Sonology archive. Photo by author.

of “[y]our piece which comes over as sound and spreads admirably – and mine, which comes over well too. Everything will be ready next week, and I think we shall have all the sound and fury required.”<sup>225</sup> On May 20, 1958, *Le poème électronique* was finally witnessed by the general public for the first time.<sup>226</sup>

Varèse, however, wanted things changed further. He had an appointment with De Bruin on May 25. In spite of the fact that, according to the composer, “Goddamn Tak [was] always wanting to inject his stinking ego,” Varèse thought it was possible to make more improvements.<sup>227</sup> He had another meeting with De Bruin several days later to go over the tape again. Varèse insisted that a “connection in the music” had to be made at all costs.<sup>228</sup> As editing the music itself was not possible in Brussels (the timing of the sounds and synchronization of the three channels were fixed on the perfo tape), the improvements he had been concerned with since arriving in Brussels must have been related to its spatial distribution. Varèse had familiarized himself with the spatial possibilities of the system in the pavilion before starting work on the music (see Chapter 5, 127–39) and was also passionately involved in the spatial reproduction of his final composition in the pavilion. This is another reason to doubt Tak’s aforementioned claim that Varèse had mostly left decisions regarding sound spatialization to the Philips technicians.<sup>229</sup>

Varèse stayed in Brussels until June 18, 1958, when he and his wife traveled to Paris.<sup>230</sup> From there, they returned to New York in July.<sup>231</sup>

## Presenting *Le poème électronique* to the Public

Le Corbusier had not fulfilled Kalff’s explicit request for his presence at the official events at the pavilion on April 18, 22 and 23, 1958, but he visited it on June 26 and signed the guest book on that occasion. Varèse never signed the guest book at all.

Le Corbusier later complained to Kalff that he had never received a friendly word from Philips’ directors for the enormous effort he had expended on the pavilion: “This is called, purely and simply, human ingratitude.”<sup>232</sup> Kalff replied that Le Corbusier’s scenario had met with some bad reactions among the board members and that the presentation had been incomplete at the time of the pavilion’s opening. Enthusiasm on their part had therefore been impossible. And even now, on July 28, 1958, *Le poème électronique* was still in the course of being perfected. But Kalff added that public opinion had changed considerably. Above all, “the





Fig. 2.109 and 2.110: Guest book for the Philips Pavilion; Le Corbusier's signature dated June 26, 1958, with a word of thanks extended to "Philips" (sic). Photos by author.

esteem shown by architects, musicians and artists" had convinced Philips' administration that *Le poème électronique* had been "worth the effort and considerable funding invested in it."<sup>233</sup>

As the public entered the pavilion, they saw, through the windows of the control room to the right, the complex equipment required for the automatic running of the performance. Once they got inside, they heard Xenakis' *Interlude sonore*. Meanwhile, an introductory text rolled across the curved walls in three languages. Then the eight-minute *Le poème électronique* began with the deep tolling of a bell. The light projections enveloped the pavilion's interior in an intense, uniform flood of color or split it into horizontal or vertical bands of color. Through these hues, large black-and-white film images were projected on opposite sides. At appointed times, there appeared colored clouds, a white moon, a flash of lightning, a red sun and a starry sky. Also appearing on opposite sides at certain moments were the so-called *tri-trous*: three small projection areas around each of the large film images, sometimes containing images themselves and sometimes only colors. Hanging from the ceiling were the "volumes": a mathematical object and a female figure. These were covered in phosphorescent paint and were visible only when ultraviolet light was shone on them. The lighting and the projectors were hidden, so the audience saw only the projected images, lights and colors. After the performance ended, with tremendous explosions of sound and the projected faces of babies, the overwhelmed audience left the pavilion. An estimated one to two million visitors saw *Le poème électronique*.<sup>234</sup>

With the music for the Philips Pavilion, Le Corbusier's wishes were finally fulfilled. He had made two earlier attempts to involve Varèse in his projects: a film about his *Unité d'Habitation* building in Marseilles in 1951 and an electronic carillon for the campanile at the Notre Dame du Haut chapel in Ronchamp in 1954. For the latter, Le Corbusier had imagined "beautiful fragments of ancient liturgical music set against a background of modern music, disrupted

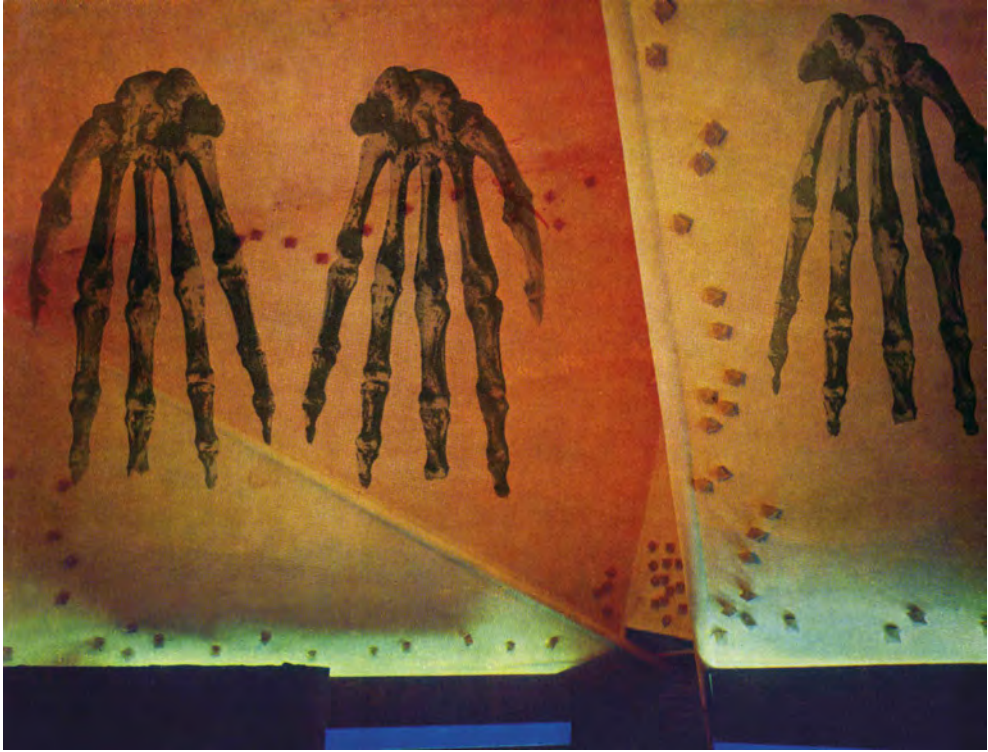

Fig. 2.111: Interior of the Philips Pavilion with simulated projections of “*Le poème électronique*.”

by violent or impersonal bursts [...] of modern music.”<sup>235</sup> Although *Le poème électronique* is not a religious work in the true sense, it certainly has religious aspects. The first chapter is called “Genese” (Genesis); in the second chapter, images of Jesus Christ and the Virgin Mary appear as consolation for the cruelty of concentration camps. The fourth chapter, “Des dieux faits d’hommes” (Man-made gods), shows statues on Easter Island and images of Buddha. In the seventh and last chapter, there is a 1½-minute sequence filled with stills of Le Corbusier’s architecture, which looks as if it has been taken from a documentary.<sup>236</sup>

In the end, it is difficult to establish the extent to which Le Corbusier’s scenario was used as a guideline for the music. Le Corbusier and Varèse often emphasized the mutual independence of the music and visuals, and their desire to avoid a cartoonlike effect, in which the music would illustrate the images or vice versa, attests to great understanding of the effective use of simultaneous visual and sonic layers. On the other hand, the music, with its tolling bells, vocal parts and organ sounds, goes extremely well with Le Corbusier’s visual narrative, and there appears to be a similarity between the kind of music he had previously requested for Ronchamp and the sounds in *Le poème*.<sup>237</sup>

In 1960, Columbia Records released a phonograph record of music by Varèse, which included *Le poème électronique*.<sup>238</sup> The same album was released as part of Philips’ Modern

Music Series. The liner notes mention *Le poème électronique* as an example of organized sound (the same term Varèse had used for the interpolations in *Déserts*). Varèse rejected the term *musique concrète* to describe his music, partly because, as he wrote later to Fernand Ouellette, he didn't "wish to be associated with '*musique concrète*,' or with any other clique."<sup>239</sup> The liner notes go on to say:

No synchronization between sight and sound was attempted by the two artists [Varèse and Le Corbusier]; part of the effect achieved was the result of a discordance between aural and visual impressions and part the result of their not infrequent accidental concordance. [...] Varèse is reticent about the emotional content of his *Poème*, insisting that it must speak for itself. But perhaps a remark he made about the female voice heard toward the end of the composition may provide a key: "I wanted it to express tragedy – and inquisition."<sup>240</sup>

October 19, 1958, was the last day of the World's Fair and the last day *Le poème électronique* was performed in the Philips Pavilion. Dismantling of the sound installation began the next day.<sup>241</sup> A first attempt to demolish the building was made on January 30, 1959, but failed. It was destroyed on February 2 with the aid of explosives.<sup>242</sup>



Fig. 2.112: Partially demolished Philips Pavilion, January 30, 1959.

**Part III**

**Electronic**

**Music**

**Pervades**

**Public Culture:**

**Organizations,**

**Studios,**

**Concerts,**

**Education**

## Chapter 7

# The First Steps towards a Dutch Electronic Music Studio

### Walter Maas and the Founding of Gaudeamus

Most of the artistic output produced at Philips described in the previous chapters was related to the development of certain technologies: participation by composers and musicians had been sought at moments when technological developments were ready to be tested or demonstrated. An initiative with its roots in the opposite – the need for technology from the perspective of composers and musicians – came from Walter Maas (1909–1992). Maas had grown up in Mainz, Germany, where his father had been a wealthy wine trader. Music had been of great importance in the family home. Whenever a famous musician performed in Mainz, he was hired to give a private concert at the Maas residence.<sup>1</sup> Walter Maas came to the Netherlands in 1933, after a Nazi decree made it impossible for him to perform his work as a textile engineer in Germany. In the course of the 1930s, his parents and other members of his family joined him in The Hague. During the first months of the German occupation of the Netherlands, the Jewish Maas family was forced to leave the city. They moved to a house known as Huize Gaudeamus in Bilthoven, a small town near Utrecht. Maas' parents turned it into a boardinghouse. Maas went into hiding in 1942, but his parents were deported to the Nazis' Westerbork transit camp in 1943. After the war, Maas returned, bought Huize Gaudeamus, and continued to run the boardinghouse started by his parents, who had not survived the war.

To show his gratitude to the people of the Netherlands, Maas decided to turn the house into a music center.<sup>2</sup> He immediately began organizing events to promote contemporary music in the Netherlands, leading to the establishment of the Gaudeamus foundation in 1950 and the annual Gaudeamus Muziekweek from 1951 onwards. He was familiar with the concept of house concerts from his youth in Mainz and got the idea of supporting the new generation of composers from the pianist and composer Henk Stam (1922–2002), a coorganizer of the Gaudeamus concerts from the beginning. Today, in general, the important changes in compositional approaches that took place in the Netherlands after 1945 are associated with Gaudeamus.<sup>3</sup>

Maas frequently traveled around Europe, visiting music festivals, and he had become conscious of the development of a broad contemporary music movement. The International Summer Course for New Music in Darmstadt, Germany, started in 1946, but Maas would say with a certain pride, "Darmstadt was early, but I was earlier!"<sup>4</sup> For Maas, electronic music was primarily a new form of composition that he had come across in Germany. Through Ton de

Leeuw, who lived in Huize Gadeaumus' garden house from 1951 to 1952, he learned about the *musique concrète* of Paris, where De Leeuw had studied with Olivier Messiaen (see Chapter 3, 86–7).

## Werner Meyer-Eppler's Lectures

Werner Meyer-Eppler gave his first lecture in the Netherlands, entitled “Welche Möglichkeiten bestehen für eine sinnvolle Anwendung elektronischer Musikinstrumente?” (Which possibilities exist for a sensible application of electronic musical instruments?), on June 18, 1953, at the first International Acoustics Congress in Delft, the same gathering where Roelof Vermeulen gave the first official presentation of the Philips electronic reverberation system (see Chapter 2, 53–9). In September 1953, Maas led a Dutch delegation to the 2. *Internationale Kunstwoche der Musikalischen Jugend Deutschlands* (Second international arts week for musical German youth) in Munich. There, on the 9th, he heard Meyer-Eppler's lecture “Elektronische Musik,” and he decided to invite him to give a similar talk in the Netherlands. When Maas and Stam traveled to Cologne in January 1954, they took the opportunity to have a personal meeting with Meyer-Eppler in Bonn.<sup>5</sup> Through Maas' efforts, Meyer-Eppler's influence in the Netherlands in the following years was considerable.

With Robert Beyer, Meyer-Eppler had presented the first results from his models for synthetic sound production at the International Summer Course for New Music in August 1951. They had made the sounds on a Melochord – an electronic instrument developed by Harald Bode – and an AEG magnetic tape recorder. Meyer-Eppler's experiments were broadcast by Herbert Eimert on October 18, 1951, on a Nordwestdeutscher Rundfunk (NWDR) nighttime radio program, and NWDR made its decision to establish a studio for electronic music on the same day. However, the first electronic pieces made at NWDR were produced in one of the *Tonträger-Räume* (recording rooms), which had the usual measuring equipment and two tape recorders. It would not be until early 1953 that Meyer-Eppler and Fritz Enkel (1908–1959), the chief of testing and measurement techniques, built the actual electronic music studio. Stockhausen first visited that studio in May that year.<sup>6</sup>

At the time Maas made his invitation to Meyer-Eppler, the Cologne studio was still very young. Only nine pieces had been composed so far (including *Studie I* by Stockhausen), and most of them were only a few minutes long.<sup>7</sup> In the Netherlands, no studio for electronic music existed yet, and only one piece including electronic sounds had been composed: Henk Badings' music for the radio play *The Countess Cathleen* (see Chapter 3, 64–6).

Maas' invitation resulted in “Elektronische Musik,” a lecture Meyer-Eppler gave to an audience of young composers and musicians in Bilthoven on May 16, 1954. Maas also invited Vermeulen and representatives of broadcasting companies to the lecture, and Philips was asked to supply the equipment needed for playing the audio examples.<sup>8</sup> Vermeulen accepted



the invitation, and although Philips normally would not honor such requests, it made an exception for this occasion. In his lecture, Meyer-Eppler explained that using an instrument whose sound range was extended through the presence of electronic elements did not make a piece of music electronic. Such instruments were mainly useful in the production of popular music and were created out of economic considerations, as replacements for members of the orchestra. According to Meyer-Eppler, electronic music wasn't about sounds that came into being through the playing of an instrument or compositions that needed interpretation: electronic music was music that was transferred by the composer personally and immediately onto magnetic tape. "The electronic music composer no longer needs a medium to realize his art," a newspaper commented. "That art now goes directly from him to the listener."<sup>9</sup>

Though Vermeulen found Meyer-Eppler's lecture and demonstrations interesting, he was unable to formulate a practical objective out of them.<sup>10</sup> Vermeulen's own research certainly did not exclude "normal" musical instruments based on electronics or modified electronically. He had been involved in the development of such instruments at least since 1945 and would install several in the electronic music studio at Philips Research Laboratories in 1956. These instruments would be used to produce both the art music of Henk Badings and the popular electronic music of Kid Baltan and Tom Dissevelt.

Maas made his first attempt to establish a Dutch studio for electronic music at the Nederlandse Radio Unie (NRU) broadcasting company. Such studios had already been opened at radio stations in Germany and France. Shortly after Meyer-Eppler's lecture in Bilthoven, Maas visited Hilversum, where he discussed the possibilities for a studio with the acting director of the NRU's music department, H. Passchier. Subsequently, Passchier asked Meyer-Eppler what kind of equipment would be necessary.<sup>11</sup> Meyer-Eppler suggested starting with three tape recorders, a mixing desk, an electronic instrument such as a Melochord, a noise generator, a ring modulator, a reverberation room or electronic reverberation device, and various filters.<sup>12</sup> In the end, the NRU did not establish a permanent electronic music studio. However, on November 22, 1954, an improvised setup was created there for electronic music experiments by a small group of composers, musicians and technicians, supervised by Meyer-Eppler.<sup>13</sup> That session was followed by another Meyer-Eppler lecture the next evening at the NCRV studio.<sup>14</sup>

## **Electronic Music at the Nederlandse Radio Unie**

Henk Badings finished his 54-minute radiophonic opera *Orestes* in July 1954.<sup>15</sup> At that time, he was the only well-known composer in the Netherlands to have used electronics in music.<sup>16</sup> After *Orestes* won the Prix Italia, it certainly became easier to explain the importance of making a permanent electronic studio available to composers. Thanks to the prize, the work was broadcast by more than nine hundred radio stations worldwide. But another effect of the prize was that Badings became a leading figure in electronic music in the Netherlands whom the

Gaudeamus composers could not ignore, in spite of his conservative approach to composition and their growing interest in the European avant-garde. At the 1954 Gaudeamus Muziekweek, held from August 28 to September 4 in Bilthoven, Badings was invited to give a course on technical problems faced by contemporary composers; he discussed subjects such as the development of rhythm, tonal systems, existing and future tuning possibilities, the twelve-tone technique, and electronic music.<sup>17</sup>

In spite of the success of *Orestes*, the NRU appeared unwilling to permanently install a studio where young composers could explore the musical potential of electronics. Maas therefore tried to convince Vermeulen and Philips Research to do so instead. But Philips did not see what kind of help it might be able to offer, and it questioned whether adding a new subject to its already overloaded research program would be wise. Nevertheless, the company was willing to discuss the matter further with Stam and Badings.<sup>18</sup> Maas, Stam and Badings visited Vermeulen at Philips in Eindhoven on December 13, 1954, but this first meeting did not lead to immediate results. Nevertheless, Maas expressed the hope that

one way or another, the new electronic materials will be made available to the many musically creative talents that we have in this country. While, as has already been said, [Heinrich] Heine averred that on Judgment Day he would want to be in the Netherlands, since everything there is thirty years behind the times, our motivation is to do everything possible to correct this delay [...]. In this area [electronics], Philips itself is a world leader, and it is therefore in an outstanding position to assist us in the aforementioned efforts.

Our next international music week will take place from August 29 to September 3, 1955, and since this is a jubilee year for us, it would be extraordinarily fulfilling for us if a way to realize our plans could somehow or other be found.<sup>19</sup>



Fig. 3.1: Piet Bottema, Ton de Leeuw and Arie Brandon during production of *Job* in one of the NRU's studios, 1956.

Maas was obviously not inclined to give up. But by May 1955, it was clear that there would be no collaboration with Philips at 1955's Muziekweek.<sup>20</sup> Instead, the November 1954 event at the NRU was more or less repeated, this time under the supervision of Badings instead of Meyer-Eppler. On August 12 and 13, Badings, Hans Kox, Peter Schat and Elbert Vermaak (\*1929) conducted experiments with a temporary, improvised equipment setup; the results were presented to the public on September 2 during Muziekweek.<sup>21</sup>

Maas again visited Eindhoven on November 5, 1955. There, Vermeulen demonstrated the optical siren and the multivibrator to him (see chapters 1, 33–5 and 2, 62–4). Maas reported on the experience to Badings, who expressed a desire to use both devices in the future.<sup>22</sup> Maas was still hoping the NRU might decide to install a permanent electronic music studio, but on November 30 he received a letter definitively stating that it would not do so for now.<sup>23</sup> The following year, the NRU commissioned Ton de Leeuw to compose the radio oratorio *Job* for soloists, mixed choir, orchestra and electronic sounds, but again, the equipment for the production of those sounds was only temporarily installed in one of its radio studios. Like Badings, De Leeuw won the Prix Italia. De Leeuw now enjoyed similar esteem, but artistically he represented an entirely different way of thinking (see Chapter 3, 86–7).

## **Chapter 8**

### **An Organization for the Promotion of Electronic Music**

#### **The Contactorgaan Elektronische Muziek**

Vermeulen and Philips had not gone along with Maas' suggestion in December 1954, but in April 1956, a studio was installed in Room 306 of Philips Research Laboratories, around the time of production of De Leeuw's *Job*. This new studio was certainly the most advanced in the Netherlands so far, but it did not fulfill the needs of Maas and the composers connected to Gaudeamus. Philips had offered Badings the opportunity to produce the electronic ballet music *Kain en Abel*, and the studio was temporary and set up specifically and solely for this purpose. There were no indications yet that it would ultimately exist until the end of 1960. The studio in Room 306 was dismantled after the production of *Kain en Abel*, and it was not until October 1957 that it was rebuilt and another piece was produced there: the pop tune "Song of the Second Moon" by Kid Baltan.<sup>24</sup> Within the scientific context of Philips Research, the studio in the acoustics department never would have been able to serve Maas' main objectives of providing education and creating an environment where many composers could experiment and produce commissioned works. Maas therefore had to continue his search. On May 2, 1956, he visited the Technische Hogeschool Delft (TH Delft) and had a meeting with Cornelis Willem Kosten (1913–1976) and Willem Kok (1910–2002) of the acoustics research group. They concluded that the college probably offered the best climate for establishing a studio that would fulfill the needs of composers.

Maas was apparently very determined to establish a studio for electronic music. To support this goal, he came up with the idea of founding an organization in which numerous electronic music-related parties in the Netherlands would be represented. The possibility of holding a

meeting to discuss starting an electronic studio had been on the agenda of the Gaudeamus annual assembly of June 9, 1956. Badings, however, said he would not come to such a meeting if De Leeuw was going to be there, since, according to Badings, De Leeuw had insulted him. Tension between Maas and Badings had also grown after Maas had been refused attendance at a meeting at Badings' house of the "study center for experimental music"; Wouter Paap had offered to act as a mediator in that conflict.<sup>25</sup>

Maas called an exploratory meeting regarding the building of an electronic music studio on July 9, 1956. Those he invited included the NRU's Eli Bomli (1897–1970) and P. A. I. Huydts; TH Delft's Kok; De Leeuw and Stam of Gaudeamus; Vermeulen from Philips; and Hendrik Eduard Reeser (1908–2002) of the Maatschappij tot Bevordering der Toonkunst (Society for the promotion of music) – but not Badings. The meeting concluded with the decision to establish the "Contactorgaan" (Contact organization), which would function as a platform for the further discussion of the building of an electronic music studio.<sup>26</sup> However, before this organization was officially founded, the 1956 edition of Gaudeamus Muziekweek took place from August 25 to September 1.

No serial music had yet been composed in the Netherlands, and dodecaphonic works were mostly being received with considerable skepticism in the press. Although Paap had offered to act as a mediator in an attempt to ease tensions between Maas and De Leeuw on the one hand and Badings on the other, his review in the periodical *Mens en Melodie* of a concert during Muziekweek added fuel to the fire. Whereas according to Paap, the composers at Gaudeamus had managed so far to bypass "Zwölfönerei"<sup>27</sup> remarkably safely, the 21-year-old composers Peter Schat (1935–2003), Jan van Vlijmen (1935–2004) and Otto Ketting (1935–2012) had turned out to be disciples of the series. As Paap wrote, it was difficult for him, being the anti-atonalist he was, to form an opinion on the "truly creative talent of music students who wander about in the dusky domains of Schoenbergianism. They drill into the sound, but they do not arrive at the music."<sup>28</sup> One only needs to look at the words Badings used to express his aversion to dodecaphonic music in 1936 ("the stains of twelve-tone techniques")<sup>29</sup> to understand whose side Paap was on.

In another article in the same issue of *Mens en Melodie*, Paap wrote that with *Kain en Abel*, Badings had distinguished himself from the electronic revolutionaries on an essential point: he had maintained a clear connection with traditional musical language.<sup>30</sup> According to Paap, Badings might even have applied "typically non-musical electronic sounds" at exactly those points in the score where the destructive elements in the Cain and Abel tragedy were in play (such as in the murder dance) in order to criticize the "electronic extravagances" of the Cologne school's revolutionaries.<sup>31</sup> Paap ended his review of Muziekweek by briefly remarking that demonstrations had been given in the areas of concrete and electronic music by the best experts invited from abroad.<sup>32</sup>

Maas had indeed invited some of the best experts from abroad, but Paap apparently saw no need to mention their names. The people involved in the upcoming founding of the Contactorgaan were all invited to their lectures and concerts, in which the Cologne school was

strongly represented. Meyer-Eppler lectured on the scientific foundations of electronic music.<sup>33</sup> Stockhausen gave a lecture about electronic music in Germany and also performed his *Gesang der Jünglinge*, which he had completed earlier that year. In his lecture, Stockhausen warned composers as well as commissioners and listeners not to consider electronic music as something sensational. Only those composers who, through Anton Webern (1883–1945), had arrived at a point where traditional musical instruments were no longer sufficient for realizing their ideas could make proper use of the new medium, he said. Stockhausen also explained how a spherical concert hall would be ideal for listening to electronic music in the future. Listeners would sit in the middle of the sphere on a platform, where they would be able to truly experience the music, which would come from loudspeakers placed all around them.<sup>34</sup> For the concert of *Gesang der Jünglinge*, performed in Bilthoven with Gottfried Michael Koenig's *Klangfiguren II* (1955–1956) and Herbert Eimert's *Fünf Stücke* (1955–1956), Philips brought in four amplifiers and twelve loudspeakers, so the music would come from all directions.<sup>35</sup>

But the Cologne school's opposite current, the French *musique concrète*, was represented in Bilthoven as well. Maas had invited Pierre Schaeffer to give a lecture, though it was delivered instead by his delegate, the composer and film director Philippe Arthuys (1928–2010). Maas apparently not only wanted electronic music to be created by Dutch composers and performed in concert; he also wanted to provide these composers with theoretical input. Maas saw electronic music education as both a technical affair and a matter of music theory. And he presumably wanted to neutralize Badings' conservative influence somewhat by inviting these important pioneers of the German and French avant-garde to the Netherlands.

Soon after the 1956 Muziekweek, the first official assembly of the "Contactorgaan tot oprichting van een elektronische studio" in Nederland (Contact organization for the establishment of an electronic studio in the Netherlands) was held on October 12, 1956, in Restaurant De Poort van Kleef in Utrecht. Most of the organizations Maas had asked to participate had agreed to do so. At the meeting, Maas, Huydts, Kok and Vermeulen were appointed as members of an executive committee, which was to concentrate on establishing and equipping the studio, financial planning and logistics.

A second assembly took place on December 18, 1956 at the AVRO studio in Hilversum. By now, an impressive list of Dutch organizations had agreed to take part in the Contactorgaan: the authors' rights organizations BUMA and STEMRA, the music publisher Donemus, the Genootschap van Nederlandse Componisten (GeNeCo) (Dutch composers' association), the Koninklijke Nederlandse Toonkunstenaars Vereniging (Royal Dutch musicians' union), the NRU, Philips Research Laboratories, the Technische Hogeschool Delft, the University of Amsterdam's phonetics laboratory, and of course Gaudeamus.<sup>36</sup> Maas had clearly tried to create broad support for his plan, which would certainly be necessary when governmental support was requested in the future. But the large number of organizations involved would prove to have its disadvantages.

## Defining Electronic Music and Staging the First Concerts

At the second assembly of the Contactorgaan, its members were asked to formulate their ideas regarding a definition of electronic music and send them to the chairman.<sup>37</sup> The topic was to remain on the agenda for the next three assemblies. To a reader of the minutes, the discussions about definitions might seem somewhat tiring, but one must remember that electronic music was still a largely unknown phenomenon in the Netherlands in early 1957. Electronic sound material had played only a marginal role in Badings' and De Leeuw's radiophonic pieces, and the only true Dutch electronic music to have been produced so far was Badings' ballet music *Kain en Abel*. A contact organization for electronic music therefore had to be able to give a clear definition when asked to do so, e.g., when it was applying for subsidies. On the other hand, one could argue that trying to define electronic music before a studio even existed was objectionable. According to the composer Jan Boerman, a definition, if needed at all, should result from practical experiments in the studio. Finding out the nature of electronic sound material was his main motive for becoming active in the electronic music studio in Delft in 1959.<sup>38</sup>

Roelof Vermeulen was the first to formulate a definition, although he decided to do so for "electro-phonetic" rather than "electronic" music. He presumably preferred that term as a way of including both French *musique concrète* and German *elektronische Musik*, which had different theoretical points of departure. Vermeulen mentioned the composer's intention in the first sentence of his definition, but for him, whether or not a composition could be regarded as "electro-phonetic music" seems to have depended mainly on the use of certain techniques and not on the compositional approach. And he seemed to define the composer's intention in primarily technical terms as well. According to Vermeulen, music could be called electro-phonetic if the composer presented it to the audience by means of an audio recording (magnetic tape, sound film, phonograph record, etc.) and electronic equipment had been used in its production for purposes other than "faithful reproduction." The mere use of an electric guitar, Hammond organ, trautonium or another directly played instrument, regardless of the use of electroacoustic techniques, did not count.<sup>39</sup>

At its third assembly, on January 23, 1957, the Contactorgaan decided to invite the two Prix Italia winners Henk Badings and Ton de Leeuw to a plenary meeting as additional advisors. There, the definition of electronic music would be further discussed.<sup>40</sup> Kok wrote his contribution to the discussion on February 9. It did not add much to Vermeulen's earlier definition, except that Kok said electronic music was distinguished from instrumental music by its artistic aim. According to Kok, by modifying recorded material with electronic processes in manifold ways, one could obtain a succession of sound complexes during reproduction that was impossible to achieve with traditional musical instruments.<sup>41</sup>

The announced plenary meeting of the Contactorgaan took place on March 15, 1957, but in spite of the invitation, Badings and De Leeuw did not come. De Leeuw had agreed to become



an advisor to the organization, however, while Badings had not yet given a decisive answer. The members of the Contactorgaan took notice of the most recent version of the definition, which was the result of the merging of various proposals followed by deliberation and subsequent changes. It was decided that Huydts, Kok and Vermeulen would develop the definition further together and present it for approval at the next assembly.<sup>42</sup> Shortly after the plenary meeting, De Leeuw wrote that electronic music was that which – whatever sound sources it was based on – used electroacoustic means in an autonomous way and was bound to a mechanical reproduction. Such autonomous use of electroacoustic means excluded all forms of electronic arrangements of traditional music. De Leeuw made some further remarks, for instance, that the “German, French and other definitions are too goal-oriented to be generally acceptable,” and ended by suggesting that a different name than “electronic music” might be desirable.<sup>43</sup>

One could say that these attempts to formulate a definition of electronic music generally seem to incorporate both the German and the French approaches, at least on a practical level, which, according to Maas and co., was partly an illustration of the Netherlands’ geographical position between those countries. And the term “electronic music” was thus apparently considered inappropriate, since it referred much more to the German approach than to the French one.

The Contactorgaan held its fifth assembly on April 16, 1957. Badings had by now agreed to be an advisor, but again, neither he nor De Leeuw attended the meeting. The organization’s original full name was now changed to Contactorgaan Elektronische Muziek (Electronic music contact organization) (CEM), with the term “electronic music” given the following definition, which had been critically reviewed by the members of CEM:

Electronic music emerges from the reproduction of artistically montaged fragmentary recordings, which have been obtained with magnetic tape recorders or other sound recording devices; these recordings can be made from natural sounds or synthetic vibrations produced with electronic or mechanical-electronic devices, or they can consist of combinations of both sources that may or may not have been modified beforehand.<sup>44</sup>

The decision to change the name was made after it became clear that CEM should not only investigate the desirability and possibility of founding an electronic music studio but should also act as a promoter of electronic music more generally. Indeed, CEM’s involvement in programming electronic music at concerts and festivals had become an important part of its activities soon after its establishment. In March 1957, for instance, the Contactorgaan had been asked by Peter Diamand, the secretary of the Holland Festival, to give advice regarding electronic music demonstrations at the upcoming edition of the festival.<sup>45</sup>

The first Holland Festival had taken place in 1948, and it had almost immediately become one of Europe's most important festivals of music, theater and dance. One of the main sponsors in those years was the Philips company, represented in the festival organization by Frits Philips and H. J. R. G. Hartong. The director of the NRU, J. Broeks, was also a member of the festival's board of directors.<sup>46</sup> Both Philips and the NRU were represented in CEM, which presumably explains why it was approached by the festival so soon after its founding.<sup>47</sup>

The proposed concert program sent by the Contactorgaan to the Holland Festival in March 1957 was based on three considerations: the program should not exclusively contain loud-speaker music and should introduce visual elements by means of film and ballet; the different schools in the electronic music field should be represented; and the program should contain compositions from as many different countries as possible. The works on the proposed program were: *Notturmo*, by Bruno Maderna (Italy), or *Dimanche noir*, by Pierre Henry (France); *Studie II*, by Karlheinz Stockhausen (Germany); *Séismogrammes*, by Henri Pousseur (Belgium); the last part of *Symphony of the Birds*, by Jim Fasset (USA); the film *Masquerage*, by Max de Haas, with music by Pierre Schaeffer (France); and excerpts from Ton de Leeuw's *Job*. After an intermission, *Kaïn en Abel* could be performed by the Nederlands Ballet, under the direction of Sonia Gaskell, with music by Badings,<sup>48</sup> who was willing to give introductions to the various pieces.<sup>49</sup>

The program was considered very attractive by the Holland Festival, and although it turned out to be much more expensive than the original budget allowed for, the board wished to realize it.<sup>50</sup> It gradually became clear, however, that the Holland Festival was under the impression that CEM itself would organize the event, which it was not willing to do. Moreover, De Leeuw refused to have excerpts from *Job* performed.<sup>51</sup> Time was running out, and although the Nederlands Ballet had been contacted, it was finally decided that the electronic music concert would be postponed until the 1958 Holland Festival.<sup>52</sup>

At CEM's eighth assembly, a new concert possibility was discussed, after Vermeulen reported that the Philips Schouwburg<sup>53</sup> in Eindhoven was a potential venue. Maas and Vermeulen were appointed by CEM to come to an agreement, using the program that had been proposed to the Holland Festival as a starting point.<sup>54</sup> This time, the proposal was successful. It was decided that a concert would take place on November 16, 1957, and the program was finalized at CEM's next meeting on October 23 in the assembly hall at the AVRO studio in Hilversum.

The concert, announced in various newspapers as the very first concert of electronic music in the Benelux, consisted of the following elements:

- |                                     |                          |
|-------------------------------------|--------------------------|
| 1. Spoken introduction by           | Henk Stam (CEM chairman) |
| 2. <i>Étude aux chemins de fer</i>  | Pierre Schaeffer         |
| 3. <i>A Piece for Tape Recorder</i> | Vladimir Ussachevsky     |
| 4. <i>Notturmo</i>                  | Bruno Maderna            |

5a. Introduction to <i>Job</i> by	Ton de Leeuw
5b. <i>Job</i>	Ton de Leeuw
–Intermission–	
6. <i>Gesang der Jünglinge</i>	Karlheinz Stockhausen
7a. Introduction to <i>Kain en Abel</i> by	Henk Badings
7b. <i>Kain en Abel</i>	Henk Badings

Additionally, Philips proposed playing the popular works “Song of the Second Moon” and “Night Train Blues,” by Dick Raaijmakers’ alter ego, Kid Baltan, during the intermission. Both pieces had been produced earlier that month and played at the CEM assembly in Raaijmakers’ presence. It was decided, however, that no music would be played during the intermission. Stockhausen was willing to come to Eindhoven in person on the condition that four-channel playback of *Gesang der Jünglinge* was possible. Philips promised to make arrangements,<sup>55</sup> but by the time of the CEM concert in Eindhoven, it did not yet have equipment for playing four-channel tapes. (It would, in fact, not be until August–September 1958 that the first piece was produced on a four-channel 1-inch tape machine at the Philips Research Laboratories studio: Henk Badings’ *Dialogues for Man and Machine*.)<sup>56</sup> But Stockhausen’s presence was apparently so greatly desired that money was found to bring him from Cologne along with the necessary equipment and two technicians from Westdeutscher Rundfunk (WDR), one of NWDR’s two successors.

Badings’ *Kain en Abel* was to be performed just as it had originally been conceived, with one channel from a directional group of loudspeakers at the front of the hall and the second channel diffused through the nondirectional loudspeakers of the electronic reverberation system in the ceiling. In an attempt to do Stockhausen a favor, Raaijmakers – who was responsible for the audio engineering in the Philips Schouwburg that night – made additional connections from the outputs of WDR’s four-channel machine to the hall’s reverberation system, so that the loudspeakers on the ceiling could be used along with the speaker groups surrounding the audience. However, during the performance, Stockhausen turned the levels up much higher than he had done during the sound check. Much to his displeasure (and Raaijmakers’ embarrassment), the reverberation loudspeakers caused the whole ceiling to resonate.

Another thing that annoyed Stockhausen was the music of Kid Baltan.<sup>57</sup> In spite of the decision made at the CEM assembly, Philips



Fig. 3.2: Ton de Leeuw, Karlheinz Stockhausen, Edgard Varèse and Walter Maas after the CEM concert in Eindhoven on November 16, 1957.

included the popular works in the concert after all. The intermission ended with Baltan's pieces, played in the hall itself. In effect, it was as if the second half of the concert began with "Song of the Second Moon."<sup>58</sup>

Varèse had been in Eindhoven since September 2, 1957, for studio work on *Le poème électronique*, and he was present at the concert, though none of his compositions were on the program. Stockhausen and Varèse had not met since Stockhausen had played the tape parts of Varèse's *Déserts* at the December 8, 1954, performance in Hamburg. Raaijmakers remembered how the two composers were so eager to discuss their music with each other that they had hardly spent time talking to anyone else.<sup>59</sup>

In February 1958, CEM held a new meeting with Holland Festival secretary Diamand and Bomli of the NRU. Its intention was to present a program for the festival's 1958 edition, with concerts in Amsterdam and Scheveningen.<sup>60</sup> CEM was asked to come up with a new proposal, but it was unable to do so before early May, since Badings had left for South Africa in January and the new program would have to be discussed with him.<sup>61</sup> Diamand understood the difficulties CEM faced, but a delay would make it impossible to list the performances in the festival brochure. As a result, the board might decide to remove the concerts from the program.<sup>62</sup> CEM had been corresponding with WDR in Cologne, Radio Diffusion Française, the Belgian National Institute for Radio Broadcasting (NIR) in Brussels, and the electronic music studio in Milan about the concerts, but if listing details was a condition for their taking place, as far as CEM was concerned, all further attempts to come to an agreement might as well stop immediately.<sup>63</sup>

When Badings returned from South Africa, he suggested having around thirty minutes of music by Italian, German, American and French composers before the intermission, followed by his own suite from *Mens en Machine*. The program would end with the animated film *Variations électroniques*, whose soundtrack was also electronic music by Badings.<sup>64</sup> His proposal was, of course, shamelessly egocentric, and the whole situation was typical of Badings' dominance at the time. Why else would CEM have had to wait to make its proposal to the Holland Festival until he returned from South Africa? And why would the final proposal consist of a program in which works by important composers from Germany, France, Belgium, the USA and Italy served merely as a curtain-raiser for Badings' music? But in the end, the proposal came too late. Diamand expressed regret that the electronic music program would once again have to be canceled, but without proper publicity, the risk of the concert taking place in an empty hall was considered too high.<sup>65</sup>

In January 1959, the possibility of staging electronic music concerts at the next Holland Festival was once again on the agenda of the CEM assembly. The festival was considering holding concerts in Amsterdam and The Hague, this time with spoken introductions by Pierre Boulez, and had contacted CEM to ask for its input.<sup>66</sup> CEM replied with a proposal. A month later, CEM had not heard from the Holland Festival and therefore set a deadline of March 15 for its response.<sup>67</sup> An answer was promised but not received before the deadline, so CEM decided to refrain from cooperating with the festival organization.<sup>68</sup>

In spite of all the efforts that had been made, after the premiere of Badings's *Kain en Abel* in 1956, it was not until 1960 that the Holland Festival program again featured electronic music. That edition of the festival opened with Badings' opera *Martin Korda D.P.* ("D.P." stands for "displaced person"). The electronic music in the first scene of the third act was made in the studio at Philips Research Laboratories. The festival also premiered De Leeuw's *Antiphonie* for wind quintet and four electronic tracks; these tracks were also produced at Philips Research.<sup>69</sup> However, while Badings and De Leeuw were both advisors to CEM, the performances were not mentioned in any of the very detailed minutes of its assemblies. Apparently, CEM was not involved in organizing these concerts.

## The International Days of Experimental Music at the 1958 World's Fair

In spite of all the setbacks, there were successes too. At the CEM assembly on October 23, 1957, it was mentioned that Dutch applications would be accepted for a concert series at the 1958 World's Fair in Brussels.<sup>70</sup> In advance of the assembly of February 7, 1958, the members of the CEM therefore received a prospectus for the International Days of Experimental Music, planned for October 5 to 10 as part of the World's Fair and organized by the Belgian National Institute for Radio Broadcasting (NIR). CEM decided to propose contributing an electronic music evening in the spirit of the Eindhoven concert. It would offer its services to the committee in charge of Dutch submissions. It also considered its presence at the experimental music days to be important in itself.<sup>71</sup> The NIR had written that to be eligible for a position, CEM needed to write to the secretary of the experimental music days. Maas, as was typical of him, telephoned Belgium during the assembly and managed to reserve a one-hour slot for CEM's contribution. The concert program was discussed further with CEM advisors De Leeuw and Badings.<sup>72</sup> The proposal that followed included Badings' *Kain en Abel*, the suite from *Mens en Machine*, the film *Variations électroniques*, and a to-be-determined work by De Leeuw.<sup>73</sup> The list of works changed later, and instead of an hour-long slot filled exclusively with Dutch contributions, these works were added to programs of pieces from electronic music studios in Europe and the United States.

The impressive program of the International Days of Experimental Music gave a



Fig. 3.3 and 3.4: French and Dutch versions of the program for the International Days of Experimental Music.

broad overview of contemporary instrumental and electronic music.<sup>74</sup> It started with a lecture by Pierre Schaeffer, which was followed by a concert of fourteen *musique concrète* works, including the interpolations of organized sound from Varèse's *Déserts* and the premiere of Xenakis' *Diamorphoses*. In the evening, ballets were performed by Maurice Béjart, accompanied by *musique concrète* by Pierre Henry and Pierre Schaeffer. The next day, San Francisco's Audio-Visual Research Foundation gave a concert in the planetarium in the Alerteum Palais de la Science. The festival continued with more lectures, including one by Henk Stam about the activities of CEM.

A concert of *elektronische Musik* (as opposed to *musique concrète*) produced in studios in Belgium, Germany, Italy and the Netherlands was given in the grand auditorium on the afternoon of October 7 and again in the evening. The program began with the premiere of Badings' *Genese*. Next was De Leeuw's serial composition *Elektronische studie*, followed by works from Belgian electronic music studios NIR and APELAC; Werner Tharichen's *Musik auf Pauken*, from the Technische Universität Berlin; Gottfried Michael Koenig's *Essay*, György Ligeti's *Artikulation* and Stockhausen's *Gesang der Jünglinge*, all from WDR in Cologne; and Luciano Berio's *Thema (Omaggio a Joyce)* and Bruno Maderna's *Continuo*, from RAI in Milan. The following day saw more lectures by Meyer-Eppler and Eimert, Badings, Berio and Stockhausen. The last day featured presentations of functional music for radio, theater and film, including two more contributions from the Netherlands: Badings' *Dialogues for Man and Machine* and the radio cantata *Amsterdam* by Hans Lachman (1906–1990).<sup>75</sup>



Fig. 3.5: Composers at the International Days of Experimental Music, from left: John Cage, Henk Badings, Mauricio Kagel, Earle Brown, Henri Pousseur, Luciano Berio, Marina Scriabine, Luc Ferrari, Pierre Schaeffer, Karlheinz Stockhausen (seated).



Both Badings' works were played from four-channel tape, and they were in fact the first four-channel works produced at Philips Research Laboratories. De Leeuw's *Elektronische studie* was originally produced in mono at the NRU in 1957 but had been reedited as a four-channel composition at Philips. In this version of *Elektronische studie*, each sound is placed on one of the four tracks and therefore remains in the same position in the hall during playback. In Badings' two works, however, the sounds constantly crossfade from one channel to the next, thereby creating the illusion that they are moving around the auditorium. While the four-channel format was a novelty for Philips Research, it certainly wasn't new as such. In Cologne, four-channel works had been produced since 1955, and Koenig's *Klangfiguren II* and Stockhausen's *Gesang der Jünglinge* had premiered on four-channel tape in May 1956.

On the other side of the Atomium, in the Philips Pavilion, an unsurpassed Dutch sound spatialization system for electronic music was being presented at the fair. But painfully enough, the music being played on it wasn't Dutch: it had been composed by the French-American Varèse and the Greek-French Xenakis. For Roelof Vermeulen, a founding member of CEM and a promoter of Badings' electronic music, it must have been hard to accept that his company's pavilion housed the most advanced system ever for the spatial reproduction of electronic music without involving any Dutch composers. This situation provides yet another reason for the rivalry perceived by Varèse and Raaijmakers between the Philips Research Laboratories electronic studio and ELA's Philips Pavilion project (see Chapter 5, 147–52).

The November issue of *Mens en Melodie* contained a review of the International Days of Experimental Music by Ton de Leeuw that was almost three pages long. According to De Leeuw, there had been such an overwhelming number of concerts and lectures that it had been impossible to concentrate on individual compositions. Discussing the Dutch contributions, he wrote that Badings and Lachman demonstrated strong connections with tradition and did not accept the technical-aesthetic insights of the avant-garde; on the contrary, they both tried in very different ways to "integrate the new technical means into the entirety of classical-romantic patterns."<sup>76</sup> The concert of *musique concrète* had shown potential, but for De Leeuw, the ideals formulated by Schaeffer had not been realized yet. His impression was that after Schaeffer, no other figure of importance had yet stepped forward, and within the context of experimental developments as a whole, the productions made at Schaeffer's Club d'Essai were of little significance. The concrete music accompanying the ballets had greatly disappointed De Leeuw. His main objection to the program of the Audio-Visual Research Foundation was that he saw no correlation between the sounds and the imagery. In connection with this, De Leeuw addressed *Le poème électronique* in the Philips Pavilion:

"Whereas the Americans [of the Audio-Visual Research Foundation] had shown mainly abstract tendencies, here, images were presented of gorillas, machines and human crowds, while the music also made extensive use of illustrative effects. I had expected more from Edgard Varèse, the composer of *Déserts*; much

more, in fact, taking into account the unique opportunities Philips had offered for the realization of this work [which it had not offered to the composers of CEM]."<sup>77</sup>

It is certainly true that compared to Paap's articles in the same magazine, this review by De Leeuw offers a much less prejudiced reflection on electronic music and avant-garde music in general. As opposed to Paap's biased comments on modernist music, De Leeuw's critique of Badings' traditional approach is well-considered. But in retrospect, his judgment of the *musique concrète* concert is surprising. After all, that concert had included the premiere of Xenakis' *Diamorphoses* and excerpts from Henry and Schaeffer's *Orphée 53*, two works that established positions of general importance in the history of electronic music. At the time of his review, De Leeuw's only contributions to the electronic repertoire were his radiophonic oratorio *Job*, with its somewhat arbitrary use of sonic effects, and *Elektronische studie*. Compared to the electronic pieces coming out of Cologne and Milan around that time, the latter work is rather primitive in both formal conception and technical execution. After hearing *Elektronische studie* presented along with pieces by Stockhausen, Maderna, Berio and Ligeti, De Leeuw might have wondered whether it was appropriate for him to review these concerts in the first place.

CEM's next assembly took place five days after the International Days of Experimental Music ended. Henk Stam, who had attended the concerts in Brussels, reported back to the members. In general, he said, CEM had been so willing to participate that in the end things had been too forced.<sup>78</sup> What he meant is not explained further in the minutes, but from the program containing the pieces by Badings and De Leeuw, it appears that it must have become evident to Stam that the Netherlands was far behind in compositional achievement in comparison to France, Germany and Italy. After all, clearing that backlog had been one of CEM's arguments for trying to found an electronic music studio for composers.

## Chapter 9

### A Temporary Studio for Electronic Music Education and Production

#### A Studio at Technische Hogeschool Delft

Walter Maas had visited the acoustics research group at the Technische Hogeschool Delft on May 2, 1956, even before the establishment of the Contactorgaan in July that year, and had come to the conclusion that the college was the place with the most potential for establishing

an electronic studio for composers. TH Delft, represented by Willem Kok, was a member of the Contactorgaan from the beginning. Although establishing a studio was the Contactorgaan's primary goal, it was not until March 1957 that it sent a letter in support of this to Hendrik Jan Reinink (1901–1979), secretary-general of the Netherlands Ministry of Education, Arts and Sciences.<sup>79</sup> The letter stated that the Contactorgaan had been founded after a discussion initiated by the Gaudeamus foundation about the desirability of an electronic music studio. The letter mentioned that young Dutch composers had been commissioned to compose electronic music works but were unable to accept the commissions because they lacked necessary skills and/or a place to work.<sup>80</sup> The Philips Acoustics Laboratory (*sic*), the letter said, had been able to offer help on one occasion, but this help had remained incidental.<sup>81</sup> The Contactorgaan explained that the studio it wanted to make available to composers would have two objectives: to establish study opportunities for composers and to create an environment where composers could realize electronic music commissions. The Contactorgaan was convinced that the permanent establishment of a studio should be achieved gradually, with its desirability and possibility first made clear to interested circles through practice. Until then, a temporary solution should be found. TH Delft already had a small studio,<sup>82</sup> for which Philips was willing to donate some equipment. The Contactorgaan asked the Ministry to make a request on its behalf to TH Delft's board of governors that a temporary electronic music studio be installed in this transition period, perhaps eventually leading to the establishment of a permanent studio.<sup>83</sup>

Reinink was indeed willing to intervene at TH Delft.<sup>84</sup> On behalf of the Ministry, he asked the governors to give the composers recommended by the Contactorgaan temporary access to a studio, so that through trial and error, it could be determined whether an independent studio for electronic music was desirable and possible. The board of governors replied that the department of technical physics had enough equipment available to investigate the viability of the Contactorgaan's plans. However, they commented that it was difficult to predict the magnitude of the applicability of electroacoustic means in the production of "artistic sounds." Additionally, should there be reason to found a permanent "electroacoustic center" in the future, they wondered if that center shouldn't be accommodated elsewhere.

The Ministry believed that such a center could be established only with the help of electroacoustic experts and technicians and that its development would initially be research-oriented. But TH Delft considered the interest of education in the project, if any, so distantly secondary that permanent accommodation at the college was undesirable. Since TH Delft had the space and equipment for an initial setup, however, the governors were willing in principle to give the Contactorgaan access, starting with a period of a year. After that year, the Contactorgaan was to hand in a report of its achievements, on the basis of which a decision would be made as to whether to continue or not.<sup>85</sup>

The administrative director of TH Delft asked Kok to draft a financial plan for the use of the studio, but Kok did not want to do so before consulting the members of the Contactorgaan,

by now called CEM. The topic triggered an extensive discussion at CEM's assembly on fees for use of the studio, whether students should get free access, whether commercial music production should be charged at a different rate, whether travel costs would be compensated, whether there would be grant possibilities, whether technical assistance would be offered, who would own the tapes, where the boundary was between students and composers, what admission requirements would be, and so on.<sup>86</sup>

The guidelines defined by the ministry were generally followed and confirmed by TH Delft in August 1957. If CEM wanted to extend the arrangement, it should make a request in advance of the end of the term.<sup>87</sup> The arrangement between CEM and TH Delft would indeed be extended several times, after which the decision to close the studio was eventually made in late 1960.

On September 14, 1957, CEM informed composers that they would now have the opportunity to take lessons and carry out commissions in an electronic music studio. They were invited to an introductory presentation by Kok on September 28, 1957, at the Technische Hogeschool at Mijnbouwplein 11 in Delft.<sup>88</sup> A national press release drew substantial notice, and the lecture hall at TH Delft proved too small for the seventy-plus people who came to the meeting. One of them was Edgard Varèse, who had just started work on his music for the Philips Pavilion. At the formal opening of the studio in Delft, Varèse's instrumental work *In-tégrales* was played to the audience on phonograph record. Examples of the cynicism with which contemporary and electronic music were discussed in the serious press in the Netherlands have already been given (Paap's articles in *Mens en Melodie*). Now the composer and music critic Jan Mul (1911–1971) expressed his disapproval in a major Dutch newspaper, *de Volkskrant*:

The invention of sound recording tape has created the possibility of producing the most unrestrained sounds through loudspeakers. This is called "electronic music." [...] The advantages of electronic music are enormous: orchestras will become obsolete, and so will conductors; conservatories can close their doors. [...] Meanwhile, the dangers of this pet project of young composers must not be overrated. True composers will soon discover that there is more music to be found in a badly played mandolin, and they will find that it is completely unnecessary to distort a tone using electronic devices. The type of bizarre sounds that can be achieved using normal musical instruments could be heard on a phonograph record of a 1926 work by the 71-year-old [*sic*] Edgard Varèse, who honored the inauguration of the studio with his presence. Dr. Maasj [*sic*], the father of the so-called Gaudeamus composers, shouted with joy that this electronic studio gave the Netherlands a future again. Thank goodness!<sup>89</sup>

Although Willem Kok was interested in music, he was primarily a physicist. He had written a dissertation about tuning systems for organs entitled “Harmonische Orgels” (Harmonic organs), for which he had received a doctoral degree in January 1955. Kok had started at TH Delft as an assistant and later become the engineer-custodian of the Laboratorium voor Technische Physica (Technical physics laboratory).<sup>90</sup> He began giving introductory technical lessons in the electronic music studio on Saturdays, and by December 1957, seventeen composers and four TH Delft physics students were working there in small groups on a weekly basis. As a result, the studio’s schedule was almost immediately full. The equipment used to set up the studio was borrowed from Cornelis Willem Kosten’s acoustics research group, while the NRU supplied the magnetic tape reels needed to record the experiments. Although TH Delft had a serious problem with space, the room that housed the electronic music studio was unwanted by anyone else. The reason was that there was a large ventilator in it that stayed on all day and made a constant humming noise. One might think this would be an unsurmountable obstacle for a music studio, but apparently, CEM was so eager to get started that it accepted these circumstances.

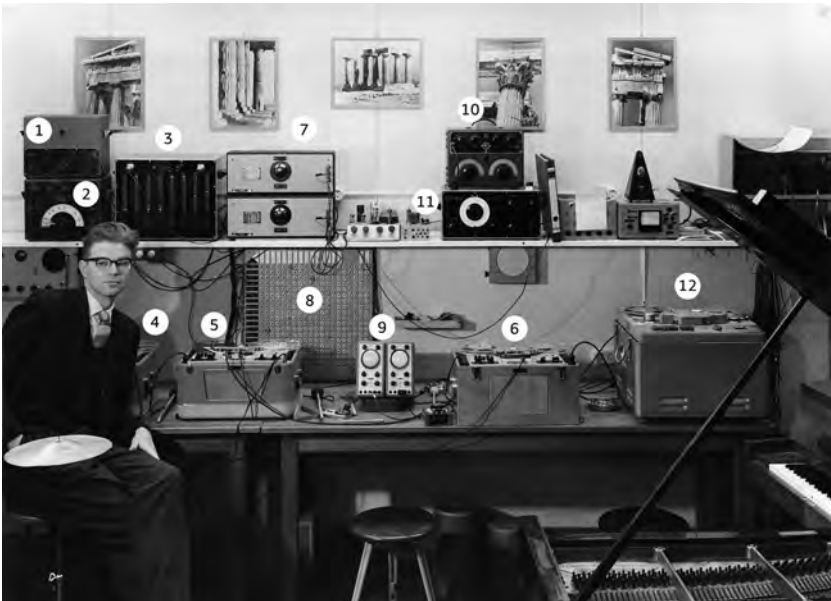

*Fig. 3.6: Peter Schat in the electronic music studio at Technische Hogeschool Delft, January 1959. Equipment included a Peekel noise generator (1); a Peekel sine wave generator (2); a Peekel TF823 multi-octave filter (3); Revox A/B 36 mono tape recorders (4, 5, 6); two Siemens Oktavsieb filters (7); a patch field (8); two Philips GM5655 oscilloscopes (9); a Philips GM3207 sine wave generator (10); a Peekel function generator (11); and a Telefunken M5 stereo tape recorder (12). The studio also had a ring modulator (connections visible on close inspection of patch field in photo, but device has not been identified).*

Apart from the series of introductory lessons by Kok, the people working in the studio had no technical experience at all. Nevertheless, the studio in Delft operated on the basis of composers' self-activation, whereas at Philips and the NRU, composers acted more as conductors who gave instructions that were executed by trained technicians. However, in Delft it soon became apparent that it was exceptional to find both musical and technical skills combined in one person. As a result, six months after the opening of the studio, the number of composers had dropped to around ten, while the number of TH Delft students had increased to fifteen. This group of students was now receiving additional lectures on electroacoustics from Kok almost weekly.

By December 1957, Kok reported to the members of the CEM that a technically skilled staff member was considered necessary in the studio. He suggested Dick Raaijmakers, who had been present at his first series of introductory lessons. Kok's choice was remarkable, since so far Raaijmakers had only assisted Badings, with Jan de Bruyn, during production of *Variations électroniques* in August 1957 (see Chapter 3, 72–7) and produced two popular electronic works, which had been performed at the CEM concert in Eindhoven on November 16, 1957. After De Bruyn was transferred to Philips' ELA division, Raaijmakers became Badings' main assistant, but at the time of Kok's request, Badings had produced no new works since *Variations électroniques*. Although Vermeulen considered lending Raaijmakers out to Delft periodically,<sup>91</sup> Raaijmakers stayed in Eindhoven until the Philips studio moved to Utrecht in November 1960. He never worked on his own music or assisted another composer in the Delft studio.

One should not judge the importance of the Delft studio and Kok's influence solely by looking at the studio's direct artistic output but by taking into account the extent to which the experience of composers who worked there influenced future developments in the Netherlands. Among the composers attending Kok's first sessions was Jan van Vlijmen, though he soon quit. Another was Misha Mengelberg (1935–2017). Although Mengelberg kept attending Kok's lectures and stayed on the studio's schedule for several years, he never completed an electronic work in Delft. A third Dutch composer to pass through the studio was Peter Schat.<sup>92</sup> Van Vlijmen, Mengelberg and Schat would be involved in the 1969 founding of the Studio for Electro-Instrumental Music (STEIM) in Amsterdam, along with Konrad Boehmer (1941–2014), Dick Raaijmakers, Louis Andriessen (\*1939) and Reinbert de Leeuw (1938–2020). STEIM still exists today and is one of the world's leading institutes working in the field of hardware and software development for live electronic music.

## Electronic Music for Film and Theater

The studio in Delft was the result of an effort to support the needs of composers from contemporary music circles, who usually presented their works in traditional concert settings.



But most of the electronic music produced in Delft in 1957 and 1958 was not autonomous; rather, it was made for plays, films and ballets. Electronic music for film was becoming fashionable. Badings composed two electronic soundtracks in 1957,<sup>93</sup> and Raaijmakers made electronic music for two Philips films in 1960.<sup>94</sup> His "Song of the Second Moon" had been used in the cinema<sup>95</sup> as well; the director Han van Gelder, who had applied electronic sounds in his 1953 tabletop animation film *The Conquered Planet* at Toonder Studios (see Chapter 3, 72–7), used the Delft studio in May 1958 to create an electronic soundtrack for a scene in Bert Haanstra's (1916–1997) *Glas* (Glass). This ten-minute film shows glassblowers at work, followed by the manual fabrication of various glass objects, in scenes accompanied by the relaxed music of a jazz combo.<sup>96</sup> Halfway through the film, however, the subject changes from these human actions to the fully automated and rhythmic manufacture of glass bottles, and for two minutes the music becomes electronic.<sup>97</sup> Obviously, the sounds are meant to illustrate the dehumanization of the production process.

Another film that used electronic music in contrast with the comforting sound of traditional instruments is *Paleontologie: Schakel met het Verleden*, also known as *Story in the Rocks: An Introduction to Palaeontology*, commissioned by the Royal Dutch Shell Group and directed by Han van Gelder.<sup>98</sup> The music for *Story in the Rocks* was composed in June 1958 by Jan Masséus (1913–1999), who had studied composition with Badings. Masséus was one of the composers given access to the studio in Delft after recommendation by CEM. Here again, the scenario features distinct cuts, emphasized by strong contrasts in the music. After ten minutes, during which the work of scientists in the field of paleontology is explained, the camera follows the contours of huge dinosaur skeletons in closeup for more than a minute. During this scene, the voiceover stops and electronic music takes over. But the most important scene with electronic sounds comes some time later. After a sequence of scenes including only real-life images, three minutes of tabletop animation impressions of prehistoric landscapes appear. The alienating effects of these landscapes and the total absence of the human race are enhanced by the use of electronic background music. Moving from the Carboniferous to the Triassic, then the Jurassic, the Cretaceous, the Tertiary and the Ice Age, the film finally arrives at the image of a human footprint and the cave paintings at Lascaux as witnesses of the presence of human beings. It is exactly at this point that the music changes from electronic back to instrumental.

Electronic music also found its way into the world of the theater. Four of the electronic works produced in the Delft studio in 1957 and 1958 were commissioned by Toneelwerkgroep Test (Test theater study group). Founded by the actor and stage director Kees van Iersel (1912–1998) in 1956, Test was the first theater group to bring the repertoire of the avant-garde playwrights to Dutch audiences. The actors, who included Sieto Hoving (\*1924), Henk van Ulsen (1927–2009) and Yoka Berretty (1928–2015), were professionals who performed with Test on a volunteer basis alongside their regular work. Test staged five productions between February 1956 (Test I) and September 1960 (Test V), with plays by Eugène Ionesco (1909–1994), Hugo Claus (1929–2008), Arthur Adamov (1908–1970), Sybren Polet

**tuschinski / theater-in-het-rond**  
**toneelwerkgroep test speelt**

op de zaterdagen **29 maart** 'savonds om half elf  
**5-12-19-26 april**

**test III**

**eugène ionesco jacques of de onderwerping  
de kale zangeres**

regie: kees van iersel  
medew. els bouwman, sonja brill, marijke hoving, dini de neef, riny v. slingelandt,  
riëmke v.d. voort, sieto hoving, herbert joeks, ton lensink, willy ruys, henk v. ulsen  
geluidsmontage: marleen van hall

vooraf:  
**klankstudies** gemaakt in de studio v. elektronische muziek te delft en  
in het natuurk. laboratorium van philips in eindhoven

plaatsbespreking:  
uitsluitend op nr. 65177; donderdag, vrijdag en zaterdag van 10 tot 12 uur

DRIUK. RAVENSBERG - AMSTERDAM

Fig. 3.7: 1958 promotional poster for the Test III performances, which began with sound studies by Jan Righarts, Tymen van der Kooy and Dick Raaijmakers, made at the electronic music studio in Delft and the Philips Research Laboratories studio in Eindhoven. Design by Wim Strijbosch.

(1924–2015), Paul Rodenko (1920–1976) and Harry Mulisch (1927–2010).<sup>99</sup> One of Test's ideas was that theater needed to be released from its shoebox diorama character and become "spatial." While in music, the trend in the 1950s was to increase the spatiality of the sound by surrounding the audience with loudspeakers, Test's performances achieved spatiality by positioning the audience around the stage. Several of these performances were therefore given in the former La Gaîté, a two hundred-seat cabaret hall of the Theater Tuschinski in Amsterdam. La Gaîté was round and had a dance floor in the middle, which made it suitable for "arena theater."

The Test II program, presented in March and April 1957, consisted of two plays by Ionesco, *The Lesson* (1950) and *Victims of Duty* (1952). The latter included an electronic soundscape by Marleen van Hall.<sup>100</sup> According to a review in the weekly magazine *De Groene Amsterdammer*, her beautiful sounds expressed the "sloshing of the waters of the subconscious and the gurgling of the senses of guilt."<sup>101</sup> Van Hall's contribution to the performance is not mentioned in any catalogue of electronic music productions, and the studio in which it was made is unknown. Nevertheless, it was the first electronic work to accompany a live play in the Netherlands.<sup>102</sup> On March 27, 1958, Test III featured two more works by Ionesco with soundscapes by Van Hall: *Jack, or the Submission* (1950) and *The Bald Prima Donna* (1949). Her sound montage for *The Bald Prima Donna* is generally considered to be the first electronic music composition produced in the studio at TH Delft.<sup>103</sup>

The experiments of Toneelwerkgroep Test did not just concern the staging of its plays; Test also experimented by programming these plays in combination with other art forms. Test III began with the performance of a series of sound studies: the electronic compositions *Jan Klaassen*, by Jan Righarts (1915–1976); *Klankstudie* (Sound study), by Tymen van der Kooy; and *Klankstudie over één motief* (Sound study on one motif), by Dick Raaijmakers.<sup>104</sup> Though all three pieces had been commissioned by Test, they consisted of electronic music without additional theatrical elements. Therefore, Test III in fact contained the third concert presentation of electronic music in the Netherlands, after the concerts at Gaudeamus Muziekweek in August 1956 and in Eindhoven in November 1957.

Some months after the Test III performances, Van Hall and Van der Kooy wrote a letter to the Dutch House of Representatives' committee for education, arts and sciences, emphasizing the relationship of their theatrical experiments to spatially projected electronic music and other forms of art. They wrote the letter on behalf of themselves, Ignace Lilien (1897–1964), Coen Luders, Jan Masséus, Misha Mengelberg, Jan Righarts and Peter Schat – all composers who had been recommended by CEM for work in the Delft studio – and Ton de Leeuw, a CEM advisor and the winner of the 1956 Prix Italia. According to the signees, they were concerned with a "completely new form of art":

Indeed, this new sonic and spatial art, which signifies as great a revolution with respect to traditional music as film did with respect to theater, represents a radical reassessment of aesthetic and musical values, both material and spiritual.

[...] This “different” music demands projection into space, in the round; it seeks to approach the listener from many directions. All this requires a shift in thinking, not only in the technological-scientific sense but also in the psychological and aesthetic sense. Its relationships with other art forms such as theater, poetry, dance, cinema, radio and television are thereby constantly in question.

One observes a strange similarity with the intellectual climate and procedures of modern poets, painters and other artists. Mutual contact and joint activities can lead to new and unforeseen solutions in various areas that will be highly fruitful in wide circles.

One cannot deny that there may be a “zeitgeist” driving artists all around the world from many different backgrounds together to give shape to something that is already present in the minds of many.

[...] All art needs meeting centers and focal points, where it can have a fertilizing effect and be fertilized itself.

[...]

As electronic music is largely dependent on the interplay between science and art, between physical engineers and composers, it is expected that a flourishing of this new art form can only emerge from their cooperation. Therefore, one can only hope that in the Netherlands, too, [just as in France, Germany and the United States,] an artistic and scientific climate will eventually arise in which a living avant-garde music [...] can grow.<sup>105</sup>

According to the letter, the situation was especially difficult for “young, up-and-coming composers who want to work in the field of electronic music.”<sup>106</sup> The equipment they needed was very expensive and impossible to obtain privately. They had to pay travel costs to go to a studio in Delft, Hilversum or Eindhoven and needed a long period of study before being able to conceive a work. But most of all, there was “no way whatsoever [for the electronic composer] to know which audience he is working for and whether or how his work will be realized.”<sup>107</sup> Therefore, the only solution in the short term was

that the avant-garde theater group Test receive the means it needs to exist, so it can begin regular performances instead of the incidental performances and sound projections that have occurred so far. Out of the existence of a true avant-garde theater, a “research laboratory for the arts” could possibly come into being.<sup>108</sup>

This requested future “research laboratory for the arts” would basically be a small theater with the necessary equipment permanently available so that the new music could be studied

through the practice of performance and reproduction and its effect on the public thereby tested. As a result, “the young composer would know for the first time for whom, why, and with whom he is working.”<sup>109</sup> Toneelwerkgroep Test’s research laboratory for the arts did not materialize, however, and its performances remained occasional.

Test IV, which featured Adamov’s play *Ping-Pong* (1955), was first performed on June 3, 1959 at the Stadsschouwburg in Amsterdam.<sup>110</sup> Its eighteen scenes were linked by electronic music by Van Hall and Van der Kooy, and although there was no real arena theater this time, the traditional performance space was altered through an expansion of the stage across the orchestra pit. There were no footlights or front curtain, and a special stage architecture had been designed by the architect Jan Rietveld (1919–1986).<sup>111</sup> Apparently, the electronic music also altered the perception of the performance space. According to a newspaper review, the generator-made sounds had “suggested a strange world, in which we live today with ideas about the symbolism of spatiality.”<sup>112</sup>

Test’s last known performance, Test V, took place on September 23, 1960, at the Kurhaus Pavilion in Scheveningen. Once more, the electronic sound montages were made by Van Hall, this time with Jaap Spek (1929–2001),<sup>113</sup> and the sound system was provided by Philips Eindhoven.<sup>114</sup> After Test disbanded, Kees van Iersel became artistic director of Toneelgroep Studio in 1962. It was the first Dutch experimental theater group to receive government funding, and it performed on a much more regular basis than Test had. Van Iersel accepted the position on the condition that Toneelgroep Studio was given its own theater. This theater was designed by the stage and set designer Wim Vesseur (1919–1977) and had a mobile stage, around which the audience sat on three sides. When the new theater opened, Toneelgroep Studio advertised it with the slogan “no curtain, no distance between you and the players.”<sup>115</sup>

It appeared that the permanent experimental theater space the Test composers had asked for had been realized after all. However, electronic music hardly featured in the performances of Toneelgroep Studio. During the first three years under Van Iersel, no fewer than 23 productions were staged, but electronic music was an element of only two. In June 1963, the group performed the play *Een groot dood dier* (A large dead animal), by Bert Schierbeek (1918–1996), at the Holland Festival. The electronic music for *Een groot dood dier* was composed by Raaijmakers and Jan Boerman, who at that time had just founded their first private electronic music studio in the Daendelsstraat in The Hague (see Chapter 11, 232–46). In 1963–1964, Boerman composed music for Toneelgroep Studio’s performance of *The Empire Builders* (1957) by Boris Vian (1920–1959).

## The Composers Jan Boerman and Rudolf Escher

Jan Boerman was a student at the Royal Conservatoire in The Hague from 1942 to 1954. He studied piano and music education under León Orthel (1905–1985) and composition under

Hendrik Andriessen (1892–1981).<sup>116</sup> His first compositions were written for traditional instruments and show traces of the influence of Béla Bartók and Willem Pijper. Boerman was certainly interested in twelve-tone techniques but had not achieved satisfactory results in applying them in his own work. Electronic sound production techniques did not particularly attract him, but his feelings changed after the choreographer Conrad van de Weetering (1929–2017) insisted the two men investigate the technologies' possibilities further. Boerman and Van de Weetering planned to create a ballet opera incorporating electronic music, but the project never materialized.<sup>117</sup> Boerman's first contact with the possibilities presented by the studio in Delft had a huge impact on his future career as a composer. Between his first electronic work, 1959's *Musique concrète*, and his last, 1997's *Ruïne*, he created an extensive oeuvre consisting almost entirely of electronic music. By December 1959, Boerman had been working in the Delft studio for approximately a year, for just four hours once or twice a week, much to his regret. He usually did so alone, and he became very familiar with the use of the equipment. According to Willem Kok, Boerman knew the gamut of tricks involving tape recorders, applications of filters, and echo and reverberation equipment, and he was one of a very few who had worked their way up from play and experimentation to making "useful musical products."<sup>118</sup> Kok had previously concluded that it was highly exceptional to find musical and technical skill combined in one person; Boerman was obviously an exception.

Boerman himself never considered his first electronic piece, the three-minute étude *Musique concrète* of 1959, an important work, but it is significant in that the sounds he created for it were reused in many of his later compositions. *Musique concrète* was followed by the more mature *Alliage* (1960), in which Boerman made extensive use of natural reverberation – not, as he said, because he wanted to create realistic acoustic spaces for his sounds to appear in but because he understood the prolongation of sound as an aspect of timbre variation.<sup>119</sup> The building at TH Delft where the studio was housed had a very long corridor, which ended in a large hall. Sound material was played through various loudspeakers in that space, picked up by microphones, and then recorded again. These recordings were further transformed through transposition, filtering, and so on, so that new aspects of timbre revealed themselves. According to Boerman, *Alliage* was a first attempt at structuring the richness of the variety of sound colors as a development over time, something that would become a general characteristic of many of his future works. After *Alliage* was finished, Boerman started work on the composition that would become *Alchimie 1961*; however, it was not completed by the time the TH Delft studio closed in 1960, and Boerman continued to work on it later at STEM in Utrecht.

The composer Rudolf Escher had considered using electronic sound material even before Boerman. Six days after the studio in Delft opened, Escher wrote to Kok, explaining that he could not yet take the financial risk of becoming involved in an electronic adventure, since he was in the middle of several unfinished commissions. However, the city of Amsterdam had com-



missioned him to compose a work for orchestra that could include electronics. Once work on that piece began, Escher wrote, he might come to the studio in Delft to find out about the possibilities that existed there. And he had another reason to value contact with Kok and his noncommercial laboratory: he planned to conduct physiological research into “the harmonic fundamentals of European music.” He was convinced that if such research was even possible, it would have to make use of electroacoustic equipment.<sup>120</sup> It was two years before Escher became involved in electronic music production. He began taking Kok’s introductory lessons and gained access to the Delft studio after recommendation by CEM,<sup>121</sup> receiving technical assistance from Jaap Spek. Escher started working on an independent electronic piece. He said it was growing organically and initially rejected the idea of working according to a pre-calculated formal design.<sup>122</sup> However, in November 1960, he was commissioned by the AVRO broadcasting company to make electronic music for a television play based on *The Long Christmas Dinner* by Thornton Wilder (1897–1975).<sup>123</sup> By then, Escher had changed his approach and unexpectedly decided to compose the piece completely serially. Although the studio in Delft officially closed on September 1, 1960, he was allowed to produce *The Long Christmas Dinner* there together with Spek.<sup>124</sup>



Fig. 3.8: The studio at TH Delft after renovation with echo device (1); amplifiers of Philips 10039 tape recorders with closed lids (2); Peekel TF823 multi-octave filter (3); Siemens Oktavsieb filter (4); Philips 10039 tape recorders (5); patch field 1 (6); Peekel TF273 third-octave filter built around Bruel & Kjaer 1610 (7); patch field 2 (8); tone gate (9); Revox A 36 tape recorders (10); Peekel noise generator (11); Philips GM2307 sine wave generator (12); Peekel sine wave generator (13); radio receiver (14); patch field 3 (15); phonograph (16); Peekel function generator (17); and Revox B 36 tape recorder with variable speed modification (18).

The decision to close the studio was made near the end of 1959, although it had undergone a considerable renovation earlier that year. Whereas the first installation of equipment had had a temporary look (see fig. 3.6), after the renovation, the studio looked as if it was meant to become permanent. Equipment that had previously been placed on bookshelves was now mounted in racks. Therefore, some of the devices' original housings had been replaced with new front panels. Other modifications consisted of the addition of three professional Philips 10039 tape recorders and a Bruel & Kjaer 1610 / Peekel TF273 third-octave filter.

Like many other devices used in early electronic music studios, the Bruel & Kjaer 1610 third-octave bandpass filter was originally designed for measurement purposes. It basically consisted of a large bank of parallel filters, which divided the audible frequency range into third-octave bandpasses. A large dial was used to select the specific bandpass filter to which the device's input and output were connected. The Bruel & Kjaer filter in the Delft studio was modified by Peekel Instruments in Rotterdam so that the sound was fed to the inputs of all the bandpass filters instead of just one, while all the outputs could be used simultaneously in any combination desired.<sup>125</sup> Especially when noises or impulses were filtered in this way, the summation of the multiple bandpasses' pitchlike outputs created augmented third chords with a strong identity. This characterizes many of the sounds Boerman produced in Delft as well as those in Spek's composition *Impulsen* (1960).

## Chapter 10

# Continuing the Work of the Philips and TH Delft Studios in Utrecht and Bilthoven

### Plans for New Studios in Utrecht and Amsterdam

The TH Delft studio closed almost simultaneously with the Philips studio in Eindhoven; both had stayed open much longer than originally intended. At the CEM assembly of March 16, 1959, Roelof Vermeulen had announced he wanted to remove the electronic music studio at Philips Research Laboratories, since it had become a company in its own right with no reason to exist at a research laboratory. He wanted a university to take over the studio (see Chapter 3, 93–8).

Notwithstanding its planned temporariness, installing a successor to the Delft studio at a university had been on Kok's mind from the beginning too, and discussions around making one possible began almost immediately. On November 26, 1957, just two months after the studio in Delft opened its doors, Walter Maas wrote to Kok inviting him to a meeting at Utrecht University, which was to be chaired by the secretary of the University's board of governors,

J. H. des Tombe. There were three points on the agenda: first, the state of affairs at CEM and the temporary electronic music studio at TH Delft; second, the desirability of having a permanent studio in Utrecht; and third, the possibility of establishing one at Utrecht University.<sup>126</sup> The university sent an official letter asking CEM for its advice on the matter on January 23, 1958.<sup>127</sup>

Both Kok and Badings wrote long comments on behalf of CEM, in which they described the current situation with respect to electronic music in the Netherlands. Kok wrote that his studio had been meant to be temporary from the start, since it was clear to him that TH Delft would not be the right environment for musicians. The studio had been installed there only for the purpose of investigating the viability of the new art form. According to Kok,

should this experiment have taken place anywhere else in the Netherlands, it would have either been very expensive or led to the wrong results because of incidental but significant side effects. The development of this new art needs to take place in full freedom, and if possible, away from commercial incentives. Although both the NRU and Philips are well equipped to enable composers to produce electronic music (much better, actually, than Delft currently is), it is nevertheless essential that the development (and flourishing) [of electronic music] takes place in a free environment where it is easy to establish contact with people active in other areas (including the arts).<sup>128</sup>

Kok said such circumstances would only be found at a university (which TH Delft was not).<sup>129</sup> In Delft, electroacoustics was not a subject of study, and if it moved in the direction of music, Kok was certain it would never become a subject at the college. He argued that a university would be a much better setting, because there, electroacoustics could make a direct contribution to musicology. Apart from musicologists, sound directors, who were needed more and more, could also be trained.

In our country, the study of the acoustics of music and of musical instruments is not practiced as an independent science. Apart from the developments in electronic music, the need for such a science is certainly present among sound directors at broadcasting, television, radio and phonograph record companies as well as with musicologists.<sup>130</sup>

Kok described how the subject of electroacoustics could become an elective in the physics department and a compulsory part of musicological education, in parallel with an educational program for sound directors. Students should become familiar with equipment such as microphones, amplifiers, loudspeakers, tape recorders, tone generators and audio networks through practicals, which could also be attended by musicians and students from the con-

servatories. In the fourth year of their studies, physicists could be required to conduct research on a musical instrument or design a new “klankkleurapparaat” (sound color device), while musicologists and sound directors could be given assignments involving the composition and recording of sounds. The students would need three studios; the cost of installation was estimated at 200,000 Dutch guilders. The presence of an electronics workshop for research and development was of crucial importance to Kok. He also considered it necessary to hire a technician and an assistant for daily maintenance of the studio and other rooms. The teaching of electronic music composition could be assigned to an instructor, and it was obvious to Kok that the person most qualified for the position was Badings.<sup>131</sup>

While Kok’s comments focused mainly on education, Badings’ concentrated on the specific compositional aspects of electronic music and its presentation to the audience. According to Badings, though electronic music was still in its infancy, its development had been so stormy that it had already established a permanent position in the arts. Its main contribution was that now, finally, the full range of audible frequencies and possible dynamics could be explored. In this way, electronic music had completed a long-term process of expansion in western music.

Musically, this creates possibilities particularly in the areas of tuning systems, timbre formation, dynamic relationships and continuous tone spectra. But in the third musical dimension, too – that of time – electronic music has opened up new possibilities. Whereas for practical reasons, traditional music must limit itself to a small number of time values and time proportions, electronic music can use any time value that lies within the range of human perception and, if necessary, apply tones, tone groups and tempi in irrational relationships.<sup>132</sup>

Badings continued by stating that it had appeared to be a disadvantage that electronic music was bound to prefabrication in studios and reproduction through loudspeakers, but on the other hand,

moving performance and interpretation from the actual “concert” to a prior composition of sound elements is something that is common in normal radio practice, and it has been proven by now that this need not harm the quality or the expressivity of the performance. And in a time when the radio, the television, the film and the phonograph play a large role in daily life, there is no need to view the loudspeaker’s indispensability in the reproduction of electronic music as a serious disadvantage. This limitation even has its positive sides. By splitting the sounds into two or more channels and reproducing these channels through groups of loudspeakers placed at different positions in the hall, one can involve the performance hall in the reproduction, set the sound in motion, and influence

the sound's directionality or diffuseness: actions that, with some exceptions (such as the trumpet behind the stage in Beethoven's *Leonore III*), are not possible in traditional music. Electronic music's connection to loudspeakers makes it the most suitable sonic material for radio, film, television and phonograph. In these cases, the creation of loudspeaker sound is the objective. In all other cases (for example, Beethoven's symphony reproduced through a loudspeaker), loudspeaker sound is a surrogate.<sup>133</sup>

An important aspect of the new studio CEM had in mind was that it should be "interuniversity," meaning that on an organizational level, responsibility for it should be shared by two or more institutions. Although Des Tombe had promised to contact other universities in December 1957,<sup>134</sup> by October 1958, he had not yet done so. The phonetics laboratory at the University of Amsterdam, represented in CEM since the latter's founding, had shown an interest in participating. Utrecht University knew this, but the University of Amsterdam had heard nothing from Des Tombe. Apparently, he wanted to make the new studio a Utrecht-only affair. CEM therefore wrote him a letter reminding him of the interuniversity character of the original plan.<sup>135</sup> Des Tombe said he understood but wanted to get permission from the governors of Utrecht University before contacting other institutions.<sup>136</sup>

Musicology professor Hendrik Eduard Reeser (1908–2002), who had represented the *Maatschappij tot Bevordering der Toonkunst* at Walter Maas' exploratory meeting in July 1956, and experimental physics professor Pieter Maarten Endt (1916–2008), both of Utrecht University, wrote Des Tombe that they welcomed the establishment in Utrecht of a university electronic music center where the technical means for composing such music would be available and its physical fundamentals could be researched. Such a center should certainly work in close collaboration with the university's physics laboratory, but the lab was currently so overcrowded that it was impossible to put the new center in its building. There were, however, plans for a new building, which would enable a close relationship between the center and the laboratory.<sup>137</sup> For now, the physics lab was willing to assist with the construction of electronic circuits that were not available commercially, and with other technical equipment.<sup>138</sup>

Besides its planned new physics building, Utrecht University was soon to acquire a large office building where the department of musicology would be housed. It now appeared that the new studio would be installed in Utrecht one way or another, and discussions of its interuniversity character ended. On the other hand, the University of Amsterdam considered opening a second, separate studio to be a possibility.<sup>139</sup>

During a meeting at the Ministry of Education, Arts and Sciences attended by representatives of Philips, TH Delft and Utrecht University, Reeser proposed that the electronic music institution to be established in Utrecht consist of a research center devoted partly to traditional instruments, an education center devoted partly to training composers of traditional music,

and a production center. In this way, the Philips studio's production activities and Delft's educational program could be integrated. Should Philips move its studio to Utrecht University and expand in this way, it would mean the end of the studio in Delft. That one had been a temporary solution from the start, with a permanent studio at a university planned for the future. Kok had always believed a university studio would have a duty to provide education and thus should not concentrate only on production. However, it soon became clear that the music center in Utrecht would be more exclusive in character. CEM realized that only a small number of invited musicians would be able to work there, and in spite of Reeser's original proposal, the university would not offer an educational program. According to Reeser, the university had no money now to take over the educational duties from TH Delft. It would not do so until 1961. For the moment, the Utrecht studio would only take over production tasks from Eindhoven.

With Utrecht not continuing the educational activities of the Delft studio, CEM had a new task. After all, its first priority had been establishing a studio for educating composers.<sup>140</sup> The studio in Delft would stay open for another year, but no new students were accepted after October 1, 1959. At the same time, plans for a studio in Amsterdam had also developed further. The phonetics laboratory at the University of Amsterdam was represented in CEM by G. L. Meinsma; he had been asked to elaborate at the February 5, 1960, assembly. He confirmed that such plans did exist but said he had to remain noncommittal on the details. In fact, the plans, developed by Rudolf Escher, were in a rather advanced state. After Des Tombe's attempts to exclude the University of Amsterdam from the development of an electronic music center, it comes as no surprise that Meinsma was reluctant to give CEM details. This might also explain why Escher's involvement in the Amsterdam studio is not mentioned in the minutes of any of the CEM assemblies.

During production of the music for the television play *The Long Christmas Dinner* in Kok's studio in Delft in November 1960, Escher wrote to Peter Schat: "I consider this a welcome opportunity to come forward as an 'electronic composer,' partly in relation to 'certain' plans."<sup>141</sup> Although the letter itself does not elaborate on these, it is evident from several other documents that he must have been referring to the establishment of a new electronic music institute that would be under his supervision.<sup>142</sup>

In December 1959, after he had started his musical experiments in Delft, Escher made extensive notes in preparation for two meetings with Hendrik Mol (1917–1980), who was about to accept a position as professor of phonetic sciences at the University of Amsterdam.<sup>143</sup> Escher had become aware of plans by the pianist and Conservatorium van Amsterdam director Jan Odé (1906–1989) to found a center for contemporary music, and he saw possibilities for establishing an "institute for phonetic, acoustic and experimental musicological research" that would position itself between Odé's contemporary music center and the University of Amsterdam. At his first meeting with Mol, Escher pointed out the relationship between electronic music and serial music and mentioned the important work that had been done in the studios in Cologne, Milan and Paris by Stockhausen, Maderna, Pousseur and others. He saw



multiple reasons to link electronic music in all its aspects to a conservatory, where compositionally gifted musicians were being trained. For Escher, a complete electronic music studio setup was essential for those doing theoretical research in the creative and “precreative” areas of music. There should be teamwork between physicists, physiologists, composers and musicologists, which was why collaboration between a university and a conservatory was the way to go. According to Escher, the studio in Delft had undoubtedly been a good first step from a practical point of view. The equipment had gradually improved, but this small single studio was unable to meet the demands of composers or of an acoustic-musicological research lab. The establishment of the studio in Utrecht had by now been announced, but Escher had serious reservations. He believed it would become a production studio, and Philips had too great an influence for him. Escher disliked the term “production”; the center he wanted would be oriented not towards production but towards composition.<sup>144</sup> His opinion was that the interest in electronic music production on the part of radio, television and industrial companies such as Philips was entirely the result of the general public’s association of electronic music with “space travel romanticism and cheap sonic effects.”<sup>145</sup> Furthermore, to Escher, making Badings a professor in Utrecht was problematic because of Badings’ personality and the character of his work.

The studio in Delft was to close as soon as the studio in Utrecht opened. Escher had therefore taken it upon himself to investigate the possibility of setting up a foundation, whose board would include representatives of the University of Amsterdam’s experimental phonetics lab, the Conservatorium van Amsterdam and CEM. It was essential for Escher that his institute’s new building accommodate a precision mechanic’s workshop, a composers’ studio, a students’ studio, several separate spaces for scientific research, and a briefing room. Silence would be paramount.<sup>146</sup>

At a second meeting, Escher told Mol that although Badings was to get a chair at Utrecht University, the Utrecht city authorities planned to establish a separate electronic music lectureship and name Ton de Leeuw as lecturer. It had become evident that CEM’s original intention to found an independent interuniversity electronic music studio with an associated educational program had been turned into a local affair in Utrecht, with no educational component for now. According to Escher, a plan that complied with CEM’s original wishes would automatically gain its approval. But at the same time, he only wanted to present his plan to CEM once it had a sufficient official and financial foundation. He wanted CEM to get the impression that its involvement was inevitable. And if necessary, he wanted the plan to be achievable without it.<sup>147</sup>

The day after his second meeting with Mol, Escher discussed things further with Odé. According to Escher, the experimental musicology to be practiced at his institute would supply a more precise foundation for the phenomenology of musical artworks of both the present and the past.<sup>148</sup> Mol accepted his position as professor of phonetic sciences at the University

of Amsterdam the next month. Presumably with Escher's plans in mind, he ended his acceptance speech by saying, "The sciences in phonetics open up a wide field. They make up an area of study that even includes music."<sup>149</sup>

## New Studios in Utrecht and Bilthoven

A consequence of Vermeulen's retirement and the end of Philips' commitment to electronic music was that CEM was no longer able to use the Philips studio's equipment for concert sound reproduction. If CEM still wanted to realize its concert plans the following season, it needed to obtain its own portable system. Gaudeamus already had some useful devices, and others were bought to form a complete set of equipment. This portable setup had its own car

and was managed by the technician Jaap Vink (\*1930).<sup>150</sup> At a CEM assembly, Kok suggested that with some small additions, the same equipment could also be used to produce and record electronic music in a studio.<sup>151</sup> This idea became the starting point for another temporary solution. Now that it was clear that the Delft studio would soon close, the Utrecht one would not yet offer a study program, and plans for an Amsterdam studio remained vague (at least to CEM), the organization decided to fill the gap by opening a small studio in Bilthoven, its own home base and that of Gaudeamus. To supplement the portable equipment, the NRU supplied two RAVAG<sup>152</sup> tape recorders and a Philips amplifier, while TH Delft lent a noise generator, a tone generator, a control amplifier, two equipment racks and a patch field. The aim was for the educational studio in Bilthoven to be ready for use by the time the production studio in Utrecht opened. De Leeuw was regarded as the obvious person to give introductions and lectures.<sup>153</sup>

Five composers were working in the Bilthoven studio by June 1961, and seven others had shown interest. Vink, at first only responsible for the mobile concert equip-



*Fig. 3.9: Electronic music studio in the garden house at Gaudeamus in Bilthoven, June 12, 1961. In the corner is a rack from the Delft studio containing, from top, a Peekel noise generator (panel without controls), a Philips GM2307 sine wave generator, an unidentified device, and a patch field. On the table are two Philips 10039 tape recorders and a Telefunken M23 tape recorder.*

ment, was now receiving a stipend to provide technical assistance at the studio.<sup>154</sup> De Leeuw said he was prepared to fulfill the role the CEM had proposed and become head of the studio, starting in October; however, his own compositional work would have priority and he would therefore be available only one afternoon a week. On the other hand, he was willing to give additional lectures at the Conservatorium van Amsterdam using CEM's mobile equipment.<sup>155</sup> But De Leeuw had to withdraw in September for health reasons. CEM considered asking Escher to take his place.<sup>156</sup>

Among the younger generation of Gaudeamus composers, Escher certainly wasn't known for his appreciation of the modernist approach to music. For example, when he said he wanted to use electroacoustic means to do physiological research into "the harmonic fundamentals of European music," he was actually referring to an attempt to find scientific proof that Schoenberg's twelve-tone technique was based on a misconception. The composer and CEM member Kees van Baaren (1958–1970) believed Escher was capable of teaching outside the limitations of his personal aesthetics. Nevertheless, the assembly decided to hold off on its final choice of studio head.<sup>157</sup>



Fig. 3.10: The BOAZ Bank building at Plompetorengracht 14–16 in Utrecht. The Utrecht University electronic music studio initially occupied four rooms on the ground floor to the right of the entrance.



Fig. 3.11 and 3.12: Installing the Utrecht University electronic music studio, November 9, 1960. Four-channel monitoring room (left), with a view into the studio (behind the glass-paned door); Dick Raaijmakers making connections in the new studio.



Fig. 3.13: Dick Raaijmakers and Leidi Kiewiet in the Utrecht University electronic music studio, April 1961. In the studio are a Philips EL3516 semi-professional tape recorder (1); amplifiers for Philips EL3509 tape recorders (2); Philips EL3509 tape recorders (3); a patch field (4); a Philips custom-built ring modulator / envelope generator (the same device previously used for the production of "Le poème électronique") (5); a Philips custom-built "characteristics molder" (6); a custom-built tape loop recorder/player (7); an ondes Martenot (8); and a Philips GM2314 impulse generator (9).

While CEM's aim had been to combine the Philips studio's production function with the Delft studio's educational function in a new interuniversity cooperation, in the end, study moved from Delft to Bilthoven and production moved from Eindhoven to Utrecht. At the end of October 1960, the Philips studio in Eindhoven was relocated to a 1921 former office building in Utrecht. It was renamed the Studio voor Elektronische Muziek, or STEM (in Dutch, *stem* means "voice") and became operational again in January 1961. STEM initially occupied just four rooms on the ground floor, which housed Vermeulen's office, a technical workshop, a four-channel playback room and the studio itself. In the course of 1961, two new technicians joined STEM's staff: Frits Weiland (\*1933)<sup>158</sup> and Wim van Kuilenburg.

Utrecht University held a press conference on behalf of STEM and CEM explaining the situation since the closure of the Eindhoven and Delft studios on June 12, 1961. The press visited both new studios that day. The press release gave CEM's definition of electronic music, followed by the remark that the definition was wide enough to include Pierre Schaeffer's *musique concrète* and the *elektronische Musik* of the Cologne school, as well as music by composers such as Badings, who went their own way.<sup>159</sup>

The studio in Eindhoven had been well equipped for production, and since Raaijmakers had agreed to move to Utrecht with the equipment, it had been possible to continue the studio's activities almost without interruption. STEM was now a joint organization of the university and Philips, with a supervisory board consisting of J. H. des Tombe, representing the university; Hendrik Casimir, representing Philips; and E. Bomli, representing CEM. Vermeulen was the general manager of STEM, and once he had less organizational work, the press release stated, he would concentrate on scientific research with the assistance of a physicist and an electronics engineer and the cooperation of Philips Research Laboratories. According to the press release, it was evident that "Henk Badings, who through his skills and imagination has provided the impetus for the Philips studio to come into being," would be given the opportunity to use the STEM studio for his students. And although strict demands had to be made regarding the skills of composers who wanted to work at STEM, the studio wished to be "careful not to exclude certain styles or genres."<sup>160</sup>

**Tom Dissevelt's *Intersection*,  
Dick Raaijmakers' *Vijf plastieken*,  
Jan Boerman's *Alchemie 1961* and  
Rudolf Escher's *Summer Rites at Noon***

In addition to composers who had been active in Eindhoven, Jan Boerman and Rudolf Escher were allowed to work at STEM now that the studio in Delft had closed. The first piece completed at STEM was *Intersection*, Tom Dissevelt's composition for electronic sound and jazz orchestra, commissioned by the AVRO broadcasting company. Raaijmakers provided technical assis-





Fig. 3.14: Record sleeve for Tom Dissevelt's *Intersection*, with Kid Baltan's *Mechanical Motions* on the B-side.

tance; it would be the last time he collaborated with Dissevelt. It would also be Raaijmakers' last appearance as Kid Baltan. *Intersection's* subtitle, *Fantasy for Electronic Sound and Jazz Orchestra*, is somewhat misleading, since it seems to denote a composition to be performed live on traditional instruments with electronic sounds on tape, like Badings' *Capriccio* for violin and tape and De Leeuw's *Antiphonie* for wind quintet and tape. But *Intersection* is a pure studio work that treats excerpts from an instrumental jazz orchestra recording as sonic raw material on an almost equal basis to the electronic sounds they are combined with.

As mentioned, Dissevelt had privately studied twelve-tone composition tech-

niques in books by Herbert Eimert<sup>161</sup> and Hanns Jelinek,<sup>162</sup> and the influence of these techniques is evident in his August 1959 electronic work "Vibration" (see Chapter 3, 80–3). Some months after the production of "Vibration," Dissevelt composed a true twelve-tone piece for AVRO radio's dance orchestra the Skymasters, for which he had been the arranger and bass player since 1955.<sup>163</sup> The composition, stylistically very different from the Skymasters' usual popular repertoire, was recorded at AVRO's studios on May 31, 1960. It is unclear whether the score was composed to be performed live with the Skymasters or whether he already intended to combine it later with electronic material to form *Intersection*, but that is what he did. The untitled manuscript certainly shows a work complete in itself, but the piece was recorded in several takes of shorter sections.<sup>164</sup> Only some parts of the complete twelve-tone piece for the Skymasters appear in *Intersection*, in an order different from that of the original score.

While providing technical assistance to Dissevelt, Raaijmakers had also started to work on a new composition of his own, which would become *Vijf plastieken* (Five sculptures). Raaijmakers had become convinced that electronics could lead to a completely new form of music, devoid of all the epic and dramatic aspects that had characterized existing music so far. According to Raaijmakers, a piece of music should be short and "should be taken like a pill."<sup>165</sup> He became inspired by the works and writings of the painter Piet Mondriaan (1872–1944) and concluded that with electronic equipment, it would be possible to make sounds that were "completely free from any behaviours of natural objects whatsoever!" Raaijmakers wanted to create compositions that had nothing to do with sonic impressions explained in terms of perception.<sup>166</sup> And he now also rejected the use of artificial reverberation, since it created a spatial



The image shows a page of handwritten musical notation for a twelve-tone composition. The score is organized into systems of staves. The instruments listed on the left are Alto Saxophone (Alto S), Tenor I, II, Bassoon, Clarinet (Clar), Alto Saxophone (Alto), Tenor I, II, Bassoon, and Piano. The notation includes various rhythmic values, accidentals, and dynamic markings. Handwritten annotations in boxes include 'R', 'K', 'U', and 'UK', which correspond to the row operations mentioned in the caption. Bar numbers 135, 138, 142, 147, 151, and 153 are clearly marked. The word 'matron' is written in the lower right area of the score. The handwriting is dense and detailed, typical of a composer's manuscript.

Fig. 3.15: Page from the manuscript of Dissevelt's twelve-tone composition for the Skymasters showing bars 135 to 153. R indicates the use of the original row, K the reversed row, U the inversion of the row, and UK the inversion of the reversed row.

effect in a sound, which made the ear believe that that sound “must exist.” According to Raaijmakers, adding reverberation would make any piece of electronic music acceptable: it was a false means of easing the listener’s ear and mind. He therefore began to use “cubic sounds,” i.e., sounds without an attack or decay time, which “in themselves sound unemotional and are subordinate to the construction within which they are stacked.”<sup>167</sup> Mondriaan’s idea of rejecting references to the natural world in order to emphasize pure compositional form does seem to have become part of Raaijmakers’ musical philosophy. He even considered his “development towards the visual arts and away from music as undeniably obvious now.”<sup>168</sup> As a result, he came to occupy a unique position among Dutch composers in subsequent years.

In retrospect, Raaijmakers’ rejection of the use of reverberation can be seen as a portent of his upcoming conflict with Vermeulen. After the Philips studio moved to Utrecht, Raaijmakers obtained the position of scientific member of staff, which was a considerable promotion. Vermeulen saw Raaijmakers as his eventual successor, partly because he thought Raaijmakers would guarantee the continuation of the studio’s original mission. However, with the studio placed much more centrally in Utrecht, Raaijmakers quickly became aware of other trends in

the arts in the Netherlands and realized how isolated he had been working in Eindhoven. He started listening to Badings’ music anew and then radically changed course, trying to catch up through his own compositional work and intensive collaboration with some of the composers who had worked in the Delft studio before it closed. Raaijmakers felt that a conflict with Badings and Vermeulen was becoming inevitable.<sup>169</sup>

The composers Raaijmakers was now collaborating with were Boerman, Escher and Jaap Spek. Escher and Boerman both worked on compositions at STEM in 1961 with Raaijmakers’ technical assistance, and through them, he got to know Spek. Boerman had begun work on *Alchemie 1961* in Delft in 1960, and now continued that work also at STEM in Utrecht, finishing it in November 1961. He would later describe *Alchemie 1961* as “a study of the movement of timbre.” He “wan-

Fig. 3.16: Page from an early manuscript of Escher’s “Summer Rites at Noon” for two orchestras and four tracks of electronic sounds.

ted to learn to control the 'colors' so as to allow a shape to emerge from them."<sup>170</sup> But at the same time, he had concluded that compositions that concentrated on timbre tended to be very slow, and this constant slowness did not satisfy him. According to Boerman, the use of electronic equipment had led to "a surplus of freedom in terms of sound and length," which had resulted in a "lack of constructive resistance." He felt the need for "an overall principle that could engulf the larger form as well as the shorter rhythmical structures and that could open the way towards the realization of a non-metric music."<sup>171</sup> Boerman found the answer in the application of a system based on the golden section. He began experimenting with this system in parts of *Alchemie 1961* and later applied it rigorously in works such as *De Zee* (1964–1965), *Kompositie 1972* and *Kompositie 1979*.

Escher had told Raaijmakers in 1957 that the Amsterdam city council had commissioned him to compose a piece for orchestra. The work would not necessarily have to be written for standard instrumentation and could include electronically produced material.<sup>172</sup> He started experimenting in the studio in Delft in late 1959 but did not begin work on his third symphony, *Summer Rites at Noon*, for two orchestras and four tracks of electronic sounds, until 1961. But the piece, like most of Escher's compositions of the first half of the 1960s, remained unfinished.<sup>173</sup> However, he produced some electronic parts for it at STEM between June and November 1961, with Raaijmakers' assistance.<sup>174</sup>

## **The Battle over Leadership of the Studio in Utrecht**

On the last day of his July studio sessions at STEM, Escher spoke with Des Tombe, who asked him if he would be willing to lead a possible second electronic music studio to be installed at Utrecht University.<sup>175</sup> Professor Hendrik Eduard Reeser, who had proposed before the closure of Philips' studio in Eindhoven that the new electronic music institute in Utrecht consist of a research center, an education center and a production center, wanted both studios to be part of his musicology department.<sup>176</sup> In the meantime, tension between Vermeulen and Raaijmakers was increasing,<sup>177</sup> which soon led to Vermeulen's request that the university accept his resignation as of October 1, 1961.

Although the minutes of the CEM assemblies do not note the problematic situation in Utrecht, it was Bomli, the organization's chairman, who now felt the need to intervene. He wrote a letter to Des Tombe, sending copies to Casimir and Vermeulen, in advance of a meeting scheduled for October 11, 1961. In it, he said he had asked Vermeulen "to name facts and symptoms that [could] clarify somewhat how the highly unhealthy situation between both gentlemen [Raaijmakers and Vermeulen] had come into being."<sup>178</sup> It was Bomli's understanding that Raaijmakers had taken an unacceptable stance. Raaijmakers had refused to cooperate with Vermeulen but was convinced he could not be fired. Apparently, "Mr. R. was suffering from severe overstrain, or he had behaved in a highly insubordinate manner."<sup>179</sup> Bomli regretted the fact that Vermeulen had tendered his resignation. On the other hand, he could un-

derstand it, since there appeared to have been a “breakdown of authority” at STEM.<sup>180</sup> Bomli was convinced that the problem could not be solved merely by letting Vermeulen go and allowing the man who had caused it to be victorious. Therefore, he said, Vermeulen should postpone his resignation for another year. It should formally be made clear to Raaijmakers that he was “working under the authority of Mr. Vermeulen and should act accordingly.”<sup>181</sup> If he was not willing to cooperate with Vermeulen, then logically he should leave. Des Tombe had earlier asked Bomli whether he would agree to placing STEM under the supervision of the Utrecht electronics professor J. J. Zaalberg van Zelst (1911–1978) and Escher. Bomli had agreed, but he now withdrew his approval of Escher, whom he considered “not capable of fulfilling the function of musical supervisor.”<sup>182</sup> Additionally, Escher was so dependent on Raaijmakers that Raaijmakers, not Escher, would in effect become head of STEM. According to Des Tombe, if an artistic director was needed at STEM, there was “only one man in the Netherlands musically and technically qualified for the position: Henk Badings.”<sup>183</sup>

Vermeulen went to the October 11 meeting with Casimir and Des Tombe well prepared. According to notes he wrote beforehand, he wanted to point out that appointing Escher as the musical leader of the studio would be understood both inside and outside STEM as a victory for Raaijmakers. He would have been successful in “eliminating both Badings and Vermeulen, and now able to realize his plan to gather a small group of like-minded composers around him.”<sup>184</sup> He would no longer be disturbed by other composers who wanted to carry out more or less commercial assignments or by technicians who wanted to do scientific research. Raaijmakers would then be “regarded as the actual head of the studio [...] because Escher was totally dependent on him technically and musically.”<sup>185</sup> Vermeulen also questioned Raaijmakers’ abilities. He expected that Spek, who considered himself a friend of Escher’s, would soon appear in the studio with his “students” and gradually take over the leadership so as to fulfill his “experimental, compositional and educational duty” and execute his plans for the installation of the studio and the instruction of musicians whom Raaijmakers so admired.

If Escher were appointed as musical leader, the studio would be closed to Badings, who would no longer be willing to set foot in it. Vermeulen doubted seriously whether it was acceptable to take

Badings’ achievements, the knowledge and skills he had taught Raaijmakers, to which Raaijmakers had added little to nothing, the reputation and goodwill he had gained so widely in the Netherlands and abroad, away from him just like that and hand them over to someone else.<sup>186</sup>

Vermeulen, like Bomli, considered Badings the only person qualified to lead STEM:

In my opinion, there is only one man in the Netherlands with the knowledge and abilities, the guts and the energy to do something independent in the field



of electronic music and enough willpower not merely to follow the big trends without a moment's thought. All others, Ton de Leeuw, Escher, Hans Kox, Dis-sevelt and Raaijmakers, have parasitized him, although they used different styles, and then called him names later on.<sup>187</sup>

Vermeulen had done his best to give free access to the studio to other composers besides Badings. But now that the studio was

at risk of being taken over by a relatively small group of so-called young composers, there [was] only one good and decent solution: to give Badings leadership of what he himself [had] built up from the ground, and that [had] established an excellent reputation in the world because of his efforts.<sup>188</sup>

Initially, STEM had been part of Reeser's musicology faculty, but by June 1961 it had become an independent organization with its own budget.<sup>189</sup> Though Badings did not yet have a formal position at STEM, he was appointed as an acoustics professor in the musicology faculty that year.<sup>190</sup>

By November, the new situation had become clear to Escher. He had accepted Des Tombe's proposal of July 1961 to head a possible second Utrecht studio, but only on certain conditions. These he had explained in a letter to Casimir, who was aware of Escher's previous plans for a new "Institute for Phonetic, Acoustic and Experimental Musicological Research." From Escher's point of view, Vermeulen was pushing STEM "obstinately and relentlessly" in the wrong direction: it was "a studio for electronic music under supervision of a man who for years had been striving for his own objective: a Badings supremacy in Dutch electronic music."<sup>191</sup> All this had turned STEM into a battleground. In Escher's words:

A waste of mental energy, a paralyzing effect on the urge to experiment, expand and be creative, is the inevitable result of such a battle, and for almost six months now, this waste has not only been tolerated but fueled [...] by significant incompetence with regard to [...] electronic music as a compositional discipline, as theory and practice.<sup>192</sup>

According to Escher, musical creativity and the serious search for adequate electronic-compositional structures were properly part of the domain of culture. Furthermore, artistic creativity as well as some forms of pure scientific practice had to be judged by cultural standards. Creative artists and certainly composers had never before had to defend themselves within the walls of their own studios against the reproach that they weren't engineers or physicists. But composers had only gained access to the electroacoustic studio – which was too expensive to ever become their own – by "humbly knocking at the mighty gates of technology, industry

and radio broadcasting. They were and are usually allowed in, but apparently on condition that the technicians can laugh a little at the dotty artists.”<sup>193</sup>

Escher explained in his letter to Casimir that he found this an unworthy and unhealthy attitude, which made the atmosphere in the studio in Utrecht more troubled every week. The studio had over fl. 100,000 worth of equipment, which “together makes up an impressive amount of mathematical and physical intellect.”<sup>194</sup> Any young composer who had found his way to an electronic music studio was smart enough to realize this. Escher continued:

It is stupid to doubt the artistic integrity of these young pioneers from the very start by spreading anecdotes about their supposed “antitechnical” or “antiscientific” inclination and the lie that they are “only messing around.” [...] On the contrary, they are serious workers with a strong urge to explore unknown territories. They therefore have better things to do than to kneel down and pray before a tape recorder or an Allison filter.<sup>195</sup>

When asked by the governors of Utrecht University whether he would accept the position as head of the second studio, Escher had said yes. But one of his conditions was that it be “a completely autonomous institute” that was “allowed to develop its own guidelines without interference from others.”<sup>196</sup> Collaborating with Badings was “absolutely unacceptable on artistic and moral grounds.”<sup>197</sup>

Escher reminded Casimir that in his original plan there had been plenty of room for manifold types of scientific research, and that with respect to this research, he had been thinking of “entirely different things than developing a device that could replace twenty violins by means of electroacoustics.”<sup>198</sup> For Escher, such tasks belonged more to the domain of “technical Boy Scouts”<sup>199</sup> than that of scientific researchers.

Escher personally had never felt “the need to challenge Badings’ artistic credo or even his mentality”; at the same time, he was aware of “a supremacy of that credo and that mentality rapidly approaching STEM.”<sup>200</sup> According to Escher, of the people with whom he had discussed the matter, Des Tombe was the only arts man and Casimir the only science man who had shown true understanding. Therefore, he asked “arts and science to meet soon – very soon – to discuss how a start could at least be made on a second studio.” If a decision was not made quickly, Escher would consider the battle in Utrecht lost.<sup>201</sup>

On November 27, 1961, Escher wrote to Des Tombe to discuss issues that had come up during a meeting he had had with Des Tombe, Reeser and Badings three days earlier. At that meeting, Badings had expressed demands and opinions regarding the management of the studio and electronic music that had confirmed Escher’s belief that a forced cooperation with Badings could only be a formal and very difficult one. Escher was surprised that Badings had been allowed to present a list of demands. Escher wrote Des Tombe that he had decided on the spot



to leave certain utterances by Badings unanswered, since otherwise the discussion would have turned into an argument. He therefore now found it necessary to make some additional comments. First, he said, all discriminatory acts against Raaijmakers had to stop. If not, the atmosphere that had been poisonous for five months now would not change. Along with Raaijmakers, Escher considered it necessary that the two technicians, Van Kuilenburg and Weiland, be available to help design the new studio. To the outside world, it should be made very clear that the current studio to be led by Badings and the new one to be led by Escher were two completely separate departments, with diametrically opposed artistic objectives and guidelines. Escher said he believed he had made enough concessions by now, and only if these conditions were met could he accept the position as head of the second studio.<sup>202</sup>

Vermeulen was correct in his belief that Raaijmakers was under the influence of Jaap Spek. While Raaijmakers was assisting Escher, Escher had frequently talked about Spek. Spek had built up a certain reputation while working in the studio in Delft, and although Escher considered him to know very little about music, he was impressed by his knowledge of the physical aspects of sound and his studio skills.<sup>203</sup> Peter Schat, who was assisted by Spek in the Delft studio during production of *Studie* (1959),<sup>204</sup> thought Spek had a certain genius. According to Schat, Spek had achieved a very high level of technical proficiency, and if he were to become productive, he could potentially be one of the Netherlands' most important electronic musicians.<sup>205</sup> However, Spek would only compose one electronic piece: *Impulsen* (1960).

In June 1961, Raaijmakers had visited Spek in the Dutch town of Voorburg and come to believe that Spek would play a decisive role in his life in the coming years, because they had "a common musical objective."<sup>206</sup> Spek decided to join the discussion of STEM's future by writing to Des Tombe, because he was afraid that the current situation would lead to collapse. He supported Raaijmakers but was also seeking to gain a more secure foothold at STEM himself. According to Spek, "musicological backgrounds and the existence of electronic compositions that had attained permanent positions in the contemporary musical landscape legitimate[d] the establishment of a studio." However, "the combination of high expectations and underestimation of the tasks at hand [had] led to a difficult state of affairs in both Utrecht and Delft."<sup>207</sup> Spek pointed out that in Delft, the unscientific nature of electronic music had been a decisive argument for closing down the studio (along with its intended temporary status, of course), and in Utrecht, the opening of the studio within a university framework had been defended with the promise of a scientific research program. Spek thought that at this moment, there was a need for a person who could act as a mediator between the technical and artistic domains, and though he did not mention a name, it was clear from the context that he meant Raaijmakers. Furthermore, there should be two fully equipped studios at STEM of different designs as soon as possible, one mainly for recording and editing and the other for sound transformations. Education should not extend beyond theoretical courses, coupled with practicals to explain the features of the equipment in both studios. Spek was aware that

Vermeulen had personal objections against him, but he was confident that these could be overcome. He pointed out in his letter to Des Tombe that he considered Raaijmakers his only true colleague in the field of electronic music. It would be possible for the two to come to a very fruitful collaboration, he said – a collaboration that, to a certain extent, was already there.<sup>208</sup>

By the end of October 1961, Raaijmakers was still assisting Escher in Utrecht by the grace of Vermeulen,<sup>209</sup> but as soon as work on the electronic parts for Escher's *Summer Rites at Noon* was over, he went back to Eindhoven and waited for news from Escher. There were some positive signs at first, but it soon became clear that Escher had overplayed his hand. Vermeulen had accepted Bomli's suggestion that he postpone his resignation, there would be no second studio, and Spek's proposal had no significance. Raaijmakers decided to leave STEM.

After Raaijmakers left, the Utrecht studio was used for the production of music for Jan Vrijman's (1925–1997) film *The Reality of Karel Appel*, about the eponymous painter (1921–2006). Vrijman had thought for months about what music would be suitable but had not found a solution. He wanted "equivalent music which, like [Appel's] paintings, would break through all conventional concepts."<sup>210</sup> Although Appel was not a musician, he nevertheless proposed to Vrijman that he himself make the music to accompany the wild actions of his painting on film, using electronic means.<sup>211</sup> Vrijman welcomed the idea immediately. He realized that Appel would never be able to make music according to the usual standards, but at the same time he understood that Appel "could apply his creative power and courage to produce an anti-music that would certainly fit the film better than any music by any Dutch composer."<sup>212</sup> Recordings of Appel's voice and improvised piano, timpani, drum and Hammond organ playing were made in a radio studio in Hilversum, and Frits Weiland processed the recordings, edited them and combined them with electronic sonic effects at STEM in Utrecht. The music was released on LP as *Musique barbare*.

After his experience at STEM, Raaijmakers saw Appel's appearance there as an insult. After all, Vermeulen had denied the highly educated composers Rudolf Escher, Jan Boerman and Ton Bruynèl studio access, and now he had opened the doors to someone without any musical background whatsoever.<sup>213</sup>

From STEM's list of 1962 electronic music productions, it is obvious that studio activities there had subsided to a minimum. Only two soundtracks were made: Rens Groot's music for the animated short film *De zwarte bonenluis* (The black bean aphid) and Hans Kox's music for Hattum Hoving's short film *Zeilen* (Yachting), which won the Technical Grand Prize of the Image and Sound Superior Technical Commission at the 1963 Cannes film festival. Both soundtracks were made with technical assistance from Weiland, who had become the main studio technician now that Raaijmakers had left. On October 22, 1962, Vermeulen officially resigned, and Badings was installed as the new director of STEM.<sup>214</sup> There was still no educational program.



Fig. 3.17: Front cover of "Musique barbare" by Karel Appel, which contained the tracks "Paysage électronique," "Poème barbare" and "Le cavalier blanc." *The World's Window / Philips 99954 DL, 1963.*

### **Gottfried Michael Koenig at Gaudeamus: Critical Remarks on Sound Spatialization**

Some days after the press conference on June 12, 1961, Walter Maas had written Gottfried Michael Koenig (\*1926) in Cologne to ask whether he was willing to give a series of lectures at 1961's Gaudeamus Muziekweek, scheduled to take place from September 2 to 9. The week would also feature a concert of electronic music, programmed with the help of Philips and STEM. After discussing Maas' request with Stockhausen, Koenig said yes.<sup>215</sup> Although the detailed proposal he sent to Maas was eventually accepted practically unchanged, Maas still needed the formal approval of the CEM assembly. This was requested almost a month later; CEM's members said they had no objection to Koenig giving "a lecture" on electronic music at Gaudeamus Muziekweek.<sup>216</sup>

In fact, Koenig ended up playing a much more prominent role. He directed the composers' course and gave no fewer than six lectures, including the opening speech on September 2. The lectures were titled "Die musikalische Zeit" (The musical time), "Musikalische Grafik: Musik im Raum" (Musical graphics: Music in space), "Aleatorik und serielles Komponieren" (Aleatorics and serial composition), "Harmonik und andere Parameter" (Harmony and other parameters), "Aspekte der gegenwärtigen Instrumentalmusik" (Aspects of contemporary instrumental music) and "Stand der elektronischen Musik in Deutschland" (The state of electronic music in Germany).<sup>217</sup>

So far, there had only been optimism about the benefits spatial representation would bring to music and theater. Spatial sound projection lay at the basis of Vermeulen's long-term research into ambiophonics, it had been used as a technique to enhance the rhetorics in Badings' *Kain en Abel*, and it had been one of the most prominent features of the Philips Pavilion at the Brussels World's Fair in 1958. Several works from the Philips Research Laboratories studio had been produced in four channels since then, and De Leeuw had additionally "spatialized" the sound of his wind quintet in *Antiphonie* by spacing the musicians far apart on stage. In the theater, Toneelwerkgroep Test had experimented with spatial stage designs and had tried to create a dedicated theater that would have the capacity for spatial sound projection.

In his Gaudeamus lecture "Musikalische Grafik: Musik im Raum," Koenig formulated several theoretical objections to spatial sound distribution based on his own experience as a composer and a listener. His four-channel electronic composition *Klangfiguren II* (1955–1956) had premiered on May 30, 1956, at WDR's large broadcasting studio in Cologne, along with Stockhausen's *Gesang der Jünglinge*.<sup>218</sup> Whereas for Stockhausen, this, Germany's first electronic music concert with multichannel sound reproduction, marked the beginning of a long series of compositions (some instrumental) exploring various spatial configurations of sound sources, for Koenig, it meant the opposite. He produced his next electronic work, *Essay* (1957), in mono. When asked why, Koenig explained that although in the performance of *Klangfiguren II* and *Gesang der Jünglinge* the sounds' spatial distribution had been in the foreground, this was in fact the least composed aspect of the music.<sup>219</sup> His lecture "Musikalische Grafik – Musik im Raum" addressed this topic in much more detail. According to Koenig, "undoubtedly, the modernity of a piece does not depend simply on the fact that it works with [...] spatial constellations."<sup>220</sup> When composers who wrote pieces for multiple speakers or ensembles were asked what role the "space" played in their music, he said, they usually said multiplying the number of sound sources made it easier to distinguish the musical events. Koenig doubted whether this was true:

Music is basically an indivisible event; when a tone is heard, it is true that in addition to a pitch, it contains a color and a dynamic, and it lasts for a certain amount of time. However, these aspects are not perceived separately; they are

part of an impression of a complete acoustical event. [...] It is only for the purpose of analysis that the musical process is split into separate parameters and the parameters in turn into single steps. In this respect, it can be said that the musical sound also comes from a certain *direction*, which dissolves into the overall perception.<sup>221</sup>

He went on:

When we hear a sound and aim to perceive it as clearly as possible, we turn our heads so that our ears are in the optimal position. In other words: we do not register the direction of the sound but instead change our own position in relation to it, so that it comes from a specific direction, namely the best. [...] The argument that multiple sound sources spread throughout the space make the musical structure clearer cannot therefore be true; on the contrary, the structure must become less clear to the extent that the sound comes from less favorable directions. [...] Composition is the art of formulating relationships and representing them as clearly as possible through music. Music, so to speak, is clarity as such, or it is not music at all. [...] Musical lack of clarity is amateurism.<sup>222</sup>

At the time of Koenig's *Gaudeamus* lecture, stereo phonograph records had only just become available, and radio broadcasts were still generally monophonic. To Koenig, the fact that composers were happy to have their spatial works broadcast in mono proved that they didn't take the spatial aspect of the music that seriously. Yet they would never have accepted it if broadcasting had removed the pitches or the dynamics of the music. In his lecture, Koenig addressed yet another reason why the use of multiple sound sources could be valid.

One could desire the sounds not only to come from various *directions* but also to *move* in various directions. However, this parameter has nothing to do with clarity; it is a new sensation. [...] The more the possibility of spatial composition nowadays enters the minds of composers, the greater the technical possibilities of electronic music become, and perhaps the greater the organizers' willingness to distribute instrumental ensembles in concert halls, the more composers should sharpen their resistance to space, so as not to become the victim of children's games or a fetishistic use of technology. We know almost nothing of space in music; we can explore it step by step, but we cannot just merrily compose pieces for it. Experiences so far give every reason for skepticism.<sup>223</sup>

Koenig also described a surprising result seen at electronic concerts where the audience was surrounded by speakers: "the listeners experienced being surrounded by loudspeakers as like

being besieged by machine guns.”<sup>224</sup> The listener had felt threatened in his freedom, whereas “he should be allowed to concentrate on what he wished to hear and not be placed helplessly at the mercy of events.”<sup>225</sup>

## The Bilthoven Electronic Music Course

Koenig returned to Germany after 1961 Gaudeamus Muziekweek. Apart from Vink’s technical instruction, the composers working in the Bilthoven studio were now on their own again. In April 1962, a committee consisting of CEM members Kees van Baaren; Oscar van Hemel (1892–1981), a composer and secretary of the Koninklijke Nederlandse Toonkunstenaars Vereniging (Royal Dutch musicians’ union); and Donemus director André Jurres (1912–2001) visited the CEM studio to listen to compositions and studies that had been realized there over the past year. The following day, they reported back to the assembly. Their conclusion was that the music was all rather naive and amorphous and didn’t make much sense. Jurres believed that a composer’s guidance was necessary for creating good work.<sup>226</sup>

Maas had in fact already asked Koenig if he would be willing to come to the Netherlands to teach in the studio four days a month. The next month, Koenig returned to talk with Maas, Bomli and Carel Brons (1931–1983), a composer and head of the VARA broadcasting company’s music department, about the possibility of running an electronic music composition course. Together they formulated outlines for the intended course, and Bomli commended Koenig’s qualities both personally and as a man of science.<sup>227</sup> The studio in Bilthoven was led by the technician Jaap Vink, who was responsible for its further technical development and the technical instruction of its students. However, education could not be limited to this. With Koenig’s forthcoming course, the composers would have an opportunity to discuss aesthetic problems as well as related technical ones with a professional. Koenig was chosen because he was a composer and longtime staff member of the electronic studio in Cologne with a good professional reputation.

The primary aim of the CEM course was to bring the participating composers to a point where they would be able to prepare scores, present them at the production studio in Utrecht and then realize the pieces there. The course would also be open to a wide circle of interested composers, musicians, musicologists, educators, critics and technicians desiring a general introduction to the artistic and technical questions raised by electronic music. Koenig planned to come four days every month for a year. The first day would be reserved for people who wanted a general introduction, many of whom would have traveled from far away. The remaining three days would be devoted to the training of composers who lived in the area or had moved to the Netherlands for the duration of their studies. On the days between monthly courses, the composers could work on completing Koenig’s course assignments.<sup>228</sup>

Whereas Kok’s lessons in the TH Delft studio had been purely technical, Koenig embedded technical subjects in discussions of composition theory. Furthermore, the lessons in Delft had



been aimed primarily at Dutch composers, while the course in Bilthoven had an international orientation from the start. The brochure was printed in German as well as Dutch and sent to Darmstadt, Germany, by early July so it could be seen by participants in the 1962 edition of the International Summer Course for New Music.<sup>229</sup>

Koenig's course launched with a press event on October 24, 1962; those invited included the mayor of Bilthoven, Kok, De Leeuw, Badings, the heads of the Dutch broadcasting companies, and representatives of STEM and of the Ministry of Education, Arts and Sciences.<sup>230</sup> Koenig wrote a speech of no fewer than twelve pages for the occasion. It began by describing how difficult it was for young composers to gain access to electronic music studios. Music academies offered young people classes in instrumental performance, conducting and composition, and even self-study could yield results, he explained. But electronic music study was strongly connected with practical work in a studio, and the technical expense of installing one by far exceeded an individual's financial means. As a result, the few existing studios had a monopoly. According to Koenig, Stockhausen had been conscious of this monopoly from the beginning and, being privileged enough to work in an electronic music studio, had felt a "moral obligation" to publish the results of his research in the form of articles and lectures, "so that at least theoretically, everyone could participate. Stockhausen simultaneously worked on behalf of his colleagues."<sup>231</sup>

All this was reason enough to warmly welcome the installation of the studio in Bilthoven. For Koenig, however, it had other important functions besides composition training. Electronic music not only enriched instrumental music with new sound colors and spatial effects, "it invalidate[d] the traditional division of labor between composer and interpreter; in addition, it show[ed] that the musical tone [was] not an indivisible element."<sup>232</sup>

Later in his talk, Koenig returned to the problems inherent in the spatial distribution of sounds. He explained how the creation of irregular structures of filtered impulses had led to a new type of sound constellation that could not be described in detail but only in terms of general statistical characteristics. Instead of discrete descriptions of the individual elements of a sound constellation, there was a so-called field definition. This was the source of the importance that the element of chance had obtained in music. Koenig continued by stating that along with the composition of fields, there had arisen a desire to distribute sounds in space. The availability of four-channel tape recorders and the ease with which multiple speakers could be positioned in a concert hall had made it hard to resist. Nevertheless, he said, "mutual fertilization of music and technology has not yet taken place in this area. Four channels are not enough; they stay 'punctual' and therefore obstruct the transfer of the field conception into the spatial representation." It was not possible to achieve with four or even eight channels what Koenig called "spatial concentration or dispersion, speed of movement, or spatial sound densities."<sup>233</sup>

Koenig's course in Bilthoven was a success from the start, and all 28 students were enthusiastic. Just before it started, Vink had finished building a self-designed mixing desk; he then planned to build a ring modulator.<sup>234</sup> A reverberation plate was made available by Radio

Nederland Wereldomroep, the Dutch overseas radio broadcasting organization. Most of the technical ingredients necessary for carrying out experiments in the tradition of the Cologne studio were in place, albeit in smaller numbers. Koenig's handouts of assignments for the students to work on in his absence give a clear impression of the studio's capabilities, which were rather limited even for 1962. For instance, dynamic envelopes could not be created with a tone gate<sup>235</sup> but had to be made manually: an envelope that started with a sharp attack followed by a decay was made by turning on the sound with a switch or plugging in a cable and then turning down the level with a knob.<sup>236</sup> Chopping a continuous sound into a rhythmic pattern was effected by sending the sound to a tape machine recording on a loop made up of short pieces of recordable tape alternating with pieces of leader tape, so the chopped sound would appear at the output of the tape recorder. The speed of the rhythmic pattern could be changed by varying the loop's tape speed.<sup>237</sup> The studio, located in a small garden house on the Gaudeamus property, was so tiny that in order to play a long tape loop, the door had to be opened and the loop run into the garden.<sup>238</sup>

In addition to giving monthly lectures and practical assignments, Koenig delivered analyses of sixteen electronic compositions by Stockhausen, Eimert, Ligeti, Pousseur, Franco Evangelisti and others, all of which had been realized in Cologne. Five works produced by students during the course were presented and discussed at one of the last sessions in June 1963.<sup>239</sup> The course was repeated from October 1963 to June 1964, and almost all the students registered a second time.<sup>240</sup>

## **The Utrecht Studio under Henk Badings and Rudolf Escher's Final Attempt**

On October 22, 1962, two days before Koenig began his course in Bilthoven, Henk Badings was installed as the new director of STEM in Utrecht. He had just returned from the University of Adelaide in Australia, where he had been a guest professor of music theory and composition for six months.<sup>241</sup> Just a few days after becoming director of STEM, he also accepted a professorship at the Staatliche Hochschule für Musik in Stuttgart. He said in an interview that he intended to keep his position as head of the studio – “especially since the new electronic studio was his achievement.”<sup>242</sup> When asked whether he planned to lecture elsewhere, he confirmed that, according to arrangements made previously, he would return to Australia in the summer of 1963.<sup>243</sup> During the 1962–1963 academic year, he also lectured at Point Park College in Pittsburgh.<sup>244</sup> On behalf of the board of governors of Utrecht University, Des Tombe stated that Badings could not combine the positions in Stuttgart and Utrecht and therefore needed to resign from STEM by the end of the 1962–1963 academic year.<sup>245</sup> The problem of STEM's leadership remained.

After the nadir in 1962, production of electronic music at STEM had increased again somewhat. In 1963, Badings' student Will Gay Bottje (1925–2018) composed a piece for concert

performance, and his students Trudi Ittmann and Hans Kox composed background music for plays, while Badings himself composed *Three Lucebert Songs* for male choir and electronic sounds, based on poems by the Dutch artist Lucebert (1924–1994).<sup>246</sup> Badings returned to Australia in July and stayed there for four months.

In May, ahead of Badings' announced resignation, Des Tombe told Koenig a change in leadership was about to take place and asked him to consider taking the position.<sup>247</sup> Koenig was interested and saw possibilities for connecting the production focus of the Utrecht studio with the educational program in Bilthoven, where it had become clear that the course was a success and would probably continue for another year.<sup>248</sup>

Escher had stated in July 1962 that the Utrecht affair was a closed chapter for him.<sup>249</sup> But now that it was clear that Badings' job at STEM was coming to an end, Escher decided to try again to advance his plans for starting a laboratory for experimental musicological research. In November 1963, he sent professor Hendrik Eduard Reeser a twelve-page report including a detailed description of the artistic and scientific tasks, the structure, the technical requirements, the accommodation and the staff of his proposed laboratory. According to Escher, "One should never forget that this exceptional laboratory would primarily serve a special form of artistic creativity, namely musical composition, a discipline that belongs completely to the cultural sphere."<sup>250</sup> It could even be said that the laboratory "[would serve] a special form of pure scientific research: that is, the phenomenology of music."<sup>251</sup> Escher warned that as soon as these cultural-scientific premises were lost sight of, the discussion would immediately shift in the direction of "electrical engineering, entertainment music and trade."<sup>252</sup>

Because most of the equipment used to produce sounds in electronic studios had been built as measurement devices and not musical instruments, Escher wanted the new laboratory to have a workshop where existing devices could be modified and new ones developed. For instance, the third-octave filter should be replaced by a twelfth-octave filter with an additional keyboard, so that "noise scales" could be played on it. Kok had assured Escher that it would be possible to build such a "musicalized filter."<sup>253</sup>

According to Escher, a sound laboratory that was not sufficiently acoustically insulated would make work impossible. Indeed, the lack of acoustic insulation was a big problem at STEM. The building on Plompetorengracht was shared with other users, and working in the studio was often impossible because the neighbors were either making too much noise or complaining about the noise from the studio. Escher presumably had STEM in mind when he wrote, "Abandoned schools and other dilapidated little buildings, for which the universities in our welfare state are still showing such a strong preference, are unsuitable for the housing of an electronic sound laboratory. It is usually impossible to provide them with proper sound insulation. Peace and quiet are primary requirements."<sup>254</sup> Escher concluded his proposal by stating that "a counterbalance against German supremacy in the new music theories seems very desirable to me!"<sup>255</sup>

When Badings returned from Australia in November 1963, the new academic year had started. And in spite of Reeser's December 1962 newspaper announcement, Badings was still in charge of STEM. The Australian pianist and composer Geoffrey Madge (\*1941) had met Badings while Badings was lecturing in Adelaide at the Elder Conservatorium of Music. Madge came to the Netherlands through an exchange scholarship arranged by Badings and was given access to STEM. While a student of Badings', Madge composed two electronic studies between January and March 1964. But much to Badings' dismay, Madge became more and more interested in the music of Boulez, Stockhausen and Xenakis. This finally led to a big argument, after which the relationship came to an end. However, Madge stayed in the Netherlands for the rest of his career.<sup>256</sup>

In a new development at STEM, in May 1964, Badings brought a group of musicology students who were attending his acoustics lectures at Utrecht University over to the studio for practical exercises.<sup>257</sup> He even appointed the NRU technician Theo van Woerkom to assist them. Van Woerkom had helped Badings before on several occasions, including production of *Orestes* (1954), and he had now left his position at the NRU to come to STEM. Technician Frits Weiland, much to his surprise, found Van Woerkom sitting at Weiland's desk overnight.<sup>258</sup> Badings had appointed Van Woerkom without consulting anyone at STEM beforehand. Van Woerkom also assisted Badings with production of his final compositions at STEM.

During his stay at Point Park College in Pittsburgh, Badings had heard the American Wind Symphony Orchestra with conductor Robert Austin Boudreau (\*1927). The experience inspired him to compose *Pittsburgh Concerto* for wind instruments and electronic sounds on tape in the summer of 1964.<sup>259</sup> Around the same time, he finished *Toccata I* and *Toccata II*, both for tape alone. When Badings was finally forced to resign as of September 1 that year, Van Woerkom left STEM with him.<sup>260</sup>

### **Tom Dissevelt's *Fantasy in Orbit***

By far the most exceptional work produced at STEM during the years under Badings was Tom Dissevelt's *Checkpoints*. The work was commissioned by Philips' Phonographic Industries and released on long-playing record in 1964 as *Fantasy in Orbit*. Between July 1963 and May 1964, Dissevelt composed fourteen pieces of around three minutes each, which together portrayed a journey around the world. The individual tracks had titles such as "Caribbean," "Atlantic," "Africa," "Indian Ocean" and "Bali." It was only after the music was produced that Philips decided to change the theme to space travel for commercial reasons. Escher had obviously been right in June 1960 when he had written that interest in electronic music production from companies like Philips had to do with "space travel romanticism."<sup>261</sup> According to the sleeve, the record's theme was as follows:

Our days are the days of space flight – and of electronics (which play, by the way, a tremendous role in astronautics). The composer, a child of our times, has the natural wish, inevitably, to be contemporary – so he has chosen the electronic language to write his music in. The message in this music is, therefore, simply this; that man in orbit never loses contact with the Earth, not for a single moment. At lift-off and over the deep waters of the oceans, over barely accessible jungles and forests, over cities of which he can see only a dim glow, over the heads of millions and millions of fellow creatures – men as well as animals – he feels that the Earth is permanently calling him. The color of those feelings may differ from time-zone to time-zone, from continent to continent, from coast to coast. Each region exerts its own pull. But every vibration of it ties him to the Earth below.<sup>262</sup>

Dissevelt was among the 28 students who had taken Koenig's course in Bilthoven in 1962–1963, and its influence on *Fantasy in Orbit* is clear. As previously stated, comparison of the four works of Dissevelt's *Electronic Movements*, made in 1958 and 1959 with Kid Baltan at Philips Research Laboratories, shows that harmonically and rhythmically, the fourth piece, "Vibration," was much more complex than the others (see Chapter 3, 80–3). Sketches indicate the use of a row and its inversion as the basis for the melodic material and the chords. It has also been previously mentioned that the jazz orchestra recordings that appear in 1961's *Intersection* are based on a twelve-tone composition Dissevelt wrote for the Skymasters (see Chapter 10, 209–13). A pitch organization with a certain connection to dodecaphony also plays a role in *Fantasy in Orbit*, but here, tone rows hardly appear in the form of melodic constructions. Instead, they are used at smaller time scales to create various kinds of sequential

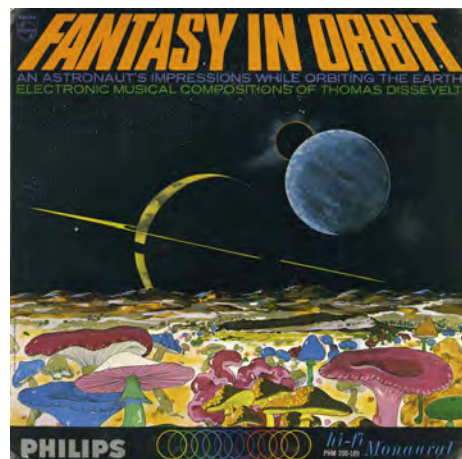

Fig. 3.18 and 3.19: European (left) and US record covers of Tom Dissevelt's "Fantasy in Orbit."



The manuscript page is divided into several sections:

- Top Section:** Contains pitch series and frequency data. The first line shows notes  $12$  (C),  $11$  (F), and  $10$  (B) with frequencies  $131 \text{ Hz}$ ,  $174.6 \text{ Hz}$ , and  $247 \text{ Hz}$  respectively. The second line shows notes  $6$  (F),  $12$  (F#), and  $6$  with frequencies  $349.2$ ,  $262.6$ , and  $195$ .
- Middle Section:** Features a series of notes with stems and various annotations. A circled label "Group 4" is present. Below this, there are four groups of notes labeled "Group 4", "Group 3", "Group 2", and "Group 1".
- Bottom Section:** Contains a graphic representation of the superposition of various layers of tone groups. It shows a series of notes with stems, some marked with "x" and "v". A circled label "Group C" is present. Below this, there are two groups of notes labeled "Group 8" and "Group 9".

Fig. 3.20: Manuscript page of Tom Dissevelt's "Fantasy in Orbit." The pitch series in 3–20 appears in a permutation, with a graphic representation of the superposition of various layers of tone groups.



tone and noise clusters and fast, repetitive patterns. Rhythmic complexity is then achieved by superimposing the looped sequences and patterns in such a way that their relationships gradually shift over time.

Creating complexity by layering different periodic structures is actually a compositional technique that is present as well in works by Koenig, such as his *String Quartet 1959*, and it also played an important role in his 1962 electronic composition *Terminus*. *Terminus* was analyzed extensively in the Bilthoven course in January 1963,<sup>263</sup> and Dissevelt was presumably influenced by these ideas.

Although aesthetically Dissevelt's music is not similar to Koenig's at all, in general one can see the influence of serial composition techniques and the related concept of permutation in many of his manuscripts for *Fantasy in Orbit*. Not only pitches are often organized in series; so are durations. It is Dissevelt's mixture of popular music roots with an almost obsessive interest in dodecaphonic and avant-garde serial composition techniques that makes *Fantasy in Orbit* a unique document. But it was also Dissevelt's tragedy. His music fell entirely between categories. The "serious" composers of his time ignored his work because of its background in popular culture, while at the same time, the popular audience did not understand his artistic intentions. *Fantasy in Orbit* was not a success,<sup>264</sup> and it was to be Dissevelt's last encounter with electronic music. Its release also marked the end of Philips' involvement in electronic music production in the Netherlands.



## Chapter 11

### Private Projects

#### The Mood Engineering Society

Soon after Raaijmakers left STEM, he became involved in the Mood Engineering Society (MES), which was founded on December 3, 1961, by people including the artist Willem de Ridder (\*1939), Misha Mengelberg, Peter Schat and Jaap Spek.<sup>265</sup> The MES intended to “remove the existing boundaries between music, theater and the visual arts by means of multimedia projects and concerts.”<sup>266</sup> In January 1962, De Ridder and Schat wrote an open letter asking the local governments of several cities “to take into account twentieth-century developments in music and drama when building future theaters.”<sup>267</sup> Escher had been asked to sign too, but he deemed the initiative “complete nonsense.”<sup>268</sup> De Ridder and Schat had concluded that “the shoebox diorama format in which drama [was] still presented [had] not changed since the Renaissance.”<sup>269</sup> The MES therefore proposed the building of

a space in which the fixed elements, such as the stage, seats, balconies and orchestra pit, would all be replaced by mobile installations. The acoustics should be variable. It should be possible to adjust the theater to the requirements of the artwork, rather than the opposite, as is usual. The MES desires the development of “auto-theater”: a form of drama in which the audience itself will take part in the action. It will break with unidirectionality and replace this with interaction, so that the audience will be released from its indifference. Silence will also be an important element of this new form of theater. During silence, the members of the audience will become restless, until they experience that through their behavior they are a part of the artwork.<sup>270</sup>

The MES planned to organize several events that would include electronic music, and it therefore asked CEM to make the necessary equipment available free of charge. At the next CEM assembly, Vermeulen stated that the equipment at STEM was in use on a daily basis, so it was not available for concerts. Maas was more generous; for the MES’ upcoming concert in Utrecht he had already granted the use of Gaudeamus’ Telefunken M23 tape recorder and possibly also the two NRU loudspeaker columns. There was concern in CEM, however, about whether the MES was legitimate enough to merit help. CEM chairman Bomli argued that the MES consisted of “a small group of persons who had met by chance.”<sup>271</sup> CEM as an organization could not lend its equipment to the private individuals of the MES. It was decided that “CEM’s secretary would reply to the MES that discussion at the assembly on February 9, 1962, had not led to the prospect of collaboration.”<sup>272</sup>

The first event organized by the MES was a concert/performance at the theater De Lantaren (The lantern) in Rotterdam on February 1, 1962. It was accompanied by a documentary exhibition of scores, photos, drawings, scale models and other works in the foyer.<sup>273</sup> There was a great deal of interest, and to stress the event's importance, the group preceded it with a press conference, at which it further explained its desire for local governments to build a new type of theater.<sup>274</sup> The concert program consisted of instrumental works by Mengelberg (*Exercise* for flute), Rob du Bois (1934–2013) (*Movements* for piccolo flute and piano) and Louis Andriessen (*Paintings* for flute and piano), theatrical pieces by De Ridder (*Monochroom* for piano and actor and *Fourteen Actions* for two actors) and Schat (*Sextet* for violin, prepared piano, flute, tom-tom and three actors) and electronic compositions on tape by Dick Raaijmakers (*Pianoforte*), Jan Boerman (*Alchemie 1961*), Ton Bruynèl (*Reflexen*) and Jaap Spek (*Impulsen*). Peter Schat's composition introduced spatiality through prescribed routes on stage for the performers.<sup>275</sup> The concert was repeated two weeks later in the Blauwe Zaal (Blue hall) of the Stadsschouwburg (City theater) in Utrecht. By then, it had become clear that De Ridder's ideas and those of the composers were quite far apart. His works could be categorized as conceptual art, while most of the composers had written conventional musical compositions. Schat found the events so embarrassing that after the second one he returned to Basel, where he had begun studying with Boulez in 1960.<sup>276</sup> Four days after the Utrecht event, the third MES concert took place in The Hague, without Schat's *Sextet*. A fourth concert was planned for March 2 in Amsterdam, but it was canceled, because the group had by then fallen apart.<sup>277</sup> In retrospect, the MES is often regarded as a precursor of the Dutch Fluxus movement branch, in which both De Ridder and Mengelberg would be active for some time.<sup>278</sup> By April 1963, Spek was planning to move to Cologne to become Stockhausen's assistant. It was a big step in his career, and he needed a recommendation letter from Kok. Spek stated proudly: "[E]verything I have learned and worked out that enables me to accept this important assignment has its origins exclusively in [my experiences in] Delft."<sup>279</sup> Spek stayed in Cologne for four years and then left for the United States.<sup>280</sup> As soon as he arrived in New York, he visited Dick Higgins (1938–1998), one of the founders of the Fluxus movement, to whom he commended Raaijmakers as "the only original music thinker in the Netherlands."<sup>281</sup>

### **The First Private Studios and Their Early Productions: Jan Boerman, Ton Bruynèl, Dick Raaijmakers**

When Raaijmakers left STEM at the end of 1961, he had no access to an electronic music studio for the first time since 1957. On the other hand, in his years at Philips and STEM, it had always been difficult for him to find time to work on his own compositional projects. Available studio time was limited, and there was always other work to do. Now the situation was the opposite: he had all the time he wanted to think and compose but no studio to use.

After the studio in Delft closed, Jan Boerman was occasionally allowed to work in the one in Utrecht, where he was assisted by Raaijmakers. There, they had completed *Alchemie 1961*, a work Boerman had started composing in Delft in 1960. Work on *Alchemie 1961* had just ended when Raaijmakers left STEM. Boerman soon followed suit; in February 1962, he went to the studio to collect his tapes, not intending to work there again.<sup>282</sup>

Throughout 1962, Raaijmakers and Boerman waited for things to take a turn in a direction that could be beneficial for them. Meanwhile, Raaijmakers supported Escher's plans for a laboratory for experimental musicological research, and together they tried to convince the University of Amsterdam of its importance.<sup>283</sup> By October 1962, Raaijmakers was hopeful that this studio would indeed come into being. He had heard from Marleen Habraken-van Hall that her father, the mayor of Amsterdam, had received a positive report on the subject. Professor Hendrik Mol and his phonetic sciences department were about to move to a new building, and there might be room for a new studio there.<sup>284</sup>

Access to the CEM studio was not a possibility for Raaijmakers and Boerman, and both men had made a firm decision not to take Koenig's course in Bilthoven. In a letter to Escher, Raaijmakers described it as "the German invasion, alongside Badings' position in Utrecht."<sup>285</sup> Towards the end of 1962, Raaijmakers became desperate and seriously considered a radical change in profession.<sup>286</sup>

Although Raaijmakers' relationship with Roelof Vermeulen had been damaged, he was still in contact with Hendrik Casimir at Philips Research. On January 26, 1963, Casimir went to New York, where he visited Vladimir Ussachevsky at the Columbia-Princeton Electronic Music Center. After Vermeulen's attempt in March 1959 (see Chapter 3, 77–80), now it was Casimir who wanted to discuss Raaijmakers' situation with Ussachevsky and see if there were any job opportunities for him in the New York studio. But in February, on Casimir's return to the Netherlands, Raaijmakers let him know he didn't like the idea of moving to New York.<sup>287</sup>

Around that time, Boerman and Raaijmakers got the idea of forgetting about large-scale projects at institutions such as universities and founding a private studio instead.<sup>288</sup> Considering the costs of even the smallest technical setup that could be used to produce electronic music, the plan was ambitious. On the other hand, their colleague Ton Bruynèl (1934–1998) had shown that it was not impossible. In fact, Bruynèl had been working in his own private studio in Utrecht for several years. Technically, it was very limited compared with the facilities in Eindhoven, Delft, Utrecht or even Bilthoven, but of course, it had one huge advantage: it was permanently available to him and gave him total artistic freedom.

Bruynèl had studied piano with the composer Wolfgang Wijdeveld (1910–1985) at the Utrechts Conservatorium from 1952 to 1956 but had never intended to become a performing musician. According to Wijdeveld, "he only used the piano to understand the composers he loved, of whom Bach was the most important."<sup>289</sup> Bruynèl took additional lessons in counterpoint and composition from Badings. As a student at the Utrechts Conservatorium, he had some contact with Van Baaren<sup>290</sup> too, but he felt no affinity with the twelve-tone technique Van Baaren was teaching.<sup>291</sup>

In March 1956, Bruynèl debuted at a university concert in Utrecht with a ballet suite for piano; the song *Afscheid* (Farewell), with words by the poet Hendrik Marsman (1899–1940); *Nocturne grave* for flute, piano and *vocalise*; and the scherzo from a trio for oboe, clarinet and bassoon.<sup>292</sup> Although these were all instrumental compositions, in his spoken introduction, Bruynèl mentioned the possibility of using electronic music, “whereby a special sonic effect could serve as the underlying idea, as a kind of nucleus.”<sup>293</sup> After the concert, Bruynèl was praised for his talent as both a pianist and a composer, but he decided soon after to dedicate himself exclusively to electronic music. He bought a primitive Handy Sound tape recorder by the Dutch manufacturer Amroh and started to experiment with recorded piano sounds.<sup>294</sup> His experiments resulted in *Studie*



Fig. 3.22: Ton Bruynèl in his private studio in Utrecht in 1960.

(1959) for piano and tape; it and Badings' *Capriccio* for violin and tape were the first Dutch works composed for the combination of a live instrument and taped electronic sounds.

Bruynèl's first studio was located on Schalkwijkstraat in Utrecht, where several local artists had taken over crumbling houses to use as studios.<sup>295</sup> They were not allowed to live in them, however, since the houses had been condemned. Besides Bruynèl, there were graphic designers from the company De Luis (The aphid), of which the surrealist painter Joop Moesman (1909–1988) was a prominent member, and several members of *Kunstliefde* (Love for art), one of the oldest artists' societies in the Netherlands.<sup>296</sup> Although it is often said that Bruynèl had a private electronic music studio from 1957, it is more accurate to say that he had an artist's studio that gradually transformed into an electronic music studio.

Raaijmakers met Bruynèl for the first time in February 1961, when Bruynèl visited STEM. Bruynèl played his *Studie* for piano and tape, and in return, Raaijmakers played his *Pianoforte*. They appreciated each other's work and decided to meet again.<sup>297</sup> Between May and August 1961, Bruynèl regularly worked with Raaijmakers at STEM to complete *Reflexes*, a work for tape alone that consists of processed sounds from a Burmese drum; it premiered in February 1962 at the events of the short-lived Mood Engineering Society.

According to Bruynèl, the MES was an unstable affair and collapsed because of a lack of professionalism. But nevertheless, the experience was a milestone and a point of departure for him.<sup>298</sup> Bruynèl enjoyed working with artists from other disciplines – painters, dancers, writers. He made a second version of *Reflexes* for the Columbian dancer and choreographer Eleo Pomare (1937–2008), who at the time resided in Amsterdam with his dance company from New York. That collaboration resulted in a more ambitious project, *Resonance I* (1962), which, besides Pomare, also involved the sculptor Shinkichi Tajiri (1923–2009) and the painter

Sam Middleton (1927–2015). To a certain extent, *Resonance I* was based on Bruynèl's experience with the MES, and through Spek, he was allowed to work on it in the studio in Delft.<sup>299</sup> He advertised the work as a new type of music theater that included improvisation. Tajiri's metallic sculptures were amplified electronically, so that when the dancers touched them, their resonance became part of the music.<sup>300</sup>

*Resonance I* premiered on November 14, 1962, at De Lantaren, the same theater where the MES had staged its first performance. There was a large turnout of devotees of the visual arts, ballet and music. A newspaper review described the event as follows:

After the intermission, he [Pomare] improvised on the music of the Utrecht composer Ton Bruynèl, which sounds like an amplified intestinal disorder. During the pieces *Vier A.M.* and *Impro*, his movements consisted mainly of primary reactions to the sound. Dancing in this way could make the tension in a shelter during an air raid more bearable. [...] The arbitrary knocking and scraping on [Tajiri's] metal sculpture soon became annoying. The sculptures and the backdrop [by Middleton] did not make any real contribution to the spectacle, which was already unreal. [...] *Resonance* did not resonate.<sup>301</sup>

Bruynèl's multidisciplinary work was given a second performance in Amsterdam at the brand-new experimental theater of Kees van Iersel's Toneelgroep Studio (see Chapter 9, 192–97).<sup>302</sup> In retrospect, one must judge the quality of *Resonance I* by the taped electronic music, the only surviving document. When one listens to that music now, it sounds strikingly fresh and original. Whereas Bruynèl's works are usually associated more with the ideas of *musique concrète* and less with the pure electronic aesthetics of Cologne, in fact, *Resonance I*, with its sonic world dominated by filtered noises and impulses, seems to reflect on Stockhausen's work much more than on Schaeffer's. There is a certain resemblance to Boerman's *Alchemie 1961* and Spek's *Impulsen*, which might be the result of Spek's involvement in the production and of the equipment at the Delft studio. At the same time, the structure of *Resonance I* appears to be the result of a somewhat improvised working method rather than a preconceived formal design. This seems only logical given that improvisation was announced as an important aspect of the project as a whole.<sup>303</sup>

For his next work, *Collage Resonance II* (1963), Bruynèl collaborated with the poet Gerrit Kouwenaar (1923–2014). They intended to integrate sound and text through the use of electronics. Instead of writing the words first and then using a recording of them as a basis for the electronic music (a more or less common method), Bruynèl and Kouwenaar decided to let text and music grow simultaneously: "In this collage, poetry and music have literally emerged from each other, even at points where the text and the music remained autonomous and unmixed."<sup>304</sup> *Collage Resonance II* was commissioned by the NCRV broadcasting company and was performed several times a day at Amsterdam's Stedelijk Museum in March and April 1964.<sup>305</sup>



While the use of voice recordings in an electronic composition was not unusual, Bruynèl had quite specific ideas about it. He regarded spoken word recordings as building materials, with the emphasis on “building.” Bruynèl said: “To distort, to destroy, voices is fundamentally wrong to me. It is unfair.” Although he had a great deal of respect for Henk Badings’ instrumental music, he criticized him for the way he had transformed vocal material in works such as the radiophonic opera *Orestes*: “It shows a lack of respect for the identity of the performers.”<sup>306</sup>

Another aspect of electronic music that Bruynèl gradually came to disapprove of was the absence of musicians in concerts of fixed media pieces. Even his first work was composed for piano and tape, and the combination of instruments with recorded sounds was the genre he would concentrate on more and more.

When it became clear in 1963 that the University of Amsterdam would not install a studio and that they could not work at STEM under Badings, Raaijmakers and Boerman decided to follow Bruynèl’s example and found a private studio of their own. Their first studio was located at Daendelsstraat 80 in The Hague’s Bezuidenhout neighborhood, which had been a beautiful area but had suffered severely in bombing during the last months of World War II.<sup>307</sup> By 1963, many of its streets were earmarked for demolition. The building housing the studio belonged to the Haagsche Piano Academie, founded by the pianist Dorothea Cordess (1893–1946) in 1919. After her unexpected death, her nephew Frits Cordess (1925–2018), who had lived with his aunt at Daendelsstraat 80 since 1942, had become the manager of the piano academy, which at the time had around hundred students. Lessons were now given by Rudie Feenstra, who had just graduated from the Royal Conservatoire.<sup>308</sup> When Feenstra moved to Amsterdam in 1954, he proposed that Cordess hire Jan Boerman as his successor.<sup>309</sup> Boerman was already giving piano lessons on a daily basis at the school and lived in the building. Three years later, Cordess stepped down as well, and Boerman became the director of the Haagsche Piano Academie. When Cordess left the house at Daendelsstraat 80 in 1962, the building had been compulsorily purchased by the council and was no longer subject to rent charges.<sup>310</sup>

Raaijmakers and Boerman installed their first private studio in the attic at Daendelsstraat 80 in March 1963. Willem Kok at TH Delft spontaneously offered help by lending them equipment from the college’s dismantled studio, including a Peekel / Bruel & Kjaer third-octave fil-



*Fig. 3.23: Premises of the Haagsche Piano Academie at Daendelsstraat 80, The Hague, in August 1956. Boerman and Raaijmakers’ first studio was installed in the attic in March 1963. This part of the street was demolished in late 1963. Photo by Dienst voor de Stadsontwikkeling Den Haag.*

ter, a Peekel function generator and a patch field. TH Delft's technician W. Verschoor built a ten-fader mixing desk and variable speed unit for one of the tape recorders. Other equipment included an electric monochord, three Revox and two small Philips tape recorders, and a spring reverb.<sup>311</sup>

Demolition contractors appeared at the building by August 1963. Boerman had moved by then to a house across the street,<sup>312</sup> and Boerman and Raaijmakers were offered space for their studio in another building nominated for demolition at Zuilingstraat 25, near the center of The Hague. Raaijmakers moved there along with the studio, and although it too was meant as a temporary solution, he would stay there for the next twenty years.

Raaijmakers' relationship with Vermeulen had become very problematic after he had left STEM towards the end of 1961. Nevertheless, he was still receiving commissions from Philips to compose electronic music for films. Lacking a studio to work in, he passed on two to Bruynèl: *Diode III* and *Diode IV* (1962). In 1963, Bruynèl made the music for *De televisiebeeldbuis* (The television cathode ray tube) at his studio with Raaijmakers. This work was an important source of income for Raaijmakers, and as soon as the studio on Zuilingstraat was operational, he continued producing film music there, although he gradually developed an aversion to it. Between September 1963 and February 1964 he produced four film soundtracks, and as a result, he again had no time to compose his own works.

The first music Boerman produced after their studio moved to its new location was meant for a play. In the summer of 1963, Van Iersel's Toneelgroep Studio had performed Bert Schierbeek's play *Een groot dood dier* (A large dead animal) at the Holland Festival, with electronic music by Boerman and Raaijmakers. Now, Van Iersel commissioned Boerman to compose music for Studio's performance of *The Empire Builders* by Boris Vian, which premiered in May 1964. Boerman was not convinced of the play's quality but accepted the commission because he needed the money.<sup>313</sup>



Fig. 3.24: Jan Boerman and Dick Raaijmakers in their second private studio at Zuilingstraat 25, The Hague, September 22, 1963. Photo by Jaap Spek.

The two men's financial difficulties were lessened considerably in early 1964 when Hendrik Casimir made a fl. 6,000 donation to their studio.<sup>314</sup> After finishing production of the film music to which he had committed himself, Raaijmakers was able to fully concentrate for the next two years on composing a series of experimental works and formulating a connected theory that concerned fundamental questions about electronic sound, the use of loudspeakers, and related spatial aspects. He continuously discussed his ideas – which to some extent were influenced by Stockhausen – in correspondence with Jaap Spek in Cologne.

Raaijmakers had been deeply impressed by Stockhausen in November 1957 when he assisted him with the performance of *Gesang der Jünglinge* at the Philips Schouwburg (see Chapter 8, 180–85), and his admiration for Stockhausen’s music and ideas had increased over the years. When Spek became Stockhausen’s assistant in Cologne in August 1963, his first assignment was to work on the realization score of Stockhausen’s *Kontakte* (1959–1960).<sup>315</sup> In a letter to Raaijmakers, Spek reported enthusiastically that although Stockhausen was highly demanding, the work wasn’t exhausting at all. On the contrary, it had inspired him to take a critical stance towards music – an act that, according to Spek, had been abolished in the Netherlands – and would probably lead him to a better understanding of the next steps necessary for the further development of electronic music.<sup>316</sup> A few weeks later, Spek visited Boerman and Raaijmakers in their studio and brought a tape with sounds from the production of *Kontakte*, which illustrated Stockhausen’s working method step by step.<sup>317</sup> Raaijmakers was overwhelmed. According to him, nothing was arbitrary here: Stockhausen knew exactly what he wanted, and everything was coherent. “With him, every breath and every step immediately evokes meaning. His whole life is a continuous musical act.”<sup>318</sup>

In February 1964, Boerman and Raaijmakers visited Spek in Cologne, where he showed them around the WDR building. Raaijmakers was impressed by the austerity of the studio where Stockhausen had produced *Gesang der Jünglinge* and *Kontakte*. He saw Stockhausen’s notes, scores, tapes and tables of numerical data and was flabbergasted once again. According to Raaijmakers, Stockhausen’s concentration and understanding formed solid fundamentals on which his followers could continue to build for the next fifty years. It wasn’t that Stockhausen couldn’t make mistakes or hadn’t already; what made him so important for Raaijmakers was the visibility with which he executed his work as an example for others. (This observation brings to mind Koenig’s remark that Stockhausen had felt a “moral obligation” to publish his findings in articles and lectures, “so that at least theoretically, everyone could participate. Stockhausen simultaneously worked on behalf of his colleagues” (see Chapter 10, 222–24).) At the same time, Raaijmakers was disappointed by the fact that the new studio being built at the time of their visit only consolidated what had been done before: the same equipment used in the old one was being installed again, only in larger quantities.<sup>319</sup>



Fig. 3.25: Boerman and Raaijmakers’ studio at Zuilingstraat 25, September 22, 1963. From left: Peekel TF273 third-octave filter built around Bruel & Kjaer 1610, tone gate, Peekel function generator and Peekel TF823 multi-octave filter, all from the former TH Delft studio; spring reverb, three Revox F/G 36 tape recorders, mixing desk built by W. Verschoor of TH Delft, and Philips oscilloscope. Above the filters is the electric monochord; underneath them is a speaker cabinet with two Philips 9710M loudspeakers. Photo by Jaap Spek.

Raaijmakers never had direct contact with Stockhausen during these years, but he stayed well informed about his work through corresponding with Spek in Cologne and reading Stockhausen's writings. In particular, the article "... wie die Zeit vergeht ..." (How time passes)<sup>320</sup> and the electronic composition *Kontakte* had an increasing influence on Raaijmakers' own ideas. Like Stockhausen, he conceived of a time continuum in which either pitches or noises emerged from the manner and rate at which small sonic events were repeated. For Raaijmakers, however, these ideas related directly to loudspeakers and the spatial reproduction of sound. Although he was unaware of it himself, his experiences in Vermeulen's acoustics department at Philips Research Laboratories, particularly with ambiophonics, were also showing through. The crux of the ideas Raaijmakers developed around that time was that

when composed electronic sounds are played on tape through loudspeakers, it is absolutely impossible to exclude various false and irrelevant associations with "real" sounds, i.e., sounds caused by events in the physical world. [...] Another incorrect use [of electroacoustic media] occurs when the sounds become *tones* of a music that appears to be *performed* [emphasis added]. But by whom, and when? This can lie deeply hidden in even the best compositions. With most electronic works, all kinds of things are therefore already "built in," even a quasi-spatiality, as if microphones have recorded something that never happened.<sup>321</sup>

Instead of just seeing loudspeakers as reproducers of sound sources, Raaijmakers proposed understanding the sound coming from a speaker as itself a source, that is, as the cause of a whole new series of more or less related sounds. He illustrated this idea with a comparison to an airplane, which does the same thing in a spectacular way: "Flying far away, it generates sounds that continually change and differ yet come from the same unchanging source, the jet turbines."<sup>322</sup> Raaijmakers found it important "to compose in such a way that the definitive sound – the sample sound – is changeable in such a way, once it has left the loudspeaker [...], that a new series of sounds has occurred, caused by the single sample sound."<sup>323</sup> He called these series "states of morphity of the original sound."<sup>324</sup> In this context, Raaijmakers distinguished strictly between "to-the-speaker sounds" (such as composers had always produced thus far when making electronic compositions on tape) and the makeup of the actual changes that sounds undergo after they are emitted from the loudspeaker: "from-the-speaker sounds." According to Raaijmakers,

A sound travels not just one path but millions. Think of a clock in a tall tower and then of all the houses and fields around it. Even between the sound source and the ear, a thousand paths are imaginable. [...] A loudspeaker, however, can allow us to hear sounds that appear extremely "direct" at one moment (as if we are hearing something very close by: just one path between source and ear,

for example!) and then far away the next, as if the sound has blown away and is hardly definable. [...] There are innumerable ways (in “nature,” too) in which sound adds up with itself. A sound therefore is always different and always possesses an altered form. This alteration can be taken far enough that new sounds arise, with new forms and colors. We call this summation or addition auto-synchronization.<sup>325</sup>

It is essential for the technique Raaijmakers developed that each of the sound’s summations has a specific entry delay. To show how great the temporal shifts between the repeated sounds in the series had to be, Raaijmakers needed a table, a series of numbers, which he called the “phase regulator.” So far, he was only able to implement very simple shifts using tape recorders: shifts that resembled echo and reverberation. However, according to Raaijmakers, the extremely complicated shifts he was aiming for would only become possible in the future, with the use of computers.<sup>326</sup>

Since the “morphity of sound” focused on the makeup of sound as propagated in space, it was essentially a spatial concept.

The subject of morphity is the change that sound undergoes as it moves through space. The science of these changes is called acoustics, and it has noth-



*Fig. 3.26: The Salle des Illusions at the 1900 Paris World's Fair. It featured electrical illuminations and various systems of suspension for mirrors and lights that created spectacular lighting effects.*

ing to do with music. These changes must first be elevated to a musical level and connected to essential musical quantities before morphity itself can be composed.<sup>327</sup>

Raaijmakers had already rejected the use of artificial reverberation in 1961 (see Chapter 10, 209–13), because adding reverberation made any piece of electronic music acceptable: it was a false means of easing the ear and mind of the listener.<sup>328</sup> In September 1963, he explained to Spek that artificial reverberation did not change the “meaning” of a sound but that the virtual space intruded in the real space where the listener was. It resulted in “phantom theater, Salle des Illusions<sup>329</sup> [a hall of illusions] and cinema.” And much to his dislike, it was exactly this aspect of sound that composers such as Escher considered to be part of an area needing further exploration.<sup>330</sup>

Although Raaijmakers had thought of using large arrays of loudspeakers to carry out experiments in the morphity of sound,<sup>331</sup> his plans for these experiments were so technically complex that they remained unrealized. For the time being, he resorted to using tape recorders to merge all the paths that his sounds ideally should have taken in space. In a way, this was a contradiction, since in doing so, he stepped back into the domain of “to-the-speaker sounds.” In his first experiment, Raaijmakers used a loop of Herbert Eimert’s voice saying “diese Teiltöne” (these partial tones), and summed it up 32 times with the entry points spaced as regularly as possible, within a one second time span. While ideally the 32 repetitions should have been reproduced through 32 loudspeakers at different points in a space, here they were combined in mono on magnetic tape. Raaijmakers concluded that he had ended up with “complete vertical morphity”: an absolutely smooth and continuous sound. In a second experiment, he repeated the procedure, this time using a much longer piece of recorded speech.

His third experiment was based on short percussive sounds that together formed a pitch series with long rests in between the single tones. The series of sounds was repeated 64 times with the entry points of the repeated series placed within a timespan of 1 second. The recorded result was then again layered four times with entry points of 0, 1, 2 and 3 seconds respectively. Each original sound from the series resulted in a different compound sound that had “phases of movement” of more than 3 seconds.<sup>332</sup>

Based on these experiments, Raaijmakers gradually came to the conclusion that to make the morphity of the sounds the true subject of composition, he needed to reduce his starting material to an absolute minimum: an extremely short electronic impulse. In June 1964, he completed a design entirely based on impulses and their repetition structures, which led to a composition called *Canon 1: super augere*. He chose the title because canons are essentially pieces of music in which themes are repeated and layered according to rules regarding their overlap and transposition. In the case of Raaijmakers’ *Canon 1*, the theme was reduced to an electronic impulse. This reduction allowed the repetition structures or “time translations” to reveal themselves in an optimal way. To gain precise control over the necessary delay times,



Raaijmakers designed a modified tape recorder with two recording and two playback heads, which was built by W. Verschoor, a technician at TH Delft. The relative distance between each recording and playback head combination determined the spacing of the impulses. If the spac-

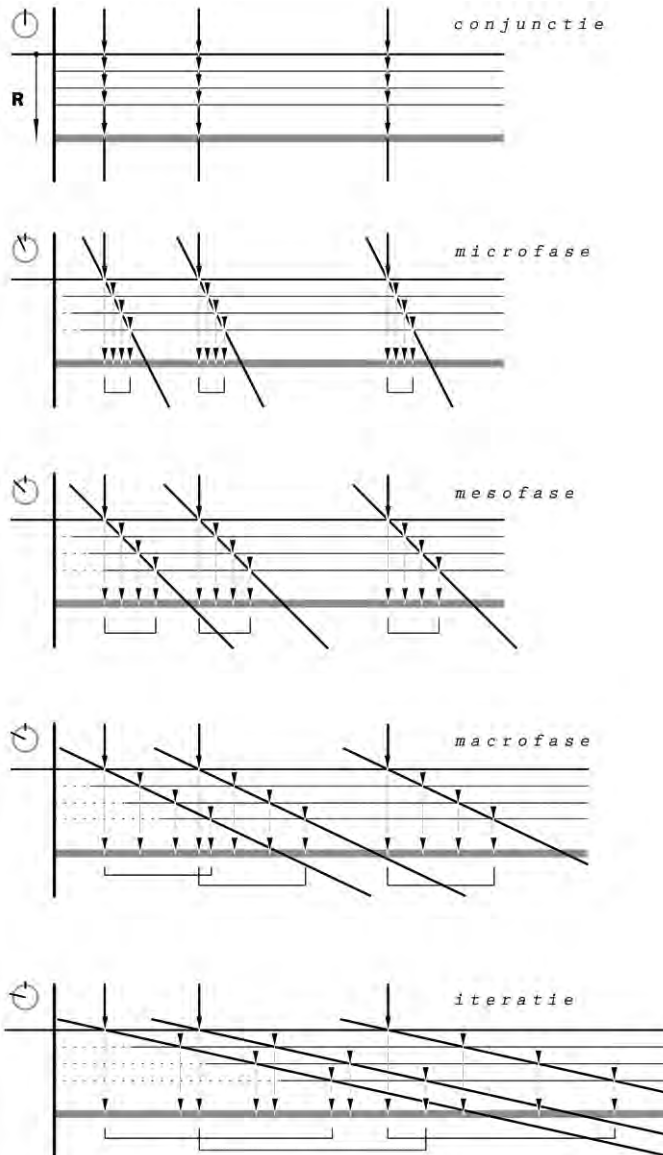

Fig. 3.27: Different categories of translation as used in Raaijmakers' "Canon 1": conjunction, microphase, mesophase, macrophase and iteration. From "Cahier "M": A Brief Morphology of Electric Sound," 95; illustration by Hans van Mourik.

ing was very close, the repeated pulse resulted in a so-called double impulse, which sounded pitch-like. With wider spacings, the repeated impulse became audible as a discrete event in time.

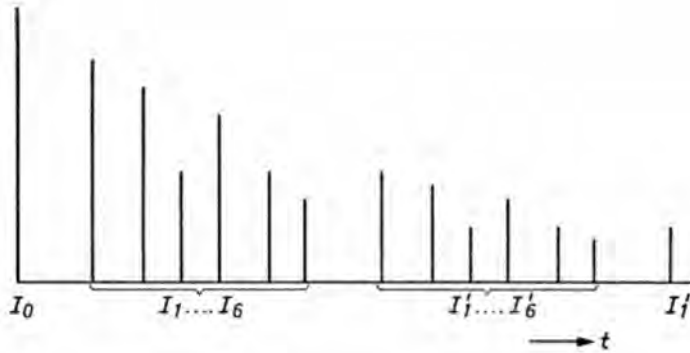

Fig. 3.28: Graph illustrating the functioning of the Philips electronic reverberation system. If a report (pulse  $I_0$ ) is produced in a hall with stereo reverberation, the six loudspeaker groups deliver the six reports  $I_1$ – $I_6$ . If electrical feedback is applied from the sixth playback head to the recording head, the loudspeakers give a second series of six reports ( $I'_1$ – $I'_6$ ), a third, and so on. From “Philips Technical Review,” July–August 1955.

Although Raaijmakers wasn’t aware of it at the time he was making *Canon 1*, he later agreed that the whole idea of sound morphity was strongly related to his experiences with the concert-hall artificial reverberation system Vermeulen had developed at Philips Research Laboratories in the 1950s (see Chapter 2, 53–9).<sup>333</sup> Not only did that system work by using repetitions of sounds with different delay times, but those repetitions were played back through loudspeaker arrays surrounding the audience. Moreover, electronic impulses were used instead of music to calibrate the reverberation systems, as to make the repeated sounds from the loudspeakers individually audible. In his days as a technician at Philips, Raaijmakers’ responsibilities had included demonstrating and maintaining these systems.

In the chapter “Spatial Sound: From the Smallest Sound to Liquid Form” in *Cahier “M”: A Brief Morphology of Electric Sound* (2000), Raaijmakers returned to the subject once more:

Temporal superpositions of points, impulses and needles lead to the emergence of sound-textures which are the basis of a controlled morphological music. This music owes its plasticity not to the activation of passive sounding bodies, as is normally the case, but to the effect which arises when sound-particles, in this case electrical impulses, are superimposed upon one another and generate a mutual interference effect. [...] Present-day loudspeakers, whose construction may still essentially be traced back to nineteenth-century electromagnetic principle, are quite inadequate for the reproduction of these neo-spatial sounds,

which must await a presently unimaginable (because multidimensional) “holo-  
phonic” technology. Only then can our contemporary one-dimensional means  
of electronic sound-generation be consigned to oblivion. Until that time, we  
must resort to models which, to be sure, cannot in themselves be made audible,  
but which are still capable of making visible and tangible the preconditions for  
their audibility.<sup>334</sup>

While Raaijmakers was immersed in the problematics of sound morphology, Bruynèl started working on *Reliëf* (1964) for organ and four sound tracks. To produce the sound material for *Reliëf*, Bruynèl made use of an electronic monochord similar to the one Raaijmakers and Boerman had in their studio in The Hague (see fig. 3.25). For *Reliëf*, the string of the monochord was excited by white noise and the result recorded twenty times, with the tuning of the string changed for every new recording. The twenty recordings were mixed, and together they constituted the basic sound for the tape part of *Reliëf*.<sup>335</sup> Bruynèl used a tape recorder with a variable playback speed to transpose this material at nine equal intervals within an octave. He then used seven bandpasses, from 88 Hz to 5,600 Hz, of a Peekel octave filter to vary the frequency content of the material over time. These filtered sound structures also occur in the piece after being transposed one or two octaves up, so that the total frequency range of the sound consists of filter bands with center frequencies from 88 Hz to 22,400 Hz.<sup>336</sup>

The instrumental part of *Reliëf* is performed by an organist, with two additional people controlling the registers and an assistant, who sometimes plays one of the manuals as well. The organ part consists mainly of tone clusters in which notes subtly exchange places. The sounding of individual notes is deliberately avoided; the work passes by as a mass of sound, the organ clusters blending considerably with the taped noise sounds. The blending of organ and electronic sounds is intensified by the fact that the pitch ranges of the clusters played on the organ move in parallel with the filter ranges of the electronic sounds. Bruynèl worked on the score for eighteen months.<sup>337</sup> Both the taped part and the organ part were notated graphically on large sheets of graph paper, so that the organist could play using the taped part as a reference.<sup>338</sup>

Although *Reliëf* was written to be performed live, it proved difficult to find churches and musicians willing to present the piece. Instead, it premiered at Amsterdam’s Stedelijk Museum in a version for tape alone, with an enlarged copy of the graphical score displayed on the walls. The organ part was recorded on the night of November 27, 1964, by a team from STEM<sup>339</sup> at the St. Jan Basilica in Den Bosch with the organist Huub ten Hacken (1930–2016), and was then mixed with the four sound tracks at STEM.

Whereas Raaijmakers had great admiration for Boerman’s ability to shape sound, Boerman strongly opposed the ideas about sound morphology that Raaijmakers was developing.<sup>340</sup> Nevertheless, he quickly adopted the sound multiplication technique that Raaijmakers had started experimenting with, and after Raaijmakers explained the technique to Bruynèl, he started applying it as well.<sup>341</sup> Making multiple copies of a recorded sound and

then playing back those copies simultaneously on several tape recorders was generally referred to as “auto-synchronization.” The richness of the resulting sound variation was caused not only by the multiplication of the sound itself but in fact mostly by interferences

resulting from inaccuracies in the playback speed of analogue tape recorders (later generally referred to as the flanging effect). This technique had been used at the electronic music studio in Cologne at least since 1959, notably during production of Stockhausen’s *Kontakte*.<sup>342</sup> And since Spek had worked on the realization score of *Kontakte* from the moment he became Stockhausen’s assistant in August 1963, it is very likely that both the technique and the terminology reached Raaijmakers through his regular contact with Spek.

Raaijmakers’ decision to concentrate exclusively on the very elementary material of electronic impulses and their systematic multiplication was partly caused by the fact that he felt intimidated by the relative ease with which Boerman created music in their shared studio:

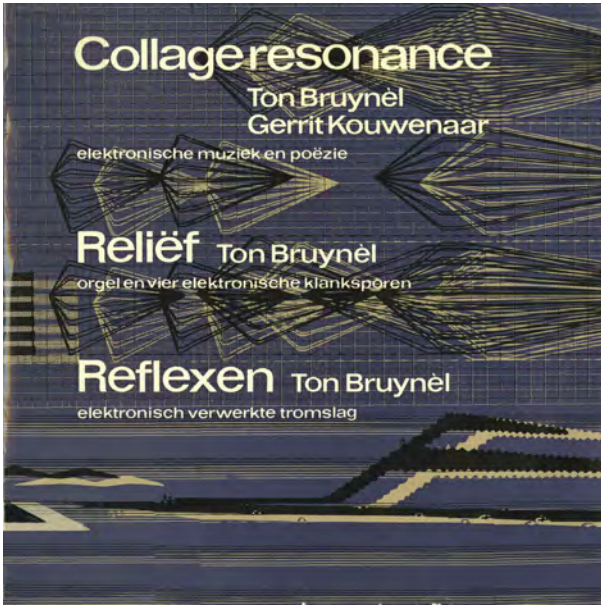

Fig. 3.29: Cover of a phonograph record of works by Ton Bruynèl. The graphical score for *Reliëf* is used as a background. From bottom to top the five systems for the organ (which according to the score are: pedal division, Rückwerk, great division, Oberwerk, swell division) and the twenty-one octave bandpass filter ranges (88 Hz up to 22,400 Hz) in which the electronic sound material can occur.

I know now for certain that I will never be able to make sounds the way that Jan can. Jan’s talent for this is exceptional, and when he does it he forgets everything, absorbed like a child. The exceptional thing is that he does not create sounds that are tendentious in character, as Bruynèl does, but what I would call authentic forms that are completely real – completely Jan, just as a Bruckner symphony is completely Bruckner. [...]

I work much more deliberately than Jan; I am actually aware of everything as I work. This is because I have no ability. I mean ability in the sense of skill: sound-making skill.<sup>343</sup>

Boerman had by now started to work on what would become the key work in his oeuvre: *De Zee* (The sea). Like Raaijmakers, he had not been prevented by the limited technical capacity of their private studio from applying a complex compositional strategy. While he had already used durational proportions based on the golden section in some parts of *Alchemie 1961*, such proportions made up the structural basis of the entire formal design of *De Zee*. Two quantities can be said to be in the golden ratio if the ratio of their sum to the larger quantity is equal to the ratio of the larger quantity to the smaller one. Or,  $(a + b):a = a:b = \varphi$ . The value of  $\varphi$  is then 1.6180339887... However, such a value is difficult to work with in a situation where the duration of a sound is determined by cutting a piece of magnetic recording tape. Boerman therefore decided to base his time structures on so-called Fibonacci sequences. By definition, the first two numbers of such a sequence are 0 and 1, and each subsequent number is the sum of the previous two: 0, 1, 1, 2, 3, 5, 8, 13, 21, 34, 55, 89, 144 and so on. Interestingly enough, the further one proceeds in the sequence, the more closely the golden ratio is approached, yet the values in the Fibonacci sequence are convenient to apply when one is cutting tape.<sup>344</sup> In *De Zee*, the highest selected value in the sequence equals the total length of the composition in centimeters, while the shortest value, 1, equals 1 cm of tape.<sup>345</sup> The formal design of *De Zee* is determined by an arch scheme that represents the piece's subdivisions, from the large form to the smallest elements.

Boerman explains the use of this system as follows:

The form of the work is determined by the arch scheme but it is as if the piece exceeds the boundaries of the scheme; there is no beginning and no end. The smallest block in this scheme is a "shaped sound." By this I mean a resounding movement-form which can be seen as a unit. The sounds have been combined in such a way that a new, more structured form of movement emerges, whose dynamic and spectral aspects comply with the grid of the Golden Section. This frame – the intersections of the arches – operates as an obstacle, a wave-breaker in a stream, provoking movement and counter-movement.<sup>346</sup>

Boerman later said that he had never thought of the sea while working on *De Zee*, though he agreed that the way energy discharged in the piece and wavelike movements suddenly turned over and drained away were oceanlike. The title was proposed by Raaijmakers after the work was finished.<sup>347</sup>

When the choreographer Rudi van Dantzig (1933–2012) had heard Boerman's *Alchemie 1961* at one of the Mood Engineering Society's concerts in February 1962, it had inspired him to collaborate with Boerman by creating a choreography based on the specific characteristics of the composition.<sup>348</sup> The result was the ballet *Monument voor een gestorven jongen* (Monument for a dead boy). Boerman worked on the music in parallel with *De Zee*, ending up with a composition almost twice as long as the original version of *Alchemie 1961*. The Dutch

National Ballet premiered *Monument voor een gestorven jongen* on June 19, 1965, at the Holland Festival in Amsterdam.<sup>349</sup> It became one of Van Dantzig's best-known ballets and was performed all over the world, sometimes with the Russian dancer Rudolf Nureyev (1938–1993) in the principal role.<sup>350</sup> Up to the present day, no other work of Boerman's has been performed as often as the music for this ballet.

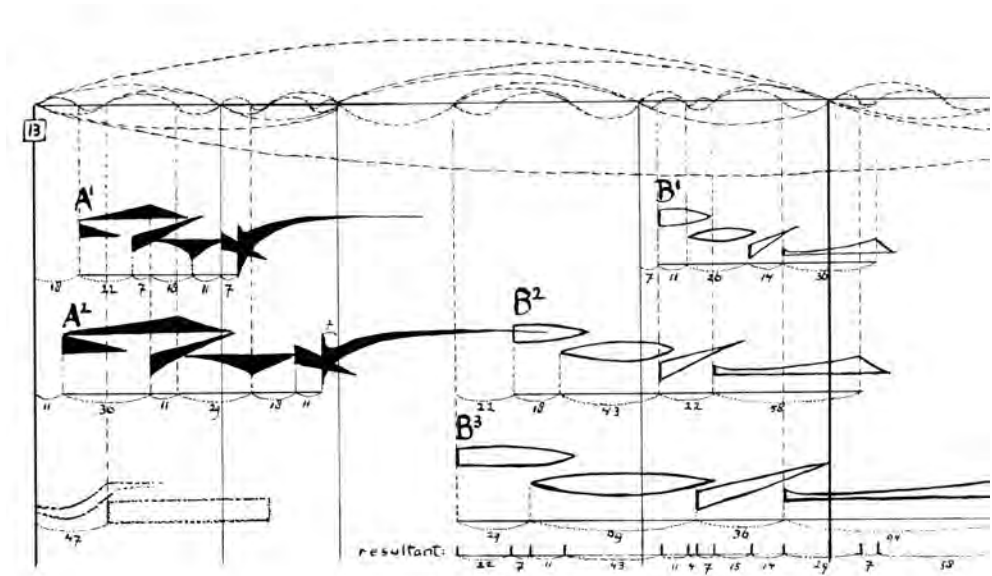

Fig. 3.30: Sketch for "De Zee" with arches illustrating the subdivisive system based on the golden ratio.

## Chapter 12

### Towards Stability in Utrecht and The Hague

#### Gottfried Michael Koenig's Formative Years

Even before its first season was over, it was clear that Koenig's electronic music course in Bilthoven was a success. Meanwhile, STEM was deep in crisis. Apart from the lessons that Badings gave for his Utrecht University musicology students, there was still no educational program at STEM. Moreover, Badings was frequently absent because of his professorship in Stuttgart, his second journey to Australia and his lectures at Point Park College in Pittsburgh. The university's board of governors did not believe Badings' position in Stuttgart could be



combined with his responsibilities in Utrecht, and he was therefore supposed to resign from STEM by the end of the 1962–1963 academic year.<sup>351</sup> In May 1963, Des Tombe asked Koenig whether he was interested in taking over Badings' position at STEM.<sup>352</sup>

In Germany, Koenig had studied church music in Braunschweig and composition, piano, analysis and acoustics in Detmold before deciding in 1950 to fully dedicate his life to composition. In the summer of 1951, he had visited the International Summer Course for New Music in Darmstadt,<sup>353</sup> where the first part of his ballet music *Horae* (1950) was performed, with Hermann Scherchen conducting.<sup>354</sup> In Darmstadt, Koenig had his first experience with music composed according to the serial technique when Karel Goeyvaerts (1923–1993) and Karlheinz Stockhausen performed the second movement of Goeyvaerts' *Sonata for Two Pianos* (1950–1951) in the Arbeitsgemeinschaft für freie Komposition (Work group for free composition), which was supervised by the philosopher and composer Theodor W. Adorno (1903–1969).<sup>355</sup> It was during the same Summer Course that Koenig heard Meyer-Eppler's examples of synthetic sound production models, which were presented at the historic Musik und Technik seminar along with lectures by Robert Beyer, Herbert Eimert, Friedrich Trautwein, Adorno and Pierre Schaeffer.

Schaeffer also gave the German premiere of *Symphonie pour un homme seul* (Symphony for a man alone) (1949–1950), composed with Pierre Henry, which was welcomed with enthusiasm in Darmstadt.<sup>356</sup> Another work by Schaeffer and Henry, the 42-minute *Orphée 53* (1951), was performed on the same day. While French *musique concrète* and German *elektronische Musik* are usually seen as fundamental opposites, *musique concrète* initially had a more prominent place than *elektronische Musik* in the concert programs of Darmstadt, the cradle of serialism. From 1951 to 1953, five complete works from the studio in Paris and two films with music produced there were presented in the Darmstadt concerts, while pieces from Cologne were played only as sound examples during lectures.<sup>357</sup>

Some weeks after the 1951 Summer Course, Koenig decided to write Meyer-Eppler a letter. Although he had initially been disappointed by the sonic examples presented, he said, he had eventually come to understand that embedded in the method of electronic music production Meyer-Eppler proposed was a promising future: "Like painting and literature, music now finally has the opportunity to do away with mediation [by interpreters]."<sup>358</sup> In his own compositional practice, Koenig had arrived at a point from which he could not develop further without the new possibilities afforded by electronic sound production. He could no longer create the sounds he imagined using a traditional orchestra, and he therefore asked Meyer-Eppler urgently whether he could offer him an opportunity to work in this new area. Koenig was, he said, "determined to work with the means of producing electronic sounds as soon as they [became] available to him."<sup>359</sup>

Meyer-Eppler replied that Koenig might be able to take a short course (three mornings or afternoons) on the technical fundamentals of electronic music at his Institut für Phonetik und Kommunikationsforschung (Institute for phonetics and communication research). Because of

the limited availability of rooms, he could offer nothing more. However, NWDR in Cologne would soon have a trauttonium, and Meyer-Eppler assumed that it would therefore be possible to realize complete electronic compositions there. He suggested Koenig contact Herbert Eimert in Cologne.<sup>360</sup>

Koenig wrote Eimert a letter two days later to ask if and when there might be an opportunity for him to gain practical experience with electronic music instruments and techniques in Cologne. In addition to the arguments he had made in his letter to Meyer-Eppler, which had mostly concerned sound, he explained that when harmony, counterpoint and standardized form schemas for the organization of “musical phenomena” were inadequate, electronic music could offer a way out of the inherent impasse of traditional modes of composition.<sup>361</sup> In a second letter to Eimert, he added, “The new world of sounds requires a new technique, or rather, as we hear music differently, we see ourselves obliged to resort to electronic equipment.”<sup>362</sup> Koenig also addressed the “noise music” of Pierre Schaeffer:

His *Symphonie pour un homme seule* exhibits so much perfection and poignancy, that the surrealist noise montage could be a cliff modern composers will not easily circumnavigate. I think Schaeffer’s experiments are very interesting and fundamental; my personal concern is based on my interest in the literary surrealism. But those experiments might be unique as there are things one cannot repeat without imitating them. It should be understood that music begins with abstracting chaotic noise to “tone.” Since then we have a history of music. There is no history of noise and never will be.<sup>363</sup>

The young Koenig was indeed interested in literature. He had written many poems and stories and had serious plans to continue doing so. In fact, his literary and musical aspirations were at that time equally balanced.<sup>364</sup> When the writer and filmmaker Jean Cocteau (1889–1963) visited Germany in January 1951, he publicly discussed plans for the establishment of an international youth broadcasting studio. By April, the German part of the organization was set up in Stuttgart. All the German broadcasting companies were willing to cooperate, and so were most other European and American ones. The radio studio was to be granted airtime soon, and broadcasts were to take place without censorship or editing of its authors’ literary or musical contributions. Its main purpose would be to produce “a genuine radio art that merges words, sounds and music into a new whole.”<sup>365</sup> Koenig read about these plans in a German broadcasting magazine and wrote Cocteau a letter, in which he mentioned that he had contacted the organization’s authors in Stuttgart and wanted to collaborate. Koenig believed the studio would be “a mouthpiece for those not given the opportunity to speak by the regular art ‘industry,’” and “a laboratory, similar to the Club d’Essai in Paris, for those concerned with an authentic form of literature and music for radio.”<sup>366</sup> Koenig wanted to do what he could to further a kind of art that would “make use of the technical possibilities of broadcast and montage as materials.”<sup>367</sup>

When Koenig wrote to Cocteau, he had just finished composing an orchestral work for "Ausdruckstanz" (expressionist dance),<sup>368</sup> entitled *Reading Gaol*<sup>369</sup> after the poem *The Ballad of Reading Gaol* (1898)<sup>370</sup> by Oscar Wilde (1854–1900). Koenig believed he had now managed to achieve in music what he had so far failed to do in literature: to create something new that belonged entirely to him.<sup>371</sup> In his letter to Cocteau, he explained that

the score treats the twelve-tone material as an underpainting, while the structure of the music as a whole is one of color. Just as with the old masters, one layer is put on top of another; every compositional step is judged on the qualities of its color and then introduced accordingly. The final "image" results from the instrumentation (for orchestra), or even better, from a conversion into electronic sound.<sup>372</sup>

Koenig's compositional practice was now based almost exclusively on numerical tables. This way of working had been inspired by his encounters with electronic music but had developed into a compositional technique that was independent of the use of electronic instruments. "Of course, these scores are better interpreted electronically [...]; nevertheless, it is also possible to write original scores for orchestra in this way," he wrote.<sup>373</sup> Koenig was convinced that electronic music would meet with great interest at the new international youth radio studio. There, he hoped finally to find the working environment he had so long wished for, and he wanted to execute the *Reading Gaol* score with electronic sounds as soon as it was possible to work in the studio.<sup>374</sup> In June, still waiting for the studio to be installed, Koenig wrote to the broadcasting companies NWDR in Hamburg and RIAS in Berlin to make requests regarding electronic music, but without results.<sup>375</sup> By the time Koenig attended the next International Summer Course for New Music, in August 1952,<sup>376</sup> it had become clear that the youth radio studio would essentially be oriented towards literature and not music.<sup>377</sup> Instead of using electronic sounds, he therefore finished *Reading Gaol* as a composition for orchestra.<sup>378</sup>

After his many unsuccessful attempts to get access to an electronic studio, Koenig once again concentrated on instrumental music. He had started working on a series of three orchestral compositions before attending the 1952 Summer Course, and he finished the first one by mid-August.<sup>379</sup> In November, before completing the orchestra pieces, he began composing a piano concerto.<sup>380</sup> Between December 1952 and October 1953, he made numerous attempts to get his instrumental works performed. He sent no fewer than seven scores, including the ballet music *Horae*, two of the *Drei Orchesterstücke*, and *Reading Gaol*, to broadcasting companies such as RIAS, NWDR, Radio Bremen, Süddeutscher Rundfunk in Stuttgart, Hessischer Rundfunk in Frankfurt, and Bayerischer Rundfunk in Munich. Although the scores were sometimes received with interest, his attempts did not result in any performances.<sup>381</sup>

Towards the end of 1953, Heinz Wiens, a former fellow student of Koenig's in Detmold, found out about a new educational program at the Institut für musisch-technische Gestaltung (Institute for musical-technical design) of the Staatliche Hochschule für Musik in Cologne, su-

pervised by the recording engineer Walter Michael Berten (1902–1956). The admission requirements were high: out of two hundred applicants, only eighteen were selected for an admission exam. Koenig was one of them; it helped that his composition *Horea* had been conducted by Hermann Scherchen in Darmstadt.<sup>382</sup> Koenig met Berten twice in November 1953, and when he showed him some of his scores, Berten's response was very positive. As Meyer-Eppler had, Berten advised Koenig to contact Eimert, who had a studio where "such things could be tried out."<sup>383</sup> The admissions exam for Berten's institute took place in March, and Koenig was accepted. The group of eleven students consisted of musicians, musicologists and technicians, with Koenig the only composer among them.<sup>384</sup>

The semester at Berten's institute began on May 4, 1954, with a lecture on technology and musical aesthetics by Friedrich Trautwein (whom Koenig knew from Darmstadt and the Tonmeistertagung in Detmold).<sup>385</sup> At the end of the day, the NWDR engineer Fritz Enkel (1908–1959) gave a lecture on the construction and operation of electroacoustic equipment, which was followed a few days later by a guided tour of NWDR's technical facilities.<sup>386</sup> Between thirty and forty guest instructors were engaged.<sup>387</sup> Koenig was initially enthusiastic about Berten's institute.<sup>388</sup> However, only two months after the semester had started, Koenig took steps to get access to NWDR's electronic music studio. He visited Eimert, who was open to his working there, and they scheduled a further discussion for July 16, 1954.<sup>389</sup> Eimert then gave Koenig permission to use the studio for the electronic production of a score as soon as Stockhausen, Henri Pousseur and Paul Gredinger were finished with their compositions.<sup>390</sup>

## Koenig at the Cologne Studio

At the time of Koenig's meeting with Eimert, the staff of the Cologne electronic music studio consisted of Eimert as director, the technical chief Fritz Enkel and the technicians Heinz Schütz and Erhard Hafner. Stockhausen was commissioned to compose there and also had a permanent position realizing the scores of other composers. In addition, there was a research program, and Stockhausen was not able to continue fulfilling all these obligations. Eimert was therefore looking for an additional staff member with a background in music, whose job would be comparable to that of a conductor in the sense that he would be responsible for executing works by others. Eimert allowed Koenig to work in the studio for four weeks without pay while he became familiar with technical procedures. He immediately began assisting Stockhausen, and they got along well.<sup>391</sup>

In September, Koenig began composing the score for what would become his first electronic composition: *Klangfiguren I* (1955). Although he later rejected the piece, its technical realization provided him with an essential experience in his development as a composer. The general practice in electronic music studios at the time was to compose timbres out of single sine wave components, which was a complicated and time-consuming affair. The studio had only one sine wave generator available, and it was not even located in the studio itself but in

the room for *Meßtechnik* (measuring technique). To record sine waves of specific frequencies, two people were needed: one to adjust the generator to the desired frequencies and the other to record its output in the studio, while they communicated through a telephone line.<sup>392</sup> If a sound was supposed to have five sine wave components of different frequencies, the first component would be recorded on tape and then copied to another tape as the second was mixed in, and so on. To speed up this process, the technician Schütz suggested changing the order of the heads on a tape recorder from the normal erase-record-play to play-erase-record. A tone mixture could then be efficiently built up on a single machine. Koenig used this so-called *Kopierkopf* (copy head) configuration to build up the entire structure of *Klangfiguren I*. He spliced the individual layers according to the numerical score and then mixed them one by one using the modified tape recorder. He took great pleasure in hearing his work gradually come into being without lifting a finger. The production of *Klangfiguren I*, he said, “showed that through stacking, formations arise that one later experiences only as a consequence of sonic events. Conversely, one can conclude that any sequence of sounds [...] can be understood as a result of stacking.”<sup>393</sup> This description brings to mind Koenig’s conception of *Reading Gaol* in 1951. In his letter to Cocteau, he had explained how he had added layers in the score one by one, judging each compositional step on its color qualities and adjusting it accordingly. While the final piece was the result of orchestral instrumentation, he suggested it would have been even better converted into electronic sound.<sup>394</sup>

Eimert was enthusiastic about this first electronic work of Koenig’s, especially since it was quite different from the other compositions realized in Cologne so far. Koenig was appointed as a technical staff member in February 1955 and decided to end his studies at Berten’s Institut für musisch-technische Gestaltung the next month.<sup>395</sup> Since Eimert knew that Koenig was also a gifted writer, he immediately asked him to write an article about tape recorder technique from a compositional perspective for a journal he planned to publish with Universal Edition. That journal was *die Reihe*, and Koenig’s piece, “Studiotechnik” (Studio technique), appeared in the first issue. The article touches on subjects Koenig would later address regularly, such as the interdependency of compositional ideas and technical practice, the automation of the production process, and something that in retrospect we can understand as computerized sound synthesis, though he did not call it that:

[R]esearch should be made into mechanical or photo-electric automation, which could be controlled by some adequate notation. [...] Directly, without any electromagnetic processing and storage, the final composition would be converted into sound that is technically immaculate. [...]

The realization of electronic music is entirely conditioned by [its] dual musico-technical character. To consider both the realization of a given score and the artistic application of technical structural methods pushes ahead both music and working methods.<sup>396</sup>

The second part of this statement perfectly characterizes Koenig's subsequent electronic works, which would employ the systematic derivation of variants from basic material by means of technical processes more prominently with every new composition (*Klangfiguren II* in 1955–1956, *Essay* in 1957, *Terminus I* in 1962, *Terminus II* in 1966–1967 and *Funktionen* in 1967–1969), steadily lessening the need for the splicing of magnetic tape and the manual operation of single devices.<sup>397</sup> These compositions, by the way, are all based on pure electronic sounds and include no material recorded using microphones.

Koenig's main job in the studio, however, was not to compose but to technically realize scores written by other composers. In that sense, his role was not so different from Raaijmakers' at Philips Research Laboratories, although Raaijmakers mainly assisted one composer, Badings, while Koenig assisted many. Between 1955 and 1962, he served as a technician for Giselher Klebe (1925–2009), Bengt Hambraeus (1928–2000), Stockhausen, Ernst Krenek (1900–1991), Herbert Brün (1918–2000), Franco Evangelisti (1926–1980), György Ligeti, Bo Nilsson (1937–2018),<sup>398</sup> Cornelius Cardew (1936–1981), Mauricio Kagel (1931–2008) and Konrad Boehmer.

Whereas most of these composers' compositions were short and produced within several weeks, Koenig's intensive collaboration with Stockhausen in the realization of *Gesang der Jünglinge* (initially referred to as "Messe") began in April 1955 and was expected to take a full year's work.<sup>399</sup> The combination of Stockhausen's detailed serial conception and the fully manual production techniques of the time made its realization extremely complex. It sometimes took the men a full month to produce just twenty seconds of music.<sup>400</sup> Nevertheless, Koenig said he enjoyed working with Stockhausen.

Working with Stockhausen is a great pleasure [...]. He is very inspiring, enthusiastic and obsessed with ideas. A very good friend, too [...], with whom it is possible to work hand in hand. We hardly talk to each other [during work], only exchanging instructions and questions. To have time for discussion, we pause the work for half an hour, sometimes even an hour. This allows us to truly achieve something.<sup>401</sup>

An even more ambitious project was the realization of Stockhausen's 35-minute *Kontakte*, which took from February 1958 until May 1960.<sup>402</sup> While Koenig greeted Stockhausen's conception of this work with as much enthusiasm as before, it made him even more aware of a fundamental problem with manual production techniques. They required every individual sound structure to be made from scratch, starting with the recording, splicing and synchronization of the smallest components, such as sine waves and filtered impulses. In spite of the fact that these structures were made according to different schemes, they often shared common characteristics. For Koenig, this indicated that there ought to be more efficient ways of communicating these schemes to the studio's equipment. Why were composers still sentenced to performing all this manual labor while surrounded by sophisticated machines? It is



therefore significant that Koenig called the last electronic composition he produced in the Cologne studio *Terminus* (1962) – not because he already planned to leave Cologne but because he saw no further possibilities for composing the fluctuating inner structures of sound as he imagined them using the WDR studio’s manual equipment. In that sense, he had reached an “end station” with *Terminus*.

Work on *Terminus* started in April 1962 (with a performance in Cologne planned for January 10, 1963),<sup>403</sup> the same month that Eimert retired.<sup>404</sup> Otto Tomek (1928–2013), a musicologist and head of the contemporary music department, became responsible for the studio organization, while Stockhausen became its artistic director.<sup>405</sup> However, Stockhausen said he would accept the position only on the condition that 1 million West German marks were made available for the further development of the studio. WDR granted him this amount in installments. A 250,000-mark budget therefore had to be drawn up immediately, but Stockhausen traveled to Finland and asked Koenig to make the budget for him.<sup>406</sup> At the same time, it was becoming clear to Koenig that he and Stockhausen had fundamentally different views on the future of the studio. Whereas Stockhausen had already claimed the exclusive use of the new studio for a full year (with less than four weeks left for Koenig, outside regular working hours only), Koenig did not consider electronic music a privilege for the few. He thought the studio – like the broadcast company it was part of – should be a public institution. The money therefore should not only be spent on new equipment but should also be used to increase the working capacity of the studio, paying for larger spaces and at least one additional technician and an engineer.<sup>407</sup>

Technically, too, Koenig’s ideas were developing in a different direction from Stockhausen’s. Koenig had already been thinking about using a computer for musical purposes for several years when the possibility of expanding the Cologne studio arrived, and he now hoped to enter into a partnership with a large IBM facility. He had found specialists to discuss his ideas, which appeared possible to realize technically.<sup>408</sup> In September 1963, Koenig began attending a course in the building and programming of electronic data-processing equipment at the Rheinisch-Westfälisches Institut für instrumentelle Mathematik at the University of Bonn with Fritz Krückeberg (1928–2012). The course involved technical assignments, such as the calculation of formulas for combustion processes in diesel engines, which Koenig was permitted to replace with examples from music. He created a program for the calculation of harmonic problems, and subsequently one to calculate the permutations of twelve-tone rows, inspired by the discussions about serial composition techniques in Darmstadt. These exercises later developed into the algorithmic composition program Project 1. Koenig had actually wanted to use a computer to synthesize sounds and discussed his ideas with Krückeberg. The IBM mainframe computer was capable of making the necessary calculations, but there was no digital-to-analog converter to make the calculated sounds audible. Another problem was that the data flow had to be stored on magnetic tape in blocks that were interrupted by “record gaps.” These gaps caused audible clicks during playback.<sup>409</sup>

In the meantime, Stockhausen had visited several European and American studios to collect information about their working methods.<sup>410</sup> In February 1964, with construction work on the new studio about to start, it was decided that 500,000 German marks would be spent, half on the construction itself and the other half on new equipment, to include a large twenty-channel mixing desk. The installation of automatically controlled machinery (which Koenig had wished for) had not been considered, and as a result, working methods in the studio would remain unchanged. Nevertheless, Koenig had completed a detailed proposal for the use of a computer. He had discussed his plans with mathematicians and physicists and found engineers and companies that were willing to design and build the necessary equipment. But when Stockhausen returned from the United States, Koenig realized it would be pointless to discuss these plans with him any further.<sup>411</sup> Through his studies at the University of Bonn, he now had access to a computer there, and he started to work on Project 1 with the help of Jaap Spek, who had arrived in Cologne in August 1963 to work as Stockhausen's new assistant (see Chapter 11, 231–46).<sup>412</sup>

Apart from these artistic and technical considerations, there was yet another factor that made Koenig doubt his future in Cologne. From the moment he had started to work at the NWDR/WDR studio, he had been paid on the basis of temporary contracts, and in spite of his important contributions to the realization of works such as *Gesang der Jünglinge* and *Kontakte*, time after time, he was uncertain whether or not his contract would be extended. Eimert himself had no budget for the studio, and although Koenig's function was primarily technical, without a technical diploma, the union would not allow him to be given a permanent position in the department. Eimert had to make regular applications for Koenig's stipend, and Koenig often had to remind him.<sup>413</sup>

The music critic and theorist Heinz-Klaus Metzger (1932–2009), who was familiar with Koenig's situation, suggested in December 1957 that he consider Schaeffer's Club d'Essai in Paris as an alternative to the studio (Metzger had studied composition in Paris with Max Deutsch (1892–1982) and still had many contacts in the French capital). Although Koenig was seriously considering making a change in the short term and welcomed all offers, he wasn't very interested in the Club d'Essai. Scherchen had also expressed his admiration for Koenig's technical virtuosity, and Koenig expected to be invited to visit his studios in Gravesano.<sup>414</sup> In July 1958, Metzger heard that the writer and politician André Malraux (1901–1976) planned to establish a new studio in Paris under the direction of Varèse (who was then in Paris, just having finished his work at the Brussels World's Fair). Metzger wrote to Koenig:

Malraux, De Gaulle's right-hand man,<sup>415</sup> finally brings me some joy. He would like to set up a state-funded electronic studio under the direction of Varèse in Paris – I have recommended you to Varèse as a colleague. Please get in touch with him if you are interested in this possibility.<sup>416</sup>

Koenig again chose not to pursue Metzger's suggestion, possibly because he was gradually becoming involved in education at the Staatliche Hochschule für Musik in Cologne, where Bernd Alois Zimmermann (1918–1970) had just succeeded Frank Martin (1890–1974) as professor in composition. Zimmermann had greatly appreciated Koenig's *Klangfiguren I* when it was performed in Darmstadt in 1955, and Koenig had deemed Zimmermann's *Perspektiven* (1955) for two pianos one of the best works presented at the International Summer Course that year.<sup>417</sup> The two had often met at NWDR/WDR since then.

Zimmermann was starting a seminar for theater, film and radio music at the college, and he wanted to introduce his students to electronic music. He therefore asked Koenig to give lectures on the subject. The college did not have a studio, so Koenig gave technical explanations and audio examples of compositions produced at WDR, but no practicals. These incidental lectures resulted in Koenig being offered a teaching position starting in 1962, simultaneously with the beginning of his first course in Bilthoven. The students at the college were now allowed to conduct experiments in the WDR studio, one at a time. When Zimmermann was awarded a fellowship at the German academy Villa Massimo in Rome a year later,<sup>418</sup> he asked Koenig to temporarily take over his professorship in composition and analysis at the college in Cologne.<sup>419</sup>

## **Koenig at STEM**

Koenig was also being appreciated more and more for his educational work in the Netherlands. Des Tombe's suggestion in May 1963 that Koenig take over the STEM directorship from Badings was certainly attractive to Koenig from an artistic point of view, but whether opportunities in the Netherlands would be reason enough for him to leave Cologne remained to be seen. In a letter to CEM chairman Bomli on May 5, 1963, Koenig said he was considering a move to the Netherlands if he were to continue as supervisor of the Bilthoven course in combination with becoming artistic director of STEM. That situation would also allow for close collaboration between the educational studio in Bilthoven and the production studio in Utrecht.<sup>420</sup>

Koenig was beginning to investigate the possibilities for using computers for musical purposes in the Netherlands. In a letter to Des Tombe, written on the same day as the one to Bomli, he described how his plans for digital sound production had originally begun as a private project. And now that he was about to realize these plans practically at an electronic music studio, two things were occurring: the studio in Cologne was in the middle of a reorganization and Des Tombe was asking him to succeed Badings as director of STEM. He wanted Des Tombe to understand that the computer studio he was proposing would not make STEM's traditional studio obsolete. On the contrary, that studio should be expanded further. It would be several years before the first results in computerized music production could be expected, many works would also have to be produced for which the computer would prove unsuitable, and the computer would primarily be used for making sounds that were impossible to produce

using traditional techniques. Koenig's letter to Des Tombe ended with an overview of the tasks that the studio in Utrecht would engage in should he become its head. The technical installation would include a production studio, a four-channel monitoring room, a workshop, an archive, a microphone recording room and a computer studio, for which a digital-to-analog converter would have to be built. Operations would include electronic composition, research and experiments; collaborations with radio, television and film; and possibly research commissions as an equivalent to scholarships or composition commissions for talented composers. Furthermore, STEM would have an educational function, teaching subjects such as the history of electronic music, the analysis of existing works, studio working methods, the description of sound according to serial composition techniques, and general composition theory. STEM would also produce theoretical writings, records, concerts, and radio broadcasts on all the important stations in the Netherlands and abroad.<sup>421</sup>

On June 30, 1963, Koenig wrote a long letter to Hendrik Casimir at Philips, again explaining why computers were important for the further development of electronic music:

Although I am a musician originally, I have always been interested in technical problems, especially in the possibility to bring sound in a relationship with the form development, and to be able to describe both the sound itself and the previously mentioned relationship accurately. [...]

The question that concerns me for years now is how

1. the range of novel sounds can be increased;
2. the composer can have an even larger control over his material and
3. the technical work with the equipment in the studio can be simplified.

[...]

The theoretical aspect [...] also includes the individual amplitude and the time interval to the next. However, the traditional tape technology does not make this [micro time] domain accessible. On the contrary, the more the base material is subjected to transformations by filtering, reverberation or modulation, the more the result will be uncontrollable, the greater the amount of work, the more the technical quality suffers due to the multiple [analog tape] copies. Electronic music [thus] ends up as a kind of instrumental music with different instruments.<sup>422</sup>

While Koenig was only able to formulate his ideas theoretically, he hoped that Casimir, being a specialist in this area and a leading figure at a multinational electronics company, would be able to judge their practical ramifications.<sup>423</sup> Casimir found Koenig's letter interesting, and they agreed to meet personally and discuss things further. Their meeting took place on September 7, 1963, at Casimir's house,<sup>424</sup> and from the conversation, Koenig concluded that Casimir considered his plans realistic. Koenig continued his discussions in Utrecht in December, and it was decided that he would become artistic director of the studio in mid-1964.<sup>425</sup>



Fig. 3.31: Gaudeamus Muziekweek participants visit STEM in September 1964. From left: Gottfried Michael Koenig, Frank de Vries, Walter Maas and Earle Brown (staring at the ground). Sixth from right: Jan van Vlijmen.

According to a letter written by Spek (who had been in Cologne since August 1963) to Raaijmakers on January 17, 1964, Koenig was appointed thanks to much agitation by Maas and the moral support of Des Tombe and Casimir, and in spite of opposition by Reeser, who had heard from Escher that Koenig was a bad teacher.<sup>426</sup> Escher must have been aware, though, of the success of the Bilthoven course. He was apparently unable to overcome his frustration regarding his own numerous unsuccessful attempts to become involved in electronic music research at Utrecht University.

Spek also wrote that he had suddenly become close to Koenig, who had explained his work with the IBM 7090 computer at the University of Bonn to him. According to Spek, Koenig was aware of the same problems as Raaijmakers was (see Chapter 11, 231–46) but was approaching them from a different perspective, concentrating on the programming of structures based on serialism that for now still had to be performed with traditional instruments. Spek and Koenig had discussed “structure generators with inputs *and* outputs.”<sup>427</sup>

When Badings resigned, his position as director of STEM was split in two. Koenig moved from Cologne to Utrecht on July 13, 1964, and started working as artistic director of STEM on September 1, while Frank de Vries (1909–2004) was appointed studio manager. Just as Koenig had foreseen, collaboration between STEM and the course in Bilthoven intensified. STEM began hosting the course, while its students used the Bilthoven studio for practical assignments, and many compositions that were started there were finished at STEM.

So that he could continue working on his programs, Koenig immediately contacted the Elektronisch Rekencentrum (computer center) at Utrecht University, which had a small Elec-

57  
4

'Struktur' 1  
'Kombination:'

'Parameter: ' 'KLANGFARBE' 'RHYTHMIK' 'TONHOEHE' 'OKTAVLAGE' 'DYNAMIK'  
'Programm : ' 1 6 2 3 3

	'KLANGFARBE'	'RHYTHMIK'				'TONHOEHE'			
		'Tempo'	'EA'	'VN Fermate'					
1	'x'	5	60.0	'x'	4.5			'x'	'CIS' 'C'
2		6			4.5				'A' 'H' 'AIS' 'G' 'E'
3		6			4.5			'x'	'FIS' 'F' 'CIS' 'C' 'H'
4		7			4.5				'G' 'F' 'CIS' 'C' 'H'
5		7			4.5				'DIS'
6		7			4.5				'D' 'AIS'
7		7			4.5				'A' 'GIS' 'E'
8		7			4.5				'G' 'FIS' 'D'
9		7			4.5		1	'x'	'G' 'FIS' 'D'
10	'x'	7	34.5	'x'	4.5				'AIS' 'A'
11		7			4.5				'F'
12		7			4.5				'CIS' 'C' 'GIS' 'E'
13		7			4.5			'x'	'DIS' 'E' 'GIS' 'A' 'A'
14		7			4.5				'D' 'C' 'CIS' 'F' 'F'
15		7			4.5			'x'	'AIS' 'H' 'DIS' 'CIS' 'D'
16		7			4.5				'G' 'GIS' 'C'
17		7			4.5			'x'	'H' 'C' 'DIS' 'AIS' 'A'
18		7		'x'	1.8				'FIS' 'GIS'
19	'x'	7			1.8				'G' 'E'
20		7			1.8				'CIS' 'D'
21		7			1.8				'F' 'D'
22		7			1.8			'x'	'D' 'CIS'
23		7			1.8				'A' 'GIS'
24		7			1.8				'G' 'DIS'
25		7		'x'	1.8				'DIS'
26		7			1.8				'H' 'AIS'
27		7			1.8				'FIS'
28	'x'	7			1.8				'F' 'C'
29		7			1.8				'E' 'C'
30		7			1.8				'A' 'CIS'
31		7			1.8			'x'	'AIS' 'CIS'
32		7			1.8		2		'H' 'C' 'DIS'
33		7	52.0	'x'	1.3				'H' 'C' 'DIS'
34		7			1.3				'FIS' 'F' 'D' 'GIS'
35		7			1.3				'G' 'F' 'D' 'GIS'
36		7			1.3				'G' 'F' 'D' 'GIS'
37	'x'	7			1.3			'x'	'GIS' 'G' 'E'
38		7			1.3				'H' 'E'
39		7			1.3				'C' 'DIS'
40		7			1.3				'A' 'DIS'
41		7			1.3				'AIS' 'CIS'
42		7		'x'	1.3				'FIS' 'F' 'D'
43		7			1.3				'CIS' 'D' 'F'
44		7			1.3			'x'	'C' 'H' 'GIS' 'AIS'
45		7			1.3				'A' 'FIS' 'DIS' 'E'
46	'x'	7			1.3			'x'	'E' 'F'
47		7			1.3				'GIS' 'CIS'
48		7			1.3				'C' 'A' 'DIS'
49		7		'x'	1.8				'D' 'H'
50		7			1.8			'x'	'FIS' 'G'

Fig. 3.32: Printed output from Gottfried Michael Koenig's computer program Project 1: the first page of Koenig's first computer composition, "Projekt 1: Version 1" for small orchestra (1965-1966).





trologica X1 computer that was slated to be replaced with a larger Electrologica X8 in January 1965.<sup>428</sup> Koenig started working regularly at the computer center on a new version of Project 1. Switching from the IBM computer in Bonn to the Electrologica X8 in Utrecht meant learning a new programming language, however, since the X8 worked with ALGOL (ALGOritmic Language) and the IBM 7090 with FORTRAN (FORmula TRANslating system). An additional complication was that Koenig now was much more skeptical regarding the programming of compositional problems than when he had started working with computers in Bonn.<sup>429</sup> Nevertheless, he finished and thoroughly tested the new version of Project 1 in October 1965.<sup>430</sup> He used the program to write a composition for small orchestra called *Projekt 1: Version 1* (1965–1966).<sup>431</sup>



Fig. 3.33: Production studio at STEM as of April 14, 1966.

Using a computer to produce electronic sound was still on Koenig's agenda too. By December 1965, it appeared possible to generate continuous sounds of any desired length without the storage of data on magnetic tape and all its related difficulties (such as sound interruptions).<sup>432</sup> There had been a long discussion at the computer center, and it was determined that the necessary



Fig. 3.34: Luctor Ponse (left) and Ton Bruynèl in Studio 1 at STEM / the Institute of Sonology in 1967, after modernization.

digital-to-analog converter could possibly be bought in the following year or the year after that. The plan was eventually to run special cables from the computer center to the studio. A technician could then run the program at a distance while someone else recorded the sounds from the converter's output. The center had promised to help, and Koenig hoped that the computer would be available for sound synthesis experiments one evening a week.<sup>433</sup> Paradoxically, this working method would to some extent have duplicated the earliest situation in the

Cologne studio, where the sine wave generator was operated in the measuring instruments room while its sound was recorded in the studio. These plans remained unrealized, however.

Koenig nevertheless continued working at the computer center on another program for instrumental composition called Project 2 and a program for computerized sound synthesis (first called CSP 1, later SSP). Project 2 was finished in August 1966, while CSP 1 was under development until beyond July 1968.

Between 1964 and 1967, STEM was renovated, expanded and modernized in three phases. The new studios were officially presented to the press on October 18, 1967, with speeches by Casimir, Des Tombe, Koenig and De Vries. STEM by now had a much larger share of the building on Plompstorengracht, with two production studios, a four-channel studio, a teaching studio and a microphone recording room.<sup>434</sup> Lectures were given in the lecture hall of the Theologisch Instituut (Institute of Theology), which was housed in the same building. The practical duties of the Bilthoven course – whose lessons STEM had been hosting since 1964 – could now be taken over too.<sup>435</sup>

The board of governors of Utrecht University had founded an interfaculty supervisory committee for STEM in 1966, which was chaired by Des Tombe and whose members included Hendrik Casimir and Eduard Reeser. On the day of the official presentation of the new studios, the committee decided to change STEM's name to the Institute of Sonology.<sup>436</sup> STEM had, after all, become much more than a studio for electronic music production. Its activities now included research, education and the organization of concerts, which the university believed should be reflected in a new name.

As a result of Koenig's ongoing efforts, the first year-long sonology course, which began in 1967, featured computer-assisted composition as a special subject.<sup>437</sup> Making computerized sounds finally became possible in 1971, after the installation of a Digital Equipment Corporation (DEC) PDP-15 computer in one of the studios on Plompstorengracht. This triggered the creation of pioneering sound synthesis programs such as POD, by Barry Truax (\*1947); ASP and PILE, by Paul Berg (\*1949); and VOSIM, by Werner Kaegi (\*1926) and Stan Tempelaars (1938–2010).



*Fig. 3.35: PDP-15 computer in Studio 1 at the Institute of Sonology, 1971.*

## Kees van Baaren and the Establishment of a Studio at the Royal Conservatoire

Kees van Baaren (1906–1970) studied composition with Friedrich Koch (1862–1927) in Berlin, where he was introduced to the twelve-tone music of Schoenberg, before becoming a student of Willem Pijper at the Rotterdam Conservatory from 1931 to 1936.<sup>438</sup> He served as director of the Utrechts Conservatorium from 1953 until he was appointed director of the Royal Conservatoire in The Hague on January 1, 1958. His students included Theo Bruins (1929–1993), Jan Wisse (1921–2008), Peter Schat, Jan van Vlijmen, Louis Andriessen, Misha Mengelberg, Maarten Bon (1933–2003), Reinbert de Leeuw, Gilius van Bergeijk (\*1946) and David Porcelijn (\*1947). Van Baaren's oeuvre directly reflects the changes in contemporary music in the Netherlands that occurred between 1945 and 1970.<sup>439</sup>

Although he was certainly not the first Dutch composer to apply twelve-tone and serial methods, as a teacher he played a central role in the propagation and acceptance of these methods. According to Van Baaren, dodecaphony “detaches the sounding material from the hierarchical organization of harmonic functions. The emotional associations these [functions] have acquired over the years obstruct open-minded points of view [on music].”<sup>440</sup> He made his name as a composer of serial music with *Variazioni per orchestra* (1959) and was even considered to be the “father of Dutch serialism.”<sup>441</sup> However, for Van Baaren, the serial technique was nothing more than “a purely technical procedure enabling the composer to rediscover pitch material – which in the course of the nineteenth century had become increasingly encumbered with psychological associations – in terms of sound only.”<sup>442</sup>

Van Baaren had been attending CEM's assemblies as a representative of the Genootschap van Nederlandse Componisten (Dutch composers' association) practically since CEM's establishment in 1956, and when the studio at TH Delft was about to close in December 1959, he investigated the possibility of setting up a working relationship between the Royal Conservatoire and TH Delft.<sup>443</sup> Van Baaren's concern at that time had much to do with the fact that he had four composition students working in Willem Kok's studio.<sup>444</sup> He therefore considered starting a teaching studio in The Hague so that the work that was about to end in Delft could continue.<sup>445</sup> This plan was not realized (presumably because the tasks of Kok's studio were taken over by CEM in Bilthoven), but the idea of a studio at the Royal Conservatoire stayed on his mind. And now that Boerman and Raaijmakers had their private studio in The Hague, electronic music had his full attention again. However, it was not Van Baaren who took the initiative to establish a connection between the conservatory and the Boerman/Raaijmakers studio but Raaijmakers himself, encouraged by Van Baaren's student Misha Mengelberg, who had known Raaijmakers since their participation in the Mood Engineering Society concerts.<sup>446</sup>

Although Boerman and Raaijmakers had received a donation of f6,000 from Casimir in January 1964 (see Chapter 11, 231–46), their financial situation was still problematic. Their request for funding from the Prins Bernhardfonds (Prince Bernhard fund) was turned down in

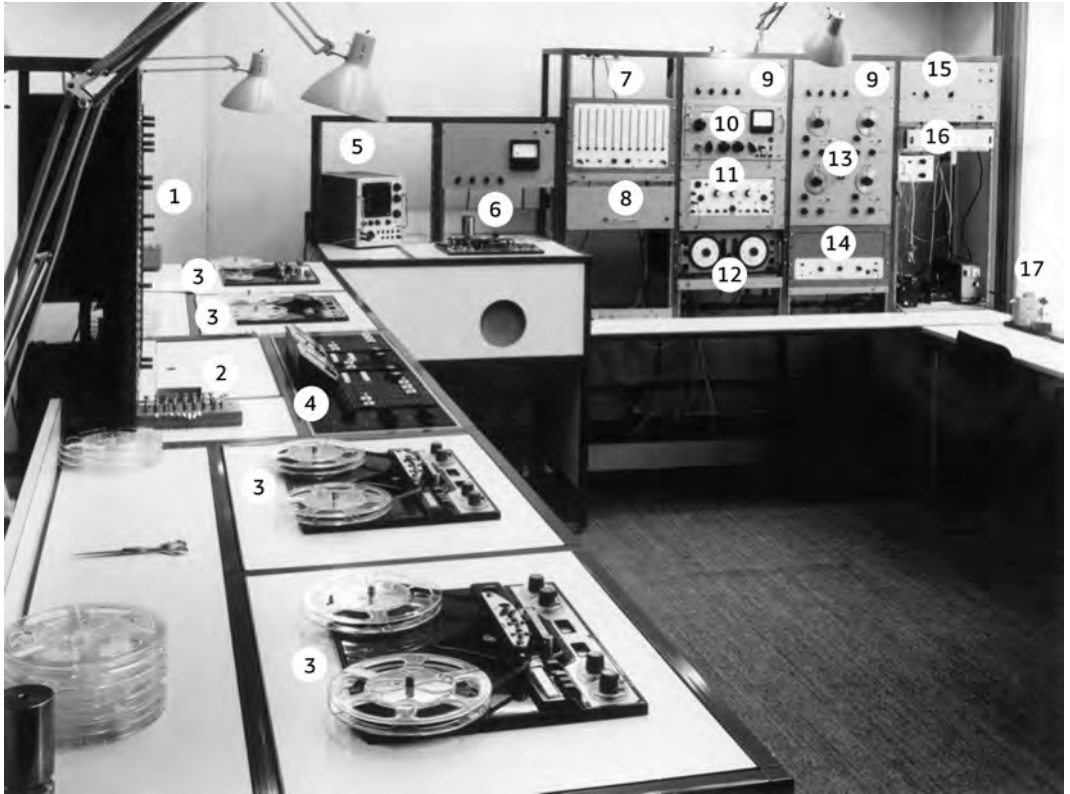

Fig. 3.36: Electronic music studio at the Royal Conservatoire, December 1966, with (1) patch field, (2) set of eleven shafts for variable tape speeds in chromatic steps, (3) four Revox G36 tape recorders, (4) custom-built mixing desk by W. Verschoor of TH Delft, (5) oscilloscope, (6) Revox G36 tape recorder modified by Verschoor for variable speed and “time translations” (see Chapter 11, 231–46), (7) Peekel TF824 multi-octave filter, (8) phonograph in pull-out tray, (9) power amplifiers, (10) Rode & Schwarz Abstimmbarer Anzeigeverstärker UBM, (11) Advance Instruments impulse generator, (12) Tonographie H83B impulse generator, (13) four Honor TE-22 sine / square wave generators, (14) Peekel 230R noise generator, (15) ring modulator built by Verschoor, (16) spring reverb, and (17) electric monochord built by Verschoor. Photo by Fons Hellebrekers.

November 1964.<sup>447</sup> A meeting was therefore arranged at STEM on March 8, 1965, between Van Baaren, Boerman, Raaijmakers, Koenig and De Vries, at which Raaijmakers again asked for financial support. All attendees agreed that besides the studios in Utrecht and Bilthoven, a studio was needed that could accommodate an educational program run by a conservatory. Van Baaren intended to create a position at the conservatory for Koenig to teach electronic music composition theory and wanted Raaijmakers and Boerman to handle the program’s practical aspects in their studio on Zuilingstraat in The Hague. Raaijmakers and Boerman were willing to put their studio at the disposal of the Royal Conservatoire on the condition that they were able to continue working on their own productions.<sup>448</sup>



The meeting in Utrecht was followed by more meetings between, respectively, Koenig and Raaijmakers (March 13 in Utrecht and March 23 in The Hague); Raaijmakers and Van Baaren (March 11 and April 8); Koenig, Raaijmakers and Van Baaren (April 15 in The Hague); and finally, Koenig and Raaijmakers again (April 26 in Utrecht).<sup>449</sup> As a result of these meetings, Van Baaren's plans changed considerably. Instead of a construction that would give his conservatory composition students access to Raaijmakers and Boerman's private studio, a design and budget were drawn up by Raaijmakers, Koenig and STEM technician Wim van Kuilenburg for a completely new studio at the Royal Conservatoire.<sup>450</sup>

Raaijmakers was designated as the studio manager, responsible for installing the equipment and for giving technical introductions to the students, who needed to be able to work on their own as soon as possible. The main difference between the Bilthoven studio and the conservatory studio was that the latter would facilitate the work of a very small number of students, each of whom would work several days per week for a long period, while the former had weekly slots of a few hours for a large number of course participants. Besides this practical work, Van Baaren intended eventually to ask Koenig to teach theoretical courses as part of the conservatory's curriculum for all interested students. He believed these courses might bring forward additional candidates for realizing compositions in the new studio.<sup>451</sup>

Van Baaren was ready to commission the studio construction work and order the necessary equipment in September 1965, and he hoped to have the studio ready by spring. Independently of the moment at which the studio opened its doors, he wanted Koenig to start giving lectures on electronic and computer music theory in The Hague at the beginning of the next academic year, in January 1966.<sup>452</sup> He also wished to coordinate activities with STEM. Raaijmakers was not appointed until September 1, 1966, however, and Koenig was never granted a position in The Hague.

In the meantime, Raaijmakers and Boerman had attended the German premiere of Stockhausen's *Mikrophonie I* at WDR in Cologne on June 11, 1965, at the invitation of Jaap Spek.<sup>453</sup> Spek had taken part in experiments in which Stockhausen excited a large tam-tam to vibration using a variety of objects held in one hand while scanning the tam-tam's surface with a highly directional microphone held in the other. The microphone was connected to a variable filter and a potentiometer, and Spek improvised with their settings. Stockhausen and Spek recorded their spontaneous actions on tape, and the recordings formed the basis for the score of *Mikrophonie I*, composed for two performers on tam-tam, two performers operating microphones, and two on filters and level controls.<sup>454</sup> Stockhausen's music had once again made a huge impression on Raaijmakers.

When the Royal Conservatoire officially opened its electronic music studio on April 27, 1967, Raaijmakers immediately had two students: Gilius van Bergeijk and Frans van Doorn (1930–1995). The studio's effect on the conservatory would turn out to be quite different from what Van Baaren had intended, however. According to Raaijmakers, Van Baaren had wanted to establish a studio for regular composition students where they could realize their



ideas using electronic means, i.e., produce tape compositions. Instead, Raaijmakers almost immediately took the equipment out of the studio and put it on stage to try out new ways of performing electronic music live.<sup>455</sup>

Van Baaren appointed his former student Van Vlijmen as assistant director in 1967, and soon after that, Van Baaren became seriously ill. Van Vlijmen had to take over all his responsibilities in May 1968. After Van Baaren died in September 1970, Van Vlijmen became the new director of the Royal Conservatoire.<sup>456</sup>

Raaijmakers later described the year 1967 as a turning point in his oeuvre:

I think that around that time, I realized that true composing – basing oneself on structures that are designed in advance and then imposed on the organization of sounds – was not my forte. [...] I had become aware of [...] other directions I could move in that would have more meaning for me. The first was to make explosive, almost ecstatic pieces – of which [1960's] *Pianoforte* is the first example. The second was exactly the opposite: the extremely methodological reduction of musical material until nothing remained but a series of electrical impulses and their organization – hence the *Canons*. A third direction, actually, is the demonstrative use of electronics. And this means you get up on stage and start doing things which no longer necessarily result in something autonomous, on tape, but something made exclusively for an audience in a room. And this this turned out to be the right direction for me.<sup>457</sup>

# Acknowledgments

In 2005, Stefan Weinzierl proposed to present my research in the form of a dissertation for the Technical University Berlin under his supervision. I thank him for his continuous support and advice throughout these years.

Jan de Heer has followed the process of writing closely. Our numerous, long and challenging discussions were crucial.

I want to thank Paul Berg for his frequent advice.

Writing this book would not have been possible without the generosity of Dick Raaijmakers and Gottfried Michael Koenig, who shared their correspondence, historical documents and memories with me. Our frequent conversations have been a source of inspiration, and I dedicate this book to them.

Peter Wever has supported my research on the Philips Pavilion intensively since we met in 2006. He made important contributions, and his efforts to trace no less than six former technicians of the Philips Pavilion have resulted in unique moments and a wealth of materials and technical details, especially coming from Paul Vancoppenolle, one of the pavilion's film operators.

Valuable information on the production of the music for the Philips Pavilion was given by the late Anton Buczynski.

I thank the late Rien Dissevelt-Reys and her son Ronald Dissevelt for trusting me with manuscripts and tapes of Tom Dissevelt's electronic compositions.

More insight into Raaijmakers' personal considerations between 1960 and 1965 was gained from his letters written to Miep Oddens-Roggen, which were kindly provided by her son Geert Oddens. Additional information came from Raaijmakers' letters to Jan Boerman written at the time of the establishment of their first private studio, which were found back by Marjanne Boerman just before this book was finished. My conversations with Jan and Marjanne Boerman have always been illuminating.

First-hand information from the years at STEM under Roelof Vermeulen and Henk Badings was given by Frits Weiland on several occasions. Weiland's dedication since 1960 to the analogue tape archive of STEM / the Institute of Sonology deserves to be mentioned here as well.

Jo Scherpenisse was helpful many times, explaining technical issues and logistics at the acoustics department of Philips Research Laboratories between 1956 and 1959.

Several other questions were answered during the writing of this book by Alex Balster, Paul Berg, Gilius van Bergeijk, Theo Boesveld, Marianne de Bruyn, Peter de Bruyn, Ton de Bruyn, Frits Cordess, Wilna Cordess, Wiel Cox, Huub Houët, Wim Langenhoff, Geoffrey Madge, Malcolm McDonald, Huub de Mul, Kees Nijssen, Paul Op de Coul, Jan Romijn, Boudewijn Tak and Chou Wen-chung.

Access to research materials was provided by Mark-Paul Meyer of the EYE Film Museum in Amsterdam, the Fondation Le Corbusier in Paris, the Institute of Sonology / Royal Conservatoire in The Hague, Heribert Henrich of the Musikarchiv Akademie der Künste in Berlin, the Nederlands Fotomuseum in Rotterdam, the Nederlands Jazz Archief in Amsterdam, Rik Hendriks and Frits Zwart of the Nederlands Muziek Instituut in The Hague, Felix Meyer of the Paul Sacher Stiftung in Basel, Lutgart Janssens De Cupere of Philips Belgium N.V. in Brussels, the Philips Company Archives in Eindhoven, Nathalie van Wilsem-Vos of Shell Nederland in The Hague and Hans van Keulen of the Theater Instituut Nederland in Amsterdam.

I thank Armin Kohlrausch of Philips Research and Marianka Louwers of Philips Company Archives for their efforts to trace original photographic material from *Philips Technical Review*.

I would like to thank Richard Barrett, Joke Brouwer, Johan van Kreijl, Arjen Mulder, Daniel Teruggi and Peter Wever for their careful reading of parts of this text and their valuable comments.

I consulted Richard Barrett on several occasions with questions concerning the English language. He also translated the introduction, which was written in Dutch at first.

I want to thank Henk van der Meulen for his support and the Royal Conservatoire for being flexible.

Last but not least, I want to thank Marianne Dekker for her constant help, her company and her patience.

Additional thanks go to Ronald Aarts, Ingrid Beirer, Justin Bennett, Lieven Bertels, Konrad Boehmer, Jeanne de Bont, Catharina Boon, Hannah Bosma, Lex van den Broek, Maria Buczynski, Peter van Dam, Raviv Ganchrow, Paul Jeukendrup, Nicolette Heerema, Jan Heijnen, Folkmar Hein, Willem Hering, Henk Heuvelmans, Joep Huiskamp, Sharon Kanach, Bert Kraaijpoel, Henk Lamers, Ariane de Leeuw, Vincenzo Lombardo, Peter Nuijten, Peter Pabon, Gabriel Paiuk, Kathinka Pasveer, Sara Pinheiro, Wijnand Plaizier, Adriaan Reinink, Wessel Reinink, Robert van Rixtel, Erwin Roebroeks, Frans de Ruiter, Joel Ryan, Jeroen van der Schaaf, Frank Scheffers, Casper Schipper, Hans Schipper, Piet Schreuders, Hanne Sons, Volker Straebel, Andrea Valle and Diemer de Vries.

# List of Illustrations

- Author's collection: 1.1, 1.4-5, 1.9, 1.59, 1.85, 1.87-89, 1.91-96, 1.98-101, 1.110-112, 2.3-4, 2.6-7, 2.30, 2.48-51, 2.59, 2.62-67, 2.69, 2.77, 2.86, 2.108-110, 3.3-4, 3.6, 3.8, 3.14-15, 3.17-22, 3.24-26, 3.29.
- Boerman, Jan. LP insert for *Composition 1972 / Alchemie 1961 / De Zee* (Amsterdam: Donemus, CV 7701): 3.30.
- Bruyn, Marianne de, private collection: 1.55, 2.43.
- De bouw van het Philipspaviljoen*, digital copy of 16 mm film, EYE Film Institute Netherlands: 2.31-36.
- Die magnetische Schallaufzeichnung in Theorie und Praxis* (special edition of the monthly magazine Radiotechnik/Radio-Amateur). Technischer Zeitschriftenverlag B. Erb, Wien (1952): 1.41.
- Fondation Le Corbusier: 2.37-42, 2.53-55, 2.87-88.
- Fuel for the Future*, video copy of 16 mm film, Institute of Sonology: 1.102-107.
- Gravesaner Blätter*: 1.48-49, 1.113.
- Haags Gemeentearchief: 3.23.
- Institute of Sonology: 1.84, 1.86, 1.90, 1.97, 2.44, 2.46, 3.9, 3.11-13, 3.31, 3.33-36.
- International Lighting Review*: 2.15, 2.21-27, 2.111.
- Kalff, Jan, private collection: 2.2.
- Leeuw, Ariane de, private collection: 3.1.
- Louis Kalff Materials: 2.72.
- Koenig, Gottfried Michael, private collection: 3.32.
- Meyer, Felix, and Heidi Zimmermann, eds. 2006. *Edgard Varèse: Composer, Sound Sculptor, Visionary*. Woodbridge, Suffolk: The Boydell Press: 2.47.
- Meyer-Eppler, Werner, ed. 1955. *Gravesano: Musik, Raumgestaltung, Elektroakustik*. Mainz: Ars viva Verlag: 1.51-52.
- Nationaal Archief / Spaarnestad Photo: 1.12.
- Nederlands Fotomuseum: 2.79-85.
- Netherlands Music Institute: 1.60, 1.108-109, 3.2, 3.16.
- Petit, Jean, ed. 1958. *Le poème électronique – Le Corbusier*. Paris: Les éditions de minuit: 2.76.
- Philips. 1954. *A Short Description of the Philips Factories in the Netherlands*. Philips: place of publication unknown: 2.46.
- Philips Belgium N.V.: 1.58-59, 1.61-63, 2.16-20, 2.28-29, 2.52, 2.57-58, 2.78, 2.91, 2.105-107, 2.112.
- Philips Company Archives: 1.7-8, 1.15-18, 1.24, 1.26, 1.30, 1.33, 1.38-40, 1.44-47, 1.53-54, 2.8-14, 2.45, 2.56, 2.70.
- Philips Technisch Tijdschrift*: 1.6, 1.10, 1.13, 1.20-23, 1.25, 1.27-29, 1.34, 1.36-37, 1.42, 1.56, 1.57, 2.71, 2.89-90, 3.28.
- Raaijmakers, Dick. 2005. *Cahier "M": A Brief Morphology of Electric Sound*. Trans. Richard Barrett. Leuven: University Press, Revised edition: 3.27.
- Rodenburg, Mariëtta, private collection: 1.2-3, 1.11, 1.14, 1.19, 1.31-32, 1.35, 1.43.
- Ryan, Kevin, and Brian Kehew. 2006. *Recording the Beatles*. Houston, Texas: Curvebender Publishing: 1.50.
- Sartory, Karel. 1941. *Im Dienste des Elektrons*. Philips: place of publication unknown: 2.5.
- Snel, D. A., 1958. *Magnetische geluidsregistratie*. Eindhoven: Philips technische bibliotheek: 2.92.
- Stockhausen Foundation for Music: 3.5.
- Theater Instituut Nederland: 3.7.
- Utrecht Archives: 3.10.
- Vancoppenolle, Paul. Digital copy of 8 mm film, Peter Wever / EYE Film Institute Netherlands: 2.93-104.
- Variations électroniques*, video copy of 16 mm film, Institute of Sonology: 1.78-83.
- Vries, Jan-Willem de. 2012. DVD accompanying *De Toonder Animatiefilms*. 's-Hertogenbosch: Silvester Strips uitgeverij b.v.: 1.64-77.
- Wilbrink, Frans, private collection: 2.1.

# Notes

## Introduction

1. Edgard Varèse, “The Liberation of Sound,” in *Contemporary Composers on Contemporary Music*, eds. Elliott Schwarz and Barney Childs (New York: Da Capo Press, 1998), 196.
2. Konrad Boehmer, “Pierre Schaeffer’s ‘Traité’” in Pierre Schaeffer, *Traktaat van de muzikale objecten* [Tract of the musical objects], trans. Konrad Boehmer (Ubbergen: Uitgeverij Tandem Felix, 2006), 17.
3. See for instance Koen Schouten, “Aha! Hier komt het allemaal vandaan” [Ah! this is where it all comes from], *de Volkskrant* (29 July 2004): 14 and Peter van Brummelen, “De opa van Tiësto” [The grandfather of Tiësto], *Het Parool* (31 August 2004): supplement, 10.
4. See for instance Peter Peters, *Eeuwige jeugd: Een halve eeuw Stichting Gaudeamus* (Amsterdam: Donemus, 1995).
5. Elena Ungeheuer, ed., *Elektroakustische Musik* (Laaber: Laaber-Verlag, 2002), 81.

## Part I

### Chapter 1

#### Developments in Electroacoustics at Philips before 1945

1. Marc J. de Vries, *80 Years of Research at the Philips Natuurkundig Laboratorium 1914–1994* (Amsterdam: Pallas Publications, 2005), 16.
2. Hendrik B. G. Casimir, *Het toeval van de werkelijkheid: Een halve eeuw natuurkunde* [The coincidence of reality: Half a century of physics] (Amsterdam: Meulenhoff Informatief, 1983), 272–73.
3. I. J. Blanken, *Geschiedenis van Philips Electronics N.V.: Een industriële wereldfederatie* [History of Philips Electronics N.V.: A global industrial federation] (Zaltbommel: Europese Bibliotheek, 2002), 123–25.
4. Letter from Kalff to Xenakis of July 4, 1957 (LKM).
5. I. J. Blanken, *Geschiedenis van Philips Electronics N.V.: De ontwikkeling van de N.V. Philips’ Gloeilampenfabrieken tot elektrotechnisch concern* [History of Philips Electronics N.V.: The development of N.V. Philips’ lightbulb factory into an electrotechnical concern] (Leiden: Martinus Nijhoff, 1992), 216–17.
6. *Ibid.*, 263–82. The Jaarbeurs Utrecht was held from September 6 to 15, 1927.
7. Kalff, who would later become Philips’ general art director, plays an important role in Part 2 as the animator of the Philips Pavilion project for the Brussels 1958 World’s Fair.
8. Blanken, *Geschiedenis van Philips Electronics N.V.: De ontwikkeling van de N.V. Philips*, 285.
9. Patent no. 22655 at the Octrooiraad Nederland [Dutch patent office].
10. Patent no. 28417 at the Octrooiraad Nederland.
11. Keith Geddes, *Broadcasting in Britain 1922–1972* (London: Her Majesty’s Stationary Office, 1972), 44.
12. J. J. Schurink, “De electro-dynamische dubbelconusluidspreker” [The electro-dynamic double-cone loudspeaker], *Philips Technisch Tijdschrift* 10 (1954).
13. The Philips 9710M double-cone loudspeaker is still sought after by audiophiles today.
14. De Vries, *80 Years of Research*, 41–2.
15. R. Vermeulen, “Muziek Centrum,” report for Philips Research Laboratories of June 20, 1945, PCA NL 315 Acoustiek.
16. Blanken, *Geschiedenis van Philips Electronics N.V.: De ontwikkeling van de N.V. Philips*, 330.
17. *Ibid.*, 349.
18. Between 1927 and 1930, the standard speed for sound film was set at 24 frames per second. According to the Kodak Film Calculator, at that rate, 300 meters of film equals a duration of 10 minutes and 56 seconds.
19. A technique developed by the Radio Corporation of America (RCA).
20. K. H. F. M. Dibbets, “Spreekende films: De komst van de geluidsfilm in Nederland 1928–1933” [Talking films: The rise of the sound film in the Netherlands, 1928–1933] (Ph.D. dissertation, University of Amsterdam, 1993), 54–55.
21. United Artists’ *The Woman Disputed*.
22. Blanken, *Geschiedenis van Philips Electronics N.V.: De ontwikkeling van de N.V. Philips*, 350–56.
23. Dibbets, “Spreekende films,” 69.
24. R. Vermeulen, “Machines voor de weergave van spreekende films” [Machines for the reproduction of talking films], reprint from *De Ingenieur* 49 (1930).
25. L. C. Kalff, W. Tak and S. L. de Bruin, “Verwezenlijking van het ‘Elektronisch Gedicht’ in het Philipspaviljoen op de Wereldtentoonstelling te Brussel” [Realization of the “Electronic Poem” in the Philips Pavilion at the World’s Fair

- in Brussels], *Philips Technisch Tijdschrift* 6/7 (1958): 164; the original Dutch term for electrical shaft is “elektrische as.” In the English edition of the same article (*Philips Technical Review* 2/3 (1958/59): 39), this is translated as “magslips.”
26. Dibbets, “Sprekende films,” 70.
  27. Sies W. Numann was born as Syze Wiltour Neumann.
  28. Hans Schoots, *Gevaarlijk leven: Een biografie van Joris Ivens* [Living dangerously: A biography of Joris Ivens] (Uitgeverij Hans Mets, 1995), 91.
  29. A room with highly reflective walls and long reverberation times.
  30. Strong resonance peaks at certain frequencies, depending on the dimensions of the room. See also R. Vermeulen, “Het onderzoek van luidsprekers” [Research on loudspeakers], *Philips Technisch Tijdschrift* 12 (1939).
  31. Lou Lichtveld, who would later become better known under his pseudonym, Albert Helman, was born in Suriname. He was an organist, composer, writer, journalist, music critic and Suriname politician.
  32. R. Vermeulen, “Reis naar Parijs 18–21 Mei 1931” [Journey to Paris, May 18–21, 1931], PCA NL 563, Sprekende film reisrapporten 1928–1938 [Talking film journey reports, 1928–1938]. In his report, Vermeulen wrote “Graetz” and “Leblanc,” but one can assume that he meant “Kretsch” and “Leblond.” A Kerr cell is an electro-optical device based on the Kerr effect and used as an optical shutter or light modulator. Kerr cells were used to record sound on the soundtrack of motion-picture film.
  33. Schoots, *Gevaarlijk leven*, 94.
  34. Blanken, *Geschiedenis van Philips Electronics N.V.: De ontwikkeling van de N.V. Philips*, 370.
  35. Review in newspaper *Het Volk*, September 29, 1931, quoted in Schoots, *Gevaarlijk leven*, 94.
  36. I. J. Blanken, *Geschiedenis van Philips Electronics N.V.: Onder Duits beheer* [History of Philips Electronics N.V.: Under German management] (Zaltbommel: Europese Bibliotheek, 1997), 77.
  37. *Ibid.*, 79–80, and R. Vermeulen, “Het Philips-Miller systeem voor geluidsregistratie” [The Philips-Miller system for sound recording], *Philips Technisch Tijdschrift* 4 (1936): 108.
  38. Blanken, *Geschiedenis van Philips Electronics N.V.: Onder Duits beheer*, 83; original source: “Een demonstratie van een Philips-Miller toestel te Parijs” [A demonstration of a Philips-Miller device in Paris], *Nieuwe Rotterdamse Courant* (March 1, 1936).
  39. Blanken, *Geschiedenis van Philips Electronics N.V.: Onder Duits beheer*, 85.
  40. M. J. C. van der Meulen, “Een wagen voor geluidsofname volgens het Philips-Miller systeem” [A van for sound recording using the Philips-Miller system], *Philips Technisch Tijdschrift* 3 (1939).
  41. Geddes, *Broadcasting in Britain*, 35.
  42. A famous surviving Philips-Miller recording is Willem Mengelberg’s performance of Johann Sebastian Bach’s *Matthäus Passion* with the Concertgebouw Orchestra, recorded at the Concertgebouw by the Nederlandsche Radio Unie on Palm Sunday, April 2, 1939. The 8,000 meters of Philips-Miller tape was found in 1952 and transferred to magnetic tape. The recording was released on the Philips record label in 1953 (A 00150 L – A 00153 L). It was later rereleased on the Naxos label (8.110880-82).
  43. Friedrich Engel, Gerhard Kuper and Frank Bell, *Zeitschichten: Magnetbandtechnik als Kulturträger* [Layers of time: Tape technology as a cultural medium] (Potsdam: Polzer Media Group GmbH, 2008), 152; original source: Edward Pawley, *BBC Engineering 1922–1972* (BBC Publications, 1972).
  44. K. de Boer and R. Vermeulen, “Een installatie voor een slechthoorende” [An installation for a hearing-impaired person], *Philips Technisch Tijdschrift* 11 (1939). Kornelis de Boer earned his doctorate in December 1940 with a dissertation on stereophonic sound reproduction.
  45. Both effects were later experimentally confirmed and termed “binaural masking level difference” and “binaural suppression of reverberance”; see: Nathaniel I. Durlach, “Binaural Signal Detection: Equalization and Cancellation Theory,” in *Foundations of Modern Auditory Theory, Volume 2*, ed. J. V. Tobias (New York: Academic Press, 1972).
  46. K. de Boer, “Proeven met stereofonoplaten” [Tests with stereophonic phonograph records], *Philips Technisch Tijdschrift* 6 (1940).
  47. Although this claim was repeated by De Boer in “Stereofonische geluidswaergave” (Ph.D. dissertation, Technische Hoogeschool Delft, 1940), 101, one can seriously doubt whether such an accuracy would have been possible with the signals from the artificial head reproduced on loudspeakers instead of headphones.
  48. K. de Boer, “Stereofonische registratie op Philips-Miller-film” [Stereophonic recording on Philips-Miller film], *Philips Technisch Tijdschrift* 3 (1941).
  49. The strong pulling force needed to overcome the resistance of both chisels caused the tape to stretch. Furthermore, this stretching was not constant, since the pulling force varied depending on the cutting depth of the chisels. During playback, this resulted in a variable delay between the left and right channels, disrupting the accuracy of the stereophonic image.
  50. C. J. Dippel and K. J. Keuning, “Problemen bij de fotografische reproductie, in het bijzonder van sprekende film” [Problems encountered in photographic reproduction, with sound film in particular] *Philips Technisch Tijdschrift* 3 (1947): 65–96. R. J. H. Alink, C. J. Dippel and K. J. Keuning, “Het metaal-diazonium-systeem voor fotografische reproductie” [The metal-diazonium-system for photographic reproduction], *Philips Technisch Tijdschrift* 10 (1947).
  51. Kees Boersma, *Inventing Structures for Industrial Research: A History of the Philips Nat. Lab, 1914–1946* (Amsterdam: Aksant Academic Publishers, 2002), 69–70.
  52. Although the foreword of *Philips Technical Review* of January 1946 states that the magazine did not appear from July 1942 to December 1945, issues definitely came out in July, August and September 1942.
  53. K. de Boer, “Stereofonische afbeelding” [Stereophonic imaging], *Philips Technisch Tijdschrift* 2 (1946).



54. Arend Schelp, "Radio-rubriek," *Mens en Melodie* 7 (1946): 221.
55. The BBC presumably carried out a similar experiment in 1925.
56. "Belangrijk radio-experiment: Vandaag stereofonische uitzending" [Important radio experiment: Stereophonic broadcast today], *Trouw* (June 15, 1946): 2. Translation by author; for original quote, see Appendix.
57. J. F. Schouten, "Synthetisch geluid," *Philips Technisch Tijdschrift* 6 (1939).
58. J. F. Schouten, "Lichtbuiging aan geluidsfilm" [Light deflection on sound film], *Philips Technisch Tijdschrift* 10 (1938).
59. The name "optical siren" was not used in the original 1939 publication but in H. Badings and J. W. de Bruyn, "Elektronische muziek" [Electronic music], *Philips Technisch Tijdschrift* 9 (1957): 275.
60. L. Blok, "Een toongenerator" [A tone generator], *Philips Technisch Tijdschrift* 9 (1940): 276.
61. To electrically generate low frequencies, one needs very large capacitors and coils. But here, instead of generating the sine wave directly within the audible range, two very high frequencies – one constant and one variable – are generated, for which the electric components needed are small. The frequency of the output of the tone generator is the difference tone of the two generated frequencies.
62. R. Vermeulen and J. de Boer, "Optische modellen ter bestudeering van de acoustiek van toneelzalen" [Optical models for studying the acoustics of theaters], *Philips Technisch Tijdschrift* 2 (1936): 49–50.
63. L. C. Kalff, *Kunstlicht en Architectuur* [Artificial lighting and architecture] (Amsterdam: Meulenhoff & Co. N.V., 1941), 209.
64. A photo of the event shows Vermeulen as a member of the orchestra.
65. R. Vermeulen, "Perspectieven voor een ontwikkeling van de viool" [Perspectives for development of the violin], *Philips Technisch Tijdschrift* 2 (1940): 41–2.
66. *Ibid.*, 45.
67. "Lab-violen voor muziekschool" [Lab violins for music school], *Philips Koerier* (23 January 1960): 8.
68. "In Memoriam," *Journal of the Audio Engineering Society*, vol. 19, no. 2 (1971): 180.

## Chapter 2 After World War II: Towards Electronic Music

69. R. Vermeulen, "Muziek Centrum," report for Philips Research Laboratories, June 20, 1945, PCA NL 315 Acoustiek rapporten. Translation by author; for original quote, see Appendix.
70. *Ibid.* Translation by author; for original quote, see Appendix.
71. During the Philadelphia-Washington experiment of April 27, 1933, supervised artistically by Stokowski and technically by the scientist Harvey Fletcher (1884–1981), three microphones were placed in front of the Philadelphia Symphony Orchestra and each connected to a loudspeaker in Constitution Hall in Washington through separate transmission lines. The frequency range was 40–15,000 Hz and the dynamic range 70 dB, and a very good reproduction of the spatial information was also achieved. K. de Boer, "Stereofonische geluidswaergave" [Stereophonic sound reproduction] (Ph.D. dissertation, Technische Hoogeschool Delft, 1940), 58.
72. R. Vermeulen, "Muziek Centrum." Translation by author; for original quote, see Appendix.
73. *Ibid.* See Translation by author; for original quote, see Appendix.
74. Leopold Stokowski, *Music for All of Us* (New York: Simon and Schuster, 1943).
75. The first reference in Vermeulen's journal to Stokowski's book appears on May 14, 1947.
76. Stokowski, *Music for All of Us*, 1–2.
77. *Ibid.*, 98.
78. Louise Varèse, *Varèse: A Looking-Glass Diary* (New York: W. W. Norton & Company Inc., 1972), 195–96.
79. Malcolm MacDonald, *Varèse: Astronomer in Sound* (London: Kahn & Averill, 2003), 135.
80. A theremin is an early electronic musical instrument controlled without discernible physical contact from the player. It is named after its Russian inventor Lev Termen (1896–1993), who patented it in 1928. According to MacDonald in *Varèse*, 268–69, Varèse commissioned Termen to build two instruments to his personal specifications for the premiere of *Ecuatorial*. Unlike the original theremin, this version possessed a keyboard.
81. An ondes Martenot is another early electronic instrument, invented in 1928 by the cellist Maurice Martenot (1898–1980). It is played with a keyboard but can also produce vibrato effects and glissandi.
82. Stokowski, *Music for All of Us*, 169–70.
83. The music for *Fantasia* consisted of J. S. Bach's Toccata and Fugue in D Minor (orchestrated by Stokowski), Tchaikovsky's *Nutcracker Suite*, Paul Dukas' *The Sorcerer's Apprentice*, Stravinsky's *The Rite of Spring*, Beethoven's Sixth Symphony, Amilcare Ponchielli's *Dance of the Hours*, Mussorgsky's *Night on the Bare Mountain* and Schubert's *Ave Maria*.
84. William E. Garity and Watson Jones, "Experiences in Road-Showing Walt Disney's *Fantasia*," *Journal of the Society of Motion Picture Engineers* (July 1942).
85. With the exception of Paul Dukas' *The Sorcerer's Apprentice* and Schubert's *Ave Maria*.
86. Garity and Jones, "Experiences."
87. William E. Garity and J. N. A. Hawkins, "Fantasound," *Journal of the Society of Motion Picture Engineers* (August 1941).
88. Philips would later use similar techniques in the automation of the *son et lumière* projects and the performance of *Le poème électronique* in the Philips Pavilion at the Brussels World's Fair of 1958.
89. Garity and Hawkins, "Fantasound." By the time of the premiere, the eight control tones were reduced again to three.

90. Boersma: *Inventing Structures*, 69–70.
91. Cycles per second, or hertz.
92. Apparently, Holst had reported to Stokowski on the possibilities of the Philips-Miller system and the artificial head microphone techniques described in Chapter 1, 26–33.
93. Letter from Stokowski to Holst of December 20, 1945, PCA NL 314 Acoustiek (correspondentie).
94. R. Vermeulen, *Dagboek* [Journal] 17, June 10, 1947, PCA NLwb 2850.
95. R. Vermeulen, *Dagboek* [Journal] 14, PCA NLwb 2280.
96. Letter from Holst to Stokowski of February 8, 1946, PCA NL 314 Acoustiek (correspondentie).
97. R. Vermeulen and W. K. Westmijze, “Het expressor-systeem voor muziekoverdracht” [The expressor system for musical transmission], *Philips Technisch Tijdschrift* 10 (1949).
98. R. Vermeulen, “Voorstel voor een programma acoustiek: 14 December 1946” (Proposal for an acoustics program: December 14, 1946), PCA NLwb 2669. “teneinde een leidraad te vormen en een verheldering van het inzicht te verkrijgen op punten waar thans op grond van intuïtie en geloof vaak veel geld besteed wordt aan misschien overbodige verbeteringen.”
99. Letter from Holst to Stokowski of January 27, 1947, PCA NL 314 Acoustiek (correspondentie).
100. “In Memoriam,” *Journal of the Audio Engineering Society*, vol. 19, no. 2 (1971): 180.
101. Letter from Vermeulen to Stokowski of March 10, 1947, PCA NL 314 Acoustiek (correspondentie).
102. Letter from Stokowski to Holst of March 19, 1947, PCA NL 314 Acoustiek (correspondentie).
103. See the last part of Chapter 1, 28–33.
104. Philips had developed a simple device for recording sound directly to disc in 1939. See K. de Boer and A. Th. van Urk, “Een eenvoudig toestel voor geluidsregistratie” [A simple device for sound recording], *Philips Technisch Tijdschrift* 4 (1939).
105. R. Vermeulen, *Dagboek* [Journal] 16, PCA NLwb 2669.
106. Letter from Stokowski to the Nederlandsche Concertdirectie, quoted in a letter from J. Beek to Vermeulen of March 24, 1947, PCA NL 314 Acoustiek (correspondentie).
107. *Ibid.*
108. R. Vermeulen, *Dagboek* 16, PCA NLwb 2669.
109. Blanken, *Geschiedenis van Philips Electronics N.V.: Een industriële wereldfederatie*, 68–9.
110. It is more likely, though, that this had to do with the listening positions of individual members of the audience.
111. Jaap van Ginneken (1913–1972) was a composer and the author of *Toekomstmuziek: Gedachten over de vernieuwing der muziek* [Music of the future: Thoughts on the modernization of music] (Rotterdam: W. L. & J. Brusse N.V., 1948).
112. M. J. C. van der Meulen, acting as chief mixer, made the recordings in Amsterdam.
113. R. Vermeulen, “Philips Stereophonic Recording Experiments with Mr. Leopold Stokowski in the Concertgebouw in Amsterdam,” 15 June 1947, attachment to *Dagboek* [Journal] 17, PCA NLwb 2850.
114. *Ibid.*
115. Vermeulen had previously expressed a wish to further investigate test results from the United States showing that the frequency range above 5,000 Hz should be left out of recordings. R. Vermeulen, “Voorstel voor een programma acoustiek: 14 December 1946” [Proposal for an acoustics program: December 14, 1946], PCA NLwb 2669.
116. R. Vermeulen, “Philips Stereophonic Recording Experiments with Mr. Leopold Stokowski in the Concertgebouw in Amsterdam,” June 15, 1947, attachment to *dagboek* [Journal] 17, PCA NLwb 2850.
117. Edgar Varèse, *Music as an Art-Science*, lecture given at the University of Southern California in 1939, quoted in Chou Wen-chung, ed., “The Liberation of Sound (Excerpts from lectures by Varèse),” *Perspectives of New Music* Vol. 5 no. 1 (1966): 13.
118. R. Vermeulen: “Space in Music,” typescript of February 23, 1959, place of publication unknown, Institute of Sonology archive.
119. Letter of Vermeulen to Stokowski of January 26, 1948, PCA NL 314 Acoustiek (correspondentie).
120. R. Vermeulen, “*Dagboek* 19. America. 18 April 1948 t/m 22 Juni 1948,” PCA NLwb 3078. This was probably the first time Vermeulen had heard of the ondes Martenot. In 1957, he sent Dick Raaijmakers to Paris to receive instructions for playing the instrument and to order one for the Philips Research Laboratories electronic music studio in Eindhoven.
121. R. Vermeulen, “Multiplicatie van concerten,” *Philips Technisch Tijdschrift* 6 (1948): 167.
122. *Ibid.*, 168. “er zal aan deze mensen ook toegang verschaft moeten worden tot de domeinen van de geest.”
123. *Ibid.*, 174. “Is het aanschouwen van een verzameling zwoegende musici werkelijk de meest geschikte ondersteuning voor de muzikale genieting?”
124. *Ibid.*
125. Beethoven’s *Pastorale*, or Sixth Symphony, is used in Walt Disney’s *Fantasia*. In fact, the images that accompany it are some of the most figurative in the film. On the other hand, there are moments during Bach’s Toccata and Fugue and Stravinsky’s *The Rite of Spring* when the visuals are indeed dominated by abstract patterns and colors. Stokowski appears to have confused these scenes.
126. R. Vermeulen, *Dagboek* 19. “America. 18 April 1948 t/m 22 Juni 1948,” PCA NLwb 3078. “ook alleen maar een technisch element.”
127. Vermeulen, “Multiplicatie,” 174.
128. *Ibid.*, 171–72.

129. Ibid., 175. “Met deze toekomstmuziek, in letterlijke zin, mogen we deze beschouwingen besluiten.”
130. L. Alons wrote the article “Nieuwe ontwikkelingen op grammofoongebied” [New developments in the gramophone field], *Philips Technisch Tijdschrift* 4 (1951).
131. R. Vermeulen, *Dagboek* [Journal] 17, 10 June 1947. PCA NLwb 2850. “kan dus alleen door een musicus beoordeeld worden.”
132. Ibid.
133. Ibid.
134. R. Vermeulen: “Space in Music,” typescript of February 23, 1959, place of publication unknown; Institute of Sonology archive.
135. Vermeulen and De Boer, “Optische Modellen,” 49–50.
136. Arno Weltens, Rob Marx, Arie den Dikken and Max Cramer, *Kathedralen en Luchtkastelen van de Omroep in Hilversum* [Cathedrals and castles in the air in Hilversum broadcasting] (Zwolle, Waanders Uitgevers, 2002), 46–7.
137. A. Th. van Urk, “Zaalacoustiek en nagalm,” *Philips Technisch Tijdschrift* 3 (1938).
138. R. Vermeulen, “Zaalacoustiek en verstaanbaarheid,” *Philips Technisch Tijdschrift* 5 (1938).
139. R. Vermeulen, “Zaalacoustiek en geluidsabsorptie,” *Philips Technisch Tijdschrift* 12 (1938).
140. Willem Tak left Philips Research Laboratories directly after World War II and moved to Philips ELA. He played an important role in designing the electroacoustic installation for the Philips Pavilion in 1956–1958.
141. W. Tak, “Nagalmmeting” [Measuring reverberation], *Philips Technisch Tijdschrift* 3 (1946).
142. W. Tak, “Het meten van de nagalmtijd volgens de methode met exponentieel aangroeiende versterking” [Measurement of reverberation time according to the method of exponentially increasing amplification], *Philips Technisch Tijdschrift* 12 (1947).
143. R. Vermeulen, “Voorstel voor een programma acoustiek: 14 December 1946” [Proposal for an acoustics program: December 14, 1946], PCA NLwb 2669.
144. Reverberation decays exponentially. To achieve good visualization on the oscilloscope, the signal from the microphone was amplified with an exponential increase over time after the end of each sound impulse. When the timing of the increase matched that of the reverberation, the response from the room appeared on the oscilloscope with a constant energy.
145. R. Vermeulen, “Stereonagalm” [Stereo reverberation], *Philips Technisch Tijdschrift* 7–8 (1955): 223.
146. Ibid., 224.
147. D. A. Snel, “Toestellen voor magnetische geluidsregistratie” [Devices for magnetic sound recording], *Philips Technisch Tijdschrift* 6 (1952).
148. Engel, Kuper and Bell, *Zeitschichten*, 295 and 232.
149. Ibid., 53.
150. Stokowski: *Music for All of Us*, 98.
151. R. Vermeulen, “Stereo-Reverberation,” *Journal of the Audio Engineering Society*, vol. 6, no. 2 (1958): 124.
152. Vermeulen, “Stereonagalm,” 224–28.
153. Frans Zuurveen, “Van radiolamp naar Compact Disc: En verder” [From radio bulb to Compact Disc: And beyond], in *Eindhoven Muziekstad*, eds. Jan van Oorschot and Frans Krämer (Hapert/Eindhoven: Kempen Pers bv, 1992), 141.
154. Vermeulen, “Stereonagalm,” 231.
155. D. Kleis, “Moderne geluidstechniek II: Elektro-akoestische voorzieningen in grote theaters” [Modern sound engineering II: Electroacoustic facilities in large theaters], *Philips Technisch Tijdschrift* 2–3 (1959): 64.
156. Zuurveen, “Van radiolamp naar Compact Disc,” 141.
157. H. Petzoldt, “A Time Delay Unit for Continuous Operation,” *Gravesaner Blätter* XI/XII (1958).
158. Kevin Ryan and Brian Kehew, *Recording the Beatles* (Houston, Texas: Curvebender Publishing, 2006), 306–9.
159. Hermann Scherchen, *Aus meinem Leben: Rußland in jenen Jahren* [From my life: Russia in those years] (Berlin: Henschelverlag Kunst und Gesellschaft, 1984), 60–66.
160. Ibid.
161. Werner Meyer-Eppler (1913–1960) had founded an electronic music studio with Robert Beyer at Nordwestdeutscher Rundfunk in 1951.
162. The trautionium is an electronic keyboard instrument invented by Friedrich Trautwein around 1929.
163. R. Vermeulen, “Music and Electroacoustics, Lecture with Demonstrations,” *Gravesano*, August 8, 1959; manuscript, Institute of Sonology archive.
164. Werner Meyer-Eppler, ed., *Gravesano: Musik – Raumgestaltung – Elektroakustik* (Mainz: Arsviva Verlag, 1955).
165. In his 1948 article about concert multiplication, Vermeulen had described an upper limit of 8,000 Hz as being sufficient.
166. Meyer-Eppler, ed., *Gravesano*, 132.
167. Ibid., 136.
168. Ibid., 138.
169. Dijksterhuis became technical manager of Philips’ Phonographic Industries in 1950. He retired in late 1957 for health reasons but continued to work on the electronic piano for Philips. He died in 1967. The instrument was finished after his death by T. Verhey and presented to the public on March 1, 1969.
170. R. Vermeulen, *Dagboek* [Journal] 14, PCA NLwb 2280.
171. The Philicord electronic clavichord should not be confused with the 1960s Philicorda electronic organ.
172. R. Vermeulen, *Dagboek* [Journal] 14, PCA NLwb 2280.

173. R. Vermeulen, "Voorstel voor een programma acoustiek: 14 December 1946," PCA NLwb 2669.  
 174. R. Vermeulen, Dagboek [Journal] 17, PCA NLwb 2850.  
 175. A recording was made, of which a cassette copy still exists in the collection of Kees Teer, Vermeulen's successor.  
 176. G. Remedi, "Kermis der Wetenschap" [Fair of science], *Philips Technisch Tijdschrift* 2 (1956): 63–4.

### Chapter 3 The Studio at Philips Research Laboratories

177. Leo Samama, *Zeventig jaar Nederlandse muziek 1915–1985* [Seventy years of Dutch music 1915–1985] (Amsterdam: E.M. Querido's uitgeverij B.V., 1986), 138.  
 178. Marius Monnikendam, *Nederlandse componisten van heden en verleden* [Dutch composers of the present and the past] (Amsterdam: A. J. G. Strengholt N.V., 1968), 153.  
 179. Henk Badings, *De hedendaagsche Nederlandsche muziek* [Contemporary Dutch music] (Amsterdam: Bigot en Van Rossum, 1936), 9. "wier gehele kunst bestaat uit het bijeenbrengen van 'nieuwe' klanken."  
 180. *Ibid.*, 14. "te veel eer bewezen aan de slopers van het reeds zeer wankele gebouw der monotonaliteit."  
 181. *Ibid.*, 74. "onbewoonbare revolutie-bouwsels"  
 182. *Ibid.*, 91. "het is van twaalftoontechnieksmetten vrij."  
 183. Interview with Henk Badings by Jos Leussink on May 15, 1974, quoted in Jos Leussink, "Orestes; radiofonische opera van H. Badings: Een muziekhistorische plaatsbepaling" [Orestes; radiophonic opera by H. Badings: A music-historical orientation] (thesis, Utrecht University, 1974), 30.  
 184. Henk Badings, "Electronic Music: Its Developments in the Netherlands," typescript of an article for *Philips Topics* 61 (1958): 4. Unfortunately, no recording of the work has been found as of the time of writing.  
 185. Ludy Kullberg, "Naar een radiofonische kunstvorm" [Towards a radiophonic art form], *Mens en Melodie* 11 (1954): 343. Original reference is the weekly *N.I.R.F. magazine*, Brussels, October 31, 1954.  
 186. A more extensive description of these radiophonic effects and how they were created can be found in Leussink, "Orestes."  
 187. Henk Badings and Arie Brandon, "Concrete, Electronische en Radiofonische Muziek" [Concrete, electronic and radiophonic music], *Radio Electronica* 3 (1956): 145.  
 188. Samama, *Zeventig jaar Nederlandse muziek*, 147. The original production of *Orestes* was in Dutch. Presumably, the BBC's version was in English, which would have made it more intelligible for a global audience.  
 189. R. Vermeulen, "Muziekcentrum," report for Philips Research Laboratories, June 20, 1945, PCA NL 315 Acoustiek (rapporten). Translation by author; for original quote, Translation by author; for original quote, see Appendix.  
 190. Interview with Dick Raaijmakers by the author, The Hague, September 1, 2008; digital recording.  
 191. J. W. de Bruyn, "Verslag betreffende de realisatie van de elektronische muziek bij het ballet *Kain en Abel* van ir. H. Badings" [Report on the production of electronic music for the *Kain en Abel* by H. Badings], (Eindhoven: Natuurkundig Laboratorium der N.V. Philips' Gloeilampenfabrieken, verslag nr. 3204, 17 August 1956), 2–4; author's collection.  
 192. De Bruyn, "Verslag," 3.  
 193. *Ibid.*, 5. Badings obviously borrowed the term "Klangfarbenmelodie" from Arnold Schoenberg, despite his aversion to Schoenberg's twelve-tone technique and modernist music in general. Schoenberg introduced the term in the closing sentence of his book *Harmonielehre* (Leipzig–Wien: Universal Edition, 1911), 471: "Klangfarbenmelodien! Welche feinen Sinne, die hier unterscheiden, welcher hochentwickelte Geist, der an so subtilen Dingen Vergnügen finden mag!" [Sound-color melodies! What fine senses distinguish themselves here, what sophisticated spirits may find joy in such subtle pleasure!] A famous example of a sound-color melody is the third part of Schoenberg's *Fünf Orchesterstücke*, op. 16 (1909).  
 194. *Ibid.*, 3.  
 195. See for instance: Karlheinz Stockhausen, *Nr. 12 – Kontakte – Elektronische Musik – Realisationspartitur* (London: Universal Edition, 1968). Gottfried Michael Koenig recalled that these filters were not used before 1958.  
 196. De Bruyn, "Verslag," 7.  
 197. The 10039 tape recorders were referred to as "Viennese" at Philips' Eindhoven site because they had been developed at the company's Vienna location. They were called "portable" because the line amplifier and tape transport were housed in separate cases. Still, the total weight of a complete unit was over 80 kg. Philips ELA soon offered the 10039 in a slightly altered form as EL3505, EL3507 and EL3509. The same type of machine would later be used in the production of *Le poème électronique* and in the studio at Technische Hogeschool Delft, the CEM studio in Bilthoven, and the STEM studios in Utrecht.  
 198. De Bruyn, "Verslag," 4.  
 199. Jo Scherpenisse, e-mail to author, December 30, 2009.  
 200. Personal note by Badings in a production list of Dutch electronic musical works, Netherlands Music Institute.  
 201. R. Vermeulen, "Space in Music," typescript, February 23, 1959, place of publication unknown; Institute of Sonology archive.  
 202. De Bruyn, "Verslag," 9.  
 203. The ballet was choreographed by Jan Zielstra (1921–2015). The main performers were Willy de la Bije, Toer van Schayk (\*1936), Jaap Flier (\*1934) and Aart Verstegen (1920–1998) (original program booklet, Holland Festival 1956; author's collection).  
 204. De Bruyn, "Verslag," 9.

205. Ibid.
206. WDR Hauptabteilung Musik, *Zwanzig Jahre Musik im Westdeutscher Rundfunk* [Twenty years of music at Westdeutscher Rundfunk] (Cologne: Westdeutscher Rundfunk Köln, 1968), 103. Other compositions on the program were Bengt Hambreus' *Doppelrohr II*, Hermann Heiß's *Elektronische Komposition I*, Giselher Klebe's *Interferenzen*, Herbert Eimert's *Fünf Stücke* and Ernst Krenek's *Spiritus Intelligentiae Sanctus*.
207. Wouter Paap, "Elektronische Muziek" [Electronic music], *Mens en Melodie* 9 (1956): 270–71.
208. The Vereeniging van Arbeiders Radio Amateurs [Workers' radio amateurs association] was renamed Omroepvereniging VARA in 1957.
209. Between 1934 and 1939, the Pal Studio made eleven films commissioned by Philips, with titles such as *In Lamp Light Land* (1935), *Ether Symphony* (1936), *The Philips Broadcast 1938* (1937), *The Ballet of Red Radio Valves* (1938), *Aladdin and the Magic Lamp* (1939) and *Philips Cavalcade* (1939).
210. Ole Schepp and Fred Kamphuis, *George Pal in Holland 1934–1939* (The Hague: Holland Animation, 1983), 9–11.
211. Ibid., 31–2.
212. Ibid., 14.
213. Jan-Willem de Vries, *De Toonder Animatiefilms* [The Toonder animated films] ('s-Hertogenbosch: Silvester Strips uitgeverij b.v., 2012), 30–1, 43.
214. Ibid., 72–90.
215. *Floepedorus, de flessengeest* [Floepedorus the genie] (1949), *Plucky Panda's Penny* (1949) and *The Legend of Loch Ness* (1950). To some extent, *Floepedorus* can be described as a commercial for Philips vacuum cleaners.
216. De Vries, *De Toonder Animatiefilms*, 306.
217. Blanken, *Geschiedenis van Philips Electronics N.V.: Een industriële wereldfederatie*, 31.
218. Huub Wijffjes, *Hallo Hier Hilversum! Driekwart eeuw radio en televisie* [Hello, this is Hilversum! 75 years of radio and television] (Weesp: Unieboek bv, 1985), 66–69.
219. A digital copy of *The Conquered Planet* was made available by EYE Film Institute Netherlands and also appears on the DVD accompanying De Vries' book *De Toonder Animatiefilms*.
220. De Vries, *De Toonder Animatiefilms*, 155.
221. When Van Gelder made the film *Paleontologie* at Toonder Studios for Royal Dutch Shell in 1958–1959, he used music composed by Jan Masséus that was electronic during the tabletop animation part (see Chapter 9, 192–97).
222. De Vries, *De Toonder Animatiefilms*, 155–57.
223. Badings' score and Brumsteede and Raucamp's storyboard for *Variations électroniques* are kept in the Netherlands Music Institute's Badings collection.
224. Interview with Dick Raaijmakers by the author, The Hague, September 1, 2008; digital recording.
225. Kees Tazelaar, "The Loudspeaker Speaks," trans. Richard Barrett, in *Witteveen+Bos-Prijzen voor Kunst+Techniek 2011: Dick Raaijmakers* (Deventer: Witteveen+Bos, 2011), 14–5.
226. Interview with Dick Raaijmakers by the author, The Hague, August 18 and 20, 2011; digital recording.
227. In conversations with the author, Raaijmakers frequently referred to "Night Train Blues" as a "tearjerker."
228. The name "Kid Baltan" was created by reversing Raaijmakers' nickname "Natlab Di(c)k," meaning "Dick from the Natuurkundig Laboratorium."
229. R. Vermeulen, "Muziekcentrum," report for Philips Research Laboratories of June 20, 1945, PCA NL 315 Acoustiek (rapporten). "Voor de 'canned music' der toekomst zouden de auteursrechten geen onoverkomelijk bezwaar meer vormen."
230. R. Vermeulen, "Baltan-plaatje" [Baltan record], May 9, 1958, PCA NL wb5416, besprekingen [discussions] 1956–1959.
231. "Lied van de tweede maan klonk via PhiBO: Elektronische muziek doet haar intrede in de amusementsector" [Song of the second moon played on PhiBO: electronic music enters the entertainment industry], *Philips Koerier* (October 26, 1957).
232. Kenneth Alford was the pseudonym of Fredrick Joseph Ricketts (1881–1945).
233. Interview with Dick Raaijmakers by the author, The Hague, September 1, 2008; digital recording.
234. Letter from Vermeulen to Ussachevsky of March 12, 1959, PCA NL 211 akoest. en opt. correspondentie.
235. R. Vermeulen, "Gartsen & Van Dongen," June 25, 1958, PCA NL wb5416, besprekingen [discussions] 1956–1959.
236. Philips GP 08010.
237. Herbert Eimert, *Lehrbuch der Zwölftechnik* (Wiesbaden: Breitkopf & Hartel, 1952).
238. Hanns Jelinek, *Anleitung zur Zwölftonkomposition* (Wien: Universal-Edition, 1952).
239. For more biographical information on Dissevelt, see: *Popular Electronics: Early Dutch Electronic Music from Philips Research Laboratories*, Basta Music 30.9141.2 (2004).
240. The compositions Dissevelt made at Philips Research were officially released as "produced by Tom Dissevelt and Kid Baltan."
241. R. Vermeulen, "Dissevelt – Van Dongen – Raaijmakers," November 27, 1958, PCA NL wb5416, besprekingen [discussions] 1956–1959.
242. The television program featuring Dissevelt and Raaijmakers at the Philips Research Laboratories electronic music studio was broadcast on January 17, 1959.
243. Marcel Joray, ed., *Nicolas Schöffer* (Neuchâtel: Éditions du Griffon, 1963), 50.
244. Ibid., 46.
245. Ibid., 50–7.

246. F. A. Loescher, "Technical Aspects at the Fifth Anniversary of Gravesano," *Gravesaner Blätter* XV/XVI (1960): 12.
247. R. Vermeulen, "Music and Electroacoustics: Lecture with Demonstrations," Gravesano, August 8, 1959; manuscript, Institute of Sonology archive.
248. Loescher, "Technical Aspects," 12.
249. *Ibid.*, 12–3.
250. *Ibid.*, 14.
251. *Ibid.*, and James Harley, *Xenakis: His Life in Music* (New York and London: Routledge, 2004), 23. Granular synthesis was first suggested as a computer music technique for producing complex sounds by Xenakis (1971) and Curtis Roads (1978) and is based on the production of a high density of small acoustic events called "grains," each less than 50 ms in duration. Typical grain densities range from several hundred to several thousand grains per second (Barry Truax, "Granular Synthesis," <http://www.sfu.ca/~truax/gran.html>; accessed February 12, 2013).
252. Loescher, "Technical Aspects," 14–5.
253. Vermeulen's list of electronic music productions in the Netherlands says Badings' *Elektromagnetische Klankfiguren* was commissioned by Scherchen. However, in a July 21, 1959, letter to Scherchen, Badings proposed contributing the already finished piece for the Gravesano celebration. Badings collection, Netherlands Music Institute.
254. List of electronic music productions in the Netherlands, Institute of Sonology archive.
255. A preliminary program listing the events in Gravesano in a different order was found in Dick Raaijmakers' archive. However, since Loescher's article contains a detailed eyewitness account that was published afterwards, it has been used here as a reference.
256. R. Vermeulen, "Gartsen & Van Dongen," June 25, 1958, PCA NLwb 5416, besprekingen [discussions] 1956–1959.
257. Other early Dutch serial compositions are *Sette aforismi* for chamber orchestra (1956) and *Cristalli* for two pianos (1958) by Jan Wissé.
258. Ton de Leeuw, *Experimentele Muziek: Een lezingenreeks in het seizoen 1957–'58 voor de A.V.R.O. microfoon* [Experimental music: A lecture series in the 1957–58 season for the A.V.R.O. microphone] (Hilversum: Algemene Vereniging Radio Omroep, 1958).
259. Interview with Dick Raaijmakers by the author, The Hague, May 5, 2009; digital recording.
260. Jessica Voeten, *Een Nederlands wonder: Vijftig jaar Holland Festival* [A Dutch miracle: Fifty years of the Holland Festival] (Amsterdam: Walburg pers / Stichting Holland Festival, 1997), 172.
261. Printed program notes for the premiere of De Leeuw's *Antiphonie*, Holland Festival, June 18, 1960. Translation by author; for original quote, see Appendix.
262. Raaijmakers' student records, Royal Conservatoire, The Hague.
263. In 1970, Raaijmakers decided to destroy every one of these manuscripts.
264. Interview with Dick Raaijmakers by the author, The Hague, May 5, 2009; digital recording.
265. B. F. Raaijmakers, "Reisrapport" [Travel report] for Philips Research Laboratories, November 11, 1958, PCA NL 211 (reisrapporten). Translation by author; for original quote, see Appendix.
266. Letter from the mayor of Eindhoven to Dick Raaijmakers, December 4, 1959, Netherlands Music Institute collection.
267. CD booklet for *The Complete Tape Music of Dick Raaijmakers*, CV-NEAR 09/10/11, 24–8.
268. Philips 835 056 AY.
269. Epic BC 1118 (Stereorama) and LC 3759 (mono).
270. Letter from Victor Di Bello to Dick Raaijmakers, October 12, 1963; Netherlands Music Institute collection.
271. Letter from Victor Di Bello to Dick Raaijmakers, November 23, 1963; Netherlands Music Institute collection.
272. Letter from Dick Raaijmakers to Victor Di Bello, December 11, 1963; Netherlands Music Institute collection.
273. From 1961 to 1964, the Stratford Shakespearean Festival's music directors were Glenn Gould, the cellist Leonard Rose (1918–1984) and the violinist Oscar Shumsky (1917–2000).
274. Glenn Gould, *Dialogues on the Prospects of Recording*, broadcast on CBC Radio, Canada, January 10, 1965.
275. Interview with Dick Raaijmakers by the author, The Hague, May 5, 2009; digital recording.
276. The cardioid-shaped response pattern reduces sensitivity to sounds coming from behind and at the sides of the microphone.
277. Badings' last work produced at Philips Research Laboratories with Raaijmakers' assistance, also in May 1960, was Act III, Scene 1 of the opera *Martin Korda D.P.*
278. Interview with Dick Raaijmakers by the author, The Hague, May 5, 2009; digital recording.
279. *Achter de schermen* literally translates as "behind the screens" and is used figuratively in the same way "behind the scenes" is in English.
280. Dick Horne (also known as Dick Horn) later worked on the animation for the Beatles' *Yellow Submarine* movie (1968).
281. Interview with Kees Teer by Henk Lamers, Eindhoven, December 15, 2005; video recording.
282. R. Vermeulen, "Muziekcentrum," report for Philips Research Laboratories, June 20, 1945, PCA NL 315 Acoustiek (rapporten). Translation by author; for original quote, see Appendix.
283. Interview with Kees Teer by Henk Lamers, Eindhoven, December 15, 2005; video recording.
284. *Ibid.*
285. R. Vermeulen, "Music and Electroacoustics: Lecture with Demonstrations," Gravesano, August 8, 1959; manuscript, Institute of Sonology archive.



286. Ibid.
287. Ibid.
288. Ibid.
289. Letter from Vermeulen to Escher of 30 January 1959, Escher collection, Netherlands Music Institute.
290. Vermeulen, "Music and Electroacoustics."
291. Minutes of the CEM assembly of March 16, 1959; author's collection.
292. Minutes of the CEM assembly of September 30, 1959; author's collection.
293. Minutes of the CEM assembly of March 21, 1960; author's collection.

## Part II

### Chapter 4

#### Preliminary Technical and Artistic Outline

1. Philips advertisement in *Gravesaner Blätter* XV/XVI (1960): 175.
2. F. A. Loescher, "Technical Aspects at the Fifth Anniversary of Gravesano," *Gravesaner Blätter* XV/XVI (1960): 12.
3. Comparing this list with a later version by Vermeulen, one can conclude it was made in August 1959, just after the Gravesano event on August 8.
4. See for instance: Peter Manning, *Electronic and Computer Music* (Oxford University Press, 2004), 82, or Malcolm MacDonald, *Varèse: Astronomer in Sound* (London: Kahn & Averill, 2003), 370–71.
5. Peter Wever, "Le Corbusier versus de Nederlandse architecten" [Le Corbusier vs. the Dutch architects], in *Dichtbij klopt het hart der wereld* [The world's heart beats nearby], ed. André Koch (Schiedam: Scriptum Art Publishers, 2008), 113.
6. Peter van Dam, *Ir. Louis C. Kalff: Het artistieke geweten van Philips* [Louis C. Kalff: Philips' artistic conscience] (Eindhoven: [Z]OO producties, 2006), 21.
7. An additional Philips Pavilion, at the 1955 Brasilia exposition, is mentioned in Marc Treib, *Space Calculated in Seconds* (New Jersey: Princeton University Press, 1996), 10. He cites the unverifiable source "Various files, Philips." A Philips Pavilion for a World's Fair in Brasilia dated 1953 is mentioned in Van Dam, *Ir. Louis C. Kalff*, 77. However, this World's Fair never took place; in fact, the city of Brasilia was only built in the late 1950s. The only World's Fair that ever took place in Brazil was held in 1922–1923.
8. Van Dam, *Ir. Louis C. Kalff*, 54.
9. Quoted in: Bart Lootsma, "Een ode van Philips aan de vooruitgang" [Philips' ode to progress], *Wonen-TABK 2* (1984): 10–1.
10. It has been suggested that this building later gave Kalff the idea for the design of the Evoluon, which combined a Philips museum, a demonstration laboratory and the ELA studio in one center (he made the first plans in 1960, and it opened in 1966). The Evoluon eventually became a museum showing the development of modern technology through elementary phenomena of physical science. See: Van Dam, *Ir. Louis C. Kalff*, 85–7.
11. The 1851 Great Exhibition in London was the first-ever World's Fair.
12. Van Dam, *Ir. Louis C. Kalff*, 68.
13. <http://www.hendrikwiegersma.com/biografie/ossip-zadkine>; accessed February 11, 2013.
14. The Museum Boijmans has been known as the Museum Boijmans Van Beuningen since 1958.
15. The film is available on the DVD *Classical Music in the Forties* (Wickford: Beulah, 2005).
16. W. Tak, "Het elektronisch gedicht: De geluidseffecten" [The electronic poem: The sound effects], *Philips Technisch Tijdschrift* 6/7 (1958): 167.
17. Philips, Afdeling electro-acoustiek, "Een demonstratiezaal voor het registreren en weergeven van geluid en voor filmprojectie" [A demonstration hall for sound recording and reproduction and film projection], *Philips Technisch Tijdschrift* 7 (1948).
18. Boudewijn Tak, e-mail message to author, September 1, 2012.
19. L. C. Kalff and W. Tak, "Multi-Use Ceilings," *International Lighting Review* 6 (1954).
20. *The ELAgraph*, vol. 4, no. 1 (1958): 1.
21. Ibid.
22. Ibid., 1–2.
23. Telegram from Kalff to Le Corbusier, October 10, 1956; LKM.
24. Edgard Varèse, "The Liberation of Sound," in *Contemporary Composers on Contemporary Music*, eds. Elliott Schwarz and Barney Childs (New York: Da Capo Press, 1998), 206.
25. *Spectacle son et lumière / Sound and Light Spectacular* (Philips brochure), early 1960s.
26. L. F. Siellet, M. Dénibéré, L. Gaymard and G. Leblanc, "Light and Sound Bring to Life the Monuments of France," *International Lighting Review* 1 (1955): 17–8.
27. *Illuminations en France*, Michelin map no. 251 (1952–1953).
28. *The ELAgraph* 4 (1958): 2.
29. Siellet, Dénibéré, Gaymard and Leblanc, "Light and Sound," *International Lighting Review* 1 (1955): 22.
30. Ibid.
31. André Castelot, "Athenian Enchantment," *International Lighting Review* 4 (1959): 139.
32. J. Delauné, "Robot Guide Installation at 'La Bénédicte,' Fécamp," *International Lighting Review* 2 (1955): 52.
33. Letter from Kalff to d'Aboville, January 9, 1956, quoted in Lootsma, "Een ode van Philips," 10–1.

## Chapter 5 Realizing the Music for the Philips Pavilion

34. “Verslag bespreking met architect Le Corbusier in Parijs over de Wereldtentoonstelling Brussel '58” [Report of a discussion with the architect Le Corbusier in Paris about the 1958 Brussels World’s Fair], February 25, 1956; LKM.
35. Literally, “firefighters” (“pumpers”), but in French, *style pompier* means “pretentious or pompous.”
36. Bálint András Varga, *Conversations with Iannis Xenakis* (London: Faber and Faber Limited, 1996), 57.
37. Marc Treib, *Space Calculated in Seconds* (New Jersey: Princeton University Press, 1996), 168. Original reference: entry no. 487, *Le Corbusier Sketchbooks, Vol. 2: 1950–1954* (Cambridge: MIT Press, 1981).
38. Le Corbusier considered “tape music” to be his own invention, rather peculiarly, considering the fact that electronic music had existed for years at the time he was writing. Editing segments of tape to create musical structures had been general practice in all electronic music studios, including the one in Paris, since the early 1950s.
39. Treib, *Space*, 170.
40. From a recorded interview with Le Corbusier in Jacques Barsac’s 1987 documentary *Le Corbusier 1887–1965*, aired in the Netherlands in three parts, on September 14, 21 and 28, 1996, by the TROS broadcasting company. From the context, one can conclude that the interview took place in 1955, just after the chapel in Ronchamp was completed but before it was put into service. Translation from Dutch subtitles by author; for original quote, see Appendix.
41. MacDonald, *Varèse*, 338.
42. *Ibid.*
43. Liner notes of *Music of Edgar Varèse: Robert Craft Conducts Woodwinds, Brass and Percussion*, featuring *Ionisation, Density 21.5, Intégrales, Octandre, Hyperprism, Poème électronique*. Columbia Records MS 6146.
44. Edgard Varèse’s 1954 datebook, Paul Sacher Foundation.
45. Wolfgang Amadeus Mozart’s Overture in B-Flat Major KV311a is composed in Paris in 1778, but there is serious doubt over whether it is a genuine Mozart work.
46. The concert with Varèse’s *Déserts* was only the second stereophonic broadcast in France. The first took place on June 18, 1950, and featured a radiophonic version of the play *Une larme du diable* [A tear of the devil] (1840) by Théophile Gautier (1811–1872) directed by René Clair (1898–1981). The broadcast was presented by the Club d’Essai de la Radio Française.
47. MacDonald, *Varèse*, 343.
48. INA Mémoire Vive 075.
49. Edgard Varèse’s 1954 datebook, Paul Sacher Foundation.
50. Harley, *Xenakis*, 4.
51. It was premiered by the Südwestfunk Orchester with the conductor Hans Rosbaud on October 15, 1955, during the Donaueschinger Musiktage.
52. Harley, *Xenakis*, 12.
53. François-Bernard Mâche, ed., *Portrait(s) de Iannis Xenakis* (Bibliothèque nationale de France, 2001), 32.
54. Varga, *Conversations*, 58.
55. Edgard Varèse’s 1955 datebook, Paul Sacher Foundation.
56. Letter from Le Corbusier to Varèse, January 6, 1955, Fondation Le Corbusier.
57. Edgard Varèse’s 1954 and 1955 datebooks, Paul Sacher Foundation.
58. Letter from Varèse to Le Corbusier, printed and translated in: Phaidon editors, *Le Corbusier Le Grand* (London: Phaidon Press Limited, 2008), 632.
59. Treib, *Space*, 20–21.
60. Sven Sterken, “Biografie van het Philips-paviljoen 1953–1959,” in *Make It New: Le poème électronique*, ed. Han le Blanc (Eindhoven: Stichting Alice, 2006), 63.
61. Letter from Le Corbusier to Kalff, September 14, 1956; LKM. Translation by author; for original quote, see Appendix.
62. Letter from Kalff to Le Corbusier, October 13, 1956; LKM. Translation by author; for original quote, see Appendix.
63. Evert Cornelis, assistant conductor to Willem Mengelberg, later became Philips’ Phonographic Industries’ art director for classical music.
64. Internal message from Hartong to Kalff, November 15, 1956; LKM. Translation by author; for original quote, see Appendix.
65. This remark is obviously based on sentences from two articles about Varèse that Schuitema enclosed with his letter to Kalff: from *Grove’s Dictionary of Music and Musicians*, “In later years Varèse came to believe that normal musical instruments are obsolete and that music should be written exclusively for electronic instruments,” and, from *The Gramophone Shop Encyclopedia of Recorded Music*, “He has composed music in keeping with his notion that the traditional orchestra is not capable of expressing our modern age.”
66. Letter from Schuitema to Kalff, November 19, 1956; LKM. Translation by author; for original quote, see Appendix.
67. Badings had then just begun composing electronic music; he was presumably mentioned because of his fame as a composer of symphonic music.
68. Letter from Kalff to Hartong, November 19, 1956; LKM.
69. Letter from Kalff to Varèse, November 29, 1956; LKM.
70. Treib, *Space*, 171.
71. *Ibid.*
72. Edgard Varèse’s 1956 datebook, Paul Sacher Foundation.

73. Ibid.
74. Van Dam, *Kalff*, 78. Original reference: PCA file 182.2. Translation by author; for original quote, see Appendix.
75. Letter from Kalff to Le Corbusier, February 4, 1957; LKM.
76. The Nederlandse Organisatie voor Toegepast Natuurwetenschappelijk Onderzoek (TNO).
77. Sterken, “Biografie,” 65.
78. Letter from Xenakis to Varèse, February 14, 1957; Paul Sacher Foundation.
79. Ultraviolet light.
80. W. Tak, “Een scenario voor het Philips paviljoen Wereldtentoonstelling 1958” [A scenario for the 1958 World’s Fair Philips Pavilion], February 7, 1957; LKM. Translation by author; for original quote, see Appendix.
81. Ibid. Translation by author; for original quote, see Appendix.
82. Strijp III, or Strijp R, was the third industrial area to be developed by Philips in Eindhoven (after Strijp S and T, R being the third letter of “Strijp”). Activities at Strijp III mainly involved making cathode-ray tubes for television sets.
83. Interview with Dick Raaijmakers by the author, The Hague, August 21, 2010; digital recording.
84. Wiel Cox, e-mail message to the author, June 6, 2012.
85. Interview with Wiel Cox by the author, Eindhoven, August 26, 2009; digital recording.
86. The idea of using small domes on the exterior of the pavilion for the speakers was eventually abandoned.
87. Letter from Kalff to Le Corbusier, April 2, 1957; LKM. Translation by author; for original quote, see Appendix.
88. Letter from Le Corbusier to Kalff, April 2, 1957; LKM.
89. Letter from Kalff to Le Corbusier, April 9, 1957; LKM.
90. Alexander von Vegesack, Stanislaus von Moos, Arthur Rüegg and Mateo Kries, eds., *Le Corbusier: The Art of Architecture* (Weil am Rhein: Vitra Design Stiftung gGmbH, 2007), 49–56.
91. W. Tak, “Bespreking op 23 april 1957 met de Heren Le Corbusier en Xenakis in Parijs” [Meeting with Le Corbusier and Xenakis on April 23, 1957, in Paris]; LKM.
92. L. Kalff, “Rapport de l’entretien que nous avons eu avec M. Le Corbusier, mardi le 12 mars Rue de Sevres 35, a Paris” [Report of the conversation we had with Mr. Le Corbusier on Tuesday, March 12, at Rue de Sevres 35, Paris]; LKM.
93. Letter from Varèse to Kalff, June 5, 1957; LKM. Translation by author; for original quote, see Appendix.
94. Letter from Le Corbusier to Varèse, June 22, 1957; Paul Sacher Foundation.
95. Letter from Varèse to Le Corbusier, July 22, 1957; Paul Sacher Foundation. “[O]eil et oreille ne synchronisent pas, que son et lumière ne sont pas de même essence, ne doivent pas s’empêtrer mais pour être efficaces doivent agir en opposition.”
96. Radio interview, November 1958. A recording is in Varèse’s private collection, archived at the Paul Sacher Foundation, CD 3, track 9. Transcription by the author. The interviewer is Margery Dundon; the exact date and place of broadcast are unknown.
97. Letter from Varèse to Le Corbusier, September 17, 1957; Fondation Le Corbusier.
98. Letter from Varèse to Le Corbusier, July 22, 1957; Paul Sacher Foundation.
99. Letter from Kalff to Varèse, July 24, 1957; Paul Sacher Foundation. Translation by author; for original quote, see Appendix.
100. Treib, *Space*, 103.
101. Letter from Le Corbusier to Varèse, July 29, 1957; Paul Sacher Foundation. “[Q]ui ont le respect des inventeurs” is translated as “who respect inventors” in Treib, *Space*, 174.
102. Telegram from Philips to Varèse, August 30, 1957; LKM.
103. Letter from Varèse to Le Corbusier, September 17, 1957, Fondation Le Corbusier.
104. There were now two people with almost identical names in the garage (there is no difference in pronunciation between “De Bruin” and “De Bruyn”). To avoid confusion, Simon Leo de Bruin of the exhibition department was thenceforth called “dikke” (fat) De Bruin, and Jan de Bruyn of ELA “dunne” (skinny) De Bruyn.
105. The design and the list included an Ondioline keyboard instrument as well, but no photographic or other evidence of its presence or use has been found. Some photos of the studio in the garage at Strijp III show fifteen GM2315 sine wave generators above the EL3800 mixing desk. However, these GM2315s were not used to produce music but to record the signals for the tape that controlled the automated show in the pavilion.
106. Notes for *Le poème électronique* in unidentified handwriting, September 18, 1957; Paul Sacher Foundation.
107. Tak, “De geluidseffecten,” 167.
108. Edgard Varèse’s 1957 datebook, Paul Sacher Foundation.
109. Loudspeakers had not yet been placed in the pavilion, so this figure could only be an estimate.
110. Handwritten text and drawings on stationery from the Atlanta hotel in Eindhoven, Paul Sacher Foundation. The original document was written in English, presumably for Varèse.
111. Felix Meyer and Heidi Zimmermann, eds., *Edgard Varèse: Composer, Sound Sculptor, Visionary* (Woodbridge, Suffolk: The Boydell Press, 2006), 342, cat. 165c. (Only six of the eleven drawings are mentioned in this book.)
112. See the description of Anton Buczynski’s equipment for panorama and reverberation level control in Chapter 5, 144–47.
113. Letter from Varèse to Le Corbusier, September 17, 1957; Fondation Le Corbusier.
114. Edgard Varèse’s 1957 datebook, Paul Sacher Foundation.
115. Letter from Scherchen to Varèse, September 18, 1957; Paul Sacher Foundation.
116. Letter from Varèse to Scherchen, October 21, 1957; Paul Sacher Foundation.

117. Letter from Xenakis to Kalff, October 3, 1957, quoted in Treib, *Space*, 85. When Xenakis wrote “several millions,” he was referring to old French francs. After 1960, one new franc equaled the value of hundred old ones.
118. Treib, *Space*, 85–8.
119. MacDonald, *Varèse*, 301.
120. *Ibid.*, 303.
121. *Ibid.*, 304.
122. *Ibid.*, 310–11.
123. Meyer and Zimmermann, eds., *Edgard Varèse*, 342.
124. Conversation between Chou Wen-chung and the author, Bilderberg Parkhotel Rotterdam, July 14, 2008.
125. In Roland de Beer, “Varèse deed ‘kwè-kwè,’” *de Volkskrant*, January 27, 1984:13, Tak mentioned that the recording had been made with musicians and singers from Jan Corduwener’s ballroom orchestra.
126. Letter from Kalff to Bomli, November 2, 1957; LKM. Translation by author; for original quote, see Appendix.
127. The New York performance of *Étude pour espace* on April 20, 1947, was recorded on three 78 rpm discs. Though MacDonald, *Varèse*, 311, and Helga de la Motte-Haber, *Die Musik von Edgard Varèse* (Hofheim: Wolke Verlag, 1993), 107, state that a recording of the performance appears in *Le poème électronique*, they are wrong.
128. Paul Sacher Foundation, *Varèse* CD 19, tracks 5 and 6. “Hilversum” is written on the original tape box.
129. See, for instance, MacDonald, *Varèse*, 378; Bart Lootsma, “Poème électronique: De reconstructie van een ontstaansgeschiedenis” [Reconstruction of a genesis], in *De bevrijding van de klank* [The liberation of sound], ed. Elmer Schönberger (Amsterdam: Stichting ASKO, 1984), 65; and De la Motte-Haber, *Die Musik von Edgard Varèse*, 107.
130. Manuscript at Paul Sacher Foundation.
131. Available on CD EVTS 1051 at the Paul Sacher Foundation.
132. Interview with Anton Buczynski by the author, Baarn, February 19, 2003; video recording.
133. Roland de Beer, “Varèse deed ‘kwè-kwè,’” *de Volkskrant*, January 27, 1984: 13.
134. *Ibid.*
135. Letter from Varèse to Kalff, July 11, 1957; LKM. The festival Décade de la musique nouvelle Américaine took place in early October 1957.
136. Centre Belge de documentation musicale (CEBEDEM), “Index des compositeurs affiliés,” <http://www.cebedem.be/fr/compositeurs/s/135-stehman-jacques>; accessed July 27, 2012. It is not clear which of Varèse’s works was performed at the festival.
137. Fernand Ouellette, *Edgard Varèse: A Musical Biography* (London: Calder & Boyars, 1973), 198.
138. Letter from Varèse to Chou Wen-chung, December 18, 1957; Paul Sacher Foundation.
139. Roland de Beer, “Varèse deed ‘kwè-kwè,’” *de Volkskrant*, January 27, 1984: 13.
140. *Ibid.*
141. *Ibid.*
142. Letter from Varèse to Xenakis, December 21, 1957, quoted in Ouellette, *Edgard Varèse: A Musical Biography*, 198–99.
143. Louise Varèse’s datebook, December 25–26, 1957; Paul Sacher Foundation (there are two datebooks of hers for 1957).
144. *Ibid.*, December 27, 1957.
145. Louise Varèse apparently referred to the voice at 3’38” as singing “Hooga” (and not “Oh God”).
146. Louise Varèse’s datebook, January 7, 9 and 10, 1958; Paul Sacher Foundation.
147. *Ibid.*, March 24, 1958.
148. *Ibid.*, January 20, 1958.
149. *Ibid.*, January 23, 1958. Tak’s enthusiasm met with suspicion, however. Louise Varèse wrote in her datebook: “Tak enthusiastic about V’s work???”
150. Treib, *Space*, 194. Treib mentioned that a short segment of the music was presumably played at a January 1958 meeting with Philips management. He based this assumption on an undated memo, probably from late January or early February. To my understanding, this memo could also have referred to the demonstration on February 6.
151. Louise Varèse’s datebook, February 6, 1958; Paul Sacher Foundation.
152. Letter from Varèse to Odile Vivier, quoted in Treib, *Space*, 197.
153. Louis Kalff, “Recapitulation of the events on 6 and 7 February 1958,” February 15, 1958; LKM.
154. Louise Varèse’s datebook, February 8–13, 1958; Paul Sacher Foundation.
155. Treib, *Space*, 266 (endnote 71).
156. Jessica Voeten, *Een Nederlands wonder: Vijftig jaar Holland Festival* (Amsterdam: Walburg pers / Stichting Holland Festival, 1997), 157–67. Henri Tomasi conducted Claude Debussy’s *Pelléas et Mélisande* in the opening concert of the first Holland Festival, which took place on June 15, 1948. He reappeared there in 1953, 1954 and 1956, when he conducted his own opera *Sampiero Corso*. Tomasi stopped conducting in 1957 because of advancing deafness in his right ear.
157. In 1957, Henri Tomasi composed music for a *son et lumière* spectacle at the castle at Saverne.
158. Over the next forty years, Pierre Arnaud would produce more than hundred sound-and-light spectacles.
159. E-mail message from Pierre Arnaud to Peter Wever, May 18, 2009. Wever traced Arnaud and his son in Paris and received extensive documentation about the history of Studio DMS, on which this information is based.
160. *Ibid.*
161. Interview with Anton Buczynski by the author, Baarn, February 19, 2003; video recording.

162. Varèse lived in Turin approximately from age ten to seventeen.
163. Conversation between Chou Wen-chung and the author, Bilderberg Parkhotel Rotterdam, July 14, 2008.
164. Louise Varèse's datebook, March 21, 1958; Paul Sacher Foundation.
165. E-mail message from Huub Houët, Hub. Houët's son, to the author, May 8, 2012.
166. Level variation between two loudspeakers that simulates the position of sound sources between them.
167. Tak, "Het Elektronisch Gedicht," 167–69.
168. A similar technique was later used by Karlheinz Stockhausen, who created rotating sounds with four channels for his composition *Kontakte* (1959–1960). It is not clear whether Stockhausen was familiar with the earlier experiments in the Netherlands. See: Karlheinz Stockhausen, *Nr. 12 – Kontakte – Elektronische Musik – Realisationspartitur*, (London: Universal Edition, 1968), 3.
169. Tak, "Het Elektronisch Gedicht," 167–69.
170. The same method was used in the production of Badings' *Kain en Abel*; see Chapter 3, 66–72.
171. Notes for *Le poème électronique* in unidentified handwriting, September 18, 1957; Paul Sacher Foundation.
172. Three channels on half-inch magnetic tape was an existing format at the time, though one mainly used in the United States.
173. *Le poème électronique* utilized a main film (for the *écrans*) and a second film consisting of three small projected elements (the *tri-trous*) around the main film. As these were projected on both sides of the interior of the pavilion, a total of four projectors were needed.
174. Interview with Dick Raaijmakers by the author, The Hague, August 21, 2010; digital recording.
175. Louise Varèse wrote a brief report of this visit in her datebook under April 5 and 6, 1958, so the visit presumably took place on the 5th. Louise Varèse's 1957 datebook, Paul Sacher Foundation.
176. By April 1958, Badings had produced *Kain en Abel*, *Variations électroniques* and *Evolutionen*. Therefore, Varèse's opinion must have been based on one or more of these compositions.
177. Jean Petit, ed., *Le poème électronique: Le Corbusier* (Paris: Les éditions de minuit, 1958). The book was released in a hardcover French version and in thinner softcover versions in French, Dutch, German, English and Spanish.
178. According to Harley, *Xenakis*, 18, *Concret PH* was produced in stereo at GRM in 1961, and a four-channel version was made at GRM in 1969 (original reference: François Delalande, 'Il faut être constamment un immigré': *Entretiens avec Xenakis* ["One has to be an immigrant constantly": An interview with Xenakis] (Paris: INA-Buchet/Chastel, 1997). A revised version from 1968 entitled *Concret PH II* was released on record (Nonesuch H-71246 and Erato STU 70530).
179. Nouritza Matossian, *Xenakis* (New York: Kahn & Averill, 1986), 111. Saint Polycarpus (69–155) was a second-century Christian bishop of Smyrna (a city of ancient Greece, now in Turkey). He died a martyr, bound at the stake and then stabbed after the fire failed to touch him.
180. Letter from Xenakis to Scherchen, June 25, 1957; Xenakis Archives; quoted in Matossian, *Xenakis*, 121. Maurice Auguste Chevalier (1888–1972) was a French singer who performed in bars and in the revues at the Folies-Bergère in Paris.
181. Treib, *Space*, 205–7.
182. *Ibid.*
183. *Ibid.* It is unclear to me why Treib wrote that "the character of the music is left unspecified," since the description appears to match the music in quite a specific way.
184. Letter from Xenakis to Kalff, December 2, 1957; LKM: "sobre, frappant et de qualité artistique au moins aussi bonne que le reste du spectacle."
185. Harley, in *Xenakis*, 18, writes that Xenakis "was forced to work on it at the rather primitive facilities of the Philips offices in Paris." Although DMS was owned by Philips Disques France, it was not a Philips office.
186. Letter from Xenakis to Kalff, March 11, 1958; LKM: "J'ai commencé avec Arnaud qui a fait bonne impression. On a fait la prise de son du charbon, c'est très bien."
187. Pierre Arnaud, e-mail message to Peter Wever, May 18, 2009. Translation by author.
188. The Philips Pavilion would indeed have a horizontal loudspeaker route encircling the audience (see Chapter 6, 157–65).
189. Letter from Xenakis to Kalff, March 11, 1958; LKM.
190. Letter from Kalff to Xenakis, March 13, 1958; LKM.
191. Letter from Xenakis to Kalff, March 17, 1958; LKM.
192. Letter from Tak to Xenakis, March 24, 1958; LKM: "reproduits avec toutes les possibilités disponibles."
193. *Ibid.* Translation by author; for original quote, see Appendix.
194. Letter from Xenakis to Kalff, April 3, 1958; LKM. According to Harley, *Xenakis*, 18, the intermission music was recorded on one monophonic tape.
195. Tak's suggestion that Xenakis use the "third dimension of sound" in his composition was not just a generous offer; it was the only way the sounds on the three tracks could move at independent speeds and in opposite directions. Playing sounds on one route simultaneously and independently was technologically impossible in the installation in the pavilion (see Chapter 6, 157–65).
196. Letter from Xenakis to Kalff, April 7, 1958; LKM.
197. Internal memo from Kalff, April 24, 1958; LKM.
198. I. Xenakis, "Het architectonische ontwerp van Le Corbusier en Xenakis voor het paviljoen" [Le Corbusier's and Xenakis' architectonic design for the pavilion], *Philips Technisch Tijdschrift* 5 (1958): 129.
199. Thus, there is no reason to date the drawing in fig. 2.76 before December 1956.

## Chapter 6

**Le poème électronique in Brussels**

200. Conversation with former Philips Pavilion technicians, Brussels, August 26, 2009.
201. Tak, "Het Elektronisch Gedicht," 168.
202. For instance, Varèse wrote to Chou Wen-chung, "Yes, the 'Poème Electronique' went very well. Though distributed over three instead of four hundred loudspeakers, the work did not lose its effectiveness." Letter from Varèse to Chou Wen-chung, November 19, 1958; Paul Sacher Foundation.
203. Philips press release, "'Het elektronische gedicht' in het Philips paviljoen" ["The electronic poem" in the Philips Pavilion] 1958, private collection of Peter Wever.
204. Most of the speakers are mounted on the walls, and, unlike in fig. 2.78, their spacing is irregular. The asbestos layer has only been sprayed onto some walls. No exact date is given for the photos, but it can be concluded that they were taken after February 7, 1958, but before the end of the month, since the asbestos was sprayed on sometime in February. (See Sterken, "Biografie," 67.)
205. Buczynski arrived in Eindhoven on February 19, 1958, and visited the pavilion soon after. In his photo, the asbestos layer in peak A is identical to that in Hans de Boer's pictures: the concrete tiles and the steel cables are still visible to the left of peak A; to the right, the asbestos layer is already present (see fig. 2.86).
206. Tak, "Het Elektronisch Gedicht," 168. Whether or not there were exactly 25 low-frequency loudspeakers cannot be determined from the photos.
207. Similar technology was used in 1940 in the road show equipment for Walt Disney's *Fantasia* (see Chapter 2, 40–5).
208. Of these 180 control signals, only sixty were used for the sound system.
209. The shorter sound routes therefore must have shared rotary switches. This conclusion does not contradict other sources.
210. Kalf, Tak and De Bruin, "Verwezenlijking," 164. The original Dutch term for electrical shaft is *elektrische as*. In the English edition of the same article (*Philips Technical Review* 2/3 (1958/59): 39), this is translated as "magslips."
211. Interview with Tak, November 11, 1983, in: Bart Lootsma, "Een ode van Philips aan de vooruitgang," *Wonen-TABK* 2 (1984): 10. Lootsma described the history of *Le poème électronique* as "ook één van mislukking, van niet waargemaakte pretenties, moeizaam bedwongen conflicten en een falende samenwerking tussen verschillende kunsten en de techniek." [also one of failure, of unfulfilled pretensions, laboriously conquered conflicts and an unsuccessful collaboration between various art forms and technology]. In "Le poème Electronique," *Wonen-TABK* 2 (1984): 29, Lootsma wrote that synchronization had caused problems because the interlock machine meant to take care of it had never been installed, and as a result, the program had never been shown as intended. His assertion was supposedly confirmed by the technicians involved. No reference for these claims is given in the article, and the consulted technicians' names are not mentioned. Interview with Tak in: Roland de Beer, "Varèse deed 'kwè-kwè,'" *de Volkskrant*, January 27, 1984: 13. "Die banden hebben nooit synchroon gelopen, we hadden geen goed schakelsysteem." [Those tapes never ran in sync; we didn't have a proper switching system].
212. Vancoppenolle is one of six former Philips Pavilion technicians traced by Peter Wever in 2009.
213. Paul Vancoppenolle, e-mail message to author, July 11, 2012.
214. Interview with Anton Buczynski by the author, Baarn, February 19, 2003; video recording. According to the date written on the perfo master tape in the archive at the Institute of Sonology, the final mix was made on May 11, 1958. The number XV presumably indicates that this was the fifteenth version.
215. Letter from Kalf to Xenakis, April 9, 1958; LKM: "travailler jour et nuit pour avoir la composition de Varèse prête pour le pavillon avec tous les effets troisdimensionnels."
216. Louise Varèse's datebook, April 11, 1958; Paul Sacher Foundation.
217. Letter from Kalf to Xenakis, April 9, 1958; LKM.
218. "Philips-paviljoen opende zijn deuren nog niet: Architect en scenarioschrijver Le Corbusier was niet tevreden met het *Poème électronique*" [Philips Pavilion did not open its doors: Architect and scenario writer Le Corbusier was dissatisfied with *Poème électronique*], *Algemeen Handelsblad*, April 19, 1958: 13.
219. Louise Varèse's datebook, entries for April 11, 12, and 14–7, 1958; Paul Sacher Foundation.
220. *Ibid.*, April 17, 1958. Kalf's April 9, 1958, letter to Xenakis dates this presentation on April 15, 1958.
221. Annotated photo album at the main Philips Belgium office in Brussels.
222. April 18: demonstration for Philips' board of directors. April 22: demonstration for the company's Belgian management. April 23: demonstrations for the commissioner general of the World's Fair, Georges Moens de Fernig (1899–1978), and the president of Austria. May 9: demonstration for the architect Richard Neutra (1892–1970).
223. Letter from Kalf to Xenakis, April 9, 1958; LKM.
224. Internal memo by Kalf, April 24, 1958; LKM.
225. Letter from Varèse to Xenakis, May 2, 1958, quoted in Ouellette, *Varèse*, 199.
226. Annotated photo album at the main Philips Belgium office in Brussels.
227. Letter from Edgard Varèse to Louise Varèse in Rome, May 26, 1958; Paul Sacher Foundation. Louise Varèse interrupted her stay in Brussels for a vacation in Rome from May 15 to June 5, 1958.
228. Letter from Edgard Varèse to Louise Varèse in Rome, May 27, 1958; Paul Sacher Foundation. "And the connection which I will insist *must* be made – and *they will!*" The letter was signed "Emmerdeur le Grand" [The big troublemaker].



229. Tak, “De geluidseffecten,” 167.
230. Louise Varèse’s datebook, June 18, 1958; Paul Sacher Foundation. In Ouellette, *Varèse*, 203, it is written that Varèse left for Paris on July 1, 1958.
231. Louise Varèse wrote in her date book on July 4, 1958, that she was aboard with a Mr. and Mrs. Shapero. On July 7, her datebook mentions New York. In Ouellette, *Varèse*, 203, it says Varèse returned to New York on the liner *Liberté*, but no date is given.
232. Letter from Le Corbusier to Kalff, July 22, 1958, quoted and translated in Treib, *Space*, 113; original reference: Fondation Le Corbusier.
233. Letter from Kalff to Le Corbusier, July 28, 1958, quoted and translated in Treib, *Space*, 114; original reference: Fondation Le Corbusier.
234. Kees Tazelaar, “Poème électronique,” trans. Jane Bemont (program notes for the Varèse symposium at the Holland Festival, Amsterdam, June 12, 2009).
235. Treib, *Space*, 170.
236. Le Corbusier’s scenario originally called for the use of a one-minute scene from a film about his architecture by Pierre Kast, *l’Architecte du bonheur* [Architect of happiness].
237. Kees Tazelaar, “Poème électronique,” trans. Jane Bemont (program notes for the Varèse symposium at the Holland Festival, Amsterdam, June 12, 2009).
238. *Music of Edgar Varèse*, Columbia Records MS 6146. Besides *Le poème électronique*, the record includes *Ionisation*, *Density 21.5*, *Intégrales*, *Octandre* and *Hyperprism*.
239. Letter from Edgard Varèse to Fernand Ouellette, March 29, 1961, quoted in Ouellette, *Varèse*, 212.
240. Liner notes of the LP *Music of Edgar Varèse*, Columbia Records MS 6146.
241. Paul Vancoppenolle, e-mail message to author, July 11, 2012.
242. Annotated photo album at the main office of Philips Belgium in Brussels.

## Part III

### Chapter 7

#### The First Steps towards a Dutch Electronic Music Studio

1. Gottfried Michael Koenig, in conversation with the author, February 22, 2012.
2. Peter Peters, *Eeuwige jeugd: Een halve eeuw Stichting Gaudeamus* [Eternal youth: 50 years Gaudeamus Foundation] (Amsterdam: Donemus, 1995), 9.
3. Leo Samama, *Zeventig jaar Nederlandse muziek 1915–1985* [Seventy years of Dutch music 1915–1985] (Amsterdam: E.M. Querido’s uitgeverij B.V., 1986), 206.
4. Gottfried Michael Koenig, in conversation with the author, February 22, 2012.
5. Letter from Maas to Meyer-Eppler, September 18, 1953; Netherlands Music Institute. The letter only mentions “2. Stage”; Heribert Henrich of the music archive at the Akademie der Künste in Berlin explained what was meant and also provided the title and date of Meyer-Eppler’s lecture.
6. Marietta Morawska-Büngeler, *Schwingende Elektronen* [Oscillating electrons] (Cologne: P. J. Tonger Musikverlag, 1988), 9–13.
7. Hugh Davies, ed., “International Electronic Music Catalog,” *Electronic Music Review* 2/3 (1967): 49; Robert Beyer / Herbert Eimert, *Klang im unbegrenzten Raum* [Sound in unlimited space] (1951–1952, 10’20”), *Klangstudie I* (1952, 3’50”), *Klangstudie II* (1952–1953, 4’30”), *Ostinate Figuren und Rhythmen* (1953, 3’45”); Herbert Eimert, *Struktur 8* (1953, 4’00”); Karlheinz Stockhausen, *Studie I* (1953, 9’18”); Herbert Eimert, *Glockenspiel* (1953, 1’00”); Karel Goeyvaerts, *Compositie nr. 5 met zuivere tonen* [Composition no. 5 with pure tones] (1953, 2’30”); Hermann Heiss, *Elektronische Studie* (1953, 0’40”).
8. Letter from Maas to Vermeulen, March 12, 1954; Netherlands Music Institute.
9. “Elektronische Muziek,” *Utrechts Nieuwsblad*, May 17, 1954. “De elektronische componist heeft ter realisering van zijn kunst geen medium meer nodig. Van hem gaat de kunst direct naar de luisteraar.”
10. Letter from Vermeulen to Maas, June 1, 1954; Netherlands Music Institute.
11. Letter from Maas to Meyer-Eppler, May 28, 1954; Netherlands Music Institute.
12. Letter from Meyer-Eppler to Passchier, June 5, 1954; Netherlands Music Institute.
13. This setup was presumably based on Meyer-Eppler’s previously suggested list of equipment.
14. Prior to the experiments at the NRU, Meyer-Eppler had given the lecture “Die elektrischen Instrumente und Neue Tendenzen der elektroakustischen Klanggestaltung” [Electronic instruments and new trends in electroacoustic sound design] at the Gravesano music and electroacoustics congress in August 1954 (see Chapter 2, 59–61) He repeated it at the Gemeentemuseum in The Hague on September 29, 1954. Another lecture in Hilversum was planned some days after but canceled. In Peters, *Eeuwige jeugd*, 36, it is mentioned that Meyer-Eppler gave a lecture at 1954’s Gaudeamus Muziekweek. But neither the Muziekweek program announced in “Berichten Binnenland” [Domestic news], *Mens en Melodie* 8 (1954): 264, nor Wouter Paap’s review of Muziekweek, “Bilthoven, Muziekweek Gaudeamus,” *Mens en Melodie* 9 (1954): 297–99, mentions this lecture, nor is there any trace of it in correspondence between Maas and Meyer-Eppler.
15. Production list of electronic music productions, compiled by Roelof Vermeulen; Institute of Sonology archive.
16. As discussed in Chapter 3, 72–7, cameraman John van der Meulen’s music for the 1953 film *The Conquered Planet* used electronics.

17. Wouter Paap, "Bilthoven, Muziekweek Gaudeamus," *Mens en Melodie* 9 (1954): 297–98. According to one of the participants, the course was the backbone of 1954's Muziekweek.
18. Letter from Vermeulen to Maas, November 25, 1954; Netherlands Music Institute.
19. Letter from Maas to Vermeulen, December 15, 1954; Netherlands Music Institute. Translation by Richard Barrett; for original quote, see Appendix.
20. Letter from Vermeulen to Maas, May 26, 1955; Netherlands Music Institute.
21. "Resumé van handelingen en initiatieven o.a. van het Contactorgaan Electronische Muziek, betreffende elektronische muziek en de inrichting van een studio voor elektronische muziek in Nederland" [Summary of actions and initiatives, including those for the Contactorgaan Electronische Muziek, concerning electronic music and the establishment of a studio for electronic music in the Netherlands]; supplement for a press conference held by STEM and CEM at Utrecht University, June 12, 1961.
22. Letter from Maas to Vermeulen, November 8, 1954; Netherlands Music Institute. Badings would indeed use these instruments in *Kain en Abel* in 1956.
23. *Ibid.*

## Chapter 8

### An Organization for the Promotion of Electronic Music

24. Badings' *Variations électroniques* was made at Philips Research Laboratories in August 1957, though not in Room 306.
25. Peters, *Eeuwige jeugd*, 53. No further information about this study center has been found.
26. Minutes of the meeting at Gaudeamus, Bilthoven, July 9, 1956; author's collection.
27. A word made up by Wouter Paap that means something like "twelve-tone nonsense."
28. Wouter Paap, "Muziekweek Gaudeamus," *Mens en Melodie* 9 (1956): 290: "het waarlijk-scheppend talent van muziekstudenten, die rondtobben in de schemerige gebieden van het Schoenbergianisme. Zij boren zich in de klank, maar komen aan de muziek niet toe."
29. Henk Badings, *De hedendaagse Nederlandsche muziek* (Amsterdam: Bigot en Van Rossum, 1936).
30. Wouter Paap, "Elektronische Muziek," *Mens en Melodie* 9 (1956): 270–71.
31. *Ibid.*
32. Paap, "Muziekweek Gaudeamus," 292.
33. Werner Meyer-Eppler, "Wissenschaftliche Grundlagen der elektronischen Musik" [Scientific fundamentals of electronic music], music archive, Akademie der Künste, Berlin.
34. Stockhausen would indeed have a sphere-shaped auditorium at his disposal at the 1970 Osaka World's Fair.
35. "Gaudeamus-week: Slotbeschouwing" [Gaudeamus week: closing considerations], *Utrechts Nieuwsblad*, September 3, 1956: 7. The article does not make clear whether the music was played on a four-channel tape machine through four loudspeaker groups or a stereo tape was played instead. At the time, four-channel tape machines were not available at Philips, but it is possible that one was brought from Germany for the occasion.
36. Enclosure with invitation to the Contactorgaan assembly of December 18, 1956; author's collection.
37. Minutes of the Contactorgaan assembly of December 18, 1956; author's collection.
38. Jan Boerman, in conversation with the author, The Hague, June 20, 2008.
39. R. Vermeulen, "Electrofonische muziek," internal memo, December 20, 1956; Philips Company Archives.
40. Minutes of the Contactorgaan assembly, January 23, 1957; author's collection.
41. Enclosure to the invitation for the Contactorgaan assembly of March 15, 1957; author's collection.
42. Minutes of the Contactorgaan assembly of March 15, 1957; author's collection.
43. Letter from Huydts to Kok, March 21, 1957: "Duitse, Franse en andere omschrijvingen zijn te doelgericht om algemeen aanvaardbaar te zijn." Author's collection. A copy of a March 13, 1957, letter from De Leeuw was enclosed.
44. Definition from the minutes of the CEM assembly of April 16, 1957; author's collection. Translation by author; for original quote, see Appendix.
45. Minutes of the Contactorgaan assembly of March 15, 1957; author's collection.
46. Jessica Voeten, *Een Nederlands wonder: Vijftig jaar Holland Festival* [A Dutch miracle: Fifty years of the Holland Festival] (Amsterdam: Walburg pers / Stichting Holland Festival, 1997), 11.
47. Philips' involvement in the Holland Festival also linked the Philips Pavilion project, Benjamin Britten and Henri Tomasi (see Chapter 5, 139–44). The first Holland Festival performance, in 1948, had been of the opera *Pelléas et Mélisande* by Claude Debussy, with Tomasi conducting the Concertgebouw Orchestra (Voeten, *Holland Festival*, 11). Tomasi returned to the festival as a conductor in 1953, 1954 and 1956, when he conducted his own opera *Sampiero Corso* and Benjamin Britten's *Serenade opus 31* (*Ibid.*, 163–67). Britten himself was also a prominent guest at the Holland Festival. The first edition had included the continental premiere of Britten's *The Beggar's Opera*, performed by his own English Opera Group. Britten frequently returned as a composer, conductor and pianist in the first 20 years of the festival's existence. In 1954, the Holland Festival's first program specifically for young people presented Britten's *A Young Person's Guide to the Orchestra* (*Ibid.*, 19).
48. This would have been the second performance of that work at the Holland Festival, since it had premiered there the previous year.
49. Letter from Bomli to Diamand, March 29, 1957; author's collection.
50. Letter from Diamand to Bomli, May 4, 1957; author's collection.
51. Minutes of the CEM assembly of June 1, 1957; author's collection.
52. Minutes of the CEM assembly of July 1, 1957; author's collection.

53. The Philips Ontspanningsgebouw, mentioned in Chapter 1, 36–8, was renamed the Philips Schouwburg after its 1935 renovation.
54. Minutes of the CEM assembly of September 9, 1957; author's collection.
55. Minutes of the CEM assembly of October 23, 1957; author's collection.
56. List of electronic music works produced in the Netherlands, compiled by Roelof Vermeulen; author's collection.
57. Interview with Dick Raaijmakers by the author, The Hague, August 21, 2010; digital recording.
58. *Ibid.*, and concert announcements in *Eindhovens Dagblad*, October 26, 1957, and *De Tijd*, November 8, 1957.
59. Interview with Dick Raaijmakers by the author, The Hague, August 21, 2010; digital recording.
60. Minutes of the CEM assembly of February 7, 1958; author's collection.
61. Minutes of the CEM assembly of April 14, 1958; author's collection.
62. Letter from Diamand to Bomli, April 16, 1958; author's collection.
63. Letter from Bomli to Diamand, April 18, 1958; author's collection.
64. Letter from Bomli to Diamand, May 5, 1958, author's collection. See Chapter 3, 72–7, for a description of Badings' *Variations électroniques*.
65. Letter from Diamand to Bomli, May 16, 1958; author's collection.
66. Minutes of the CEM assembly of January 9, 1959; author's collection.
67. Minutes of the CEM assembly of February 12, 1959; author's collection.
68. Minutes of the CEM assembly of March 16, 1959; author's collection.
69. Ton de Leeuw's *Antiphonie* was presented in a concert by the Danzi Wind Quintet, along with Karlheinz Stockhausen's *Zeitmasse*, Ernst Krenek's *Pentagram*, Bo Nilsson's *20 Gruppen* and Hans Werner Henze's *Kwintet*.
70. Minutes of the CEM assembly of October 23, 1957; author's collection.
71. Minutes of the CEM assembly of February 7, 1958; author's collection.
72. Minutes of the CEM assembly of April 14, 1958; author's collection.
73. Minutes of the CEM assembly of June 11, 1958; author's collection. The work by Ton de Leeuw was *Elektronische studie*, made at the NRU studio in 1957 and revised at Philips in 1958.
74. Besides electronic music and *musique concrète*, the International Days of Experimental Music featured instrumental works by Anton Webern, Igor Stravinsky (the dodecaphonic *Threni, id est Lamentatio Jeremiae*), John Cage, Christian Wolf, Edgard Varèse (*Densité 21.5*), Olivier Messiaen, Arnold Schoenberg, Mauricio Kagel, Pierre Boulez (Piano Sonata no.2, *Le marteau sans maître*), Luigi Nono (*Incontri*), Bruno Maderna (*Dimensioni* for flute and tape), Earle Brown, Luciano Berio, Henri Pousseur and Karlheinz Stockhausen (*Kontra-Punkte*).
75. Lachman's radio cantata was commissioned by AVRO specifically for radio broadcast and only included some echo effects in the instrumental recordings. It is therefore not included in major lists of electronic music works.
76. Ton de Leeuw, "Experimentele muziek te Brussel," *Mens en Melodie* 11 (1958): 344–45: "de nieuwe technische middelen in het geheel van de klassiek-romantische wetmatigheden te integreren."
77. *Ibid.*, 344–45. Translation by author; for original quote, see Appendix.
78. Minutes of the CEM assembly of October 15, 1958; author's collection.

## Chapter 9

### A Temporary Studio for Electronic Music Education and Production

79. Reinink was also chairman of the Holland Festival.
80. No further evidence has been found for this statement.
81. The occasion was the production of Badings' *Kain en Abel* in the acoustics department of Philips Research Laboratories.
82. It remains unclear which studio was meant, but it was certainly not an electronic music studio.
83. Letter from Bomli on behalf of the Contactorgaan Elektronische Studio (*sic*) to Reinink at the Ministry of Education, Arts and Sciences, March 9, 1957; author's collection.
84. Minutes of the CEM assembly of March 15, 1957; author's collection.
85. Letter from the Netherlands Ministry of Education, Arts and Sciences to Bomli, May 7, 1957; author's collection.
86. Minutes of the CEM assembly of June 1, 1957; author's collection.
87. Letter from H. A. Bakels, deputy secretary of Technische Hogeschool Delft, to the Contact-Organ Elektronische Studio (*sic*), August 2, 1957; author's collection.
88. Minutes of the CEM assembly of September 9, 1957; author's collection.
89. Jan Mul, "Verslag opening studio Delft" [Report on Delft studio opening], *de Volkskrant*, September 30, 1957: 2. Translation by author; for original quote, see Appendix.
90. Willem Kok, "Harmonische Orgels" (Ph.D. dissertation, Technische Hogeschool Delft, 1955), 97.
91. Minutes of the CEM assembly of December 12, 1957; author's collection.
92. In 1964, Peter Schat composed the opera *Labyrinth*, which included electronic music produced at STEM in Utrecht. Schat then compiled a tape of the electronic music from *Labyrinth* in 1965, which could be performed as a self-contained work, called *De Aleph*.
93. *The Flying Dutchman* and *Variations électroniques*.
94. *Achter de Schermen* and *Fuel for the Future*.
95. In the commercial *Philips: Light/Luz/Lumière/Licht* by Jens Hendriksen.
96. On the CD *Archival Series: Musique Concrète Soundtracks to Experimental Short Films 1956–1978: Volume One*, the electronic music in *Glas* is credited to Tom Dissevelt. Dissevelt's name does indeed appear in the end titles of *Glas*, but as the bass player in the jazz combo, not the composer of the electronic music.

97. *Glas* is available on the DVD *Bert Haanstra Compleet* (Hilversum: Just Bridge Entertainment, 2007).
98. *Story in the Rocks* was made available on DVD to the author by the Shell Nederland Filmcentrale, where it is filed under catalogue no. SH 001.
99. Production documentation of Toneelwerkgroep Test, file no. 990420, Nederlands Theater Instituut, Amsterdam.
100. Marleen van Hall is the daughter of Gijs van Hall (1904–1977), a resistance fighter and politician and the mayor of Amsterdam from 1957 to 1967. She married the architect John Habraken (\*1928).
101. Jeanne van Schaick-Willing, “Cultuur-snobisme” [Cultural snobbery], *De Groene Amsterdammer*, March 1957: “geklots van de wateren van het onderbewustzijn en het gegorgel van de schuldgevoelens.” Production documentation of Toneelgroep Test, file no. 990420, Nederlands Theater Instituut, Amsterdam.
102. Badings had composed music with electronic sounds for a 1952 radio play of Yeats’ *The Countess Cathleen* and the 1956 television play *De nacht van morgen*.
103. See for instance: Hugh Davies, ed., “International Electronic Music Catalog,” *Electronic Music Review* 2/3 (1967): 120. The music for the other work in Test III, Ionesco’s *Jack, or the Submission*, is not mentioned in any catalogue, but it was presumably produced in the studio in Delft as well. According to a list of electronic music productions made by Roelof Vermeulen, the music for *The Bald Prima Donna* was produced in November 1957.
104. Righarts’ *Jan Klaassen* and Van der Kooy’s *Klankstudie* are mentioned in Davies’ *International Electronic Music Catalog* as pieces produced in the studio in Delft. The Test III program says Raaijmakers’ *Klankstudie over één motief* was produced at the Philips Research Laboratories studio. However, this piece does not appear in any catalog or other documentation, and Raaijmakers does not remember it. It is highly unlikely that a popular Kid Baltan work would have been presented in this context, and at the time of Test III, Raaijmakers had not yet produced any other works. The piece presented was presumably a preliminary version of *Tweeklank (Contrasts)*.
105. Letter by Marleen van Hall and Tymen van der Kooy to the Dutch House of Representatives’ committee for education, arts and sciences, November 20, 1958; author’s collection. Translation by author; for original quote, see Appendix.
106. *Ibid.*: “de jonge, aankomende componist, die wil werken in de elektronische muziek.”
107. *Ibid.*: “dat hij in geen enkel opzicht kan overzien voor welk publiek hij werkt, of en hoe zijn werk tot klinken wordt gebracht.”
108. *Ibid.* Translation by author; for original quote, see Appendix.
109. *Ibid.*: “Daarna zou de jonge componist voor het eerst weten, voor wie, waarvoor en met wie hij werkt.”
110. After the performance in the Stadsschouwburg Amsterdam, Test IV was repeated ten times in the small concert hall at the Amsterdam Concertgebouw, which is semicircular.
111. Jan Cornelis Rietveld was the son of architect and furniture designer Gerrit Rietveld (1888–1964).
112. “Experimenteel toneel: Gezelschap ‘Test’ met Adamov’s ‘Ping-Pong,’” *Utrechtisch Nieuwsblad*, June 4, 1959: 9: “de suggestie van een vreemde wereld, waarin wij vandaag de dag met ideeën over symboliek der werkelijkheid leven.”
113. Spek was in the Netherlands in the summer of 1993 and visited Raaijmakers’ *Fort Klank* project in Asperen. Raaijmakers made notes on his last telephone conversation with Spek on September 12, 1993.
114. Production documentation of Toneelgroep Test, file no. 990420, Nederlands Theater Instituut, Amsterdam.
115. Theater Instituut Nederland, “Een nieuwe zaal voor Toneelgroep Studio” [A new theater for Toneelgroep Studio]; <http://wiki.theaterencyclopedie.nl/wiki/Canon:1962> (accessed September 25, 2012): “zonder gordijn, zonder afstand tussen u en de spelers.”
116. Student records, Royal Conservatoire. During World War II, the Royal Conservatoire was known as the Rijksconservatorium (State Conservatory).
117. However, between 1961 and 1963, Boerman and Van de Weetering collaborated on the ballet *Illusie* for the Dutch National Ballet, which premiered on October 22, 1963, at the Stadsschouwburg in Amsterdam. The music for *Illusie* was written for a large orchestra and did not include electronics.
118. Letter from Kok to Bomli, December 2, 1959; author’s collection.
119. CD booklet for *The Complete Tape Music of Jan Boerman*, CV-NEAR 04/05/06/07/08, 36.
120. Letter from Escher to Kok, October 4, 1957; author’s collection.
121. Letter from Escher to Kok, August 27, 1959, and letter from CEM to Kok, September 1, 1959; author’s collection.
122. Letter from Escher to Spek, April 14, 1960, quoted in Voermans, *Peter Schat – Rudolf Escher*, 35.
123. The television play *The Long Christmas Dinner* was directed by Theun Lammertse and broadcast on December 24, 1960.
124. Letter from Escher to Schat, November 27, 1960, in Voermans, *Peter Schat – Rudolf Escher*, 110.
125. A similarly modified Bruel & Kjaer filter was later installed at STEM in Utrecht and is still available at the Institute of Sonology in The Hague. The Peekel model number of this later version is TF296, and it is built around a Bruel & Kjaer type 1612 filter.

## Chapter 10

### Continuing the Work of the Philips and TH Delft Studios in Utrecht and Bilthoven

126. Letter from Maas to Kok, November 26, 1957; author’s collection.
127. Minutes of the CEM assembly of February 7, 1958; author’s collection.
128. W. Kok, “Algemene beschouwing over elektronische muziek en de daarmee samenhangende praktische vraagstukken” [A general consideration of electronic music and the associated practical problems], April 1958; author’s collection. Translation by author; for original quote, see Appendix.

129. Technische Hogeschool Delft was founded as a royal academy in 1842 and became a polytechnic in 1864. The academic level of the technical education provided by the school was acknowledged in 1905, and it became a *technische hogeschool*, or institute of technology. It became Delft University of Technology in 1986.
130. Ibid. Translation by author; for original quote, see Appendix.
131. Ibid.
132. H. Badings, *Enige opmerkingen over importantie, urgentie en doelstelling van een electronische studio* [Some remarks on the importance, urgency and purpose of an electronic studio], April 1958; author's collection. Translation by author; for original quote, see Appendix.
133. Ibid. Badings was obviously referring here to the "ambiophonic" reproduction of his electronic ballet *Kain en Abel* (see Chapter 3, 66–72). Translation by author; for original quote, see Appendix.
134. Minutes of the CEM assembly of December 12, 1957; author's collection.
135. Minutes of the CEM assembly of October 15, 1958; author's collection.
136. Minutes of the CEM assembly of December 12, 1958; author's collection.
137. According to an article in the newspaper *Utrechts Nieuwsblad*, April 6, 1960: 2, the construction of a new building for the Physics Laboratory would start around April 1, 1961.
138. Letter from Reeser and Endt to Des Tombe of 28 November 1958, copy in author's collection.
139. Minutes of the assembly of CEM on 10 April 1959, author's collection.
140. Minutes of the CEM assembly of November 19, 1959; author's collection.
141. Letter from Escher to Schat, November 27, 1960, in Voermans, *Peter Schat – Rudolf Escher*, 110: "Ik beschouw dit als een welkome gelegenheid om alvast eens als 'elektronisch componist' voor de dag te komen, mede in verband met 'zekere' plannen."
142. In Voermans, *Peter Schat – Rudolf Escher*, 168, it is mentioned that Escher was referring to plans for a third symphony for two orchestras and four electronic tracks.
143. H. Mol, *Geloof en bijgeloof in de fonetiek* [Faith and superstition in phonetics] (The Hague: Mouton & Co, 1960), 3.
144. R. Escher, "Notities voor 1e gesprek met Prof. H. Mol op 8 december 1959" [Notes for first meeting with Prof. H. Mol on December 8, 1959]; Netherlands Music Institute.
145. R. Escher, "Studio's voor elektronische muziek en experimenteel musicologisch onderzoek in universitair verband" [Studios for electronic music and experimental musicological research in a university context], June 1960, 3; typescript at Netherlands Music Institute.
146. R. Escher, "Notities voor 1e gesprek met Prof. H. Mol op 8 december 1959" [Notes for first meeting with Prof. H. Mol on December 8, 1959]; Netherlands Music Institute.
147. R. Escher, "Notities voor 2e gesprek met Prof. H. Mol op 11 december 1959" [Notes for second meeting with Prof. H. Mol on December 11, 1959]; Netherlands Music Institute.
148. Letter from Escher to Mol, December 17, 1959; Netherlands Music Institute.
149. Mol, *Geloof en bijgeloof*, 26: "De fonetische wetenschappen brengen ons in aanraking met een breed gebied. Zij vormen een vak waar zelfs muziek in zit." In Dutch, the expression "waar muziek in zit" also means "that has a future."
150. Jaap Vink later became an important staff member at the Institute of Sonology and remained in that position until his retirement in 1993.
151. Minutes of the CEM assembly of July 14, 1960; author's collection.
152. Radio Verkehrs AG, the precursor of Österreichischer Rundfunk [Austrian Broadcasting]. The RAVAG tape machines were in fact identical to the WIRAG ones used in the Philips studio.
153. Minutes of the CEM assembly of August 26, 1960; author's collection.
154. Minutes of the CEM assembly of June 12, 1961; author's collection.
155. Minutes of the CEM assembly of July 17, 1961; author's collection.
156. Minutes of the CEM assembly of October 5, 1961; author's collection.
157. Minutes of the CEM assembly of October 5, 1961; author's collection.
158. Frits Weiland moved from the Nederlandse Televisie Stichting [Dutch Television Foundation] to STEM in May 1961. Like Jaap Vink, Weiland would remain a permanent staff member of the Institute of Sonology until his retirement in 1990. Weiland in particular deserves recognition for his longterm commitment to the Institute of Sonology's tape archive from the beginning of his career at STEM / the Institute of Sonology.
159. Utrecht University press release for a press conference held on June 12, 1961; author's collection.
160. Ibid.: "Henk Badings, die door zijn vaardigheid en fantasie de stimulans is geweest die de Philips-studio deed ontstaan."
161. Herbert Eimert, *Lehrbuch der Zwölfontechnik* [Twelve-tone technique study book] (Wiesbaden: Breitkopf & Hartel, 1952).
162. Hanns Jelinek, *Anleitung zur Zwölftonkomposition* [Guide to twelve-tone composition] (Vienna: Universal Edition, 1952).
163. The undated manuscript of this composition and the parts were discovered in Tom Dissevelt's study on August 20, 2002, when Dick Raaijmakers and the author visited Rien Dissevelt-Reys in the Dutch town of Soest.
164. The tape of these takes was found in the attic of Dissevelt's house in Soest in June 2003. The takes were combined according to the previously discovered manuscript. The complete work is available on *Popular Electronics: Early Dutch Electronic Music from Philips Research Laboratories*, Basta Music 30.9141.2. (2004). The score was published as *12-toons compositie voor the Skymasters* (Amsterdam: Donemus, 2007).
165. Letter from Raaijmakers to Miep Roggen, December 25, 1960: "worden ingenomen als een pil." Author's collection.

166. Letter from Raaijmakers to Miep Roggen, February 2, 1961: "Volledig losstaan van welke gedragingen van objecten in de natuur dan ook!" Author's collection.
167. Letter from Raaijmakers to Miep Roggen, February 14, 1961; author's collection.
168. Letter from Raaijmakers to Miep Roggen, March 6, 1961: "groei naar de beeldende kunst toe en van de muziek af is niet meer te ontkennen duidelijk." Author's collection.
169. Letter from Raaijmakers to Gerrit Borgers, September 26, 1962; author's collection.
170. CD booklet for *The Complete Tape Music of Jan Boerman*, CV-NEAR 04/05/06/07/08, 38.
171. *Ibid.*, 46–8.
172. Letter from Escher to Kok, October 4, 1957; author's collection.
173. Booklet for a CD of music by Rudolf Escher, NM Classics 92048, 3–5.
174. Rudolf Escher, notebook 1, "Elektronische muziek, onderzoekingen en werknottities" [Electronic music: Research and working notes]; Netherlands Music Institute.
175. Rudolf Escher, in a handwritten overview of events related to his plans for electronic music studios: "Op woensdag 12 juli 1961 v.m. gesprek met Des Tombe en zijn vraag of ik de leiding van een tweede studio op mij zou willen nemen." [Wednesday, July 12, 1961, this afternoon, conversation with Des Tombe; he asked if I would accept a position as head of a second studio.]
176. Draft of a letter from Escher to Spek, November 28, 1961; Netherlands Music Institute collection.
177. Letter from Raaijmakers to Miep Roggen, June 21, 1961; author's collection: "Het conflict met Vermeulen neemt toe." [The conflict with Vermeulen is growing.]
178. Copy sent to Vermeulen of a letter from Bomli to Des Tombe, October 10, 1961, PCA NL 163: "feiten en symptomen te noemen, waaruit mij enigermate duidelijk wordt, hoe de hoogst ongezonde toestand tussen beide heren ontstaan is."
179. *Ibid.*: "de heer R. heeft in overspannen toestand gehandeld en gesproken, òf hij heeft zich hoogst ondisciplinair gedragen."
180. *Ibid.*: "gezagscrisis"
181. *Ibid.*: "werkt onder het gezag van Ir. Vermeulen en zich dienovereenkomstig te gedragen heeft."
182. *Ibid.*: "niet bekwaam, om de functie van muzikaal leider te vervullen."
183. *Ibid.*: "is er in heel Nederland maar één man, muzikaal en technisch bekwaam voor die functie, nl. Henk Badings."
184. R. Vermeulen, "Aantekening voor een bespreking op 11 oktober 1961 in Eindhoven met prof. dr. H. B. C. Casimir en mr. J. H. des Tombe" [Notes for a meeting on October 11, 1961, in Eindhoven with Prof. H. B. C. Casimir and Mr. J. H. des Tombe], PCA NL 163: "gelukt is om zowel Badings als Vermeulen er uit te werken, en nu zijn plan kan uitvoeren om een kleine groep gelijkgezinde componisten om zich heen te verzamelen."
185. *Ibid.*: "beschouwd worden als de eigenlijke leider van de studio [...] omdat Escher niet alleen technisch maar ook muzikaal geheel van hem afhankelijk is."
186. *Ibid.* Translation by author; for original quote, see Appendix.
187. *Ibid.* Translation by author; for original quote, see Appendix.
188. *Ibid.* Translation by author; for original quote, see Appendix.
189. Minutes of the CEM assembly of June 12, 1961; author's collection.
190. Frank Steijns, "Henk Badings (1907–1987): biografie & stijl; analyse van zijn vioolconcerten; bespreking van zijn pedagogische vioolwerken" [Henk Badings (1907–1987): Biography & Style; Analysis of his violin concertos; Discussion of his pedagogical works for violin] (PhD dissertation, Lemmensinstituut, Leuven, Belgium, 1994), 20.
191. Draft of a letter from Escher to Casimir, November 8, 1961: "een studio voor elektronische muziek onder leiding van een man die al jaren lang even hardnekkig en verbeten streeft naar zijn doel: een Badings-suprematie in de Nederlandse elektronische muziek." Netherlands Music Institute collection.
192. *Ibid.* Translation by author; for original quote, see Appendix.
193. *Ibid.*: "oetmoedig kloppen op de machtige poorten van techniek, industrie en radio-omroep. Die toegang werd en wordt meestal wel verleend, maar blijkbaar onder voorbehoud dat de technische mens een beetje mag lachen om de halfgare kunstenaar."
194. *Ibid.*: "vormt een indrukwekkend totaal aan mathematisch en fysisch intellect."
195. *Ibid.* Translation by author; for original quote, see Appendix.
196. *Ibid.*: "het dient een volkomen autonoom instituut te worden waar eigen richtlijnen, niet doorkruist door inmenging van anderen, kunnen worden ontwikkeld."
197. *Ibid.*: "op artistieke en morele gronden volstrekt onaanvaardbaar."
198. *Ibid.*: "dat ik bij dit onderzoek aan heel andere dingen denk dan bv. aan het ontwikkelen van een apparaat dat langs elektro-akoestische weg 20 violen zou kunnen vervangen." Escher was obviously referring to Vermeulen's *Philolist* loudspeaker violins (see Chapter 1, 36–8).
199. *Ibid.*: "technische padvinderij."
200. *Ibid.*: "nooit enige aanvechting gehad om het artistieke credo of zelfs maar de mentaliteit van de Heer Badings te bestrijden." "suprematie van dat credo en van die mentaliteit steeds dichter STEM naderen."
201. *Ibid.*: "laat  $\alpha$  en  $\beta$  nu snel – zeer snel – bijeenkomen om te overleggen op welke wijze tenminste aan een tweede studio een start gegeven zou kunnen worden"
202. Letter from Escher to Des Tombe, November 27, 1961; Netherlands Music Institute collection.
203. Letter from Escher to Schat, December 19, 1959, in Erik Voermans, ed., *Peter Schat – Rudolf Escher – brieven 1958–1961* (Zutphen: Walburg Pers, 1992), 98–9.
204. According to the liner notes of the double LP *Anthology of Dutch Electronic Tape Music, Volume 1: 1955–1966* (Amsterdam: Donemus, Composer's Voice CV 7803), *Studie* was performed frequently at first but was later



- withdrawn. *Studie* by Schat is mentioned in Hugh Davies, ed., “International Electronic Music Catalog,” *Electronic Music Review* 2/3 (1967): 120, but its duration is unknown.
205. Letter from Schat to Escher, January 3, 1960, in Voermans, *Peter Schat – Rudolf Escher*, 101–2.
206. Letter from Raaijmakers to Miep Roggen, June 20, 1961; author’s collection.
207. Copy sent to Raaijmakers of a letter from Spek to Des Tombe, August 21, 1961: “musicologische achtergronden en het bestaan van niet meer weg te denken composities rechtvaardigen de stichting van een studio.” “De onverenigbaarheid van hooggespannen verwachtingen met onderschatting der opgaaf heeft in Delft zowel als in Utrecht tot een moeizame gang van zaken aanleiding gegeven.” Author’s collection.
208. *Ibid.*
209. Letter from Raaijmakers to Miep Oddens-Roggen, October 30, 1961; author’s collection.
210. Jan Vrijman, *De werkelijkheid van Karel Appel* [The reality of Karel Appel] (Amsterdam: De Bezige Bij, 1962), 37: “een equivalente muziek, die evenals zijn schilderijen door alle gangbare begrippen heen zou breken.”
211. Appel had worked in Paris since the early 1950s and presumably had heard of *musique concrète* there.
212. *Ibid.*: “met zijn creatieve kracht en moed een anti-muziek zou kunnen produceren, die stellig beter bij de film zou passen dan welke muziek van welke Nederlandse componist dan ook.”
213. Dick Raaijmakers, “Elektronische muziek in Nederland: geen componisten, geen studio’s, wel opleidingen” [Electronic music in the Netherlands: No composers, no studios, but courses]. Unpublished article, October 9, 1962; author’s collection.
214. Minutes of the CEM assembly of December 20, 1962; author’s collection.
215. Letter from Koenig to Maas, June 22, 1961; Koenig’s private collection.
216. Minutes of the CEM assembly of July 17, 1961; author’s collection.
217. G. M. Koenig, *Ästhetische Praxis: Texte zur Musik: Band 1, 1954–1961* [Aesthetic practice: Texts on Music: Volume 1, 1954–1961] (Saarbrücken: Pfau Verlag, 1991), 224–97.
218. *Zwanzig Jahre Musik im Westdeutscher Rundfunk* [Twenty years of music at Westdeutscher Rundfunk] (Cologne: Westdeutscher Rundfunk Köln, 1968), 103. Other compositions on the program were: Bengt Hambreus’ *Doppelrohr II*, Hermann Heiß’s *Elektronische Komposition I*, Giselher Klebe’s *Interferenzen*, Herbert Eimert’s *Fünf Stücke* and Ernst Krenek’s *Spiritus Intelligentiae Sanctus*.
219. Lecture by Koenig at the Institute of Sonology, The Hague, May 28, 2007. Koenig later added that another reason to produce *Essay* in mono was that spatiality had played no role in its compositional conception.
220. Koenig, *Ästhetische Praxis: Texte zur Musik: Band 1*, 253: “Zweifellos kommt die Modernität eines Werks nicht einfach dadurch zustande, daß es mit [...] räumlichen Konstellationen operiert.”
221. *Ibid.*, 258. Translation by author; for original quote, see Appendix.
222. *Ibid.*, 258–59. Translation by author; for original quote, see Appendix.
223. *Ibid.*, 259–60. Translation by author; for original quote, see Appendix.
224. *Ibid.*, 261: “die Hörer fühlten sich von den Lautsprechern wie von Maschinengewehren umzingelt.” In a conversation with the author on October 20, 2012, Koenig said this statement must have come from a *Kölnische Stadtanzeiger* newspaper review of the aforementioned May 30, 1956, concert.
225. *Ibid.*, 261: “er möchte auf das sich konzentrieren, was er hören möchte, und nicht widerstandslos einem Geschehen ausgeliefert sein.”
226. Minutes of the CEM assembly of April 5, 1962; author’s collection.
227. Minutes of the CEM assembly of May 22, 1962; author’s collection.
228. Letter from Koenig to Maas, May 13, 1962; Koenig’s private collection.
229. Minutes of the CEM assembly of July 16, 1962; author’s collection. The 1962 Summer Course ran from July 8 to 20.
230. Minutes of the CEM assembly of October 10, 1962; author’s collection.
231. G. M. Koenig, *Ästhetische Praxis: Texte zur Musik: Band 2, 1962–1967* (Saarbrücken: Pfau Verlag, 1992), 56–57: “damit jeder, wenigstens theoretisch, an ihnen teilhabe; er, Stockhausen, arbeite zugleich stellvertretend für seine Kollegen.”
232. *Ibid.*, 57: “vielmehr setzt sie die bisherige Arbeitsteilung zwischen Komponist und Interpret außer Kraft; sie zeigt zudem, daß der musikalische Ton kein unteilbares Element ist.”
233. *Ibid.*, 58–9.
234. Minutes of the CEM assemblies of October 10 and December 20, 1962; author’s collection.
235. Electronically operated tone gates had been available in the studios in Eindhoven and Delft from 1956 and 1957 respectively; see previous chapters.
236. See assignment 3 for the Bilthoven electronic music course, 1964–1965, as printed in G. M. Koenig, *Ästhetische Praxis: Texte zur Musik: Band 5, Supplement II* (Saarbrücken: Pfau Verlag, 2002), 56.
237. *Ibid.*, assignments 7 and 13, 61–2.
238. Ramon Zupko, e-mail message to the author, December 2, 2004. Zupko was a 1965–1966 Bilthoven course participant.
239. Koenig’s Bilthoven course ran four times between 1962 and 1966. Compositions that resulted from the course’s assignments and are available for listening are *BTH. 3457* (1963), by Will Eisma (\*1929); *K45* (1964–1965) and *VG56* (1965–1966), by Klaus Gorter; *Etude I* (1964–1965), by Luctor Ponce (1914–1998); *Polychromie I* (1965–1966), by Berend Giltay (1910–1975); and *Transients* (1965–1966), by Ramon Zupko (1932–2019). In 2001, the author created a composition based on the Bilthoven assignments entitled *K12*.

240. Letter from Koenig to Dr. Horst, cultural attaché of the German embassy in the Netherlands, July 1, 1963; Koenig's private collection.
241. "Henk Badings naar Australië," *Utrechts Nieuwsblad*, March 30, 1962: 7.
242. "Ir. H. Badings hoogleraar in Stuttgart" [H. Badings professor in Stuttgart], *Utrechts Nieuwsblad*, October 30, 1962: 5: "temeer omdat de elektronische studio in wording zijn werk is geweest."
243. Ibid.
244. Steijns, "Henk Badings (1907–1987)," 20.
245. "Situatie ir. Badings aan universiteit" [Situation of Badings at the university], *Utrechts Nieuwsblad*, December 11, 1962: 5.
246. The *Three Lucebert Songs* for male choir and tape were also released in a transposed version as *Drei Schwärmereien* for mixed choir and tape.
247. Letter from Koenig to Bomli, May 5, 1963; Koenig's private collection.
248. Letter from Koenig to Des Tombe, May 5, 1963; Koenig's private collection.
249. Letter from Escher to J. H. Schuringa, July 13, 1962; Netherlands Music Institute collection.
250. R. Escher, "Notities over een studio voor elektronische muziek, eventueel in verband met experimenteel musicologisch onderzoek" [Notes on a studio for electronic music, possibly connected with experimental musicological research], November 1963, 1: "Men dient echter geen ogenblik te vergeten dat dit bijzondere laboratorium primair in dienst staat van een bijzondere vorm van artistieke creativiteit, te weten: de muzikale compositie, een discipline dus die geheel valt binnen de culturele sfeer." Netherlands Music Institute collection.
251. Ibid.: "in dienst staat van een bijzondere vorm van zuiver wetenschappelijk onderzoek, nl.: muziekfenomenologie."
252. Ibid.: "elektrotechniek, amusementsmuziek en negotie."
253. Ibid., 7.
254. Ibid., 8: "Afgedankte scholen of andere vervallen gebouwtjes, waarvoor universiteiten in onze welvaartsstaat altijd nog zoveel voorkeur vertonen, zijn ongeschikt voor de huisvesting van een elektronisch klanklaboratorium. Werkelijke geluidsisolatie is daarin bijna nooit aan te brengen. Stille en rust zijn een primaire eis."
255. Ibid., 12: "Een tegenwicht tegen de Duitse suprematie in de nieuwe muziektheorieën lijkt mij zeer gewenst!"
256. Geoffrey Madge, in an e-mail message to the author, November 3, 2012, and a conversation with the author, November 15, 2012.
257. Among that group of students were Axel Meijer (\*1940), Robbert-Jan de Neeve (\*1940) and Paul Op de Coul (\*1940).
258. Frits Weiland, in conversation with the author, October 6, 2012.
259. Caspar Becx, *Henk Badings' symfonische blaasmuziek* [Henk Badings' music for wind orchestra] (Utrecht: Stichting NIB, 1993), 126. The *Pittsburgh Concerto* premiered on July 10, 1965, in Pittsburgh; *ibid.*, 125.
260. Frits Weiland, in conversation with the author, October 6, 2012.
261. Escher, "Studio's voor elektronische muziek," 3: "ruimtevaart-romantiek."
262. Liner notes for Tom Dissevelt's *Fantasy in Orbit*, Philips 633 302 BL.
263. Letter from Koenig to Dr. Horst, cultural attaché of the German embassy in the Netherlands, July 1, 1963; Koenig's private collection.
264. Nowadays, however, *Fantasy in Orbit* is a highly collectable LP that has achieved cult status.

## Chapter 11 Private Projects

265. W. A. L. Beeren et al., ed., *Actie, werkelijkheid en fictie in de kunst van de jaren '60 in Nederland* [Action, reality and fiction in 1960s art in the Netherlands] (Rotterdam: Museum Boijmans Van Beuningen, 1979), 35.
266. Voermans, *Peter Schat – Rudolf Escher*, 39: "de bestaande grenzen tussen muziek, theater en beeldende kunst op te heffen, door middel van multi-media projecten en concerten."
267. Beeren, *Actie, werkelijkheid en fictie*, 35: "om bij de toekomstige bouw van schouwburgzalen rekening te houden met de ontwikkelingen die in de twintigste eeuw hebben plaatsgevonden."
268. Voermans, *Peter Schat – Rudolf Escher*, 39: "volslagen onzinnig."
269. Beeren, *Actie, werkelijkheid en fictie*, 35: "de theatervorm is blijven steken in het renaissance model van kijkkast toneel."
270. Ibid. Translation by author; for original quote, see Appendix.
271. Minutes of the CEM assembly of February 9, 1962: "een groepje personen, die elkaar toevallig gevonden hebben." Author's collection.
272. Ibid.: "De secretaris zal de MES antwoorden, dat een bespreking in de vergadering van 9 Februari 1962 geen perspectieven voor samenwerking heeft opgeleverd."
273. Invitation to the MES concert on February 1, 1962; author's collection.
274. "Nieuw experimenteel muzikaal theater gedemonstreerd – De M.E.S. in De Lantaren" [New experimental music theater demonstrated: M.E.S. at De Lantaren], *Nieuwe Rotterdamse Courant*, February 2, 1962: 5.
275. Leaflet giving program details of the MES events; author's collection.
276. Voermans, *Peter Schat – Rudolf Escher*, 39.
277. Letter from Raaijmakers to Miep Oddens-Roggen, February 28, 1962; author's collection.
278. Voermans, *Peter Schat – Rudolf Escher*, 39.
279. Letter from Spek to Kok, April 10, 1963: "alles wat ik leerde en doorwerkte om deze belangrijke opdracht te kunnen aanvaarden in Delft en alleen daar zijn oorsprong heeft." Author's collection.

280. Spek corresponded with Raaijmakers on a regular basis. The last letter from Cologne is dated May 9, 1966, and the first postcard from the US July 13, 1967. In a letter to Miep Oddens-Roggen dated July 10, 1967, Raaijmakers mentions that Spek was to leave for the US the next day.
281. Postcard from Spek and Higgins to Raaijmakers, July 14, 1967: “de enige originele muziekdenker die NL bezit.” Author’s collection.
282. Entry in the STEM datebook for February 16, 1962: “Jan Boerman komt zijn materiaal bijeenzoeken” [Jan Boerman comes to collect his materials], Institute of Sonology archive.
283. Letter from Escher to J. H. Schuringa, July 13, 1962, and letter from Raaijmakers to Escher, October 23, 1962; Netherlands Music Institute collection.
284. Letter from Raaijmakers to Miep Oddens-Roggen, October 9, 1962; author’s collection.
285. Letter from Raaijmakers to Escher, October 23, 1962: “de Duitse invasie in Bilthoven naast Badings’ positie nu in Utrecht.” Netherlands Music Institute collection.
286. Letter from Raaijmakers to Miep Oddens-Roggen, November 21, 1962; author’s collection.
287. Letter from Raaijmakers to Miep Oddens-Roggen, February 14, 1963; author’s collection.
288. Ibid.
289. Wolfgang Wijdeveld, “Een compositie voor elektronische klanksporen en orgel van Ton Bruynèl” [A composition for electronic soundtracks and organ by Ton Bruynèl], *Mens en Melodie* 4 (1965): 111: “De piano gebruikte hij slechts om in contact te komen met de door hem geliefde componisten, van wie Bach wel de voornaamste was.”
290. Kees van Baaren was director of the Utrechts Conservatorium from 1953 to 1956.
291. CD booklet for *Ton Bruynèl: Looking Ears Complete* (Amsterdam: Muziekgroep Nederland, CV-NEAR 12), 3.
292. “Vernissage met muzikale opluistering” [Vernissage with musical adornment], *Utrechts Nieuwsblad*, March 10, 1956: 4. The scherzo was not played live but on a tape machine.
293. Ibid.: “waarbij men een speciaal klankeffect als een grondgedachte kan gebruiken, als een zekere kiem.”
294. *Ton Bruynèl: Looking Ears Complete*, 3.
295. Bruynèl’s studio was located at Schalkwijkstraat 8.
296. “Kunstenaarsateliers in Schalkwijkstraat open: Goede bestemming voor bouwvallige huisjes” [Schalkwijkstraat artists’ studios open: Good use of crumbling houses], *Utrechts Nieuwsblad*, December 16, 1961: 5.
297. Letter from Raaijmakers to Miep Oddens-Roggen, February 20, 1961; author’s collection.
298. “Utrechtse componist werkt aan ballet” [Utrecht composer works on ballet], *Utrechts Nieuwsblad*, July 24, 1962: 5.
299. Although the studio in Delft officially closed on September 1, 1960, some composers were allowed to continue working there. Escher made *The Long Christmas Dinner* in November–December 1960, and Boerman worked there until December 23, 1961. Wijdeveld wrote in *Mens en Melodie* 4 (1965): 112 that parts of *Resonance I* were made there with Spek’s assistance. This is confirmed by Davies in “International Electronic Music Catalog,” 123. *Resonance I* does sound as if the studio’s Bruel & Kjaer third-octave filter was used in it. In a letter from Kok to J. Oldmeadow dated September 24, 1964, Kok writes that “the activities on electronic music in this laboratory have been ended since 1962.” Author’s collection.
300. “Utrechtse componist werkt aan ballet” [Utrecht composer works on ballet], *Utrechts Nieuwsblad*, July 24, 1962: 5.
301. “*Résonance* van Ton Bruynèl resonanceert niet” [Ton Bruynèl’s *Resonance* does not resonate], *Utrechts Nieuwsblad*, November 15, 1962: 4. Translation by author; for original quote, see Appendix.
302. “Utrechtse componist werkt aan ballet,” *Utrechts Nieuwsblad*, July 24, 1962: 5.
303. Ibid.
304. “*Resonance II* van Ton Bruynèl in Amsterdam,” *Utrechts Nieuwsblad*, March 24, 1964: 5: “Poëzie en muziek zijn in deze collage letterlijke zin uit elkaar voortgekomen, ook dáár waar ze op zichzelf staand en onvermengd zijn gebleven.”
305. “Bruynèl’s *Resonance* in Stedelijk Museum,” *Utrechts Nieuwsblad*, April 10, 1964: 6. The speakers that reproduced the seventeen-minute *Collage Resonance II* were mounted in a large cube in the center of one of the museum’s galleries; parts of Kouwenaar’s text were printed on the cube’s surface. The walls were covered with a strip of black cloth with benches placed below it.
306. “Ton Bruynèl: De tijd is erin opgesloten” [Ton Bruynèl: Time is captured in it], *Utrechts Nieuwsblad*, April 8, 1964: 5: “Het vervormen, het kapotmaken van stemmen vind ik uit den boze. Het is niet eerlijk”; “Het getuigt van weinig respect voor het eigene van de uitvoerders.”
307. On March 3, 1945, the center of Beuzidenhout in The Hague was bombed by mistake when Allied forces tried to destroy a V2 rocket-launching site in the nearby Haagse Bos (The Hague forest).
308. Frits Cordess, in conversation with the author, The Hague, November 1, 2012.
309. Cordess could not give the year in which Boerman took over from Feenstra, but Boerman was first listed in the telephone book at Daendelsstraat 80 in 1954. Feenstra was still listed at the address in 1953.
310. Frits Cordess, in conversation with the author, The Hague, November 1, 2012.
311. Letter from Boerman and Raaijmakers to Kok, March 14, 1963; author’s collection.
312. Daendelsstraat 47.
313. Letters from Raaijmakers to Miep Oddens-Roggen, September 3 and 15, 1963; author’s collection.
314. Letters from Raaijmakers to Miep Oddens-Roggen, January 24, 1964; author’s collection.
315. Karlheinz Stockhausen, *Nr. 12 – Kontakte – Elektronische Musik – Realisationspartitur* (London: Universal Edition, 1968).
316. Letter from Spek to Raaijmakers, November 25, 1963; author’s collection.

317. Spek brought the material without Stockhausen's permission. Raaijmakers copied the tape immediately and frequently used it in later years when discussing *Kontakte* in lessons at the Royal Conservatoire.
318. Letter from Raaijmakers to Miep Oddens-Roggen, December 11, 1963: "Iedere ademhaling, iedere stap heeft bij hem direct betekenis. Zijn hele leven is een aaneengesloten muzikale daad." Author's collection.
319. Letter from Raaijmakers to Miep Oddens-Roggen, February 16, 1964; author's collection.
320. Karlheinz Stockhausen, "...wie die Zeit vergeht..." *die Reihe* III (1957).
321. Letter from Raaijmakers to Miep Oddens-Roggen, March 15, 1964; author's collection. For original quote, see Appendix.
322. Ibid.: "Ver weg vliegend veroorzaakt het geluiden die steeds veranderen en anders zijn met toch steeds een niet veranderende geluidsbron, b.v. de straalturbines."
323. Ibid.: "zodanig te componeren dat het definitieve geluid – het exemplaar geluid – zó veranderbaar is, nadat het de luidspreker heeft verlaten [...], dat van een nieuwe reeks geluiden sprake is geworden die het ene exemplaar heeft veroorzaakt."
324. Ibid.: "staten van morfititeit van dat oorspronkelijke geluid."
325. Ibid. Translation by author; for original quote, see Appendix.
326. Ibid.
327. Letter from Raaijmakers to Spek, January 6, 1964; author's collection. Translation by author, for original quote, see Appendix.
328. Letter from Raaijmakers to Miep Roggen, February 2, 1961; author's collection.
329. The Hall of Illusions was part of the Paris World's Fair of 1900. It featured electrical illuminations and various systems of suspension for mirrors and lights that created spectacular lighting effects.
330. Letter from Raaijmakers to Spek, September 30, 1963; author's collection.
331. Dick Raaijmakers, "Schema 3: Konstruktie van Kompositie" [Scheme 3: Construction of composition], unpublished typescript, 8; author's collection.
332. These experiments are described in detail in a letter from Raaijmakers to Spek of December 22, 1963 (author's collection). Repeating them in a digital environment actually showed that the sonic richness Raaijmakers achieved was partly caused by the inaccuracy of the analogue tape recorders he used. Small fluctuations in tape speed caused phasing effects that contributed to the quality of the sounds and brought the results closer to open-air sonic phenomena, such as the airplane and bell tower examples, where phasing effects occur due to the movements of the sound sources and the fact that the sound waves travel through air that fluctuates.
333. Dick Raaijmakers, in conversation with the author, The Hague, August 23, 2012.
334. Dick Raaijmakers, *Cahier "M": A Brief Morphology of Electric Sound*, Richard Barrett, trans. (Leuven: University Press, Revised edition 2005), 96–7.
335. Wijdeveld, "Een compositie voor elektronische klanksporen en orgel," 112.
336. From Ton Bruynèl's score *Reliëf* (Amsterdam: Donemus, 1964).
337. Wijdeveld, "Een compositie voor elektronische klanksporen en orgel," 113.
338. In Wijdeveld's article, "Een compositie voor elektronische klanksporen en orgel," 112, the author claims that the score of *Reliëf* is the first of its kind in the Netherlands, but this is questionable. De Leeuw had already used a graphical notation for the electronic parts in his *Antiphonie* (1960) for wind quintet and four sound tracks (published by Donemus, Amsterdam), and graphical notation for instruments had been used by Misha Mengelberg (*Exercise* for flute, 1961) and Louis Andriessen (*Paintings* for flute and piano, 1961). Both works had been performed during the MES concerts in February 1962. Bruynèl's *Reflexen* was performed during the MES concerts too.
339. That team included Gottfried Michael Koenig.
340. Dick Raaijmakers, in conversation with the author, August 23, 2012.
341. Letter from Raaijmakers to Miep Oddens-Roggen, March 15, 1964; author's collection.
342. See for instance: Karlheinz Stockhausen, *Nr. 12 – Kontakte – Elektronische Musik – Realisationspartitur* (London: Universal Edition, 1968), 12–3. The technique was later used widely in pop music recordings, and several pop recording engineers have been wrongly credited with its invention (such as Ken Townshend, working for the Beatles; George Chkiantz, working for the Small Faces; and Eddie Kramer, working for Jimi Hendrix).
343. Letter from Raaijmakers to Miep Oddens-Roggen, April 20, 1964. Author's collection. Translation by author, for original quote, see Appendix.
344. For *De Zee*, Boerman used a sequence that started with 1, 3, 4, 7, 11, 18 and so on. Although he refers to this sequence as a Fibonacci sequence, it is in fact a Lucas sequence. Nevertheless, the golden ratio is approached effectively through a Lucas sequence as well. The Fibonacci sequence is one of many Lucas sequences.
345. Since the Revox recorders in Boerman and Raaijmakers' studio ran at a speed of 19.05 cm/sec, 1 cm of tape equaled 1/19.05 of a second. In later compositions, 1 cm of tape equaled 1/38.1 of a second.
346. CD booklet for *The Complete Tape Music of Jan Boerman*, CV-NEAR 04/05/06/07/08, 52.
347. Ramón Gieling and Michel Waisvisz, "Een bescheiden ontketening" [A modest chain reaction], *Wolfsmund* 13/14 (1985): 131.
348. Sleeve insert for the record of Jan Boerman's *Composition 1972 / Alchemie 1961 / De Zee*; Composer's Voice CV 7701, Donemus.
349. Voeten, *Holland Festival*, 180.
350. Sleeve insert for the record of Jan Boerman's *Composition 1972 / Alchemie 1961 / De Zee*; Composer's Voice CV 7701, Donemus. *Monument voor een gestorven jongen* was performed on Broadway in 1967, in New York by the Harkness Ballet in 1968, in Copenhagen in 1974, in Toronto in 1975, in Berlin by the Deutsche Oper in 1976, etc.

## Chapter 12 Towards Stability in Utrecht and The Hague

351. "Situatie ir. Badings aan universiteit," *Utrechts Nieuwsblad*, December 11, 1962: 5.
352. Letter from Koenig to Bomli, May 5, 1963; Koenig's private collection.
353. This edition of the International Summer Course for New Music took place from June 22 to July 10.
354. G. M. Koenig, *Ästhetische Praxis: Texte zur Musik: Band 6, Supplement III* (Saarbrücken: Pfau Verlag, 2007), 7.
355. *Ibid.*, 8. The fact that this performance was part of Adorno's composition course is mentioned in the CD booklet of *50 Jahre Neue Musik in Darmstadt, Vol. 1, 12–3*.
356. Simon Emmerson, *Living Electronic Music* (Aldershot: Ashgate Publishing Limited, 2007), 76.
357. According to International Summer Course programs, the following works of *musique concrète* were performed: in 1951, *Symphonie pour un homme seule* and *Orphée 53* by Schaeffer and Henry; in 1952, *Antiphonie* by Henry, *Deux études concrètes* by Boulez, *Timbres-durées* by Messiaen, and *Maskerage* by Schaeffer; in 1953, *Maskerage* by Schaeffer and *Leonardo da Vinci* by Schaeffer and Henry.
358. Letter from Koenig to Meyer-Eppler, July 30, 1951: "dass die Musik endlich die Möglichkeit habe, wie Malerei oder Literatur der Vermittlung entraten zu können." Koenig's private collection.
359. *Ibid.*: "fest entschlossen, mit den Mitteln der elektronischen Klangerzeugung zu arbeiten, sobald sich mir die Gelegenheit dazu bietet."
360. Letter from Meyer-Eppler to Koenig, August 2, 1951; Koenig's private collection.
361. Letter from Koenig to Eimert, August 4, 1951; Koenig's private collection.
362. Letter from Koenig to Eimert, November 12, 1951: "Die neue Klangwelt erfordert eine neue Technik, oder besser: da wir Musik anders hören, sehen wir uns genötigt, zu den elektronischen Geräten zu greifen." Koenig's private collection.
363. *Ibid.* Translation by Koenig; for original quote, see Appendix.
364. Interview with Gottfried Michael Koenig by the author, Ratskeller Kalkar, Germany, February 22, 2012; digital recording.
365. Letter from Koenig to Inge Mache, April 23, 1952: "eine funkeigene und funkgerechte Kunstform, die Wort, Geräusch und Musik zu einem neuen Ganzen verschmilzt." Koenig's private collection.
366. Letter from Koenig to Cocteau, February 3, 1952: "wäre einmal ein Sprachrohr für alle, die der Kunst- 'Betrieb' nicht zu Wort kommen läßt. Zum ändern wäre es ein Experimentierplatz, ähnlich dem Club d'Essai in Paris, für die, die sich mit funkeigener Literatur und Musik beschäftigen." Koenig's private collection.
367. *Ibid.*: "welche die technischen Möglichkeiten der Übertragung und der Montage als Material benutzt."
368. "Ausdruckstanz" was a type of dance developed in Germany in the period between the two world wars in which emotion formed the immediate basis for the movements.
369. The score was later published as *Fantasie für Orchester* (1951–1952), Tonos Musikverlag, Baden-Baden, catalog no. 7487.
370. The poem is based on Wilde's experiences in prison in Reading, not far from London. It is mainly a statement against the death penalty and includes the famous sentence "Each man kills the thing he loves."
371. Letter from Koenig to Anne Thenhausen, February 5, 1952; Koenig's private collection.
372. Letter from Koenig to Cocteau, February 3, 1952; Koenig's private collection. Translation by author; for original quote, see Appendix.
373. Letter from Koenig to Cora Weinhold, February 10, 1952: "Natürlich lassen sich diese Partituren in jedem Fall besser elektronisch [...] interpretieren; aber es ist möglich, auf diese Weise auch originale Orchesterpartituren zu schreiben." Koenig's private collection.
374. Letter from Koenig to Inge Mache, April 23, 1952; Koenig's private collection.
375. Letters from Koenig to NWDR in Hamburg and RIAS in Berlin, June 14, 1952; Koenig's private collection.
376. Although the 1952 Darmstadt course did feature the *musique concrète* compositions *Timbres-Durées* (1952) by Messiaen and *Deux études concrètes* (1951–1952) by Boulez, for Koenig, the high point of this edition was the premiere of Luigi Nono's (1924–1990) *Epitaffio per Federico García Lorca No. 1: España en el Corazón* (1951) for soprano, baritone, choir, instruments and percussion, conducted by Bruno Maderna. Nono's work was performed by course participants rather than a professional ensemble, and Koenig was in the choir. The performance was such a success that it was repeated. Letter from Koenig to the Weinhold family, August 1, 1952; Koenig's private collection.
377. Letter from Koenig to Johannes M. Hönscheid (1922–2001), June 15, 1952; Koenig's private collection.
378. Letter from Koenig to the Weinhold family, August 1, 1952; Koenig's private collection.
379. Letter from Koenig to Benno Ammann, August 16, 1952, and letter to Heinz Wiens, September 6, 1952; Koenig's private collection.
380. Letter from Koenig to Anne Thenhausen, November 3, 1952. The third in the series of orchestral works and the piano concerto do not appear in Koenig's list of published works.
381. Various letters written by Koenig between December 14, 1952, and September 24, 1952; Koenig's private collection.
382. Letter from Koenig to his parents, January 23, 1954; Koenig's private collection.
383. Letter from Koenig to his parents, November 17, 1953: "zum Ausprobieren solcher Sachen." Koenig's private collection.
384. Letter from Koenig to his parents, March 24, 1954; Koenig's private collection.

385. The Tonmeistertagung is a conference that focuses on audio engineering and music production and takes place every two years. The first was held in 1949.
386. Letter from Koenig to his parents, May 5, 1954; Koenig's private collection.
387. Ibid.
388. Letter from Koenig to his parents, May 13, 1954; Koenig's private collection.
389. Letter from Koenig to his parents, July 9, 1954; Koenig's private collection.
390. Letter from Koenig to his parents, July 18, 1954; Koenig's private collection. The works Eimert referred to must have been Stockhausen's *Studie II*, Pousseur's *Seismogramme I* and Paul Gredinger's *Formanten I* and/or *II*.
391. Letter from Koenig to his parents, July 22, 1954; Koenig's private collection.
392. Koenig, *Ästhetische Praxis: Band 6*, 10.
393. G. M. Koenig, "Schichten und Varianten," in *Ästhetische Praxis: Band 5*, 240–41: "Es zeigte sich, daß durch Stapelung Gebilde entstehen, die man später nur noch als Folge klanglicher Ereignisse erlebt. Umgekehrt ist der Schluß erlaubt, daß jede Klangfolge [...] als Resultat einer Stapelung verstanden werden kann."
394. Letter from Koenig to Cocteau, February 3, 1952; Koenig's private collection.
395. Letter from Koenig to Elfriede Koenig, March 14, 1955; Koenig's private collection.
396. G. M. Koenig, "Studiotechnik," *die Reihe 1* (1955). The quote is taken from the English translation by Hans G Helms of the same article in *die Reihe: A Periodical Devoted to Developments in Contemporary Music* (fourth impression, 1965, Theodore Presser Co., Bryn Mawr, Pennsylvania): 53.
397. Koenig's *Terminus II* and *Funktionen* were produced at STEM / the Institute of Sonology in Utrecht.
398. Koenig produced Bo Nilsson's *Audiogramme* in the composer's absence using a score mailed to Cologne.
399. Letters from Koenig to Elfriede Koenig, March 6 and April 19, 1955; Koenig's private collection.
400. Letter from Koenig to Elfriede Koenig, August 2, 1955; Koenig's private collection.
401. Letter from Koenig to Elfriede Koenig, July 3, 1955; Koenig's private collection. Translation by author; for original quote, see Appendix.
402. CD booklet for *Stockhausen 3: Elektronische Musik 1952–1960* (Kürten, Stockhausen Verlag, 2001), 75.
403. Letter from Koenig to Elfriede Koenig, February 25, 1962; Koenig's private collection.
404. Herbert Eimert turned 65 on April 8, 1962.
405. It would not be until April 1, 1963, however, that Stockhausen was officially appointed as artistic director.
406. Letter from Koenig to Elfriede Koenig, June 30, 1962; Koenig's private collection.
407. Unsent letter from Koenig to Stockhausen, March 8, 1962; Koenig's private collection.
408. Letters from Koenig to Knut Wiggen, March 8 and June 30, 1963; Koenig's private collection.
409. Gottfried Michael Koenig, e-mail message to the author, January 28, 2013.
410. Morawska-Büngeler, *Schwingende Elektronen*, 19.
411. Letter from Koenig to Knut Wiggen, February 2, 1964; Koenig's private collection.
412. Koenig, *Ästhetische Praxis – Band 6*, 20.
413. Interview with Gottfried Michael Koenig by the author, Ratskeller Kalkar, Germany, February 22, 2012; digital recording.
414. Letter from Koenig to Heinz-Klaus Metzger, December 10, 1957; Koenig's private collection.
415. André Malraux was a French writer and politician. He was appointed Minister of State in 1958 and Minister of Cultural Affairs in 1959.
416. Letter from Metzger to Koenig, July 14, 1958; Koenig's private collection. Translation by author; for original quote, see Appendix.
417. Letter from Koenig to Elfriede Koenig, June 26, 1958; Koenig's private collection.
418. Fellowships at the Villa Massimo German academy in Rome are still among the most important awards for German artists abroad.
419. Gottfried Michael Koenig, e-mail message to the author, January 29, 2013.
420. Letter from Koenig to Bomli, May 5, 1963; Koenig's private collection.
421. Letter from Koenig to Des Tombe, May 5, 1963; Koenig's private collection.
422. Letter from Koenig to Casimir, June 30, 1963; Koenig's private collection. Translation by author; for original quote, see Appendix.
423. Ibid.
424. Letter from Koenig to Casimir, August 29, 1963; Koenig's private collection.
425. Letter from Koenig to Jean-Pierre Wilhelm, December 22, 1963; Koenig's private collection.
426. This is confirmed by the fact that when Reeser confidentially asked Escher on June 10, 1965, to comment on a report Koenig had written about future developments at STEM, Escher's remarks were extremely negative, and he wrote that Reeser and Des Tombe would have to choose between him and Koenig sooner or later. (Letter from Escher to Reeser, June 14, 1965; Netherlands Music Institute.)
427. Letter from Spek to Raaijmakers, January 17, 1964: "structuurgeneratoren met in- én uitgangen." Author's collection. When Spek visited Raaijmakers in The Hague in March 1964, he elaborated further on Koenig's activities. Raaijmakers was now convinced that only he, Koenig and Spek were concerned with these aspects of music. (Letter from Raaijmakers to Miep Oddens-Roggen, March 22, 1964; author's collection.)
428. The Utrecht University computer center was housed at Boothstraat 6, practically around the corner from STEM at Plompstorengracht 14–16. The Electrologica factory opened in Amsterdam in 1956, and Jan de Bruyn, the former assistant of Badings and Varèse, was employed there after he left Philips' ELA division. Electrologica moved to Rijswijk, near The Hague, in 1964, as did De Bruyn. Electrologica was bought by Philips in 1968 and renamed Philips-Electrologica.



429. Letter from Koenig to Boehmer, May 8, 1965; Koenig's private collection.
430. Letter from Koenig to Boehmer, October 2, 1965; Koenig's private collection.
431. The large majority of Koenig's instrumental works from 1966 to 2013 were composed using Project 1.
432. Letter from Koenig to Boehmer, December 18, 1965; Koenig's private collection.
433. Letter from Koenig to Boehmer, December 27, 1965; Koenig's private collection.
434. Bob Malmberg, "Muziek beheerst leven van Gottfried Koenig" [Music dominates life of Gottfried Koenig], *Nieuw Utrechts Dagblad*, August 26, 1967.
435. The last electronic music course in Bilthoven hosted by STEM took place from October 7, 1966, to June 23, 1967. After that, the Bilthoven studio continued to operate independently of STEM. (Brochure, Contactorgaan Elektronische Muziek, after 1967, 7.)
436. Rijksuniversiteit Utrecht, "Profielschets van het Instituut voor Sonologie" [Profile of the Institute of Sonology], June 1977. The word "Sonology" first appears in Koenig's June 1965 internal report "De inrichting van een Laboratorium voor Sonologie" [The installation of a laboratory for sonology]; Escher collection, Netherlands Music Institute.
437. "Utrechtse studio nam nieuwe ruimten in gebruik: Computer helpt componist bij productie van muziek" [Utrecht studio occupies new rooms: Computer helps composers to produce music], *Philips Koerier*, October 28, 1967, 9.
438. Badings took instrumentation lessons from Willem Pijper in 1930 (see Chapter 3, 64–6).
439. Samama, *Zeventig jaar Nederlandse muziek*, 219.
440. Kees van Baaren, quoted in Monnikendam, *Nederlandse componisten*, 181: "week het klinkende materiaal los van de hiërarchische ordening der tonale functies. De emotionele associaties die dezen in de loop der tijden verworven hebben staan onbevangen gezichtspunten in de weg."
441. Samama, *Zeventig jaar Nederlandse muziek*, 215.
442. Kees van Baaren, quoted in John Kasander, *150 jaar Koninklijk Conservatorium: Grepen uit de geschiedenis* [150 years Royal Conservatoire: Selections from the history] (The Hague: Koninklijk Conservatorium, 1976), 114. "een zuiver technisch procédé dat de componist gelegenheid geeft het toonmateriaal dat in de loop van de 19e eeuw steeds sterker psychisch-associatief werd belast, te herontdekken als klank zonder meer."
443. Escher, "Studio's voor elektronische muziek en experimenteel musicologisch onderzoek," 7.
444. Van Baaren's composition students Misha Mengelberg, Peter Schat, Jan van Vlijmen and Maarten Bon were working in the studio in Delft at that time.
445. Minutes of the CEM assembly of August 26, 1960; author's collection.
446. Letter from Spek to Raaijmakers, January 8, 1965; author's collection.
447. Letter from Boerman and Raaijmakers to Kok, November 30, 1964; author's collection.
448. Studio Elektronische Muziek Rijksuniversiteit Utrecht, "Memorandum van de bespreking gehouden op 8 maart 1965 in de studio voor elektronische muziek van de R.U. Utrecht" [Memorandum of the meeting held on March 8, 1965, at the Utrecht University electronic music studio], March 11, 1965; author's collection.
449. Entries in Koenig's 1965 datebook; Koenig's private collection. Letter from Raaijmakers to De Vries, May 28, 1965; author's collection.
450. Letter from Raaijmakers to Koenig, April 27, 1965; letter from Koenig to Raaijmakers, May 4, 1965; author's collection, and letter from Raaijmakers to Van Baaren, May 11, 1965. Netherlands Music Institute.
451. Letter from Raaijmakers to De Vries, May 28, 1965; Netherlands Music Institute.
452. At that time, the academic year of the Royal Conservatoire started in January; today, it begins in September.
453. Letter from Raaijmakers to Miep Oddens-Roggen, June 9, 1965; author's collection. The full program of this concert was: 1. Stockhausen, *Mikrofonie II* for choir, Hammond organ and ring modulators; 2. Johannes G. Fritsch, *Fabula Rasa* for four loudspeaker groups; 3. Michael von Biel, *Fassung* for five loudspeaker groups, and 4. Stockhausen: *Mikrofonie I*.
454. CD booklet for *Karlheinz Stockhausen – Klavierstücke I–XI – Mikrofonie I & II* (Sony Classical S2K 53346), 22–3.
455. Emile Wennekes, ed., *Koninklijk Conservatorium 175 jaar: Traditie – Ontdekking – Vernieuwing* (The Hague: Koninklijk Conservatorium, 2001), 88.
456. Kasander, *150 jaar Koninklijk Conservatorium*, 135.
457. Interview with Dick Raaijmakers by Han Reiziger, October 23, 1986. Quoted in Arjen Mulder and Joke Brouwer, eds., *Dick Raaijmakers: A Monograph* (Rotterdam: V2\_Institute for the Unstable Media / NAI Publishers, 2008), 410.

# References

## Books and Periodicals

- Alink, R. J. H., C. J. Dippel and K. J. Keuning. 1947. Het metaal-diazonium-systeem voor fotografische reproductie. *Philips Technisch Tijdschrift* 10: 289–320.
- Alons, L. 1951. Nieuwe ontwikkelingen op grammofoongebied. *Philips Technisch Tijdschrift* 4: 86–96.
- Badings, Henk. 1936. *De hedendaagsche Nederlandsche muziek*. Amsterdam: Bigot en Van Rossum.
- Badings, Henk and Arie Brandon. 1956. Concrete, Electronische en Radiofonische Muziek. *Radio Electronica* 3: 144–147, 152.
- Badings, H. and J. W. de Bruyn. 1957. Elektronische muziek. *Philips Technisch Tijdschrift* 9: 269–79.
- Beck, Caspar. 1993. *Henk Badings' symfonische blaasmuziek*. Utrecht: Stichting NIB.
- Beer, Roland de. 1984. En Varèse deed "kwè-kwè." *de Volkskrant*, 27 January: 13.
- Beeren, W. A. L., Hedi Buursma, Albert Kuiper, Paul Luttk, Evelien Luursema and Talitha Schoon, eds. 1979. *Actie, werkelijkheid en fictie in de kunst van de jaren '60 in Nederland*. Rotterdam: Museum Boymans-Van Beuningen.
- Blanken, I. J. 1992. *Geschiedenis van Philips Electronics N.V.: De ontwikkeling van de N.V. Philips' Gloeilampenfabrieken tot elektrotechnisch concern*. Leiden: Martinus Nijhoff.
- . 1997. *Geschiedenis van Philips Electronics N.V.: Onder Duits beheer*. Zaltbommel: Europese Bibliotheek.
- . 2002. *Geschiedenis van Philips Electronics N.V.: Een industriële wereldfederatie*. Zaltbommel: Europese Bibliotheek.
- Blok, L. 1940. Een toongenerator. *Philips Technisch Tijdschrift* 9: 276–82.
- Boehmer, Konrad. 2006. Pierre Schaeffer's 'Traité.' In Pierre Schaeffer. *Traktaat van de muzikale objecten*, trans. Konrad Boehmer, 17–22. Ubbbergen: Uitgeverij Tandem Felix.
- Boer, K. de. 1940. Stereofonische geluidswaergave. *Philips Technisch Tijdschrift* 4: 112–19.
- . 1940. Proeven met stereofoonplaten. *Philips Technisch Tijdschrift* 6: 187–91.
- . 1940. Stereofonische geluidswaergave. PhD diss., Technische Hoogeschool Delft.
- . 1941. Stereofonische registratie op Philips-Miller-film. *Philips Technisch Tijdschrift* 3: 88–93.
- . 1946. Stereofonische afbeelding. *Philips Technisch Tijdschrift* 2: 51–6.
- Boer, K. de and A. Th. van Urk. 1939. Een eenvoudig toestel voor geluidsregistratie. *Philips Technisch Tijdschrift* 4: 111–18.
- Boer, K. de and R. Vermeulen. 1939. Een installatie voor een slechthoorende. *Philips Technisch Tijdschrift* 11: 329–32.
- Boersma, Kees. 2002. *Inventing Structures for Industrial Research: A history of the Philips Nat.Lab. 1914–1946*. Amsterdam: Aksant Academic Publishers.
- Bruynèl, Ton. 1964 *Reliëf*. Amsterdam: Donemus.
- Casimir, Hendrik B. G. 1983. *Het toeval van de werkelijkheid: Een halve eeuw natuurkunde*. Amsterdam: Meulenhoff Informatief.
- Castelot, André. 1959. Athenian enchantment. *International Lighting Review* 4: 134–44.
- Dam, Peter van. 2006. *Ir. Louis C. Kalf: Het artistieke geweten van Philips*. Eindhoven: [Z]OO producties.
- Davies, Hugh, ed. 1967. International Electronic Music Catalog. *Electronic Music Review* 2/3.
- Delauné, J. 1955. Robot Guide Installation at "La Bénédicteine," Fécamp. *International Lighting Review* 2: 52–4.
- Dibbets, K. H. F. M. 1993. Spreekende films: De komst van de geluidsfilm in Nederland 1928–1933. PhD diss., University of Amsterdam.
- Dippel, C. J. and K. J. Keuning. 1947. Problemen bij de fotografische reproductie, in het bijzonder van spreekende film. *Philips Technisch Tijdschrift* 3: 65–96.
- Eimert, Herbert. 1952. *Lehrbuch der Zwölfmontechnik*. Wiesbaden: Breitkopf & Hartel.
- Emmerson, Simon. 2007. *Living Electronic Music*. Aldershot: Ashgate Publishing Limited.
- Engel, Friedrich, Gerhard Kuper and Frank Bell. 2008. *Zeitschichten: Magnetbandtechnik als Kulturträger*. Potsdam: Polzer Media Group GmbH.
- Garity, William E. and Watson Jones. 1942. Experiences in Road-Showing Walt Disney's Fantasia. *Journal of the Society of Motion Picture Engineers*, July.
- Garity, William E. and J. N. A. Hawkins. 1941. Fantasound. *Journal of the Society of Motion Picture Engineers*, August.
- Geddes, Keith. 1972. *Broadcasting in Britain 1922–1972*. London: Her Majesty's Stationary Office.
- Gielsing, Ramón and Michel Waisvisz. 1985. Een bescheiden ontketening. *Wolfsmund* 13/14: 126–34.
- Harley, James. 2004. *Xenakis: His Life in Music*. New York and London: Routledge.
- Jelinek, Hanns. 1952. *Anleitung zur Zwölfmontkomposition*. Wien: Universal-Edition.
- Joray, Marcel, ed. 1963. *Nicolas Schöffer*. Neuchatel: Éditions du Griffon.
- Kalf, L. C. 1941. *Kunstlicht en Architectuur*. Amsterdam: Meulenhoff & Co. N.V.
- Kalf, L. C. and W. Tak, 1954. Multi-use Ceilings. *International Lighting Review* 6: 174–83.
- Kalf, L. C., W. Tak and S. L. de Bruin. 1958. 1958. Verwezenlijking van het "Elektronisch gedicht" in het Philipspaviljoen op de Wereldtentoonstelling te Brussel. *Philips Technisch Tijdschrift* 6/7: 161–208.
- Kanach, Sharon, ed. 2008. *Music and Architecture by Iannis Xenakis*. New York: Pendragon Press.

- Kasander, John. 1976. *150 jaar Koninklijk Conservatorium: Grepen uit de geschiedenis*. Den Haag: Koninklijk Conservatorium.
- Kleis, D. 1959. Moderne geluidstechniek II: Elektro-akoestische voorzieningen in grote theaters. *Philips Technisch Tijdschrift* 2-3: 54-74.
- Koenig, G. M. 1955. Studioteknik. *die Reihe 1*: 29-30.
- 1971. *Summery Observations on Compositional Theory*. Utrecht: Institute of Sonology.
- 1991. *Ästhetische Praxis: Texte zur Musik: Band 1, 1954-1961*. Saarbrücken: Pfau Verlag.
- 1992. *Ästhetische Praxis: Texte zur Musik: Band 2, 1962-1967*. Saarbrücken: Pfau Verlag.
- 2002. *Ästhetische Praxis: Texte zur Musik: Band 5, Supplement II*. Saarbrücken: Pfau Verlag.
- 2007. *Ästhetische Praxis: Texte zur Musik: Band 6, Supplement III*. Saarbrücken: Pfau Verlag.
- Kok, Willem. 1955. Harmonische Orgels. PhD diss., Technische Hogeschool Delft.
- Kullberg, Ludy. 1954. Naar een radiofonische kunstvorm. *Mens en Melodie* 11: 343.
- Lambilliotte, Maurice. 1960. *Tentoonstelling te Brussel 1958, de kunsten*. Brussel: Commissariaat-Generaal van de Regering bij de Algemene Wereldtentoonstelling 1958 te Brussel.
- Leeuw, Ton de. 1958. *Experimentele Muziek: Een lezingenreeks in het seizoen 1957-'58 voor de A.V.R.O. microfoon*. Hilversum: Algemene Vereeniging Radio Omroep.
- 1958. Experimentele muziek te Brussel. *Mens en Melodie* 11: 343-46.
- Loescher, F. A. 1960. Technical aspects at the Fifth Anniversary of Gravesano. *Gravesaner Blätter* XV/XVI: 12-7.
- Lootsma, Bart. 1984. Een ode van Philips aan de vooruitgang. *Wonen-TABK* 2: 10-7.
- 1984. Le Poème Electronique. *Wonen-TABK* 2: 20-31.
- 1984. Poème électronique: De reconstructie van een ontstaansgeschiedenis. In *De bevrijding van de klank*, ed. Elmer Schönberger, 61-6. Amsterdam: Stichting ASKO.
- Leussink, Jos. 1974. Orestes; radiofonische opera van H. Badings: Een muziekhistorische plaatsbepaling. Doctoraalscriptie, Utrecht University.
- MacDonald, Malcolm. 2003. *Varèse: Astronomer in Sound*. London: Kahn & Averill.
- Mâche, François-Bernard, ed. 2001. *Portrait(s) de Iannis Xenakis*. Bibliothèque nationale de France.
- Malmberg, Bob. 1967. Muziek beheerst leven van Gottfried Koenig. *Nieuw Utrechts Dagblad*, 26 August.
- Manning, Peter. 2004. *Electronic and Computer Music*. Oxford University Press.
- Matossian, Nouritza. 1986. *Xenakis*. New York: Kahn & Averill.
- Meulen, M. J. C. van der. 1939. Een wagen voor geluidsopname volgens het Philips-Miller systeem. *Philips Technisch Tijdschrift* 3: 78-83.
- Meyer, Felix and Heidi Zimmermann, ed. 2006. *Edgard Varèse: Composer, Sound Sculptor, Visionary*. Woodbridge, Suffolk: The Boydell Press.
- Meyer-Eppler, Werner, ed. 1955. *Gravesano: Musik, Raumgestaltung, Elektroakustik*. Mainz: Ars viva Verlag.
- Mol, H. 1960. *Geloof en bijgeloof in de fonetiek*. The Hague: Mouton & Co.
- Monnikendam, Marius. 1968. *Nederlandse componisten van heden en verleden*. Amsterdam: A. J. G. Strengholt N.V.
- Morawska-Büngeler, Marietta. 1988. *Schwingende Elektronen*. Cologne: P. J. Tonger Musikverlag.
- Motte-Haber, Helga de la. 1993. *Die Musik von Edgard Varèse*. Hofheim: Wolke Verlag.
- Mul, Jan. 1957. Verslag opening studio Delft. *de Volkskrant*. 30 September: 2.
- Mulder, Arjen and Joke Brouwer, eds. 2008. *Dick Raaymakers: A Monograph*. Rotterdam: V2\_Institute for the Unstable Media / NAi Publishers.
- Ouellette, Fernand. 1973. *Edgard Varèse: A musical biography*. London: Calder & Boyars.
- Paap, Wouter. 1954. Bilthoven, Muziekweek Gaudeamus. *Mens en Melodie* 9: 297-99.
- 1956. Elektronische muziek. *Mens en Melodie* 9: 270-71.
- 1956. Muziekweek Gaudeamus. *Mens en Melodie* 9: 290-92.
- Peters, Peter. 1995. *Eeuwige jeugd: Een halve eeuw Stichting Gaudeamus*. Amsterdam: Donemus.
- Petzoldt, H. 1958. A Time Delay Unit for Continuous Operation. *Gravesaner Blätter* XI/XII: 20-8.
- Phaidon editors. 2008. *Le Corbusier Le Grand*. London: Phaidon Press Limited.
- Petit, Jean, ed. 1958. *Le poème électronique: Le Corbusier*. Paris: Les éditions de minuit.
- Philips, Afdeling electro-acoustiek. 1948. Een demonstratiezaal voor het registreren en weergeven van geluid en voor filmprojectie. *Philips Technisch Tijdschrift* 7: 193-202.
- Raaijmakers, Dick. 2005. *Cahier "M": A Brief Morphology of Electric Sound*. Trans. Richard Barrett. Leuven: University Press, Revised edition.
- Remedi, G. 1956. Kermis der wetenschap. *Philips Technisch Tijdschrift* 2: 62-8.
- Ryan, Kevin and Brian Kehew. 2006. *Recording the Beatles*. Houston, Texas: Curvebender Publishing.
- Samama, Leo. 1986. *Zeventig jaar Nederlandse muziek 1915-1985*. Amsterdam: E. M. Querido's uitgeverij B.V.
- Schelp, Arend. 1946. Radio-rubriek. *Mens en Melodie* 7: 221.
- Schepp, Ole and Fred Kamphuis. 1983. *George Pal in Holland 1934-1939*. Den Haag: Holland Animation.
- Scherchen, Hermann. 1984. *Aus meinem Leben: Rußland in jenen Jahren*. Berlin: Henschelverlag Kunst und Gesellschaft.
- Schoenberg, Arnold. 1911. *Harmonielehre*. Leipzig-Wien: Universal Edition.
- Schoots, Hans. 1995. *Gevaarlijk leven: Een biografie van Joris Ivens*. Uitgeverij Hans Mets.
- Schouten, J. F. 1938. Lichtbuiging aan geluidsfilm. *Philips Technisch Tijdschrift* 10: 303-10.
- 1939. Synthetisch geluid. *Philips Technisch Tijdschrift* 6: 176-83.
- Schurink, J. J. 1954. De electrodynamische dubbelconuulspreker. *Philips Technisch Tijdschrift* 10: 289-98.

## References

- Siellet, L. F., M. Dérivé, L. Gaymard and G. Leblanc. 1955. Light and Sound bring to Life the Monuments of France. *International Lighting Review* 1: 17–33.
- Snel, D. A. 1952. Toestellen voor magnetische geluidsregistratie. *Philips Technisch Tijdschrift* 6: 165–74.
- Sterken, Sven. 2006. Biografie van het Philips-paviljoen 1953–1959. In *Make it New: Le poème électronique*, ed. Han le Blanc, 63–8. Eindhoven: Stichting Alice.
- Steijns, Frank. 1994. Henk Badings (1907–1987): Biografie & stijl: Analyse van zijn vioolconcerten: Bespreking van zijn pedagogische vioolwerken. PhD diss., Lemmens Institute Leuven.
- Stockhausen, Karlheinz. 1957. ...wie die Zeit vergeht.... *die Reihe* III: 13–42.
- \_\_\_\_\_. 1986. Nr. 12 – Kontakte – Elektronische Musik – Realisationspartitur. London: Universal Edition.
- Stokowski, Leopold. 1943. *Music for All of Us*. New York: Simon and Schuster.
- Tak, W. 1946. Nagalmmeting. *Philips Technisch Tijdschrift* 3: 82–8.
- \_\_\_\_\_. 1947. Het meten van de nagalmtijd volgens de methode met exponentieel aangroeiende versterking. *Philips Technisch Tijdschrift* 12: 371–9.
- \_\_\_\_\_. 1958. Het elektronisch gedicht – de geluidseffecten. *Philips Technisch Tijdschrift* 6/7: 167–69.
- Tazelaar, Kees. 2009. Poème électronique. Trans. Jane Bemont. Programme notes for the Varèse Symposium of the Holland Festival, 12 June, Amsterdam.
- \_\_\_\_\_. 2011. The Loudspeaker Speaks. Trans. Richard Barrett. In *Witteveen+Bos-Prijzen voor Kunst+Techniek 2011 – Dick Raaijmakers*, 11–30. Deventer: Witteveen+Bos.
- Treib, Marc. 1996. *Space Calculated in Seconds*. New Jersey: Princeton University Press.
- Ungeheuer, Elena, ed. 2002. *Elektroakustische Musik*. Laaber: Laaber-Verlag.
- Urk, A. Th. van. 1938. Zaalacoustiek en nagalm. *Philips Technisch Tijdschrift* 3: 65–73.
- Varèse, Edgard. 1998. The Liberation of Sound. In *Contemporary Composers on Contemporary Music*, eds. Elliott Schwarz and Barney Childs, 196–208. New York: Da Capo Press.
- Varèse, Louise. 1972. *Varèse, A Looking-Glass Diary*. New York: W.W. Norton & Company Inc.
- Varga, Bálint András. 1996. *Conversations with Iannis Xenakis*. London: Faber and Faber Limited.
- Vegesack, Alexander von, Stanislaus von Moos, Arthur Rüegg and Mateo Kries, eds. 2007. *Le Corbusier: The Art of Architecture*. Weil am Rhein: Vitra Design Stiftung gGmbH.
- Ven, Aad van der. 1984. Varèse en de dieptonen van Philips. *Haagse Courant*, 11 February.
- Vermeulen, R. 1930. Machines voor de weergave van sprekende films. Reprint from *De Ingenieur* 49.
- \_\_\_\_\_. 1936. Het Philips-Miller systeem voor geluidsregistratie. *Philips Technisch Tijdschrift* 4: 107–14.
- \_\_\_\_\_. 1938. Zaalacoustiek en verstaanbaarheid. *Philips Technisch Tijdschrift* 5: 143–51.
- \_\_\_\_\_. 1938. Zaalacoustiek en geluidsabsorptie. *Philips Technisch Tijdschrift* 12: 368–76.
- \_\_\_\_\_. 1939. Het onderzoek van luidsprekers. *Philips Technisch Tijdschrift* 12: 371–80.
- \_\_\_\_\_. 1940. Perspectieven voor een ontwikkeling van de viool. *Philips Technisch Tijdschrift* 2: 40–5.
- \_\_\_\_\_. 1948. Multiplicatie van concerten. *Philips Technisch Tijdschrift* 6: 167–75.
- \_\_\_\_\_. 1955. Stereonagalm. *Philips Technisch Tijdschrift* 7–8: 223–31.
- \_\_\_\_\_. 1958. Stereo-Reverberation. *Journal of the Audio Engineering Society* Volume 6 issue 2: 124–30.
- Vermeulen, R. and J. de Boer. 1936. Optische modellen ter bestudeering van de acoustiek van toneelzalen. *Philips Technisch Tijdschrift* 2: 46–52.
- Vermeulen, R. and W.K. Westmijze. 1949. Het expressor-systeem voor muziekoverdracht. *Philips Technisch Tijdschrift* 10: 285–94.
- Voermans, Erik, ed. 1992. *Peter Schat – Rudolf Escher: Brieven 1958–1961*. Zutphen: Walburg Pers.
- Voeten, Jessica. 1997. *Een Nederlands wonder: Vijftig jaar Holland Festival*. Amsterdam: Walburg Pers / Stichting Holland Festival.
- Vries, Jan-Willem de. 2012. *De Toonder Animatiefilms*. 's-Hertogenbosch: Silvester Strips uitgeverij b.v.
- Vries, Marc J. de. 2005. *80 Years of Research at the Philips Natuurkundig Laboratorium 1914–1994*. Amsterdam: Pallas Publications.
- Vrijman, Jan. 1962. *De werkelijkheid van Karel Appel*. Amsterdam: De Bezige Bij.
- WDR Hauptabteilung Musik. 1968. *Zwanzig Jahre Musik im Westdeutschen Rundfunk*. Cologne: Westdeutschen Rundfunk Köln.
- Weltens, Arno, Rob Marx, Arie den Dikken and Max Cramer. 2002. *Kathedralen en Luchtkastelen van de Omroep in Hilversum*. Zwolle, Waanders uitgevers.
- Wen-chung, Chou, ed. 1966. The Liberation of Sound (Excerpts from lectures by Varèse). *Perspectives of New Music* Vol. 5 no. 1: 11–9.
- Wennekes, Emile, ed. *Koninkrijk Conservatorium 175 jaar: Traditie – ontdekking – vernieuwing*. Den Haag: Koninkrijk Conservatorium.
- Wever, Peter. 2008. Le Corbusier versus de Nederlandse architecten. In *Dichtbij klopt het hart der wereld*, ed. André Koch, 113–27. Schiedam: Scriptum Art Publishers.
- Wijdeveld, Wolfgang. 1965. Een compositie voor elektronische klanksporen en orgel van Ton Bruynèl. *Mens en Melodie* 4: 111–13.
- Wijffes, Huub. 1985. *Hallo Hier Hilversum! Driekwart eeuw radio en televisie*. Weesp: Unieboek bv.
- Xenakis, I. 1958. Het architectonische ontwerp van Le Corbusier en Xenakis voor het paviljoen. *Philips Technisch Tijdschrift* 5: 126–32.
- Zuurveen, Frans. 1992. Van radiolamp naar Compact Disc – en verder. In *Eindhoven Muziekstad*, ed. Jan van Oorschot and Frans Krämer. Hapert/Eindhoven: Kempen Pers bv.

## Archives and Institutions

EYE Film Institute Netherlands, Amsterdam, Netherlands  
Fondation Le Corbusier, Paris, France  
Haags Gemeentearchief, The Hague, Netherlands  
Institute of Sonology, The Hague, Netherlands  
Koninklijke Bibliotheek, The Hague, Netherlands  
Music archive, Akademie der Künste, Berlin, Germany  
Nederlands Fotomuseum, Rotterdam, Netherlands  
Nederlands Jazz Archief, Amsterdam, Netherlands  
Netherlands Music Institute, The Hague, Netherlands  
Paul Sacher Foundation, Basel, Switzerland  
Philips Belgium N.V., Brussels, Belgium  
Philips Company Archives, Eindhoven, Netherlands  
Royal Conservatoire, The Hague, Netherlands  
Stockhausen Foundation for Music, Kürten, Germany  
Theater Instituut Nederland, Amsterdam, Netherlands  
Utrecht Archives, Utrecht, Netherlands

The author was able to examine archival materials related to Louis Kalff and the Philips Pavilion before they were transferred from the Philips Company Archives in the Netherlands to the Getty Research Institute in Los Angeles, California. In the footnotes, these materials are referred to as LKM (Louis Kalff Materials).

## Interviews, Conversations and Correspondence

Alex Balster (former recording engineer at Philips' Phonographic Industries); Paul Berg (composer, staff member at the Institute of Sonology, computer music specialist); Jan and Marjanne Boerman; Theo Boesveld (technician at the 1958 Philips Pavilion); the late Anton Buczynski (recording engineer for production of *Le poème électronique*); Michel Cools (technician at the 1958 Philips Pavilion); Frits Cordess (former managing director of the Haagsche Piano Academie); Wiel Cox (technician at the 1958 Philips Pavilion); Marianne, Peter and Ton de Bruyn (children of Jan de Bruyn); Huub de Mul (former employee at Philips Research Laboratories and Philips Company Archives); Ronald Dissevelt (son of Tom Dissevelt); the late Rien Dissevelt-Reys (widow of Tom Dissevelt); Heribert Henrich (music archive, Akademie der Künste); Huub Houët (son of Hub. Houët, organ player for *Le poème électronique*); Gottfried Michael Koenig; Wim Langenhoff (former scientist at Philips Research Laboratories); Geoffrey Madge (pianist and composer, student of Badings); Malcolm McDonald (music critic, author of *Varèse: Astronomer in Sound*); Felix Meyer (director of the Paul Sacher Foundation); Max Naveaux (film operator at the 1958 Philips Pavilion); Kees Nijssen (former engineer in Philips' ELA division); Paul Op de Coul (musicologist and student of Henk Badings); the late Dick Raaijmakers; the late Rita Reys (jazz singer, sister-in-law of Tom Dissevelt); Jan Romijn (former engineer in Philips' ELA division); Jo Scherpenisse (former employee at Philips Research Laboratories and former technician at STEM / Institute of Sonology); Michel Soete (technician at the 1958 Philips Pavilion); Boudewijn Tak (son of Willem Tak); Gilius van Bergeijk (composer, student of Kees van Baaren and Dick Raaijmakers); Paul Vancoppenolle (film operator at the 1958 Philips Pavilion); Frits Weiland (composer, former staff member at STEM / Institute of Sonology); Chou Wen-chung (composer, assistant of Edgard Varèse); Peter Wever (collector and historian).

# Appendix

## Foreign Quotations in Original Languages

### Part I

**Note 56: Belangrijk radio-experiment: Vandaag stereofonische uitzending," *Trouw* newspaper (June 15, 1946): 2.**

"Links, ter hoogte van uw theekastje zal de vleugel klinken, terwijl op den divan een paukenist schijnt te staan. Van achter het behang klaagt zacht een aantal violen; onder den hardstoel schettert een trompet."

**Note 69: Roelof Vermeulen, "Muziekcentrum," report for Philips Research Laboratories, June 20, 1945.**

"Kunst, Wetenschap en cultuur in het algemeen blijven onmiskenbare elementen voor een snel herstel van de veerkracht van ons volk. [...] Er kondigt zich onmiskenbaar de geboorte van nieuwe sociale en economische verhoudingen aan die wellicht het beste te karakteriseren zijn als de emancipatie van de arbeidersklasse; zoals ook indertijd de Franse revolutie de emancipatie inhield van de burgerij. Dit behoeft niet een dictatuur van het proletariaat te betekenen; doch wel een relatief groter aandeel voor de arbeiders in de vruchten der gemeenschappelijke werkzaamheid. Voor een evenwichtige en rustige ontwikkeling zal echter essentieel zijn dat niet uitsluitend materiële vruchten aan de nieuwe laag der bevolking ten deel vallen, doch dat zij ook toegang verkrijgt tot de geestelijke en culturele waarden, die onze maatschappij dragen. Het is wel niet toevallig, dat deze ontwikkeling zich voltrekt in een tijdsgewicht, waarin door de vooruitgang der productiemethoden en de ontplooiing van wetenschap en techniek, de industrie ook werkelijk in staat zal zijn om een zo talrijke groep op ruimere schaal te voorzien."

**Note 70:** "Als fabrikant van muziekinstrumenten zal het voor de firma Philips, vooral van belang zijn na te gaan hoe deze kunstvorm zich zal aanpassen aan de nieuwe maatschappelijke verhoudingen. Dat wij hier radiotoestellen, grammofoons en geluidsfilmprojectoren tot de muziekinstrumenten rekenen, ligt in het wezen van onze visie op de toekomst der muziek, die voornamelijk uit 'canned music' zal bestaan. [...] Nu is de mogelijkheid geschapen, dat de muziek zich gaat ontwikkelen van een met zorgen omringd kasplantje tot een gezonde en levende kunst, die, evenals de literatuur, slechts incidenteel financiële hulp behoeft. Bij de massaproductie, die dit mogelijk moet maken, gaat onvermijdelijk nog meer verloren van het directe contact tussen kunstenaar en publiek, dan thans in de grote concertzalen reeds het geval is. Maar ook in de literatuur is het een reeds lang overwonnen standpunt, dat men alleen een vers of vertelling zou kunnen genieten door de persoonlijke voordracht van een declamator. [...] Het is begrijpelijk dat musici onwillekeurig een gevoel van afkeer bekruipt, wanneer hun voorspeld wordt dat de elektrische weergave de normaal gangbare vorm zal worden waarin hun werk onder het publiek zal worden verspreid. [...] er doet zich

reeds het verschijnsel voor dat muzikiefliefhebbers soms de voorkeur geven aan een grammofoonplaat van bijvoorbeeld een Toscanini boven een [live uitvoering van een] provinciaal orkest. Anderzijds is het toch ook zowel economisch als artistiek een monstroom, dat een honderdtal artiesten avond aan avond dezelfde kunstwerken op het podium moeten kopiëren, en onbegrijpelijk dat tegen een dergelijk geestdodend procédé minder oppositie rijst dan tegen het werken van de fabrieksarbeider aan de, juist in kunstkringen, zoveel gesmade [lopende] band."

**Note 72:** "Voor de muziek zou [...] 'research' werk van het allergrootste belang zijn om deze te stuwen in een richting, waar het massaproduct meer zal geven dan goedkoop genot voor velen [...] Het machtigste middel om de belangstelling te verruimen is ongetwijfeld een ingrijpende verbetering, zonder uitbreiding van het aantal lesuren, van het muziekonderwijs op de lagere school, waar de thans meestal onbenullige zanglesjes vervangen dienen te worden door een methodisch 'algemeen vormend onderwijs.' [...] Anderzijds zal vooral aandacht worden besteed aan de speciale eisen die door de microfoon worden gesteld. Zo zal het voor een zangeres niet meer een eerste vereiste zijn, dat haar stem een grote concertzaal kan 'vullen,' maar wel dat zij haar muzikale expressie kan uiten zonder de apparatuur door al te forse uithalen te overbelasten. Ook de dirigent en de componist zullen moeten leren welke beperkingen de reproductietechniek hun oplegt, en moeten zoeken naar de nieuwe effecten die daarbij mogelijk worden. In Amerika is door Stokowski tezamen met Bell Laboratories reeds in deze richting gewerkt."

**Note 73, 189, 282:** "Wij hopen en verwachten als vrucht van het werk in het muzieklaboratorium, dat met deze nieuwe mogelijkheden in de hand de componist weer de weg naar het hart van het volk zal weten te vinden, wat hem trouwens gemakkelijker zal vallen, indien door een betere opvoeding meer begrip voor zijn werk ontstaat. Dan zal ook de gewoonte uit de klassieke tijd in ere hersteld worden, om bij voorkeur nieuwe composities ten gehore te brengen. Daarmede zal de compositie zelf weer belangrijker worden dan de virtuositeit van de vertolker of de verschillen in interpretatie van overbekende werken, die thans ons concertleven beheersen. Dat een dergelijk muzieklaboratorium ook voor de firma Philips van belang zal zijn behoeft wel geen betoog. [...]"

Zal inderdaad het muziekcentrum ten volle aan zijn taak beantwoorden om de muziek in een nieuwe levende vorm tot het volk te brengen, dan zullen tenslotte vooral de componisten door het geven van opdrachten hierin betrokken moeten worden. De moderne werken vinden een zeer beperkt gehoor, namelijk bij hen, die verzaagd zijn met klassieke muziek, zoals bijvoorbeeld de muzikrecensenten. Om het contact met weer te herstellen zouden de componisten minder in de eerste plaats moeten streven



naar originaliteit, en werk dat de eeuwigheid trotseert; maar, als de goede journalist en literator, hun werk meer moeten richten op de opvoeding van het publieke begrip en goede smaak, ook al zouden vele composities niet langer leven dan een tijdschriftartikel. Voor de 'canned music' der toekomst zouden de auteursrechten geen onoverkomelijk bezwaar meer vormen. [...]

Of de overheid de het geschikte orgaan is om het kunstleven te stimuleren en te drijven valt te betwijfelen; wij hebben meer vertrouwen in de scheppende kracht van de leidende lichamen van deze tijd de grote concerns, in het bijzonder de film- en de radioindustrie. Evenals thans de namen van een Esterhazy en een Lobkowitz nog bekend zijn door hun relaties met Haydn en Beethoven, zo zou het niet uitgesloten zijn, dat in later tijden de naam Philips meer bekendheid zal ontleenen aan de invloed op de moderne muziek dan aan de industrie, die deze mogelijk maakte."

**Note 261: Printed program notes for the premiere of Ton de Leeuw's *Antiphonie*, Holland Festival, June 18, 1960.**

"De spelers bevinden zich allen op het podium, maar zijn wijd uit elkaar opgesteld, zodat de homogeniteit van het klassieke blaaskwintet doorbroken wordt. Er is dus een streven naar een ruimtelijke spreiding [...], dat niet los staat, maar een gevolg is van de toegepaste seriële schrijfwijze. Deze streeft immers naar een splitsing van de klank en naar een verzelfstandiging van de muzikale elementen. [...] Niets is gevaarlijker dan een goed ingerichte elektronische studio (zoals in casu de Philipsstudio te Eindhoven). Het 'alles is mogelijk' leidt al gauw tot effectbejag en tot verarming van het creatieve bewustzijn. Méér dan ooit is het in deze geluidswereld noodzakelijk voor de componist om de beheersing op te brengen [...].

Ook in dit opzicht is de seriële schrijfwijze bij uitstek actueel: zij voert tot uiterste concentratie en tot een zo groot mogelijke beperking in het uitgangsmateriaal."

**Note 265: Dick Raaijmakers, "Reisrapport," report for Philips Research Laboratories, November 11, 1958.**

"Als uiteindelijk ideaal staat Stockhausen voor ogen; en met orkestelementen omringen van de toehoorders in een koepelvormige zaal. Doch bij deze uitvoering bevond zich slechts 1/5 deel van de zaal tussen de haaks opgestelde orkesten, waarbij de rest van de toehoorders en toekijkers slechts een enorm breed orkest zag zonder bijzonder nieuwe eigenschappen. [...]

Doch hier gaat het blijkbaar, en dit wordt voorop gesteld, om een nieuwe organisatie van luisteren; niet naar klank doch naar richting. [...]

Het tweede werk dat algemene belangstelling onderzocht was *Poésie pour pouvoir* van P. Boulez, voor drie orkesten en vijf luidsprekergroepen. Hierbij werd een akoestische gedachte als uitgangspunt gekozen; een spiraalvormige beweging van geluid. Men trachtte dit te realiseren door midden boven in de zaal een luidsprekerzuil te hangen die een hoek maakte met de vloer van ca. 45 graden en bovendien kon ronddraaien met behoud van deze hoek, om zo een gehele zaal te kunnen bestrijken. Daaronder waren midden in de zaal de drie orkesten op drie verschillende hoogten opgesteld. [...] Aan de vier wanden hingen vier luidsprekergroepen. Elke groep bestond uit een speciale lage tonen-straler met een uitwendige afmeting van 2,5 x 2,5 meter, en tien luidsprekerzuilen van Telefunken

voor de midden- en hogere frequentiegebieden. Het publiek tenslotte zat in twaalf groepen om de orkestleden.

Het ten gehore gebrachte elektronische geluidsdeel klonk erg teleurstellend en slecht van kwaliteit waarbij vage en verdoezelde, overwegend lage geluiden in galmen-de flarden niet het minst aan welke geluidsspiraal dan ook deden denken. Dezelfde klanken kwamen ook uit de roterende zuil, waarbij de richting van dit geluid bepaald werd door die van de enorm hoge modulatie-ruis waarmee dit alles gepaard ging. [...]

Rest nog de aandacht te vestigen op de wanverhouding tussen inspanning en resultaat; het orkest was 110 man groot met drie dirigenten; verder de enorme geluidsinstallatie met 45 luidsprekers waaronder de vier speciale lage toon-stralers en de roterende zuil; een acht-sporen magnetofoon met complete service installatie; vijf technici en tenslotte vier maanden voorbereiding in de elektronische studio te Baden-Baden van de Südwestfunk, welke instelling eveneens de weergave in deze zaal heeft verzorgd. Het werk duurde acht minuten."

## Part II

**Note 40: Subtitles excerpted from a recorded interview with Le Corbusier in Jean Barsac's 1987 documentary *Le Corbusier 1887-1965*, broadcast in three parts on September 14, 21 and 28, 1996, on TROS television in the Netherlands.**

"Ik kan straks boven de sacristie met muziek experimenteren. De muziek wordt een spektakel. Met 12.000 mensen en versterkers. Ik zei tegen de pastoor: In plaats van zo'n oud mens op een accordeon [vraag] Harmonium... [antwoord] In plaats van zo'n afschuwelijk ontstemd harmonium kunt u er prachtige nieuwe kerkmuziek voor laten componeren, openlucht muziek. Ik ben bij Varèse in New York geweest. Ik zei: componeer 'n spetterend stuk voor me voor vol [groot] orkest. Als je er zin in hebt, maar geen sombere muziek. Het moet muziek zijn met veel kabaal."

**Note 61: Letter from Le Corbusier to Louis Kalf, September 14, 1956.**

"J'ai obtenu l'accord de M. Varèse pour la création de la partition musicale. Je le connais bien; il est très apprécié et, moi-même, j'apprécie en lui le sérieux et la substance de sa musique. Je ne voudrais en aucun cas que cette partition musicale ait une allure "tapageuse" extrémiste. Je suis persuadé qu'entre M. Varèse et moi il y a une unité non seulement de génération mais d'expérience dans deux domaines différents. [...]

Pour réaliser ou faire réaliser des thèmes dessinés ou colorés, graphiques ou photographiques ou picturaux, je n'ai pas besoin de collaborateurs; c'est mon métier. Concernant le reste, j'ai en M. Varèse un homme de ma génération de haute probité, qui est enthousiasmé par une collaboration avec vous dans cette affaire. Ici, à l'atelier, j'ai un dessinateur qui est ingénieur d'une part, musicien d'avant-garde d'autre part. Il est tout à fait versé dans les dernières manifestations de la musique concrète ou autre. Il deviendra une des mains de M. Varèse si l'on peut dire. M. Varèse fera sa musique d'après mon scénario et en étroit contact avec moi. (Je vous signale que je suis d'une famille de musiciens et que dès mon enfance j'ai été baigné dans cette atmosphère.)"

**Note 62: Letter from Louis Kalff to Le Corbusier, October 13, 1956.**

“En ce qui concerne l’accompagnement musical et sonore nous avons noté votre désir de vous assurer la collaboration de M. Varèse.

Il est toutefois entendu que M. Varèse devra tenir compte de notre souci de faire apprécier la qualité de nos reproductions par le public et incorporer en conséquence, dans sa partition des passages symphoniques.”

**Note 64: Internal message from H. J. R. G. Hartong to Louis Kalff, November 15, 1956.**

“Ik begrijp echter niets van de muziek, die onder leiding van Evert Cornelis zou moeten zijn.

[...] M.i. moeten wij trachten hiervoor een dirigent van formaat te krijgen – als hij het tenminste spelen wil! – dus b.v. Eduard van Beinum of, in overleg met Evert Cornelis, een andere dirigent en orkest.”

**Note 66: Letter from E. B. W. Schuitema to Louis Kalff, November 19, 1956.**

“Ingesloten doe ik je enkele gegevens toekomen over de componist Varèse, waaruit blijkt, dat de muziek die hij componeert uitsluitend en alleen voor elektronische instrumenten geschikt is.

De Heer Cornelis is van mening, dat wanneer je aan deze man zou opdragen werken met een symfonisch-muzikale inslag te componeren, dit alleen maar onbevredigende resultaten kan opleveren afgezien van het feit, dat het nog de vraag is, of hij de opdracht aanvaardt.

Wij hebben platen, die van zijn muziek bestaan besteld en zodra ze in ons bezit zijn zullen wij je berichten, welk oordeel wij ons gevormd hebben over de kwaliteit van het gecomponeerde.”

**Note 74: Report by Louis Kalff on a meeting with Le Corbusier and Edgard Varèse, December 19, 1956.**

“Op 19 december hebben wij ‘s middags een lang gesprek gehad met de architect Le Corbusier, de componist Varèse uit New York, waarbij tevens aanwezig waren de Heren Evert Cornelis uit Baarn en Xenakis van het bureau van de architect. [...] Wij krijgen de indruk dat zowel het te ontwerpen geluid door Varèse als het paviljoen en het scenario van Le Corbusier inderdaad het beoogde effect zullen bereiken, namelijk dat Philips een avant-gardistische demonstratie geeft die zeker een van de merkwaardigste van de gehele tentoonstelling zal worden.”

**Note 80: Willem Tak, “Een scenario voor het Philips paviljoen Wereldtentoonstelling 1958,” February 7, 1957.**

“*Scenario*: De zaal is in een dieprode gloed gehuld, terwijl een onderaards gerommel klinkt. Dit gerommel gaat langzaam over in een bastoon, die uiteindelijk zich concentreert aan het onderste deel van wand A. Op deze wand verschijnt boven het geluid eerst vaag, dan toenemend in helderheid, een filmbeeld, waarin men plant en bloem versneld ziet groeien. Het beeld bereikt een hoogte van minstens 8 m. Terwijl het rode licht vervaagt, gaat de bastoon over in andere geluiden, die steeds hoger in toon worden. Deze geluiden bewegen zich langs de wand naar boven met het groeien van de plant. Zij resulteren in een zeer hoog, twinklend geluid, dat langzaam overgaat in een gezongen akkoord terwijl het filmbeeld vervaagt. De zangstemmen krijgen een melodie waarbij nagalm wordt toegevoegd. Met behulp van uvioel en variabele diafragma’s worden verschillende delen van het plafond, waarop merk-

waardige figuren in fluorescentieverf zijn aangebracht intermitterend aangestraald. De diafragma’s variëren met verschillende snelheid en hebben verschillende afmetingen. De figuren groeien dus steeds vanuit een centrum en nemen af naar dit centrum. Na een climax verzwakt het nagalmgeluid vrij snel en verdwijnt naar de horizon in de richting van wand B. In deze richting vindt ook het uitdoven van de uvioellichten plaats. Aan wand B verschijnt met veel schaduweffecten een belicht reliëf. Uit dit reliëf aan wand B klinkt een fagottoon, gevolgd door een echo met nagalm van de horizon in de richting van wand B. Na enkele herhalingen gaat de echo over in een zoevend geluid, dat snel nadert en via het plafond aan de tegenoverliggende wand C verdwijnt. Met gelijke snelheid loopt uit het reliëf een lichtfiguur, langs het plafond, eindigend in een filmbeeld aan wand C, waarbij in kleuren de beweging van een cellen wordt getoond. Tijdens de projectie klinken geluiden van verschillende klankkleur en toonhoogte, afwisselend als flitsen uit alle mogelijke verschillende richtingen, gesynchroniseerd met gekleurde lichtflitsen. De geluidsflitsen gaan na enige tijd over in een horizontaal rondlopend geluid langs de wanden op enige hoogte boven de vloer. De lichtflitsen die oorspronkelijk samenvielen met de geluidsrichtingen gaan langzaam over in het aanflitsen van hoe langer hoe meer lichtbronnen, totdat de wanden en het plafond bijzonder helder zijn verlicht met een vrij duidelijke scheiding op de hoogte van het rondlopend geluid. De geluidscirkel stijgt nu sprongsgewijze, terwijl de verlichting onder de geluidslinje dooft, totdat een centrumarmatuur de zaal in schemerlicht zet en het geluid betrekkelijk zwak het hoogste punt, zowel in kleur als plaats bereikt. De helderheid van het centrumarmatuur neemt vervolgens flikkerend toe, terwijl het geluid met vibrato en toenemende nagalm een climax bereikt. Een en ander eindigt abrupt. De normale zaalverlichting wordt begeleid door een herkenningmelodie.”

**Note 81: “Luidsprekeropstelling:** Voor het verkrijgen van de verschillende geluidseffecten zal gebruik moeten worden gemaakt van een bijzonder groot aantal luidsprekers. Vele van deze luidsprekers zullen direct naar het publiek zijn gericht. [...]

Voor de nagalm zullen speciale luidsprekers worden gemonteerd, die niet naar het publiek, doch naar het plafond zijn gericht.[...] De nagalmapparatuur met bijbehorende luidsprekers moet als een compleet gescheiden installatie worden gezien, waarvan uitsluitend het niveau aan de andere apparatuur wordt gekoppeld.

De bodemluidsprekers zullen onder de vloer moeten worden aangebracht.[...] Voor het onderaards geroffel dienen de grondluidsprekers als een groep. [...] Ruw geschat zijn dit circa 50 luidsprekers van 20 W, gevoed door een kilowatt versterker. [...]

Voor de panoramische effecten van het geluid kan men op twee wijzen te werk gaan.

De luidsprekers langs de af te leggen weg worden in groepen verdeeld. Iedere groep wordt door een versterker gevoed. De ingangspotentiometers van deze versterkers worden op een as gekoppeld. uit en in faden volgen elkaar op. Het stereofonisch effect is zeer goed waarneembaar, mits de toehoorders zich niet te dicht bij de luidsprekers bevinden.

Voor het verkrijgen van bewegend geluid is het gebruikmaken van een contactenwals over de uitgang van een

versterker eveneens mogelijk. De luidsprekers over de af te leggen weg zijn ieder aan een contact verbonden. Het sleepcontact moet minstens vier luidsprekers in werking stellen, voor het verkrijgen van het goede vermogen. Het stereofonisch effect is op deze wijze voor iedereen exact waarneembaar. Voor sommige effecten dient deze tweede methode daarom aanbeveling. [...]

Het groeperen van de verschillende luidsprekers afhankelijk van de effecten uit het scenario geschiedt met relais die gestuurd worden door een aantal stuursporen, die synchroon lopen met de geluidsband. [...]

Het is een strenge eis de zaal akoestisch zodanig te behandelen, dat de nagalmtijd vrijwel te verwaarlozen is. Alleen in dat geval zullen de geluidseffecten volkomen tot hun recht komen. De wanden van de zaal en het plafond zullen daartoe met een absorptie-materiaal voor lage en hoge tonen moeten worden bekleed. [...]

Uit het bovenstaande zal het duidelijk zijn, dat het van het allergeeueste belang is, teneinde tot een welslagen van het experiment te komen reeds bij het ontwerp van het gebouw een duidelijk inzicht te hebben van de effecten, waarop het scenario is gebaseerd."

**Note 87: Letter from Louis Kalf to Le Corbusier, April 2, 1957.**

"Nous sommes en train d'installer dans un hangar à Eindhoven une espace où nous pourrions essayer les 2 mois à venir les effets de son et de lumière, qui ont été préconisés pour notre pavillon.

Entretemps nous allons terminer une maquette, échelle 1: 12,5, du pavillon afin de permettre à M. Tak d'indiquer l'endroits des haut-parleurs. On peut dans cette maquette examiner non seulement l'extérieur mais aussi l'intérieur. Cette maquette sera tout prête la fin de cette semaine. Nous croyons qu'il serait très utile que vous veniez un jour avec M. Xenakis voir la maquette et répondre à un nombre de questions qui se sont présentées pendant la fabrication. Vous verrez alors également l'extérieur avec toutes les petites coupoles nécessaires pour les haut-parleurs. Il y en aura plus que 300. [...]

Nous aimerons avoir aussi à notre disposition un des disques de M. Varèse afin de l'utiliser pour nos expérimentations. [...]

Nous pourrions utiliser votre présence à Eindhoven pour prendre un bout de film, qui fera partie d'un reportage concernant la construction de notre pavillon."

**Note 93: Letter from Edgar Varèse to Louis Kalf, June 5, 1957.**

"Je tiendrais, ne fut ce que mentalement, à commencer les esquisses pour la composition sonore pour le pavillon de 1958 et, ainsi que vous me l'avez écrit en Mars dernier, être tenu au courant des résultats de vos expériences et possibilités du son. Il est aussi indispensable que j'obtienne au plus tôt le scénario, afin de savoir exactement quelles sont ses exigences."

**Note 99: Letter from Louis Kalf to Edgar Varèse, July 24, 1957.**

"Ce sont des effets de son dans l'espace, donc de mouvement, de direction, de réverbération et d'échos, qui jusqu'ici n'ont jamais été utilisés dans des installations électroniques que pour accentuer le réalisme dans la mu-

sique des salles de concert et des salles de théâtre comme le Scala à Milan. S'il vous sera possible d'utiliser ces effets nous croyons que le démonstration sera encore plus intéressante et nouvelle qu'avec une reproduction automatique traditionnelle."

**Note 126: Letter from Louis Kalf to E. Bomli, November 2, 1957.**

"Bijgaand zend ik U zoals afgesproken de partituur van Varèse. Voor de realisatie hiervan zou het dus nodig zijn een koor (circa 16 personen) en een aantal percussie players te verzoeken te willen meewerken. Gaarne zal ik zo spoedig mogelijk van U vernemen of en wanneer dit mogelijk is. Wij zullen het op prijs stellen indien U tevens voor de benodigde repetitie-ruimte kunt zorgen."

**Note 193: Letter from Willem Tak to Iannis Xenakis, March 24, 1958.**

"Les effets du son stéréophonique, réverbérations, disparitions etc. aussi que transfert à vitesse variable, filtres d'octave, passage dans le générateur d'impulsion etc. sont possibles. [...] Je me sens, cher Xenakis, bien heureux de vous pouvez informer ainsi et j'espère avoir le plaisir de vous retrouver bientôt pour travailler ensemble."

## Part III

**Note 19: Letter from Walter Maas to Roelof Vermeulen, December 15, 1954.**

"[...] wij en met ons vele muziek-creatieve talenten in ons land dat op een of andere manier toch nog de mogelijkheid wordt gevonden de nieuwe materie der elektronica voor hun toegankelijk te maken. Zoals wij U reeds hebben gezegd is het verwijt van Heine, dat hij op de dag van het laatste oordeel het liefst in Nederland zou willen zijn, omdat men daar altijd 30 jaar achter is, voor ons de stimulans alles in het werk te stellen om deze achterstand in te halen [...]. Juist Philips is op dit terrein op de gehele wereld in de eerste gelederen en is daardoor bij uitstek in de gelegenheid om ons in bovengenoemd streven terzijde te staan.

Onze volgende internationale muziekweek vindt plaats van 29 augustus tot 3 september 1955 en aangezien dit jaar een jubileumjaar voor ons is, zou het voor ons een buitengewone voldoening zijn als er op de een of andere wijze nog een weg ter realisatie van onze plannen zou kunnen worden gevonden."

**Note 44: Definition of electronic music from the minutes of the CEM assembly of April 16, 1957.**

"Elektronische muziek ontstaat bij de weergave van kunstzinnig gemonteerde fragmentarische opnamen, die met magnetische band- of met andere geluidsregistratie-apparaten zijn verkregen; deze opnamen kunnen zijn gemaakt, zowel van natuurlijke geluiden als van synthetische trillingen, die met elektrotechnische of mechanisch-elektronische apparaten zijn verkregen, dan wel kunnen zij bestaan uit combinaties van beiderlei herkomst en al dan niet vooraf zijn gemodificeerd."

**Note 77: Ton de Leeuw, "Experimentele muziek te Brussel," *Mens en Melodie* 11 (1958): 344-45.**

"Terwijl de Amerikanen vooral abstracte neigingen toonden, kregen wij hier alle mogelijke beelden van gorilla's, machines, mensenmassa's te zien, waarbij ook in de mu-

ziek rijkelijk gebruik werd gemaakt van illustratieve effecten. Van de componist van Déserts, Edgard Varèse, had ik echter meer verwacht, veel meer zelfs, gezien ook de unieke kansen welke Philips geboden heeft om dit werk te realiseren.”

**Note 89: Jan Mul, “Verslag opening studio Delft,” *De Volkskrant* (September 30, 1957): 2.**

“Door de uitvinding van de geluidsband is de mogelijkheid geschapen via een luidspreker de meest bandeloze geluiden voort te brengen. Men noemt dit ‘elektronische muziek.’ [...] De voordelen van elektronische muziek zijn enorm: orkesten raken overbodig, dirigenten eveneens; conservatoria kunnen hun deuren sluiten. [...] Intussen moet men het gevaar dat dit troetelkind voor onze jonge componisten meebrengt niet overschatten. Een componist van het ware soort zal spoedig ontdekken dat er tóch meer muziek zit in een slecht bespeelde mandoline en ervaren dat het helemaal niet nodig is een toon via elektronische apparaten te misvormen. Welk een bizarre geluiden met gewone muziekinstrumenten verkregen kunnen worden viel te horen op een grammofoonplaat met een werk uit 1926 van de 71-jarige [sic] componist Edgard Varèse, die de inwijding van de studio met zijn aanwezigheid luister bijzette. Dr. Maasj, [sic] de vader van de zogenaamde Gaudemus-componisten, jubelde na de afloop dat met deze elektronische studio Nederland weer een toekomst had. Gelukkig maar!”

**Note 105: Letter from Marleen van Hall and Tymen van der Kooy to the members of the Dutch House of Representatives’ education, arts and sciences committee of November 20, 1958.**

“Immers, deze nieuwe geluid en ruimtekunst, die een even grote revolutie betekent ten opzichte van de traditionele muziek als de film dat bijvoorbeeld was ten opzichte van het toneel, betekent een radicale herwaardering esthetische en muzikale waarden, materieel zowel als spiritueel.

[...] Deze ‘andere muziek’ vraagt om projectie in de ruimte, in het rond; zij wil de luisteraar van vele kanten benaderen. Dit alles vereist een omschakeling van het denken, niet alleen in de technisch-wetenschappelijke zin, maar ook in psychologische en esthetische zin. De verhouding tot andere kunstuitingen als toneel, poëzie, dans, film, radio en televisie zijn daarmee voortdurend aan de orde.

Men constateert een merkwaardige overeenkomst in geestelijk klimaat en werkwijze met de moderne dichters, schilders en andere kunstenaars. Men bemerkt, dat door onderling contact en gemeenschappelijke werken, nieuwe, onvoorziene oplossingen op velerlei gebied gevonden kunnen worden en dat die zeer bevruchtend werken in wijde kring.

Men kan zich op den duur niet onttrekken aan de indruk dat hier misschien sprake is van een ‘Zeitgeist,’ die op zeer veel verspreide plaatsen in de wereld kunstenaars van velerlei pluimage als het ware naar elkander drijft om samen vorm te geven aan wat al sterk in de geest leeft.

[...] Alle kunst heeft immers ontmoetingscentra, brandpunten nodig, waar zij bevruchtend kan werken en bevrucht wordt.

[...]

Aangezien de elektronische muziek het vooral moet hebben van een samenspel tussen wetenschap en kunst, van natuurkundige ingenieurs en componisten, is het te verwachten, dat een bloei van deze nieuwe kunstvorm alleen kan ontstaan door hun samenwerking. Daarom kan men alleen maar hopen, dat ook in Nederland op den duur

een artistiek en wetenschappelijk klimaat zal ontstaan, waarbinnen een levende avant-garde muziek en de andere kunsten kunnen groeien.”

**Note 108:** “dat het avant-garde Theater Test een mogelijkheid van bestaan zou krijgen, om met geregelde voorstellingen te beginnen in plaats van de incidentele opvoeringen en geluidsprojecties, zoals die tot nu toe plaatsvonden. Er zou door het feit van bestaan van een werkelijk avant-garde theater een ‘research-laboratorium van de kunst’ kunnen groeien.”

**Note 128: Willem Kok, “Algemene beschouwing over elektronische muziek en de daarmee samenhangende praktische vraagstukken.”**

[...] deze proef zou overal elders in Nederland of zeer kostbaar zijn geweest, of door bijkomstige, maar belangrijke neveninvloeden tot een verkeerd resultaat hebben geleid. De ontwikkeling van deze nieuwe kunst dient in volle vrijheid tot stand te komen en zo mogelijk buiten invloed te blijven van een commerciële stimulans. Hoewel de Ned. Radio Unie zowel als Philips ruime outillage bezitten om componisten het beoefenen van elektronische muziek mogelijk te maken (aanzienlijk beter zelfs dan thans in Delft) is het toch van essentieel belang te achten, dat de ontwikkeling (en bloei) tot stand komt in een vrije omgeving waar bovendien gemakkelijk contacten met werkers op andere terreinen (o.a. van de kunst) tot stand kunnen komen.”

**Note 130:** “Akoestiek van muziek en muziekinstrumenten wordt in ons land niet als afzonderlijke wetenschap beoefend. De behoefte hieraan is, afgezien van de ontwikkeling der elektronische muziek, stellig aanwezig voor geluidsregisseurs bij omroep-, televisie-, film- en grammofoonplatenbedrijf, ook voor musicologen.”

**Note 132: Henk Badings, “Enige opmerkingen over importantie, urgentie en doelstelling van een elektronische studio.”**

“In muzikaal opzicht levert dit vooral mogelijkheden op het gebied van de stemming, de timbrevorming, de intensiteitsverhouding en de continue toonspectra. Maar ook in de derde muzikale dimensie – de tijd – heeft de elektronische muziek nieuwe mogelijkheden geopend. Terwijl de traditionele muziek zich om praktische redenen beperken moet tot een klein aantal tijds waarden en tijdsverhoudingen, kan de elektronische muziek iedere tijds waarde, die binnen de menselijke waarnemingsdrempel ligt, benutten en bijvoorbeeld desnoods noten, notengroepen en tempi in irrationele verhoudingen toepassen.”

**Note 133:** “Het verleggen van uitvoering en interpretatie van het eigenlijke ‘concert’ naar een daaraan voorafgaande samenstelling uit de klankelementen is overigens iets, wat in de normale radiopraktijk geenszins ongebruikelijk is en het is nu wel bewezen, dat dit noch de kwaliteit van de uitvoering noch de expressiviteit behoeft te schaden. En in een tijd, waarin de radio, televisie, film en grammofoon een grote rol spelen in het dagelijks leven van de mens is er weinig aanleiding om de onmisbaarheid voor de elektronische muziek als een ernstig nadeel te beschouwen. Bovendien houdt dit nadeel ook voordelen in. Door het geluid te splitsen over twee of meer kanalen en deze geluids delen weer te geven over groepen van luidsprekers die zich op verschillende plaatsen in de zaal bevinden, kan men de ruimte in de weergave betrekken, het geluid beweeglijk maken en t.a.v. gerichtheid of diffusiteit beïnvloe-

den, hegeven de traditionele muziek behoudens uitzonderingen (als de trompet achter de schermen in Beethovens *Leonore III*) niet kent. De binding aan een luidspreker maakt de elektronische muziek tot het meest geschikte klankmateriaal voor radio, film, televisie en grammofoon. Dan is het luidsprekergekluid namelijk de doelstelling. In alle andere gevallen (b.v. de symfonie van Beethoven weergegeven door een luidspreker) is het luidsprekergekluid een surrogaat, dat zich bij grotere perfectie eer sterker dan zwakker laat voelen.”

**Note 186: Roelof Vermeulen, “Aantekening voor een bespreking op 11 oktober 1961 in Eindhoven met prof. dr. H. B. C. Casimir en mr. J. H. des Tombe.”**

“[...] het werk dat Badings heeft opgebouwd, de kennis en vaardigheid die hij aan Raaijmakers heeft geleerd, en waaraan deze weinig of niets heeft toegevoegd, de reputatie en goodwill die hij in binnen maar ook in buitenland in zo ruime mate heeft verworven, zomaar, zonder meer in te pikken en aan een ander ter beschikbaar te stellen.”

**Note 187:** “Er is naar mijn mening slechts één man in Nederland die de kennis en de capaciteiten, de durf en de energie heeft om op het gebied van de elektronische muziek iets zelfstandigs te doen, en genoeg geestkracht bezit om niet met de grote mode domweg mee te lopen. Alle anderen, Ton de Leeuw, Escher, Hans Kox, Dissevelt en Raaijmakers hebben op hem geparasiteerd, al hebben zij dan andere stijlen gebruikt, en dan achteraf op hem gescholden.”

**Note 188:** “[...] in handen dreigt te raken van een betrekkelijk kleine groep z.g. jonge componisten, is er slechts één goede, en fatsoenlijke oplossing, d.i. Badings de leiding te geven van datgene wat hij van de grond af aan heeft opgebouwd, en wat uitsluitend door zijn doen reeds een uitstekende naam in de wereld heeft verworven.”

**Note 192: Draft of a letter from Rudolf Escher to Hendrik Casimir, November 8, 1961.**

“Verspilling van geestelijke energie, verlamming van de drang tot experimenteren, tot expansie en creativiteit is van zulk een strijd het onafwendbare gevolg en deze verspilling wordt nu al bijna een half jaar lang niet alleen getolereerd maar bepaald gevoed [...] door tamelijk veel ondeskundigheid inzake [...] elektronische muziek als compositorische discipline, als theorie en praktijk.”

**Note 195:** “Dom daarentegen is het om de artistieke integriteit van deze jonge pioniers bij voorbaat verdacht te maken door het verspreiden van anekdotes over hun vermeende ‘anti-technische’ of ‘anti-wetenschappelijke’ gezindheid en de leugen te verspreiden als zouden deze lieden ‘maar wat aan-rotzooien.’ [...] Zij zijn, integendeel, serieuze werkers met een sterke drang tot exploreren van onbekend terrein. Zij hebben daarom wat beters te doen dan in gebed te verzinken voor een magnetofon of een Allison-filter.”

**Note 221: Gottfried Michael Koenig, *Ästhetische Praxis: Texte zur Musik: Band 1*, 258–60, original text.**

“Musik ist im Grunde ein unteilbares Ereignis; wenn wir einen Ton hören, so enthält er zwar außer seiner Tonhöhe auch eine Farbe und eine Dynamik, auch dauert er eine bestimmte Zeit. Das machen wir uns aber nicht im einzelnen klar, sondern stehen sensuell und psychologisch unter

dem Gesamteindruck dieses Akustisches Ereignisses. [...] Erst zum Zweck der Analyse zerlegen wir den musikalischen Vorgang in die einzelnen Parameter und diese wieder in die einzelnen Stufen. In diesem Sinn könnten wir sagen, daß der musikalische Klang auch aus einer bestimmten *Richtung* komme, die in die Gesamtwahrnehmung eingeht.”

**Note 222:** “Wenn wir einen Schall wahrnehmen und ihn so deutlich wie möglich hören wollen, drehen wir unseren Kopf so, daß die Ohren die optimale Position einnehmen. Mit anderen Worten: wir registrieren nicht die Richtung des Klanges, sondern wir ändern *unsere* Position dem Schall gegenüber, damit er aus einer bestimmten Richtung, nämlich der besten, kommt. [...] Das Argument, mehrere im Raum Verteilte Schallquellen würden die Konstruktion der Musik deutlicher machen, kann demnach nicht stimmen; im Gegenteil, sie müßte undeutlicher werden in dem Maß, in dem der Schall aus ungünstigen Richtungen kommt. [...] Komposition als Kunst besteht ja gerade darin, Sachverhalte zu formulieren und sie sodann mit den Mitteln der Musik so deutlich wie möglich darzustellen. Musik ist gewissermaßen die Deutlichkeit selber, oder sie ist keine. [...] Die musikalische Undeutlichkeit ist Dilettantismus.”

**Note 223:** “Man könnte nämlich verlangen, daß der Klang nicht nur aus verschiedenen *Richtungen* kommt, sondern auch in verschiedenen Richtungen sich *bewegt*. Diese Parameter hat mit der Deutlichkeit nichts zu tun, er ist eine neue Sensation. [...] Je mehr heute die Möglichkeit der Raumkomposition ins Bewußtsein der Komponisten eindringt, je größer vielleicht auch die Bereitschaft der Veranstalter, Instrumentalensembles im Konzertsaal zu verteilen, desto mehr sollten die Komponisten ihren Widerstand gegen den Raum schärfen, um nicht widerstandslos der Spielerei oder einer Fetischisierung der Mittel zu verfallen. Über den Raum in der Musik wissen wir noch fast gar nichts; man kann ihn nach und nach erforschen, aber nicht frisch und fröhlich Stücke für ihn komponieren. Die bisherigen Erfahrungen nämlich geben allen Grund zur Skepsis.”

**Note 270: W. A. L. Beeren et al., eds., *Actie, werkelijkheid en fictie in de kunst van de jaren '60 in Nederland*, 35.**

“[...] een ruimte waarbij de gefixeerde punten als het podium, stoelen, balkons en orkestbak dienen te worden vervangen door mobiele installaties. De akoestiek moet variabel kunnen zijn. De zaal moet kunnen worden ingericht op de eisen van het kunstwerk in plaats van het tegenovergestelde. De MES beoogt de ontwikkeling van een ‘auto-theater’, een theatervorm waarin ook het publiek zelf aan de handelingen deelneemt. Het zal het traditionele eenrichtingsverkeer doorbreken en vervangen door een interactie, zodat het publiek wordt losgemaakt uit zijn onverschilligheid. Ook de stilte is een belangrijk element in deze nieuwe theatervorm. Tijdens de stilte wordt het publiek onrustig, totdat het gaat ervaren dat het zelf met zijn gedrag deel van het werk is.”

**Note 301: “Résonance van Ton Bruynèl resonanceert niet,” *Utrechts Nieuwsblad* (November 15, 1962): 4.** “Na de pauze improviseerde hij op elektronische muziek van de Utrechtse componist Ton Bruynèl die klinkt als een darmstoring met versterker. In de nummers *Vier A.M.* en *Impro* waren zijn bewegingen in hoofdzaak primaire reacties op het geluid. Zo dansende zou men de spanning in

een schuilkelder tijdens een luchtaanval draaglijkere kunnen maken. [...] Het willekeurige getik en gescheur op de metaalplastiek werd spoedig irriterend. Doek en beelden droegen niets wezenlijks tot het zelf al onwezenlijke schouwspel bij. [...] *Résonance* resoneerde niet."

**Note 321: Letter from Dick Raaijmakers to Miep Odens-Roggen of March 15, 1964.**

"[...] wanneer compositorisch bewerkte geluiden vanaf een band door luidsprekers klinken, het absoluut onmogelijk is allerlei valse en niet terzake doende associaties met 'echte' geluiden (geluiden die klinken omdat er iets gebeurt) uit te sluiten. [...] Een ander foutief gebruik vindt plaats wanneer de geluiden tonig worden en als het ware als muziek uitgevoerd schijnen te worden; door wie... wanneer...? Dit kan zeer verborgen in de beste stukken verscholen zitten. Bij de meeste elektronische stukken is dan ook van alles reeds 'ingebouwd': zelfs quasi ruimtelijkheid alsof microfoons reportages hebben verzorgd van iets dat nooit gebeurde."

**Note 325:** "Een geluid legt niet één weg af, doch miljoenen wegen. Denk aan een klok in een hoge toren en dan aan al de huizen en velden daar omheen. Ja zelfs tussen geluidsbron en oor zijn duizend wegen denkbaar. [...] Een luidspreker echter kan geluiden laten horen die dan weer zeer 'direct' klinken (alsof er iets zeer dichtbij klinkt; tussen bron en oor slechts één weg bijvoorbeeld!) en dan weer ver alsof het geluid verwaaid is en amper definieerbaar. [...] Er zijn talloze manieren (ook dus in de 'natuur') waarop geluid met zichzelf sommeert: Daarom is een geluid feitelijk steeds anders en bezit steeds een gewijzigde vorm. Deze wijziging kan zover doorgevoerd worden dat nieuwe klanken ontstaan met andere vorm en andere kleur. Het someren of optellen noemen wij: autosynchronisatie."

**Note 327: Letter from Dick Raaijmakers to Jaap Spek of January 6, 1964.**

"Onderwerp van morfititeit is de verandering die geluid ondergaat in ruimte. De leer van die veranderingen heet akoestiek, en heeft niets met muziek van doen. Doch de verandering moet eerst tot een muzikaal peil geheven worden, en aan essentiële muzikale grootheden worden gebonden, voordat morfititeit componeerbaar kan worden genoemd."

**Note 343: Letter from Dick Raaijmakers to Miep Odens-Roggen of April 20, 1964.**

"Zeker weet ik nu, nooit geluiden te kunnen vormen zoals Jan dat kan. Jan's aanleg hiervoor is heel bijzonder en hij doet het, alles vergetend zoals een kind verdiept kan zijn. Het bijzondere is dat hij niet komt tot geluiden met een tendentieuze karakter als Bruynèl maakt, doch ik zou willen zeggen authentieke vormen die helemaal echt zijn – helemaal Jan, zoals een Bruckner symfonie helemaal Bruckner is."

**Note 363: Letter from Gottfried Michael Koenig to Herbert Eimert of November 12, 1951.**

"Weil seine 'Sinfonie des einsamen Menschen' ein solches Maß von Perfektion und Eindringlichkeit besitzt, wird die surrealistische Geräuschmontage eine Klippe sein, an der neuerungsfreudige Komponisten nicht leicht vorbeisteuern werden. Ich halte die Versuche Schaeffers für sehr interessant und wesentlich; ich interessiere mich schon deshalb für sie, da ich dem literarischen Surrealismus sehr nahe

stehe. Aber sie sind vermutlich einmalig; es gibt Dinge, die man nicht wiederholen kann, ohne sie zu imitieren. Man muß sich vor allem darüber klar sein, daß Musik in dem Augenblick anfängt, wo man das chaotische Geräusch zum 'Ton' abstrahiert. Seitdem gibt es eine Musikgeschichte. Eine Geräuschgeschichte gibt es nicht und wird es nicht geben."

**Note 372: Letter from Gottfried Michael Koenig to Jean Cocteau, February 3, 1952.**

"[...] behandelt das Zwölftonkollektiv gewissermaßen als Malgrund, die Struktur der ganzen Musik ist eine farbige. Wie bei den alten Meistern legt sich eine Schicht über die andere, jeder kompositorische Vorgang wird nach seinen Farbqualitäten bemessen und entsprechend eingesetzt. Das endgültige "Bild" ergebt sich dann aus der Instrumentierung (für Orchester), besser noch aus der Umwandlung in elektronischen Klang."

**Note 401: Letter from Gottfried Michael Koenig to Erfriede Koenig, July 3, 1955.**

"Die Arbeit mit Stockhausen macht sehr viel Freude [...] Er ist sehr anregend, begeisterungsfähig und von Ideen besessen. Ein sehr guter Kamerad dazu [...], mit dem ein Hand-in-Hand-Arbeiten möglich ist. Wir reden kaum miteinander, nur Arbeitsanweisungen oder Fragen werden ausgetauscht. Dafür unterbrechen wir schon einmal die Arbeit für eine halbe Stunde, manchmal sogar für eine Stunde, weil wir ins Diskutieren geraten. Auf diese Weise schaffen wir wirklich etwas."

**Note 416: Letter from Heinz-Klaus Metzger to Gottfried Michael Koenig, July 14, 1958.**

"Malraux, De Gaulles rechte Hand, macht mir letztlich Freude. Er will auf Staatskosten ein elektronisches Studio unter Varèses Direktion in Paris aufrichten – ich habe Sie Varèse als Mitarbeiter empfohlen. Setzen Sie sich mit ihm, wo Sie an der Perspektive nicht etwa sich desinteressieren wollen, darüber in Verbindung."

**Note 422: Letter from Gottfried Michael Koenig to Hendrik Casimir, June 30, 1963.**

"Obwohl ich von Hause aus Musiker bin, haben mich von Anfang an die technischen Probleme interessiert, vor allem die Möglichkeit, den Klang in eine Beziehung zum Formverlauf zu setzen und beides, den Klang selber und die genannte Beziehung, präzise zu beschreiben. [...]

Mich bewegt seit Jahren die Frage, wie man

1. den Bereich neuartiger Klänge vergrößern,
2. dem Komponisten eine noch größere Kontrolle über sein Material erlauben und
3. die technische Arbeit mit den Geräten des Studios vereinfachen könnte.

[...]

Zum theoretischen Aspekt [...] gehören aber auch die einzelne Amplitude und der zeitliche Abstand zur nächsten. Die herkömmliche Tonbandtechnik macht diesen Bereich aber nicht zugänglich. Im Gegenteil: je mehr Transformationen durch Filterung, Verhallung oder Modulation das Grundmaterial unterworfen wird, desto unkontrollierbarer wird das Resultat, desto größer wird der Arbeitsaufwand, desto mehr leidet die technische Qualität aufgrund der vielfachen Kopie. Die elektronische Musik terminiert zu einer Instrumentalmusik mit anderen Instrumenten."



# Index

- Abbey Road Studios, 59  
Aboville, R. d', 103, 105, 113, 114  
*Achter de schermen*, 93–95, 276n279, 285n94  
Adamov, Arthur, 193, 197: *Ping-Pong*, 197  
Adorno, Theodor W., 247  
Advance Instruments impulse generator, 263  
AEG magnetic tape recorder, 174  
Alberteum Palais de la Science, 186  
Aldeburgh Festival, 105  
Alford, Kenneth, 79, 102, 275n232  
Alford: "Colonel Bogey March," 79, 102  
Algemene Vereniging Radio Omroep (AVRO), 66, 72, 88, 179, 182, 199, 209, 210, 285n75  
ALGOL, 260  
Alons, L., 53, 273n130  
ambiophonic; ambiophony, 14, 49, 53, 54, 59–61, 70, 71, 77, 86, 97, 99, 122, 220, 238  
American Wind Symphony Orchestra, 226  
Amplex model 401A tape recorder, 115  
Amroh Handy Sound tape recorder, 233  
Andriessen, Hendrik, 198  
Andriessen, Jurriaan, 87  
Andriessen, Louis, 192, 231, 262, 292n338  
APELAC, 186  
Appel, Karel, 218, 219: *Musique barbare*, 218, 219  
Arbeitsgemeinschaft für freie Komposition, 247  
arena theatre, 195, 197  
Arnaud, Pierre, 144, 153, 280n158, 280n159  
Arthuys, Philippe, 179  
artificial head microphone; dummy head, 14, 28–32, 44, 45, 47, 48, 52, 71, 270n47, 272n92  
ASP, 261  
Audio-Visual Research Foundation, 186, 187  
Baaren, Kees van, 13, 207, 222, 232, 262–265, 291n290: *Variationi per orchestra*, 262  
Badings, Henk, 10–14, 34, 35, 63–70, 72, 74, 76–78, 81, 83, 85–89, 91–93, 95, 99, 101, 119, 130, 131, 141, 144, 152, 174–188, 192, 193, 201, 202, 205, 209, 210, 212, 214–218, 220, 223–226, 232, 233, 235, 246, 247, 252, 255, 257, 266, 269, 274n193, 276n253, 276n277, 278n67, 281n170, 281n176, 284n22, 284n24, 285n81, 286n102, 294n428, 296n438: *Capriccio*, 85, 87, 91, 210, 233; *De Nacht van Morgen*, 72, 286n102; *De Vliegende Hollander*, 72; *Dialogues for Man and Machine*, 89, 183, 186; *Drei Schwärmerien*, 290n246; *Elektromagnetische Klankfiguren*, 87, 276n253; *Evolutionen*, 85, 281n176; *Geluid der Werkelijkheid*, 83, 85, 144; *Genese*, 89, 91, 186; *Kain en Abel*, 14, 34, 35, 63, 66–69, 71, 72, 76, 77, 95, 130, 131, 177, 178, 180, 182, 183, 185, 220, 281n170, 281n176, 284n22, 285n81, 287n133; *Martin Korda D.P.*, 185, 276n277; *Mens en Machine in Eindhoven*, 85, 184, 185; *Orestes*, 65–67, 88, 175, 176, 226, 235, 274n188; *Pittsburgh Concerto*, 226, 290n259; *Second Symphony*, 65; *Second Violin Concerto*, 65; *The Countess Cathleen*, 65, 174, 286n102; *Third Symphony*, 65; *Three Lucebert Songs*, 225, 290n246; *Toccata I and II*, 226; *Variations électroniques*, 72, 75–77, 83, 131, 184, 185, 192, 268, 281n176, 284n24  
Baltan, Kid (Dick Raaijmakers), 77–80, 89, 94, 101, 102, 175, 177, 183, 184, 209, 210, 227, 275n228, 275n240, 286n104  
Barber, Samuel, 141  
Barnstijn, Loet Cohen, 23  
Bartók, Béla, 47, 115, 198  
Bayerischer Rundfunk, 249  
BBC, 27, 28, 53, 66, 271n55, 274n188  
Beatles, the, 59, 268, 276n280, 292n342  
Beinum, Eduard van, 47, 65, 118  
Béjart, Maurice, 84, 186  
Belgian National Institute for Radio Broadcasting (NIR), 184–186  
Bell System Laboratories, 39  
Berg, Paul, 261  
Bergeijk, Gilius van, 262, 264  
Berio, Luciano, 89, 186, 188, 285n74: *Thema (Omaggio a Joyce)*, 89, 186  
Berliner Philharmoniker, 119  
Bernstein, Leonard, 141  
Berretty, Yoka, 193  
Berten, Walter Michael, 250, 251  
Beyer, Robert, 174, 247, 273n161, 283n7  
Boehmer, Konrad, 192, 252  
Boer, Kornelis de, 30–33, 36, 270n44, 270n47  
Boer, Hans de, 159–161, 282n205  
Boerman, Jan, 12, 13, 91, 180, 197, 198, 200, 209, 212, 213, 218, 231, 232, 234–237, 243–246, 262–264, 268, 269, 286n117, 291n309, 292n344, 292n345: *Alchemie 1961*, 91, 198, 209, 212, 213, 231, 232, 234, 245, 268, 293; *Alliage*, 198; *De Zee*, 213, 245, 246; *Kompositie 1972*, 213; *Kompositie 1979*, 213; *Musique concrète*, 198; *Ruine*, 198  
Bois, Rob du, 231  
Bomli, E., 140, 178, 184, 209, 213, 214, 218, 222, 230, 255  
Bon, Maarten, 262, 295n444  
Bottema, Piet, 176  
Bottje, Will Gay, 224  
Boudreau, Robert Austin, 226  
Boulez, Pierre, 89, 90, 116, 184, 226, 231, 285n74, 293n357, 293n376: *Deux études concrètes*, 293n 357, 293n376; *Le marteau sans maître*, 285n74; *Piano Sonata no.2*, 285n74; *Poésie pour pouvoir*, 89, 90  
Brandon, Arie, 66, 67, 70, 131, 176  
Brasilia, 277n7  
Britten, Benjamin, 103, 105, 106, 114, 118, 119, 284n47: *The Young Person's Guide to the Orchestra* (aka *Variations and Fugue on a Theme of Purcell*), 105, 106  
Broeksz, J., 182  
Brons, Carel, 222

- Brown, Earle, 186, 257, 285n74  
 Bruel & Kjaer 1610 / 1612 third-octave filter, 199, 200, 235, 237, 286n125  
 Bruin, Simon Leo de, 120, 124–126, 155, 166–168, 279n104  
 Bruins, Theo, 262  
 Brumsteede, Emile, 76  
 Brün, Herbert, 252  
 Bruyn, Jan de, 63, 67, 69–71, 75–78, 120, 130–132, 141–145, 149, 151, 152, 192, 279n104, 294n428  
 Bruynèl, Ton, 12, 91, 218, 231–236, 243, 244, 260, 291n295, 291n305, 292n338: *Afscheid*, 233; *Collage Resonance II*, 234, 291n305; *Nocturne grave*, 233; *Reflexes*, 233; *Reliëf*, 243, 244, 292n338; *Resonance I*, 91, 233, 234, 292; *Studie*, 233  
 Buczynski, Anton, 135, 144–149, 151, 152, 159, 161, 166  
 Cage, John, 141, 186, 285n74  
 canned music, 38–40, 48, 66, 77, 78  
 Cardew, Cornelius, 252  
 Carillon Films, 76  
 Carter, Elliott, 141  
 Casimir, Hendrik, 18, 62, 96, 98, 142, 143, 151, 209, 213–216, 232, 236, 256, 257, 261, 262, CBC Radio, 91  
 cellophane copies (of Philimil film), 31–33, 46  
 Centro Sperimentale Electroacustico, 59, 86  
 Chaîne Nationale, 116  
 Chevalier, Maurice, 153, 281n180  
 Chottin, Georges, 154  
 Cinesonor N.V., 24  
 Cinetone film studios, 72  
 Claude, George, 18  
 Claude tubes, 18  
 Claus, Hugo, 193  
 Cléber, Jos, 80  
 Club d'Essai, 187, 248, 254, 278n46  
 Cocteau, Jean, 248, 249, 251  
 Cologne school, 72, 178, 179, 209  
 Cologne studio, 13, 174, 224, 250, 253, 260  
 Columbia Records, 170  
 Columbia University, 79, 80  
 Columbia-Princeton Electronic Music Center, 232  
 compact cassette, 96  
 Concertgebouw Amsterdam, 43, 45–47, 49, 51, 88, 270n42, 286n110  
 Concertgebouw Orchestra, 26, 45, 47, 119, 270n42, 284n47  
 Contactorgaan Elektronische Muziek (CEM), 11–13, 88, 97, 98, 177–190, 192, 193, 195, 198–201, 203–207, 209, 213, 219, 222, 230, 232, 255, 262, 274n197  
 Copland, Aaron, 141  
 Copley, Alfred L., 116  
 Cordess, Dorothea, 235  
 Cordess, Frits, 235, 291n309  
 Cornelis, Evert, 118–120, 278n63  
 Cox, Wiel, 124, 126, 165  
 CSP 1, 261  
 CYSF 1, 83–85, 144  
 d'Abouville, R. See Abouville, R. d'  
 Dantzig, Rudi van, 245, 246  
 Danzi Quintet, 87, 88, 285n69  
 DBX, 44  
 de Boer, Kornelis. See Boer, Kornelis de  
 de Boer, Hans. See Boer, Hans de  
*De bouw van het Philipspaviljoen*, 125  
 de Bruin, Simon Leo. See Bruin, Simon Leo de  
 de Bruyn, Jan. See Bruyn, Jan de  
 de Hartmann, Thomas. See Hartmann, Thomas de  
 de la Motte-Haber, Helga. See Motte-Haber, Helga de la  
 De Lantaren, 231, 234  
 de Leeuw, Reinbert. See Leeuw, Reinbert de  
 de Leeuw, Ton. See Leeuw, Ton de  
 De Luis, 233  
 de Ridder, Willem. See Ridder, Willem de  
*De televisiebeeldbuis*, 236  
 de Vries, Frank. See Vries, Frank de  
 De zwarte bonenluis, 218  
 Décade de la musique nouvelle Américaine, 141, 280n135  
 delay wheel (of the Philips electronic reverberation system), 56–59  
 des Tombe, J. H. See Tombe, J. H. des  
 Deutekom, Cristina, 140, 146  
 Deutsch, Max, 254  
 Di Bello, Victor, 91  
 Diamand, Peter, 181, 184  
 Diffusion Magnétique Sonore (DMS), 144, 153, 155, 280n159, 281n185  
 Digital Equipment Corporation (DEC) PDP-15 computer, 261  
 digital-to-analog converter, 253, 256, 260  
 Dijk, Piet van, 80  
*Diode III*; *Diode IV*, 236  
 Disney, Walt, 42, 106, 141  
 Dissevelt, Tom, 11, 34, 67, 80–83, 89, 94, 101, 175, 209–211, 215, 226–229, 275n240, 275n242, 285n96, 287n163: *Electronic Movements*, 80, 83, 227; *Fantasy in Orbit*, 226–229, 290n264; *Intersection*, 94, 209, 210, 227; "Syncopation," 82; "Vibration," 34, 81–83, 210, 227; "Whirling," 82  
 dodecaphonic; dodecaphony, 83, 88, 178, 227, 229, 262, 285n74  
 Dolby A, 44  
 Dollywood Studios, 73  
 Dome of Discovery, 103, 106  
 Donaueschinger Musiktage, 89, 278n51  
 Donemus, 179, 222  
 Dongen, Theo van, 80, 82, 87  
 Doorn, Frans van, 264  
 Dreamland, 73  
 Dresden, Sam, 53  
 du Bois, Rob. See Bois, Rob du  
 Düring, Jan, 36, 37  
 Dutch National Ballet, 245, 246, 286n117  
 Dutton, Gilbert F., 59  
 Duyster, Hoyte, 126, 142, 143  
 Edgar, Hindle, 94  
 Éditions de la Boîte à Musique, 119  
*Een groot dood dier*, 197, 236  
 Eimert, Herbert, 13, 81, 174, 179, 186, 210, 224, 240, 247, 248, 250, 251, 253, 254, 275n206, 283n7, 289n218, 294n390: *Fünf Stücke*, 179, 275n206, 289n218  
 Eindhovense Muziekschool, 37  
 Eisma, Wil: *BTH. 3457*, 289n239  
 Elder Conservatorium of Music, 226

- electric monochord, 236, 237, 263  
 electrical shaft, 23, 163, 271, 282n210  
 Electrologica factory, 294n428  
 Electrologica X1 and X8 computers, 257, 260  
 electronic reverberation, 14, 49, 55–58, 61, 69, 70, 77, 97, 98, 130, 131, 135, 149, 151, 158, 174, 175, 183, 242  
 Elektronisch Rekencentrum, 257  
*elektronische Musik*, 7, 9, 11, 12, 174, 180, 186, 209, 247  
 EMI, 59, 60  
 Endt, Pieter Maarten, 203  
 English Opera Group, 105, 284n47  
 Enkel, Fritz, 174, 250  
 envelope; envelope generator, 55, 58, 69, 132, 208, 224  
 Escher, Rudolf, 97, 98, 197–199, 204–207, 209, 212, 218, 224–226, 230, 232, 240, 257, 287n142, 288n198, 294n426: *Summer Rites at Noon*, 209, 212, 213, 218  
 Etablissements Delauné, 113  
 Evangelisti, Franco, 224, 252  
 experimental television broadcasts, 74  
 Expressor, 44–48  
  
*Fantasia*, 42, 43, 51, 106, 271n83, 272n125, 282n207  
 Fantasound, 42, 43, 53, 271n89  
 Fasset, Jim, 182: *Symphony of the Birds*, 182  
 Feenstra, Rudie, 235, 291n309  
 Ferrari, Luc, 186  
 Festival de l'Art d'Avant-Garde, 84  
 Festival Musica Viva, 116  
 Festival of Britain, 103, 104  
 Fibonacci sequences, 245, 292n344  
 Filmliga, 24  
 Films Sonores Tobis, 25  
 Fluxus, 15, 231  
 FORTRAN, 260  
 France Inter, 116  
*Fuel for the Future*, 94, 95, 285n94  
  
 Garity, William E., 42  
 Gaskell, Sonia, 182  
 Gaudeamus composers, 176, 190, 207  
 Gaudeamus foundation, 11, 67, 173, 177–179, 189, 206, 224, 230  
 Gaudeamus lecture (Koenig), 220, 221  
 Gaudeamus Muziekweek, 173, 176, 178, 195, 219, 222, 257  
 Gebouw voor Kunsten en Wetenschappen, 58, 71, 130  
 Geesink, Joop, 72–74  
 Geesink-Toonder Studio, 73  
 Gelder, Han van, 15, 74, 193, 276  
 Genootschap van Nederlandse Componisten (GeNeCo), 179, 262  
 German academy Villa Massimo, 255, 294n418  
 Gibson, Brian, 59  
 Giltay, Berend: *Polychromie I*, 289n239  
 Ginneken, Jaap van, 47, 272n111  
 Glas, 193, 285n96  
 Goeyvaerts, Karel, 247, 283n7: *Compositie nr. 5 met zuivere tonen*, 283n7; *Sonata for Two Pianos*, 247  
 golden section, 213, 245  
 Gorter, Klaus: *K45; VG56*, 289n239  
 Gould, Glenn, 91, 276n273: *Dialogues on the Prospects of Recording*, 91  
  
*Gravesaner Blätter*, 59, 86, 99, 101, 116, 136  
 Gredinger, Paul, 250, 294n390  
 Gredinger: *Formanten*, 294n390  
 Groot, Rens, 218  
 Groupe de Recherche de Musique Concrète, 116  
  
 Haagsche Piano Academie, 235  
 Haanstra, Bert, 193  
 Haas, Max de, 182  
 Habraken-van Hall, Marleen, 195, 232, 286n100  
 Hacken, Huub ten, 243  
 Hafner, Erhard, 250  
 Hall, Marleen van, see Habraken-van Hall, Marleen  
 Hambræus, Bengt, 252  
 Hammond organ, 180, 218, 295n453  
 Harley, James, 281n178, 281n185, 281n194  
 Hartmann, Thomas de, 88  
 Hartong, H. J. R. G., 43, 46, 47, 118, 142, 182  
 Hawkins, John N. A., 42  
 hearing aids, 28  
 Heine, Heinrich, 176  
 Hei, Hermann: *Elektronische Komposition I*, 275n206, 289n218  
 Hemel, Oscar van, 222  
 Hendriksen, Jens: *Philips Light/Luz/Lumire*, 285n95  
 Hendrix, Jimi, 292n342  
 Henry, Pierre, 83, 84, 116, 117, 120, 182, 186, 188, 247, 293n357: *Antiphonie*, 293n357; *Dimanche noir*, 182; *Orphe 53*, 188, 247, 293n357  
 Herv, Lucien, 159, 162  
 Hessischer Rundfunk, 249  
 Hindemith, Paul, 47, 65  
 Holland Festival, 67, 71, 88, 144, 181, 182, 184, 185, 197, 236, 246, 280n156, 284n47, 284n48, 285n79  
 Holst, Gilles, 17, 18, 26, 42–46, 62, 272n92  
 Honor TE-22 sine/square wave generator, 263  
 Horne, Dick, 94, 276n280  
 Hout, Hub., 147  
 Hoving, Hattum, 218  
 Hoving, Sieto, 193  
 Huydts, P. A. I., 178, 179, 181  
  
 IBM, 110, 253, 257, 260  
 IBM 7090 computer, 257, 260  
 Iersel, Kees van, 193, 197, 234, 236  
 Ilcken, Wessel, 80  
 Institut fr musisch-technische Gestaltung, 249, 251  
 Institut fr Phonetik und Kommunikationsforschung, 247  
 Institute for Phonetic, Acoustic and Experimental Musicological Research, 204, 215  
 Institute of Sonology, 260, 261, 286n125, 287n150, 287n158, 294n397, 295n436  
 Interlock, 164, 165, 282n211  
 International Building and Public Works Exhibition, 83, 144  
 International Congress on Acoustics, 57  
 International Days of Experimental Music, 89, 185–188, 285n74  
*International Lighting Review*, 107, 111  
 International Summer Course for New Music Darmstadt, 173, 174, 223, 247, 249  
 Internationale Kunstwoche der Musikalischen Jugend Deutschlands, 174

- Ionesco, Eugène, 193, 195, 286n103: *Jack, or the Submission*, 195, 286n103; *The Bald Prima Donna*, 195, 286n103
- Iltmann, Trudi, 225
- Ivens, Joris, 15, 24, 25, 74
- Jansen, Johan, 111
- Jelinek, Hanns, 81, 210
- Jolivet, André, 116
- Jurres, André, 222
- Kaegi, Werner, 261
- Kagel, Mauricio, 186, 252, 285n74
- Kalff, Louis, 18, 25, 36, 102–107, 111, 113, 114, 117–120, 123–127, 130, 137, 140, 142, 143, 153–156, 166–168, 269, 269n7, 277n10
- Karajan, Herbert von, 58, 105
- Kast, Pierre: *l'Architecte du Bonheur*, 283n236
- Katholieke Radio Omroep (KRO), 65
- Kerr cell technique, 25, 270n32
- Ketting, Otto, 178
- Kid Baltan (Dick Raaijmakers). See Baltan, Kid
- Klangfarbenmelodie, 69, 274n193
- Klebe, Giselher, 252, 275n206, 289n218: *Interferenzen*, 275n206, 289n218
- Kleis, D., 58
- Koch, Friedrich, 262
- Koenig, Gottfried Michael, 12–14, 71, 179, 186, 187, 219–225, 227, 229, 232, 237, 246–257, 259–261, 263, 264, 274n195, 289n219, 292n339, 293n376, 293n380, 294n397, 294n398, 294n426, 294n427, 295n431, 295n436: *Drei Orchesterstücke*, 249; *Essay*, 186, 220, 252, 289n219; *Funktionen*, 252, 294n397; *Horae*, 247, 249; *Klangfiguren I*, 250, 251, 255; *Klangfiguren II*, 71, 179, 187, 220, 252; *Projekt 1: Version 1*, 259, 260; *Reading Gaol*, 249, 251; *String Quartet 1959*, 229; *Terminus*, 229, 252, 253, 294n397
- Kok, Willem, 177–181, 189–192, 198–202, 204, 206, 222, 223, 225, 231, 235, 262, 291n299
- Kolthoff, Mark, 24
- Koninklijke Nederlandse Toonkunstenars Vereniging, 179, 222
- Koninklijke Schouwburg, 71
- Kooy, Tymen van der, 194, 195, 197, 286n104: *Klankstudie*, 195, 286n104
- Kopierkopf, 251
- Kosten, Cornelis Willem, 177, 191
- Kouwenaar, Gerrit, 234, 292
- Kox, Hans, 87, 176, 215, 218, 225
- Krenek, Ernst, 252, 275n206, 285n69, 289n218: *Spiritus Intelligentiae Sanctus*, 275n206, 289n218; *Pentagram*, 285n69
- Kretsch, 24, 25, 270n32
- Krones, Friedrich, 55
- Krückeberg, Fritz, 253
- Kuilenburg, Wim van, 209, 217, 264
- Kunst, Jaap, 88
- Kunstliefde, 233
- Kurhaus Pavilion Scheveningen, 197
- La Gaîté, 195
- Laboratorium voor Technische Physica (Delft), 191
- laboratory for experimental musicological research, 225, 232
- Lachman, Hans, 186, 187, 285n75: *Amsterdam*, 186, 285n75
- Language of Intensities, 140
- Le Corbusier, 7, 11, 84, 85, 101, 103, 106, 109, 111, 114, 115, 117–121, 124–127, 129, 130, 137, 138, 142–144, 153, 155, 156, 159, 162, 166–171, 278n40, 283n236
- Le poème électronique*, 23, 35, 99, 101, 102, 111, 114, 115, 117, 125, 127, 129, 131, 133, 137, 138–140, 142, 144–147, 149–151, 153, 155–157, 162–164, 166–171, 184, 187, 208, 271n88, 274n197, 280n127, 281n173, 281n177, 282n211, 283n238
- Leblond, Georges, 24, 270n32
- Leeuw, Reinbert de, 192, 262
- Leeuw, Ton de, 12, 87, 88, 92, 174, 176, 178, 180–183, 185–188, 195, 205, 207, 210, 215, 220, 223, 262, 285n69, 285n73, 292n338: *Antiphonie*, 87, 88, 92, 185, 210, 220, 285n69, 292n338; *Elektronische studie*, 88, 186–188, 285n73; *Job*, 87, 176, 177, 182, 183, 188; *String Quartet No.1*, 88
- Lichtveld, Lou, 15, 25, 74, 270n31
- Ligeti, György, 186, 188, 252: *Artikulation*, 186
- Lilien, Ignace, 195
- Loetafoon, 22–24
- London Symphony Orchestra, 106
- Lootsma, Bart, 282n211
- loudspeaker violins (Philolist), 36, 37, 62, 288n198
- Luders, Coen, 195
- Ludolf, Luuk, 66
- Lumley, Bob, 94
- Maas, Walter, 11, 67, 173–179, 181–183, 185, 188, 190, 200, 203, 219, 222, 230, 257, 283n14
- Maatschappij tot Bevordering der Toonkunst, 178, 203
- Maderna, Bruno, 117, 182, 186, 188, 205, 285n74, 293n376: *Dimensioni*, 285n74; *Notturmo*, 182
- Madge, Geoffrey, 226
- Malraux, André, 116, 254, 294n415
- Marsman, Hendrik, 233
- Martenot, Maurice, 42, 50, 61, 76, 83, 271n82
- Martin, Frank, 255
- Masquerage*, 182
- Masséus, Jan, 193, 195, 275n221
- Matthäus Passion*; *St. Matthew Passion*, 61, 86, 270n42
- Meinsma, G. L., 204
- Melochord, 174, 175
- Mengelberg, Willem, 27, 65, 270n42, 278n63
- Mengelberg, Misha, 192, 195, 230, 231, 262, 292n338, 295n444
- Menotti, Gian Carlo, 141
- Mens en Melodie*, 72, 178, 187, 190
- Menuhin, Yehudi, 47
- Messiaen, Olivier, 88, 116, 174, 285n74, 293n357, 293n376
- Messiaen: *Timbres-Durées*, 293n357, 293n376
- Metzger, Heinz-Klaus, 254, 255
- Meulen, M. J. C. van der, 272n112
- Meulen, John van der, 74
- Meyer-Eppler, Werner, 61, 174–176, 179, 186, 247, 248, 250, 273n161, 283n14
- Michaux, Henri, 116
- Middleton, Sam, 234
- Miller, James Arthur, 26
- Miller Broadcasting Company, 26
- Moesman, Joop, 233

- Mol, Hendrik, 204–206, 232  
Mondriaan, Piet, 210  
Monti, Vittorio, 63: *Czárdás*, 63  
*Monument voor een gestorven jongen*, 245, 246, 292n350  
Mood Engineering Society (MES), 15, 230, 231, 233, 234, 245, 262, 292n338  
Moonen, Jan, 93  
Motte-Haber, Helga de la, 280n127  
Mul, Jan, 190  
Mulisch, Harry, 195  
Multivibrator, 63, 64, 67, 69, 177  
Museum Boijmans, 105, 277n14  
music laboratory, 38, 40, 50  
musicology, 201, 203, 205, 213, 215, 226, 246  
Musik und Elektroakustik conference, 60, 86, 97  
Musikalisches Nachtprogramm, 81  
*musique concrète*, 7, 9, 11, 12, 15, 79, 84, 116, 118, 119, 171, 174, 179, 180, 186–188, 209, 234, 247, 285n74, 289n210, 293n357, 293n376
- National Ballet of Canada, 91  
Nederlands Ballet, 67, 182  
Nederlands Fotomuseum, 159  
Nederlandse Christelijke Radio Vereniging (NCRV), 27, 175, 234  
Nederlandse Radio Unie (NRU), 64–67, 70, 131, 140, 175, 176–179, 182, 184, 187, 191, 192, 201, 206, 226, 230, 283n14, 285n73  
Nederlandse Televisie Stichting, 287n158  
Netherlands Ministry of Education, Arts and Sciences, 98, 189, 203, 223  
Netherlands Organisation for Applied Scientific Research (TNO), 120  
Neumann KM54 microphone, 92  
New Music Society, 139  
Nilsson, Bo, 252, 285n69, 294n398  
NIR. See Belgian National Institute for Radio Broadcasting  
noise generator, 63, 69, 175, 191, 199, 206, 263  
Nono, Luigi, 285n74, 293n376: *Epitaffio per Federico García Lorca No. 1*, 293n376; *Incontri*, 285n74  
Nordwestdeutscher Rundfunk (NWDR), 13, 81, 174, 273n161  
Notre Dame du Haut chapel Ronchamp, 103, 106, 115, 169, 170, 278n40  
Numann, Sies W., 24, 43, 47, 72, 74, 142, 143, 270n27  
Nureyev, Rudolf, 246
- Odé, Jan, 204, 205  
ondes Martenot, 41, 61, 76, 78, 79, 83, 115, 208, 271n81, 272n120  
optical siren, 33, 35, 69, 177, 271n59  
Orchestre National de l'ORTF, 116  
Orthel, León, 197
- Paap, Wouter, 72, 178, 188, 190, 284n27  
Pal, George, 72, 74  
Pal Studio, 72, 275n209  
*Paleontologie*, 193, 275n221  
Passchier, H., 175  
Paul Sacher Foundation, 133, 140  
Pauwert, Henri Eduard van den, 102  
Paz & Silva, 18
- Peekel: 230R noise generator, 263; function generator, 191, 199, 236, 237; noise generator, 191, 199, 206; sine wave generator, 191, 199; TF273 third-octave filter, 199, 200, 237; TF296 third-octave filter, 286n125; TF823 multi-octave filter, 191, 199, 237  
perfo tape; perforated tape; perfo master, 151, 155, 162, 163, 165, 166, 168, 282n214; TF824, 263  
Petit, Jean, 153, 167, 281n177  
*Phi-garo in het woud*, 73  
Philadelphia Academy of Music, 42  
Philadelphia-Washington experiment, 271n71  
Philibassist, 62  
Philicord, 62, 63, 67, 70, 273n171  
Philimil film, 26, 28, 31, 32, 43  
Philologist, 36, 62, 288n198  
Philips, Anton Frederik, 18  
Philips, Frits, 42, 142, 143, 182  
Philips Bedrijfs Omroep (PhiBO), 11, 78  
Philips Disques France, 144, 153, 281n185  
Philips ELA, 11, 58, 77, 102, 105–109, 111, 124, 131, 133, 144, 151, 152, 187, 192, 273n140, 274n197, 277n10, 279n104, 294n428  
Philips Experimentele Televisie (PhET), 74  
Philips Fidelio, 36  
Philips Hoofd Industrie Groepen (HIGs), 43, 106  
Philips Lichtadvies Bureau (LiBu), 102  
Philips Ontspanningsgebouw, 36, 54, 58, 71, 285n53  
Philips Pavilion (1958 Brussels World's Fair), 7, 10, 11, 14, 18, 21, 23, 30, 77, 102, 103, 105–107, 109, 111–117, 119–125, 131, 133, 134, 136, 147, 151–153, 157–159, 162–164, 167–171, 187, 190, 220, 269n7, 271n88, 273n140, 281n188, 284n47  
Philips Pavilions (1935 Brussels World's Fair), 102, 103  
Philips Research Laboratories, 9, 10, 12, 14, 15, 17–19, 21–24, 27, 33, 35, 37, 38, 42, 45, 53, 57, 58, 62–64, 67, 69, 70, 72, 74, 77, 81, 82, 88, 90, 92, 95–97, 99, 101, 106, 107, 124, 131, 149, 175, 177, 179, 183, 185, 187, 194, 200, 209, 220, 227, 238, 242, 252, 272n120, 273n140, 275n242, 276n277, 284n24, 285n81, 286n104  
Philips Schouwburg, 182, 183, 237, 284n53  
Philips-Miller, 26–28, 30–33, 43–46, 52, 55, 72, 107, 108, 270n42, 272n92  
*Philips-Radio*, 24, 25  
Philips, Société Anonyme, 113  
Philips' Modern Music Series, 170  
Philips' Phonographic Industries (PPI), 47, 80, 87, 118, 119, 131, 148, 149, 226, 273n169, 278n63  
Philips: 10040 tape recorder, 70; 9710M loudspeaker, 21, 71, 76, 79, 132, 237, 269n13; 9762/00 loudspeaker, 126; DP70 film projector, 109; EL3501 tape recorder, 70; EL3505 tape recorder, 144, 274n197; EL3507 tape recorder, 144, 274n197; EL3509 tape recorder, 76, 79, 131, 132, 144, 208, 274n197; EL3516 tape recorder, 79, 208; EL3800 mixing desk, 131–133, 151, 152, 279n105; EL6040 microphone, 131, 132; EL6471 amplifier, 131; EL6910 electronic reverberation system, 58, 59, 69, 70, 131, 135; GM2307 sine wave generator, 35, 55, 67, 69, 199, 206; GM2308 sine wave generator, 131, 132; GM2314 impulse/sawtooth generator, 131, 132, 208; GM2315 sine wave generator, 69, 76, 79, 131, 132, 279n105; GM5655 oscilloscope, 79, 191; GM5659 oscilloscope, 76, 131, 132;

- Studio Magnetophon 10039 / 10039 tape recorder, 55, 56, 67, 69, 76, 79, 144, 199, 200, 206, 274n197
- Philisonor film projector, 24
- Pijper, Willem, 47, 53, 64, 198, 262, 296n438
- PiLE, 261
- POD, 261
- Point Park College Pittsburgh, 224, 226, 246
- Polet, Sybren, 193
- Polygoon Profilti, 93
- Pomare, Eleo, 233, 234
- Ponse, Luctor, 260, 289n239: *Etude I*, 289n239
- Porcelijn, David, 262
- Poulin, Jacques, 61
- Pousseur, Henri, 182, 186, 205, 224, 250, 286n74, 294n390: *Séismogramme I*; *Séismogrammes*, 182, 294n390
- Prix Italia, 66, 67, 87, 175, 177, 180, 195
- Project 1, 253, 254, 259, 260, 295n431
- Project 2, 261
- pulsating sphere, 86
- punched tape technique, 87
- puppetoons, 72
- Purcell, Henry, 106: *Abdelazar*, 106
- Raaijmakers, Dick, 9, 11–15, 63, 67, 68, 76–80, 82, 83, 86–95, 98, 99, 131, 152, 183, 184, 187, 192–195, 197, 207–210, 212–215, 217, 218, 230–233, 235–245, 252, 257, 262–265, 272n120, 275n228, 275n242, 276n263, 276n277, 286n104, 286n113, 291n280, 291n317, 292n332, 292n345, 294n427: *Cahier "M"*, 241–242; *Contrasts*, 91, 93, 286n104; *Klankstudie over één motief*, 195, 286n104; *Mechanical Motions*, 94, 210; "Night Train Blues," 11, 78, 79, 89, 102, 183, 275n227; *Pianoforte*, 91, 92, 231, 233, 265; "Song of the Second Moon," 11, 78–80, 89, 102, 177, 183, 184, 193; *Tweeklank*, 90, 91, 93, 286n104; *Vijf canons*, 92, 240, 242; *Vijf plastieken*, 91, 92, 210
- radiating wall, 86
- Radio Bremen, 249
- Radio Diffusion Française, 184
- Radio Nederland Wereldomroep, 223
- Radio Valve Revolution*, 72
- Raucamp, Gerard J., 76
- RAVAG tape recorder, 206, 287n152
- Reeser, Hendrik Eduard, 178, 203, 204, 213, 215, 216, 225, 226, 257, 261, 294n426
- Reger, Max, 65
- Reinink, Hendrik Jan, 189, 285n83
- research laboratory for the arts, 196, 197
- reverberation; reverb, 10, 11, 14, 28, 29, 41, 42, 49, 51, 54–61, 69–71, 77, 86, 90, 97, 98, 104–107, 109, 110, 121–123, 127, 130, 131, 133–135, 141, 147–149, 151, 155, 158, 174, 175, 183, 198, 210, 212, 223, 236, 237, 239, 240, 242, 256, 263, 270n29, 273n144, 279n112
- reverberation meter, 54
- Reys, Rita, 80
- Rheinisch-Westfälisches Institut für instrumentelle Mathematik, 253
- RIAS Berlin, 249
- ribbon microphones, 25, 47, 52
- Ridder, Willem de, 230, 231
- Riedl, Joseph Anton, 87
- Rietveld, Jan, 197, 286n111
- Righarts, Jan, 194, 195, 286n104: *Jan Klaassen*, 195, 286n104
- Rijksakademie voor Beeldende Kunsten, 83
- ring modulator, 69, 131, 132, 175, 191, 208, 223, 263, 295n453
- Rinia, Herre, 18, 62
- Rode & Schwarz Abstimmbarer Anzeigeverstärker UBM, 263
- Rodenko, Paul, 195
- Room 306, 67, 72, 76–79, 81, 101, 102, 177, 284n24
- Rowold, Bep, 80
- Royal Conservatoire (The Hague, Netherlands), 13, 197, 235, 262–265, 286n116, 292n317, 295n452
- Royal Dutch Shell Group, 193
- Ruttmann, Walter, 15: *Weekend*, 15
- Sala, Oskar, 61
- Salle des Illusions, 239, 240, 292n329
- Sargent, Malcolm, 106
- Sartory, Karel, 104, 105
- Schaeffer, Pierre, 7, 61, 97, 116, 179, 182, 186–188, 209, 234, 247, 248, 254, 293n357: *Symphonie pour un homme seul*, 247, 248, 293n357; *Orphée* 53, 188, 247, 293n357
- Schat, Peter, 87, 176, 178, 191, 192, 195, 204, 217, 230, 231, 262, 285n92, 288n204: *De Aleph*, 285n92; *Studie*, 217, 288n204
- Scherchen, Hermann, 59, 60, 86, 116, 136, 153, 247, 250, 254, 276n253
- Schierbeek, Bert, 197
- Schoenberg, Arnold, 65, 115, 262, 274n193, 285n74
- Schöffner, Nicholas, 83, 84, 144: projections spatio-dynamiques, 144; Spatiodynamic Tower, 83, 84, 144 Schouten, Jan Frederik, 21, 33
- Schuitema, E. B. W., 118, 119, 278n65
- Schütz, Heinz, 250, 251
- Scriabine, Marina, 186
- selective amplifier, 162, 163, 165
- Serenata Nocturna*, 73
- serial composition; serial composition technique; serialism, 71, 88, 92, 186, 220, 229, 247, 253, 256, 257, 262
- Siemens Oktavsieb filter, 199
- Skymasters, the, 80, 81, 210, 211, 227, 287n164
- Small Faces, 292n342
- Société de Travail en Béton (Strabed), 126
- Société Nationale des Architectes Français, 103
- son et lumière*, 111–114, 118, 120, 122, 144, 158, 271n88, 280n157
- sound-projection, 49
- South Pacific*, 109
- Spaens, Charles, 123, 142, 143
- spatialization; spatiality, 14, 15, 131, 133, 134, 154, 155, 157, 158, 168, 187, 195, 197, 231, 289n219
- Spek, Jaap, 197, 199, 200, 212, 214, 217, 230, 231, 234, 236–238, 240, 244, 254, 257, 264, 287n113, 291n280, 292n317, 294n427: *Impulsen*, 200, 217, 231, 234
- Sputnik, 78
- SSP, 261
- Staatliche Hochschule für Musik Cologne, 249, 255
- Staatliche Hochschule für Musik Stuttgart, 224
- Stadsschouwburg Amsterdam, 71, 197, 286n110, 286n117
- Stadsschouwburg Utrecht, 231



- Stam, Henk, 173, 174, 176, 178, 182, 186, 188  
 Starink, Jan, 65  
 Stedelijk Museum Amsterdam, 105, 234, 243  
 Stehman, Jacques, 141  
 stereo; stereophonic; stereophony, 14, 28–33, 45–49, 51–54, 56, 70, 71, 77, 86, 91, 103–107, 109, 112, 113, 116, 122, 123, 131, 133, 147–149, 150, 151, 155, 156, 191, 221, 242, 270n44, 270n49, 278n46, 281n178, 284n35  
 Stichting Radio Nederland, 33, 77  
 Stockhausen, Karlheinz, 7, 12–14, 71, 72, 89, 117, 174, 179, 182–184, 186, 188, 205, 219, 220, 223, 224, 226, 236–238, 247, 250, 252–254, 264, 281n168, 283n7, 284n34, 285n74, 294n405, 295n453: "... wie die Zeit vergeht...", 238; *Gesang der Jünglinge*, 71, 179, 183, 186, 187, 220, 237, 252, 254; *Gruppen für drei Orchester*, 89; *Kontakte*, 237, 238, 244, 252–254, 281n168, 292n317; *Kontra-Punkte*, 285n74; *Mikrophonie I*, 264, 295n453; *Mikrophonie II*, 295n453; *Studie I*, 174, 283n7; *Studie II*, 182, 294n390  
 stokophonie; stokophonics, 43, 49, 53  
 Stokowski, Leopold, 14, 39, 40–51, 53, 55, 62, 106, 271n71, 271n83, 272n92, 272n125: *Music for All of Us*, 40–42, 49, 55  
 Stokowski installation, 43–45, 53  
*Story in the Rocks*. See *Paleontologie*  
 Stotijn, Herman, 80  
 Strate, Grant, 91  
 Stratford Shakespearean Festival, 91  
 Stravinsky, Igor, 115, 271n83, 272n125, 285n74: *The Rite of Spring*, 271n83, 272n125; *Threni, id est Lamentatio Jeremiae*, 285n74  
 Strijbosch, Wim, 194  
 Strijp III; Strijp R, 102, 124, 130–132, 135, 145, 146, 148, 279n82, 279n105  
 Studio for Electro-Instrumental Music (STEIM), 192  
 Studio voor Elektronische Muziek (STEM), 12, 13, 99, 198, 209, 212–219, 223–226, 230–233, 235, 236, 243, 246, 247, 255–257, 260, 261, 263, 264, 274n197, 285n92, 286n125, 287n158, 291n282, 294n397, 294n426, 294n428, 295n435  
 Süddeutscher Rundfunk (SDR), 249  
 Südwestfunk (SWF), 90, 278n51  
 Symphonieorchester des Bayerischen Rundfunks, 116  
 synthetic sound, 33, 34, 65, 145, 174, 247  
 Tajiri, Shinkichi, 233, 234  
 Tak, Willem, 54, 107, 120–126, 130, 131, 133, 137, 141, 142, 144–147, 149, 155, 157, 158, 163, 166–168, 273n140, 280n125, 280n149, 281n195, 282n211  
 tape loop; tape loop recorder/player, 78, 79, 82, 83, 131, 208, 224  
 Tazelaar, Kees: *K12*, 289n239  
 Teatro alla Scala Milan, 14, 58, 105  
 Technische Hogeschool (TH) Delft, 12, 13, 18, 35, 64, 65, 177–180, 188–196, 198–201, 203–206, 209, 212, 213, 217, 222, 231, 232, 234–237, 270n47, 271n71, 285n89, 285n90, 286n103, 286n104, 290n279, 291n299, 295n444 (also studio in Delft or Delft studio)  
 Technische Universität Berlin, 186  
 Teer, Kees, 95, 96, 98, 274n175  
 Telcom, 44  
 Telefunken, 55, 59  
 Telefunken: loudspeaker columns, 90; M5 tape recorder, 191; M23 tape recorder, 206, 230; time delay unit, 60  
 Tempelaars, Stan, 261  
 ten Hacken, Huub. See Hacken, Huub ten  
 Termen, Lev, 271n80  
 Tharichen, Werner: *Musik auf Pauken*, 186  
*The Conquered Planet*, 15, 74–76, 193, 283n16  
*The Cool Voice of Rita Reys* No. 2, 80  
*The ELAgraph*, 109  
*The Empire Builders*, 197, 236  
 The Hague Philharmonic, 58, 80  
*The Haunted Castle*, 73  
*The Long Christmas Dinner*, 199, 204, 286n123  
*The Magic Music*, 73  
*The Reality of Karel Appel*, 218  
*The Ship of the Ether*, 72  
 Theater Tuschinski, 25, 195  
 Théâtre des Champs-Élysées, 116  
 Théâtre Sarah-Bernhardt, 84  
 Theologisch Instituut, 261  
 theremin, 41, 115, 271n80  
 Todd-AO, 109  
 Tomasi, Henri, 47, 143, 144, 280n156, 280n157, 284n47  
 Tombe, J. H. des, 98, 201, 203, 204, 209, 213–218, 224, 225, 247, 255–257, 261, 294n426  
 Tomek, Otto, 253  
 tone gate, 199, 224, 237, 289n235  
 tone-operated gain-adjusting device (TOGAD), 42  
 Toneelgroep Studio, 197, 234, 236  
 Toneelwerkgroep Test, 14, 193–197, 220, 286n103, 286n104, 286n110  
 Tonographie H83B impulse generator, 263  
 Toonder, Marten, 72  
 Toonder Studios, 15, 73–75, 193, 275n221  
 transcription disc, 46  
 trauttonium, 61, 180, 248, 273n162  
 Trautwein, Friedrich, 61, 247, 250, 273n162  
 Treib, Marc, 11, 277n7, 280n150, 281n183: *Space Calculated in Seconds*, 11  
 Truax, Barry, 261  
 Tubbs, Ralph, 103  
 twelve-tone  
     composition/material/music/nonsense/piece/rows/  
     technique, 65, 81, 178, 198, 207, 210, 211, 227, 232, 249, 253, 262, 274n193, 284n27  
*Two Lovers*, 22  
 Ulsen, Henk van, 193  
 Union Internationale de Radiodiffusion, 26  
 Unité d'Habitation Marseille, 84, 85, 115, 169  
 University of Adelaide, 224  
 University of Amsterdam, 179, 203–206, 232, 235  
 University of Bonn, 13, 253, 254, 257  
 Urk, Arend Thomas van, 18  
 Ussachevsky, Vladimir, 79, 80, 182, 232  
 Utrecht University, 98, 200, 201, 203–205, 207–209, 213, 216, 224, 226, 246, 257, 261, 294n428  
 Utrechts Conservatorium, 232, 262, 291n290  
 uviol, 121  
 van Baaren, Kees. See Baaren, Kees van  
 van Beinum, Eduard. See Beinum, Eduard van  
 van Bergeijk, Gilius. See Bergeijk, Gilius van  
 van de Weetering, Conrad. See Weetering, Conrad van de

- van den Pauwert, Henri Eduard. *See* Pauwert, Henri Eduard van den
- van der Kooy, Tymen. *See* Kooy, Tymen van der
- van der Meulen, M. J. C. *See* Meulen, M. J. C. Van der
- van der Meulen, John. *See* Meulen, John van der
- van Dijk, Piet. *See* Dijk, Piet van
- van Dongen, Theo. *See* Dongen, Theo van
- van Doorn, Frans. *See* Doorn, Frans van
- van Ginneken, Jaap. *See* Ginneken, Jaap van
- van Hall, Marleen. *See* Hall, Marleen van
- van Hemel, Oscar. *See* Hemel, Oscar van
- van Iersel, Kees. *See* Iersel, Kees van
- van Kuilenburg, Wim. *See* Kuilenburg, Wim van
- van Ulsen, Henk. *See* Ulsen, Henk van
- van Urk, Arend Thomas. *See* Urk, Arend Thomas van
- van Vlijmen, Jan. *See* Vlijmen, Jan van
- van Woerkom, Theo. *See* Woerkom, Theo van
- Vancoppenolle, Paul, 164, 165, 282n212
- Varèse, Edgard, 7, 9, 11, 35, 41, 49, 77, 88, 97, 99, 101, 102, 109, 111, 114–120, 124–127, 130–134, 136, 139–147, 149, 151–157, 159, 166–171, 183, 184, 186, 187, 190, 254, 271n80, 278n46, 278n65, 280n136, 281n162, 281n176, 282n202, 283n231, 285n74, 294n428; *Amériques*, 41; *Densité 21.5*, 119, 285n74; *Déserts*, 115–117, 119, 140, 147, 171, 184, 186, 187, 278n46; *Equatorial*, 41, 115, 271n80; *Espace*, 139; *Étude pour espace*, 139, 140, 145, 146, 280n127; *Hyperprism*, 41; *Intégrales*, 41, 119, 190; *Ionisation*, 119; *Octandre*, 119
- Varèse, Louise, 142, 144, 145, 152, 280n145, 280n149, 281n175, 282n227, 283n231
- Veemgebouw (Philips), 107
- Vereeniging van Arbeiders Radio Amateurs (VARA); Omroepvereniging VARA, 54, 72, 82, 222, 275n208
- Vermaak, Elbert, 176
- Vermeulen, Roelof, 10–12, 14, 18, 21–23, 25, 36–41, 43–56, 59–63, 66, 67, 70, 71, 76–81, 86–90, 95–99, 101–107, 122, 124, 131, 152, 174–182, 187, 192, 200, 206, 209, 212–215, 217, 218, 220, 230, 232, 236, 238, 242, 271n64, 272n115, 272n120, 273n165, 276n253, 277n3, 286n103, 288n198
- Vermeulen, Joke, 86
- Verschoor, W., 236, 237, 241, 263
- Verwey, Evert, 18
- Vesseur, Wim, 197
- Vian, Boris, 197, 236
- Vink, Jaap, 206, 207, 222, 223, 287n150, 287n158
- Vitaphone, 22, 23
- Vlijmen, Jan van, 178, 192, 257, 262, 265, 295n444
- Von Karajan, Herbert. *See* Karajan, Herbert von
- VOSIM, 261
- Vries, Frank de, 257, 261, 263
- Vrijman, Jan, 218
- Wandel & Goltermann third-octave filter, 67, 69, 76, 131, 132
- Wansdronk, Cees, 63
- Warner Bros., 22
- Webern, Anton, 97, 179, 285n74
- Weetering, Conrad van de, 198, 286n117
- Weiland, Frits, 209, 217, 218, 226, 287n158
- Wen-chung, Chou, 140, 141, 282n202
- Westdeutscher Rundfunk (WDR), 71, 183, 184, 186, 237, 253–255, 264
- Western Electric, 22
- Wever, Peter, 162, 280n159, 282n212
- Wiegersma, Hendrik, 105
- Wiener Radiowerke AG (WIRAG), 144, 287n152
- Wiener Sängerknaben, 144
- Wijdeveld, Wolfgang, 232
- Wilde, Oscar, 249
- Wilder, Thornton, 199
- Wisse, Jan, 262, 276n257
- Woerkom, Theo van, 66, 226
- Wolf, Christian, 285n74
- World Wide Pictures, 94
- Wylam, Ric, 94
- Xenakis, Iannis, 7, 11, 87, 101, 115–121, 125, 126, 130, 134, 136–138, 141–143, 153–159, 166, 167, 169, 186–188, 226, 276n251, 281n185, 281n195; *Analogique B*, 87; *Concret PH*, 153, 281n178; *Diamorphoses*, 186, 188; *Interlude sonore*, 153–156, 167, 169; *Metastaseis*, 116; *Pithoprakta*, 116
- Yeats, William Butler, 65, 286n102
- Zaalberg van Zelst, J. J., 214
- Zadkine, Osip, 103, 105, 106, 116; *La ville détruite*, 105
- Zeilen, 218
- Zielstra, Jan, 274n203
- Zimmermann, Bernd Alois, 255; *Perspektiven*, 255
- Zupko, Ramon, 289n238, 289n239; *Transients*, 289n239

Also by V2\_Publishing

*Dick Raaymakers: A Monograph*  
Edited by Arjen Mulder and Joke Brouwer

*Dick Raaijmakers: Monografie*  
Edited by Arjen Mulder and Joke Brouwer

*Everyone Is an Artist*  
Ruben Jacobs

*Een stuk van mij gaat een paar keer*  
Arjen Mulder

*Wat is community art?*  
Arie Altena

*Art and Autonomy*  
Sebastian Olma

*Artonauten*  
Ruben Jacobs

*Participatieve kunst*  
Sandra Trienekens

[www.v2.nl/publishing](http://www.v2.nl/publishing)

# Colophon

Editors: Joke Brouwer, Arjen Mulder  
Copy editor: Laura Martz  
Production and design: Joke Brouwer  
Cover design: Jan Heijnen

This publication was financially supported by Société Gavignières and the Royal Conservatoire in The Hague. The digital version was financially supported by Société Gavignières and the Konrad Boehmer Foundation.

© 2013, 2020 Kees Tazelaar and V2\_Publishing, Rotterdam.

For works of visual artists affiliated with a CISAC-organization the copyrights have been settled with Pictoright in Amsterdam.  
© 20XX, c/o Pictoright Amsterdam

Although every effort was made to find the copyright holders for the illustrations used, it has not been possible to trace them all. Interested parties are requested to contact V2\_Publishing, Eendrachtsstraat 10, 3012 XL Rotterdam, the Netherlands.

All rights reserved. No part of this publication may be reproduced, stored in a retrieval system, or transmitted in any form or by any means, electronic, mechanical, photocopying, recording or otherwise, without the prior written permission of the publisher.

ISBN 978-94-6208-065-2

For music excerpts and other references, see: [www.thresholdofbeauty.com](http://www.thresholdofbeauty.com)

<http://www.v2.nl/publishing>

*On the Threshold of Beauty: Philips and the Origins of Electronic Music in the Netherlands, 1925–1965* is an extremely well-documented, lavishly illustrated and highly readable study. Based on new and original research, it serves the needs of both specialists and a lay audience. It describes a period of musical history in which an entirely new world of electronic sounds and compositional attitudes was developed and explored, ranging from avant-garde extremes to the earliest experiments in electronic pop; from the music for the iconic Philips Pavilion at the 1958 World's Fair to electronic soundtracks for film.

The author brings a composer's sensibility to an in-depth understanding of the conceptual frameworks of electronic music as it came about in commercial companies' labs, scientific settings and private studios. He looks at the pioneering work of **Henk Badings, Jan Boerman, Ton Bruynèl, Tom Dissevelt, Gottfried Michael Koenig, Ton de Leeuw, Walter Maas, Dick Raaijmakers, Hermann Scherchen, Leopold Stokowski, Edgard Varèse** and **Roelof Vermeulen**.

**Kees Tazelaar** is a composer of electroacoustic music and heads the Institute of Sonology at the Royal Conservatoire in The Hague, the Netherlands.

