



Sega Amusements Europe Limited.
42 Barwell Business Park, Leatherhead Road, Chessington, Surrey, KT9 2NY. United Kingdom.
Telephone: +44 (0) 208 391 8090 Facsimile: +44 (0) 208 391 8099
email: mailbox@sega.co.uk Web: <http://www.segaarcade.com>

Sega Games Co., Ltd. 1-2-12, Haneda, Ota-ku, Tokyo, 144-8531. Japan.
Telephone: +81-3-5736-7111 Facsimile: +81-3-6871-7672
sega-games.co.jp

© SEGA

Errors and omissions excepted (E&OE)

TARGET BRAVO: OPERATION GHOST

OWNER'S MANUAL

420-0029-00K



OPERATOR & SERVICE MANUAL

TARGET_BRAVO

OPERATION G.H.O.S.T.



IMPORTANT

- Before using this product, read this manual carefully to understand the contents indicated in this document.
- After reading this manual, be sure to keep it near the product or in a convenient location for easy reference when needed.

TARGET BRAVO

Before using this product, be sure to read the following

To maintain safety:

To ensure the safe operation of this product, be sure to read the following before usage.

The following instructions are intended for the users, operators and the personnel in charge of the operation of the product. After carefully reading and sufficiently understanding the warning displays and cautions, handle the product appropriately. Be sure to keep this manual close to the product or in a convenient place for future reference.

Herein, explanations which require special attention are enclosed with dual lines. Depending on the potentially hazardous degrees, the terms of DANGER, WARNING, CAUTION, etc. are used. Be sure to understand the contents of the displays before reading the text

 **DANGER** Indicates that mishandling the product by disregarding this pictograph will cause severe injury or death.

 **WARNING** Indicates that mishandling the product by disregarding this warning will cause a potentially hazardous situation which can result in death or serious injury.

 **CAUTION** Indicates that mishandling the product by disregarding this caution will cause a slight hazardous situation which can result in personal injury and/or material damage.

For the safe usage of the product, the following pictographs are used:



Indicates "HANDLE WITH CARE." In order to protect the human body and equipment, this display is attached to places where the instruction manual should be referred to.



Indicates a "protective earth terminal." Before operating the equipment, be sure to connect it to the ground.
(The step may be omitted for products in which a power cable with earth is used.)

- **Perform work in accordance with the instructions herein stated.**

Instructions for work are explained by paying attention to the aspect of accident prevention. Failing to perform work as per the instructions can cause accidents. In the case where only those who have technical expertise should perform the work to avoid hazardous situation, the instructions herein state that the site maintenance personnel should perform such work.

- **Be sure to turn off the power before working on the machine.**

To prevent an electric shock, be sure to turn off the power and unplug the power cable before carrying out any work that requires direct contact with the interior of the product. If the work is to be performed in the power-on status, the instruction manual herein always states to that effect.

- **Be sure to ground the earth terminal.**

- **(This is not required in the case where a power cable with earth is used.)**

This product is equipped with the earth terminal. When installing the product, connect the earth terminal to the "accurately grounded indoor earth terminal" by using an earth wire. Unless the product is grounded appropriately, the user can be subject to an electric shock. After performing repair, etc. for the control equipment, ensure that the earth wire is firmly connected to the control equipment.

Ensure that the power supply used is equipped with an earth leakage breaker. Using a power supply which is not equipped with the earth leakage breaker can cause a fire when earth leakage occurs.

**Be sure to use fuses which meet the specified rating.
(Only for the machines which use fuses.)**

- Using fuses exceeding the specified rating can cause a fire and an electric shock.

- **Specification changes (removal of equipment, conversion and addition) not designated by SEGA are not allowed.**

The parts of the product include warning labels for safety, covers for personal protection, etc. It is very hazardous to operate the product by removing parts and/or modifying the circuits. Should doors, lids and protective parts be damaged or lost, refrain from operating the product, and contact where the product was purchased from or the office herein stated.

SEGA shall not be held responsible for any accidents, compensation for damage to a third party, resulting from the specifications not designated by SEGA.

- **Ensure that the product meets the requirements of appropriate electrical specifications.**

Before installing the product, check for electrical specifications. SEGA products have a nameplate on which electrical specifications are described. Ensure that the product is compatible with the power supply voltage and frequency requirements of the location. Using any electrical specifications different from the designated specifications can cause a fire and an electric shock.

- **Install and operate the product in places where appropriate lighting is available, allowing warning labels to be clearly read.**

To ensure safety for the customers, labels and printed instructions describing potentially hazardous situations are applied to places where accidents can be caused. Ensure that where the product is operated has sufficient lighting allowing the warnings to be read. If any label is peeled off, apply it again immediately. Please place an order with where the product was purchased from or the office herein stated.

When handling the monitor, be very careful. (Applies only to products with monitors.)

- Some of the monitor parts are subject to high tension voltage. Even after turning off the power, some portions are still subject to high tension voltage sometimes. Monitor repair and replacement should be performed only by those technical personnel who have knowledge of electricity and technical expertise.

Be sure to adjust the monitor properly. (Applies only to products with monitors.)

Do not operate the product leaving on-screen flickering or blurring as it is. Using the product with the monitor not properly adjusted may cause dizziness or a headache to an operator, a player, or the customers.

- **When transporting or reselling this product, be sure to attach this manual to the product.**

- * *In the case where commercially available monitors and printers are used in this product, only the contents relating to this product are explained herein. Some commercially available equipment has functions and reactions not stated in this manual. Read this manual together with the specific instruction manual of such equipment.*
- * *Descriptions herein contained may be subject to improvement changes without notice.*
- * *The contents described herein are fully prepared with due care. However, should any question arise or errors be found, please contact SEGA.*

INSPECTIONS IMMEDIATELY AFTER TRANSPORTING THE PRODUCT TO THE LOCATION

Normally, at the time of shipment, SEGA products are in a status allowing for usage immediately after transporting to the location. Nevertheless, an irregular situation may occur during transportation. Before turning on the power, check the following points to ensure that the product has been transported in a satisfactory status.

- Are there any dented portions or defects (cuts, etc.) on the external surfaces of the cabinet?
- Are casters and adjusters damaged?
- Do the power supply voltage and frequency requirements meet with those of the location?
- Are all wiring connectors correctly and securely connected? Unless connected in the correct way, connector connections can not be made accurately. Do not insert connectors forcibly.
- Do power cables have cuts and dents?
- Are all accessories available?
- Can all doors and lids be opened with the accessory keys? Can doors and lids be firmly closed?

INTRODUCTION

This manual is intended to provide detailed descriptions together with all necessary information covering the general operation of electronic assemblies, electromechanical, servicing control, spare parts, etc. for the product, "TARGET BRAVO: OPERATION G.H.O.S.T."

This manual is intended for the owners, personnel managers in charge of operation of this product. Operate the product after carefully reading and sufficiently understanding the instructions.

In the unlikely event that the product does not function correctly, DO NOT allow anyone other than a technician to touch the internal system. Turn off the power to the machine, making sure to unplug the electrical cord from the outlet, and contact the office listed below or the point-of-purchase for this product.

Use of this product is unlikely to cause physical injuries or damage to property. However, points that require special attention are indicated by bold text, the words "STOP, IMPORTANT or CAUTION" and the symbols below.

IMPORTANT

Indicates important information that, if ignored, may result in the mishandling of the product and cause faulty operation or damage to the product.

WARNING **CAUTION**

Indicates a warning or caution that, if ignored, may result in the mishandling of the product and cause faulty operation or damage to the product.

Sega Amusements International Limited.

42 Barwell Business Park, Leatherhead Road, Chessington, Surrey, KT9 2NY. United Kingdom.

European Sales:	+44 (0) 208 391 8090	Facsimile:	+44 (0) 208 391 8099
USA Sales:	+00 (1) 224 265 4287		
STS (Spares):	+44 (0) 208 391 8060	Facsimile:	+44 (0) 208 391 8096
email:	mailbox@sega.co.uk	Web:	http://www.segaarcade.com

Definition of 'Site Maintenance Personnel or Other Qualified Individuals



Procedures not described in this manual or marked as 'to be carried out by site maintenance personnel or other qualified professionals' should not be carried out by personnel without the necessary skill or technology. Work carried out by unqualified persons may cause serious accidents, including electrocution.

Parts replacement, maintenance inspections and troubleshooting should be carried out by site maintenance personnel or other qualified professionals. This manual includes directions for potentially dangerous procedures which should only be carried out by professionals with the appropriate specialised knowledge.

The site maintenance personnel or other qualified professionals mentioned in this manual are defined as follows:

Site maintenance personnel:

Individuals with experience in maintaining amusement equipment, vending machines, etc., working under the supervision of the owner/operator of this product to maintain machines within amusement facilities or similar premises by carrying out everyday procedures such as assembly, maintenance inspections, and replacement of units/expendable parts.

Activities to be carried out by site maintenance personnel:

Amusement equipment/vending machine assembly, maintenance inspection and replacement of units/expendable parts.

Other qualified professionals:

Persons employed by amusement equipment manufacturers, or involved in design, production, testing or maintenance of amusement equipment. The individual should have either graduated from technical school or hold similar qualifications in electrical/electronics/mechanical engineering.

Activities to be carried out by other qualified professionals:

Amusement equipment/vending machine assembly, repair/adjustment of electrical/electronic/mechanical parts.

Waste of Electrical and Electronic Equipment (WEEE) Statement.

The WEEE (Waste of Electrical and Electronic Equipment) directive places an obligation on all EU based manufacturers and importers of Electrical and Electronic Equipment to take back products at the end of their useful life. Sega Amusements Europe Ltd accepts its responsibility to finance the cost of treatment and recovery of redundant WEEE in the United Kingdom in accordance with the specified WEEE recycling requirements.

The symbol shown below will be on all products manufactured from 13th August 2005, which indicates this product must NOT be disposed of with other normal waste. Instead, it is the user's responsibility to dispose of their waste equipment by arranging to return it to a designated UK collection point for the correct recycling of waste electrical and electronic equipment.

For more information about where you can send your waste equipment for recycling contact your local authority of-fice.

For non-UK users contact your local authority office for information on the recycling of Waste Electrical and Electronic Equipment.

Battery Recycling Statement.

The EC Directive on Batteries and Accumulators (2006/66/EC) aims to minimise the impact of batteries on the environment and encourage the recovery of the materials they contain. To achieve increased collection and recycling of waste batteries, the Directive places 'producer responsibility' obligations on manufacturers and importers of portable, industrial and automotive batteries.

The symbol shown below will be on all equipment fitted with batteries from 26th September 2008 and indicates they must NOT be disposed of with other normal waste. Instead, it is the user's responsibility to dispose of used batteries by arranging to return them to a designated collection point for the correct recycling.

For more information about where you can send your waste batteries for recycling contact your local authority of-fice.



REGISTERED IN ENGLAND REGISTERED NO. 1711515

REGISTERED OFFICE: BLOCK C 42 BARWELL BUSINESS PARK, CHESSINGTON, SURREY KT9 2NY

■ Licensing

○ Lua:

Copyright © 1994-2017 Lua.org, PUC-Rio.

Permission is hereby granted, free of charge, to any person obtaining a copy of this software and associated documentation files (the "Software"), to deal in the Software without restriction, including without limitation the rights to use, copy, modify, merge, publish, distribute, sublicense, and/or sell copies of the Software, and to permit persons to whom the Software is furnished to do so, subject to the following conditions:

The above copyright notice and this permission notice shall be included in all copies or substantial portions of the Software.

THE SOFTWARE IS PROVIDED "AS IS", WITHOUT WARRANTY OF ANY KIND, EXPRESS OR IMPLIED, INCLUDING BUT NOT LIMITED TO THE WARRANTIES OF MERCHANTABILITY, FITNESS FOR A PARTICULAR PURPOSE AND NONINFRINGEMENT. IN NO EVENT SHALL THE AUTHORS OR COPYRIGHT HOLDERS BE LIABLE FOR ANY CLAIM, DAMAGES OR OTHER LIABILITY, WHETHER IN AN ACTION OF CONTRACT, TORT OR OTHERWISE, ARISING FROM, OUT OF OR IN CONNECTION WITH THE SOFTWARE OR THE USE OR OTHER DEALINGS IN THE SOFTWARE.

○ tolua++ License

tolua++ is based on tolua (www.tecgraf.puc-rio.br/~celes/tolua), and it's licensed under the terms of the MIT license reproduced below.

This means that Lua is free software and can be used for both academic and commercial purposes at absolutely no cost.

○ DYNA Font

The typefaces included herein are solely developed by DynaComware|.

WARNING

- Do not touch undesignated places. Touching places not designated can cause electric shock or short circuit.
- Whenever any fasteners (e.g. screws, nuts) have been lost, be sure to use replacement fasteners with proper dimensions as specified in this manual. If fasteners of any other dimensions are used, it could cause damage and/or separation of parts that result in secondary accidents.
- Specification changes, removal of equipment, conversion and/or addition, not designated by SEGA are not permitted.
- Failure to observe this may cause a fire or an electric shock. Noncompliance with this instruction can have a bad influence upon physical conditions of the players or the onlookers, or result in injury during play.
- SEGA shall not be held responsible for damage, compensation for damage to a third party, caused by specification changes not designated by SEGA.
- Performing work or parts replacements not described in this manual could result in accidents. If you need to perform any work not listed in this manual, request work from the office indicated in this manual or the point-of-purchase, or inquires for details.
- Be sure to perform periodic maintenance inspections herein stated.

IMPORTANT

- For the IC board circuit inspections, only the use of a logic tester is recommended. Using a Multi- Tester or General Purpose Tester may result in damage to IC Circuits.
- Static electricity from your body may damage some electronics devices on the IC board. Before handling the IC board, touch a grounded metallic surface so that the static electricity can be discharged.
- This video gaming cabinet utilises a motorised steering feedback system. Do not attempt to service this part or any other part in close proximity to the steering mechanism whilst power is applied.
- Some parts are not designed and manufactured specifically for this game machine. The manufacturers may discontinue, or change the specifications of such general-purpose parts. If this is the case, SEGA cannot repair or replace a failed game machine whether or not a warranty period has expired.

CONCERNING THE STICKER DISPLAY

This SEGA product has stickers attached describing the product manufacture No. (Serial No.) and Electrical Specifications. It also has a Sticker describing where to contact for repair and for purchasing parts.

When inquiring about or asking for repairs, mention the Serial No. and Name of Machine indicated on the Sticker. The Serial Number indicates the product register. Identical machines could have different parts depending on the date of production. Also, improvements and modifications might have been made after the publication of this manual. In order to ensure you order the correct parts, mention the Serial No. when contacting the applicable places.

CONCERNING WARNING DISPLAYS

This SEGA product has warning displays on stickers, labels and/or printed instructions adhered/attached to or incorporated in the places where a potentially hazardous situation could arise. The warning displays are intended for accident prevention for customers and for avoiding hazardous situations relating to maintenance and servicing work. Some portions of the cabinet contain high voltage and may cause accidents if touched. When performing maintenance, be very careful of the warning displays. It is especially important that any complex repair and replacement work not mentioned herein should be performed by those technical personnel who have knowledge of electricity and technical expertise.

In order to prevent accidents, caution any customer ignoring the warnings to cease and desist immediately.

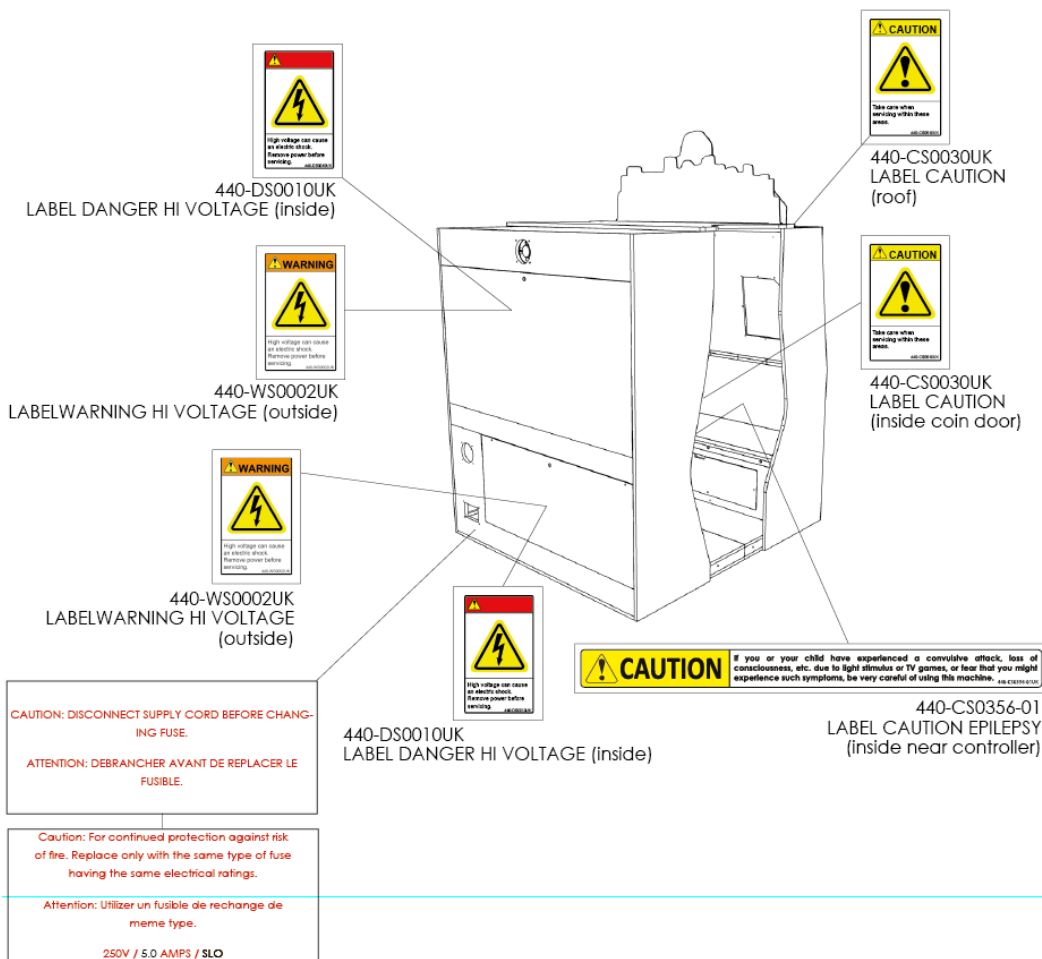

2

PRECAUTIONS REGARDING INSTALLATION

WARNING

- This product is an indoor game machine. Do not install it outside. Even indoors, avoid installing in places mentioned below so as not to cause a fire, electric shock, injury and/or malfunction.
- Places subject to rain or water leakage, or places subject to high humidity in the proximity of an indoor swimming pool and/or shower, etc.
- Places subject to direct sunlight, or places subject to high temperatures in the proximity of heating units, etc.
- Places filled with inflammable gas or vicinity of highly inflammable/volatile chemicals or hazardous matter.
- Dusty places.
- Sloped surfaces.
- Places subject to any type of violent impact.
- Vicinity of anti-disaster facilities such as fire exits and fire extinguishers.
- Areas where the temperature exceeds the applicable temperature (ambient temperature) range of 5 to 30 degrees centigrade.

LIMITATIONS OF USAGE

WARNING

- Be sure to check the Electrical Specifications. Ensure that this product is compatible with the location's power supply, voltage, and frequency requirements. A plate describing Electrical Specifications is attached to the product. Noncompliance with the Electrical Specifications can cause a fire and electric shock.
- This product requires a breaker and earth mechanism as part of the location facilities. Using the product without these can cause a fire and electric shock.
- Ensure that the indoor wiring for the power supply is rated at 15 A or higher (AC single phase 100 V ~ 120 V area), and 7 A or higher (AC 220 V ~ 240 V area). Noncompliance with the Electrical Specifications can cause a fire and electric shock.
- Be sure to use an independent power supply equipped with an earth leakage breaker. Using a power supply without an earth leakage breaker can cause an outbreak of fire if a power surge occurs.
- Putting many loads on one electrical outlet can cause generation of heat and a fire resulting from overload.
- When using an extension cord, ensure that the cord is rated at 15 A or higher (AC 100 V ~ 120 V area) and 7 A or higher (AC 220 V ~ 240 V area). Using a cord rated lower than the specified rating can cause a fire and electric shock.

CAUTION

- To avoid injury, be sure to provide sufficient space by considering the potentially crowded situation at the installation location. Insufficient installation space can cause contact, collisions, and/or trouble between customers.
- During daily cleaning, be sure to check the surface of the control unit and other parts that the player touches with his/her hands for damage, cracks, or loose screws. If a player uses the machine while it is damaged, cracked, or has a loose screw, the player may become injured.

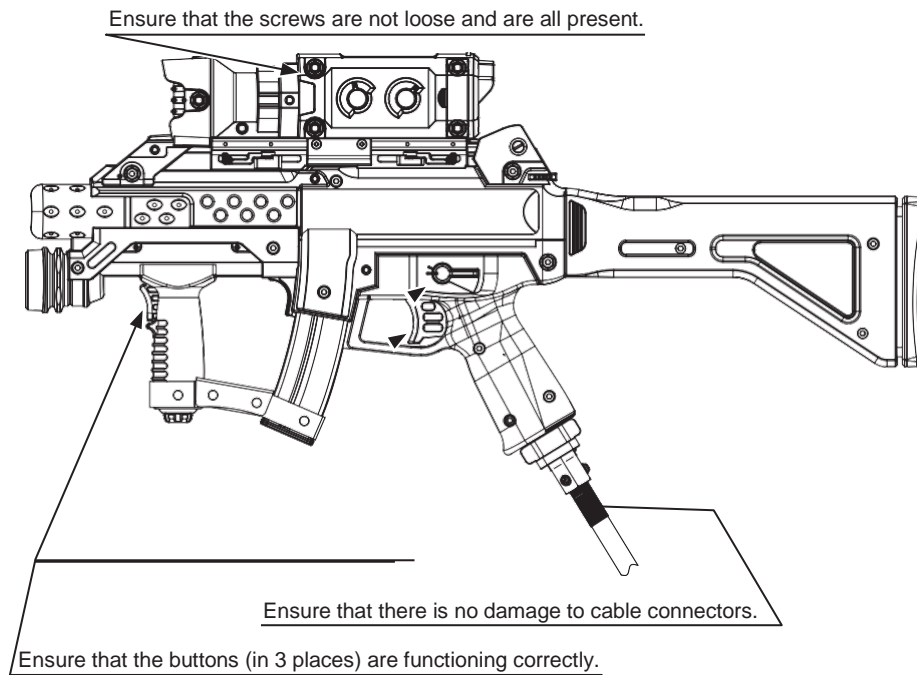

- Check carefully to make sure there are no gaps in the cabinet joints and that they are not loose. If there are gaps or looseness, players may get their hands or fingers caught, resulting in an injury.
- Make sure all the doors are locked securely and that they do not rattle. If the doors are not locked properly or there are gaps or rattling, the players could get their fingers or hands caught. It could also invite mischief.
- Be sure to perform appropriate adjustment of the LCD. For operation of this machine, do not leave monitor's flickering or deviation as is. Failure to observe this can have a bad influence upon the players' or the customers' physical conditions.
- Inspect for the following items during a trial run. If there is any type of error, use the Test Mode, etc., to resolve the problem. If you continue use with an error, it can cause an accident or irreparable parts damage.
 - Is there any strangeness in the operability of the control unit?
 - Is there any improper adjustment of the LCD screen?
- Prepare a place where players can rest if they feel sick.

2-1 PAYING ATTENTION TO CUSTOMERS

To avoid injury and trouble, be sure to constantly give careful attention to the behaviour and manner of the visitors and players.

DURING OPERATION (PAYING ATTENTION TO CUSTOMERS)

WARNING

- For safety reasons, do not allow any of the following people to play the game.
 - Those who have high blood pressure or a heart problem.
 - Those who have experienced muscle convulsion or loss of consciousness when playing video games, etc.
 - Those who have neck or spinal cord problems.
 - Those who are intoxicated or under the influence of drugs.
 - Pregnant women.
 - Those who are not in good health.
 - Those who do not follow the attendant's instructions.
 - Those who cannot grasp the Control Unit securely because of immobility in fingers, hands or arms.
 - Persons who disregard the product's warning displays.

This product is intended for a single player only. Having two or more persons simultaneously playing this product can result to injury to the player and possible damage to the product.

- Even players who have never been adversely affected by light stimulus might experience dizziness or headache depending on their physical condition when playing the game.

Small children are especially likely to experience these symptoms. Caution guardians of small children to keep watch on their children during play.
- Instruct those who feel sick during play to have a medical examination.
- To avoid injury from falls and electric shocks due to spilled drinks, instruct the player not to place heavy items or drinks on the product.
- To avoid electric shocks and short circuits, do not allow customers to put hands and fingers or extraneous matter in the openings of the product or small openings in or around the doors.
- To avoid falls and resulting injury, immediately stop the customer from leaning against or climbing on the product, etc.
- To avoid electric shock and short circuit, do not allow customers to unplug the power plug without a justifiable reason.
- Instruct the guardians of small children to keep an eye on their children.

Children cannot sense danger. Allowing small children to get near a player who is playing the game could result in the children being bumped, struck or knocked down.

STOP IMPORTANT

- Players directly hold the control unit with their bare hands so it is recommended that wet towels (paper towels) be provided.
- Diligently clean the parts that players touch directly to ensure a pleasant game playing experience.
- Inspect the coin insertion slots to make sure no foreign objects have been inserted and that they have not otherwise been tampered with. This will prevent play.

⚠ CAUTION

- Immediately stop such violent acts as hitting and kicking the product. Such violent acts can cause parts damage or falling down, resulting in injury due to fragments and falling down.
- Persons other than the player should not be allowed to touch the controls during play. They may brush against or collide with the controls or the player, possibly resulting in accidents.
- Instruct those who feel sick during play to have a medical examination.
- Immediately stop users from leaning or sitting on the control panel. Such acts can lead to injury or damage to parts or the shape of the cabinet.
- Immediately stop users from swinging or reloading the control unit in a violent manner. Such acts may hurt the user or other people around them.
- Playing too close to the cabinet may cause the control unit to hit the cabinet and cause damage. Make sure that players understand to play at a safe distance from the cabinet.
- Make sure that players understand not to stand too close together when playing a 2 player game. Swinging the control unit could lead to a player getting hit and may cause injury.
- Instruct players to hold the control unit securely while playing. If the control unit is dropped, it could cause injury to the player.
- Items such as large finger rings can cause injury to the fingers while playing. Instruct players to remove all accessories that could cause an accident before playing.
- Instruct players that a single control unit is never to be held by 2 or more people during play. Otherwise there could be dangerous contact or a collision.

STOP IMPORTANT

The control units for use on 1P side (left side) and 2P side (right side) are different. Ensure that players do not confuse the right and left side control units when starting play.

3 PRECAUTIONS WHEN MOVING THE MACHINE

WARNING

- Always disconnect the power cable before moving the product. If it is moved with the power cable connected, the cable could be damaged, causing fire or electric shock.
- To move the unit over the floor, pull in the adjusters and have the casters contact the floor. While moving the unit, be careful that the casters do not roll over the power cord or the ground wire. If cord or wire is damaged, there could be electrical shocks and/or short circuits.
- When crossing a sloped or stepped area, always have the machine travel lengthways. Travelling with the machine in a sideways position could result in the machine falling over onto its side. Always use a minimum of two people working together plus lifting apparatus to accommodate sloped areas or stairs.
- To lift up the cabinet, hold it at the bottom at the designated lifting points. If you hold it anywhere else, the weight of the cabinet could cause damage to parts or attachments, resulting in injury.
- Do not push the cabinet from the side when moving. Pushing from the side may result in the cabinet falling over.
- Do not move the cabinet without the side retaining bolts fitted. Doing so may cause damage and injury.

IMPORTANT

- When moving the cabinet, do not grip or push the Reflector Plates. Doing so could deform or damage the part.
- If moving through a door or place with a low ceiling such as an elevator, you should take apart the billboard and reflector plates.

4 GAME DESCRIPTION

4-1 HOW TO PLAY

When you insert coins, they will be counted in the credit display at the bottom of the screen. When you insert enough coins for a game, the message at the bottom will change from "INSERT COIN(S)" to "PRESS START BUT- TON," and the start buttons on both sides will flash. Up to 24 credits can be counted at once. Coins inserted after 24 credits are recorded will not be counted or returned. However, the number of coins inserted will be counted in the data display and the coin meter.

NOTE: The number of credits required for a game can be set in SYSTEM TEST MODE.

Which START button you press determines which side you play on. Once you press the start button, the game be- gins.

Once the game starts, the video demonstration will play, followed by the 1 title, and then it will go to the actual game.

4-2 GAME SCREENS

This game has two modes, one is "Mission" and the other is "Wave".

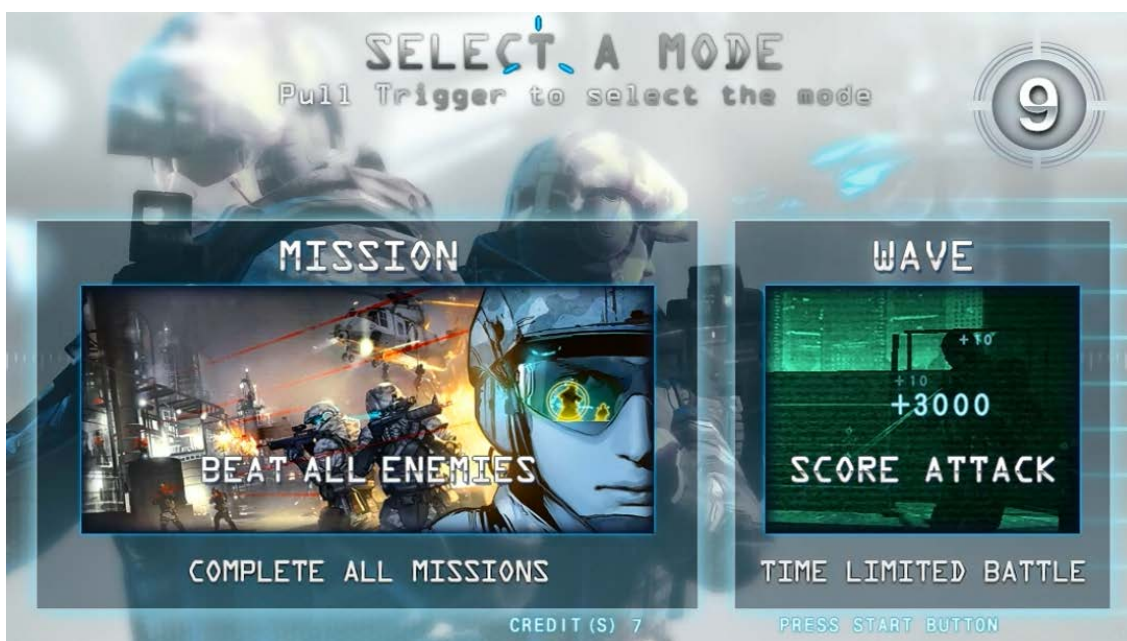

NOTE: Mode Select can be set in Game Assignments. (See 9-3-5>WAVE.)

"Mission" is the story mode. Proceed the stages with story,
When you choose the Mission mode, you can select the stages you want to play.

"WAVE" means "time Attack mode". The game was limited by time and no life system.
The game is over when setting stage numbers for a play has finished (See 8-9) to each player.

4-3 RELOADING

When the player fires all ammo remaining, the gun will be empty. The player can then reload the weapon by aiming it outside the screen. The player can reload this way even if there are still bullets left.

The gun is also reloaded automatically when the trigger is pulled with no ammo remaining. However, this type of reload takes longer than a normal reload.

The player can switch shooting mode during gameplay using the shot selector.

4-4 SWITCHING SHOOTING MODE

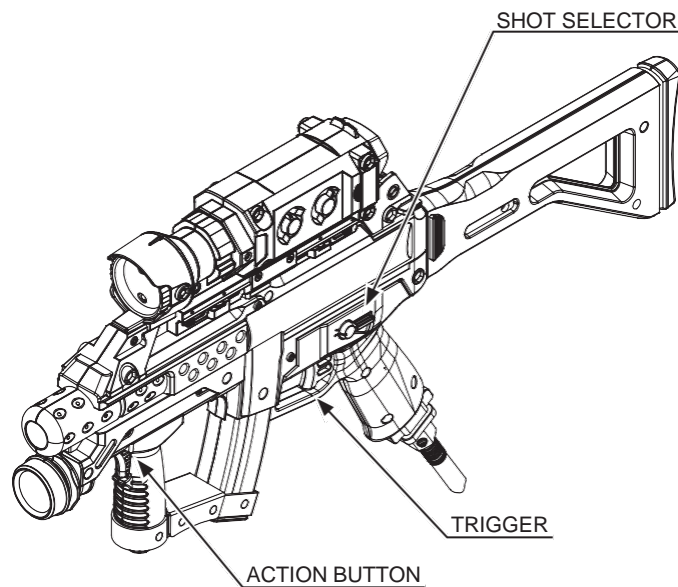

The types of shooting mode and their features are as follows.

FULL AUTO	Bullets are fired continuously as long as the trigger is held. You have limited ammunition. The number of rounds remaining is displayed to the side of the shooting mode. (See 8-2.) The number of rounds can be increased by scoring critical hits or obtaining items.
3-SHOT BURST	Pulling the trigger once fires a burst of 3 rounds in a row. You have unlimited ammunition.
SEMI AUTO	Pulling the trigger once fires 1 shot only. You have unlimited ammunition.

When shooting mode is switched, the player's crosshair is changed to the applicable shooting mode crosshair.

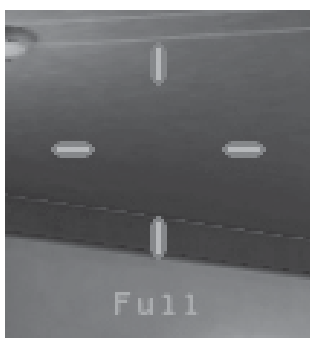

FULL AUTO CROSSHAIR

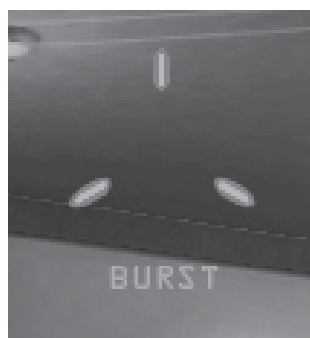

3-ROUND BURST CROSSHAIR



SEMI AUTO CROSSHAIR

4-5 STAGE SELECT

A player can select each stage (mission/wave) after mode has selected.
Player can also select new stage if player completed the stage player selected.
Game is over when the all set stages finished.

Mission



Wave

Time remaining

Ranking



4-6 ITEMS

Various items appear when the player shoots item boxes in the background. The player can then gain the effects of those items by shooting them.



ITEM BOX



LIFE RECOVERY



FULL AUTO AMMO INCREASE



4-7 EVENTS

Various events occur in the course of the game.

An explanation of the control method for the event will be displayed before the event begins.

Successfully completing events will lead to an increase in the mission success rate (the evaluation displayed after clearing the mission), and the player can earn a higher score.



EVENTS screen

4-8 BATTLES WITH BOSSES

A unique boss awaits the player at the end of each stage.

When the boss begins an attack, a cancel gauge will sometimes appear.

The boss's attack can be avoided by forcing the cancel gauge down to zero.

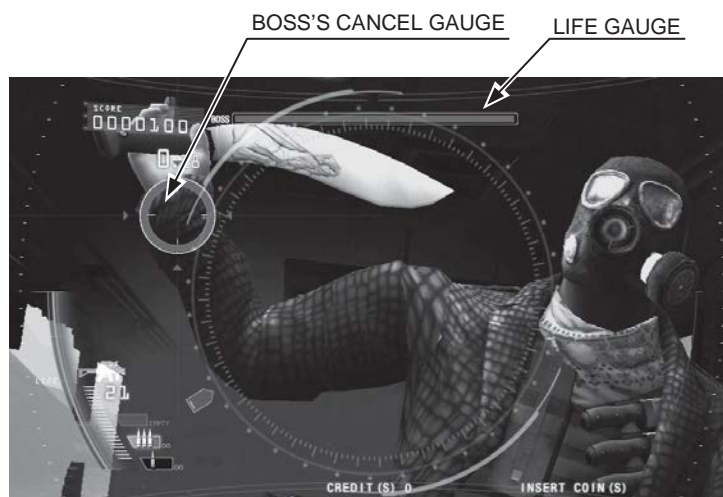

BOSS BATTLE screen 1

Shooting the boss drains the boss's LIFE gauge.
Attacking the boss's weak point drains the boss's LIFE gauge significantly.
When the boss's LIFE gauge reaches zero, the boss is defeated.

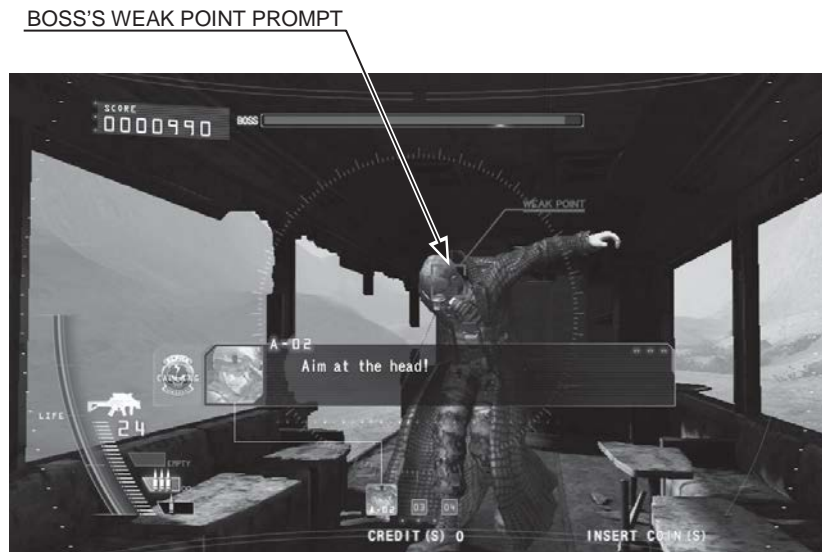

BOSS BATTLE screen 2

4-9 GAME OVER

If both players run out of LIFE, the game ends.

MISSION:

If you want to join the game during play, insert coins and press the START button at any time. If there are enough credits remaining to play, the START button on the side with no one playing flashes continuously.

When all LIFE is lost, the continue message is displayed. If you wish to continue, insert the required number of coins and press the START button again. If there are enough credits remaining to CONTINUE, you can join again by pressing the START button.

NOTE: The number of credits required to continue can be set in SYSTEM TEST MODE (See Chapter 10.)

If your total points rank among the top 50 after completing all the stages in the game, you can enter your name.

WAVE:

1. If you want to join the game during play, insert coins and press the START button at the time you can join. If there are enough credits remaining to play, the START button on the side with no one playing flashes continuously. Join the game by pressing the flashing START button.
2. When set stages are completed, the continue message is displayed. If you wish to continue, insert the required number of coins and press the START button again. If there are enough credits remaining to CONTINUE, you can join again by pressing the START button.

NOTE: The number of credits required to continue can be set in SYSTEM TEST MODE

3. If your total points rank among the top 50 after completing a stage in the game, you can enter your name.

4-10 CONTINUE PLAY BONUS

The player receives body armour as a continue play bonus when they choose to continue. Body armour will take the damage from 1 enemy attack while equipped.

NOTE: This feature can be set in GAME TEST MODE. (See 11-5.)



CONTINUE PLAY BONUS screen

CONTINUE PLAY BONUS PROMPT

5 EXPLANATION OF TEST AND DATA DISPLAY

Perform tests and data checks periodically by manipulating the TEST Button and SERVICE Button in the cabinet. Follow the instructions in this chapter to conduct checks when the game machine is first installed, when money is being collected, or when the game machine does not operate properly.

Shown overleaf are the tests and screens to be used for different problems.

WARNING

- When installing 2 or more cabinets which are networked together. The GAME SETTINGS which are adjusted within the first cabinet are reflected throughout all cabinets within that network.

IMPORTANT

- When changing the game configuration within the TEST MODE, be sure to exit all screens in the correct manner by choosing exit. DO NOT turn the machine ON/OFF to resume game. Changes WILL NOT take effect unless the correct method is used.

5-1 SWITCH UNIT AND COIN METER.

WARNING

Never touch places other than those specified. Touching places not specified can cause electric shock and short circuit accidents.

IMPORTANT

- Adjust the sound to the optimum volume, taking into consideration the environmental requirements of the installation location.
- Removing the Coin Meter circuitry renders the game inoperable.

6-1-1 SWITCH UNIT

Open the coin chute door, and the switch unit shown will appear.
The functioning of each SW is as follows:

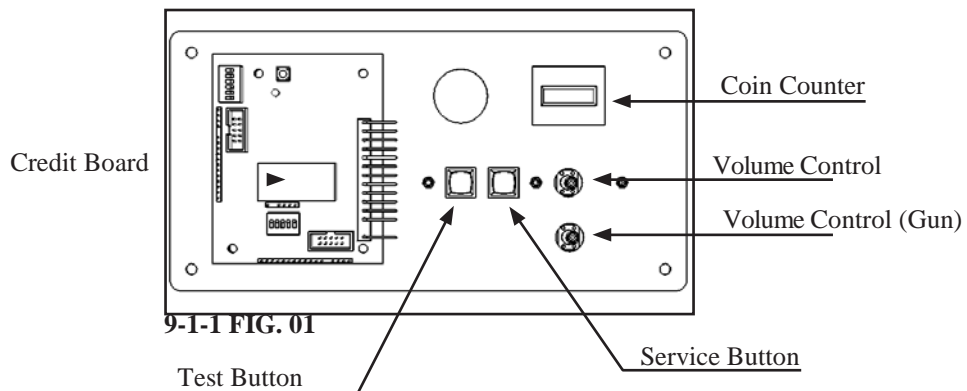

9-1-1 FIG. 01

TEST Button (TEST):	For the handling of the Test Button, refer to the following pages.
SERVICE Button (SERVICE):	Gives credits without registering on the coin meter.
Sound Volume Switch (SOUND VOLUME):	Adjust sound volume for all of the machines' speakers.
Coin Counter	Counts and displays coins in \$0.10 units.
Credit Board	Counts coins to be used a price of play

5-2 SYSTEM TEST MODE

STOP IMPORTANT

The details of changes to Test Mode settings are saved when you exit from each Test Mode by selecting EXIT. Be careful because if the power is turned off before that point, changes to the settings will be lost.

SYSTEM TEST MODE can be used to check the information or the operation of RINGWIDE, adjust Monitor color, and perform coin/credit settings.

1 Press the TEST Button after powering on the unit to display the following SYSTEM TEST MODE.

■ SYSTEM TEST MODE Screen

SYSTEM TEST MODE

GAME TEST MODE	9-3
SYSTEM INFORMATION	9-4
STORAGE INFORMATION	9-5
JVS TEST.....	9-6
MONITOR TEST.....	9-7
SPEAKER TEST.....	9-8
COIN ASSIGNMENTS	9-9
CLOCK SETTING	9-10
NETWORK SETTING	9-11
-> EXIT.....	9-12

SELECT WITH SERVICE BUTTON
AND PRESS TEST BUTTON

2 Use the SERVICE Button to move the cursor to the desired test item.

3 Press the TEST Button to enter the selected item's test.

4 After the test is complete, move the cursor to EXIT and press the TEST Button to return to the game play screen.

For a detailed explanation on the SYSTEM TEST MENU, please refer to chapter 16 - Game Board.

5-3 GAME TEST MODE

STOP IMPORTANT

- To change settings in the GAME TEST MODE, simply making changes on the setting screen will not be effective. Complete the TEST MODE in normal fashion.
- Use with the specified settings. If settings other than those specified are used, inappropriate operations or malfunction may occur.

Press the TEST Button to enter TEST MODE and bring up the SYSTEM TEST MENU screen. (See Chapter 9.) SERVICE Button to select “GAME TEST MODE,” then press the TEST Button to bring up the GAME TEST MENU screen.

5-3-1 GAME TEST MENU

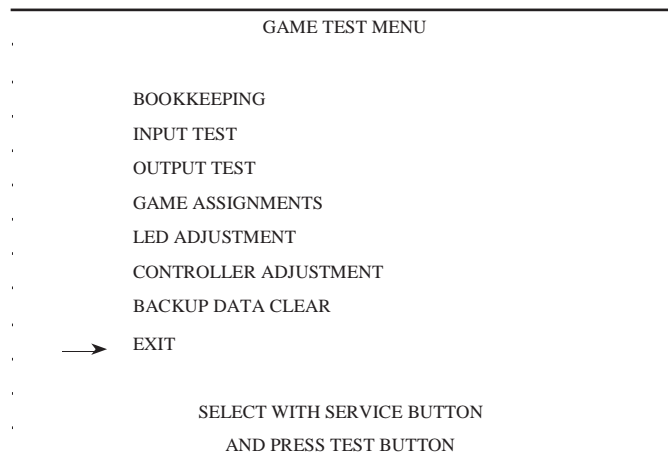

GAME TEST MENU

■ Controls

- Press the SERVICE Button to select menu item.
- Press the TEST Button to confirm the selected item.
- Selecting EXIT and pressing the TEST Button, the SYSTEM TEST MENU screen reappears.

■ Menu Items

BOOKKEEPING	Displays all recorded game data.
INPUT TEST	Test each input device used for game.
OUTPUT TEST	Test each output device used for game.
GAME ASSIGNMENTS	Adjust all game settings.
LED ADJUSTMENT	Settings for the full-color LEDs surrounding the monitor.
CONTROLLER ADJUSTMENT	Adjusts aim settings for control units.
BACKUP DATA CLEAR	Erases all types of game records.

5-3-2 BOOKKEEPING

Each game record can be viewed

BOOKKEEPING 1/3	
COIN CHUTE #1	*
COIN CHUTE #2	*
TOTAL COINS	*
COIN CREDITS	*
SERVICE CREDITS	*
TOTAL CREDITS	*
PRESS TEST BUTTON TO CONTINUE	

BOOKKEEPING SCREEN 1/3

COIN CHUTE #1	Number of coins inserted in coin chute 1.
COIN CHUTE #2	Number of coins inserted in coin chute 2.
TOTAL COINS	Total Number of coins inserted in coin chute 1 and 2.
COIN CREDITS	Number of credits for coins inserted.
SERVICE CREDITS	Number of credits entered with the SERVICE Button.
TOTAL CREDITS	Total number of all credits.

This test is used to review statistical data from the system. It consists of 3 screens of data. Page 1 displays an overview of the coins and credits data.

Press the Test Button to go to Page 2.

BOOKKEEPING 2/3	
NUMBER OF GAMES	*
NUMBER OF GAME START	*
NUMBER OF GAME JOIN	*
NUMBER OF CONTINUE	*
NUMBER OF WAVE START	*
NUMBER OF WAVE JOIN	*
NUMBER OF RETRY	*
TOTAL TIME	*D **H **M **S
PLAY TIME	*D **H **M **S
AVERAGE PLAY TIME	**M **S
LONGEST PLAY TIME	**M **S
SHORTEST PLAY TIME	**M **S

BOOKKEEPING SCREEN 2/3

NUMBER OF GAMES	Total number of games played for 1P and 2p
NUMBER OF GAME START	Total number of MISSION played from the start for 1P and 2p
NUMBER OF GAME JOIN	Total number of MISSION joined partway through for 1P and 2P.
NUMBER OF CONTINUE	Total number of MISSION continues for 1P and 2P.
NUMBER OF WAVE START	Total number of WAVE played from the start for 1P and 2p
NUMBER OF WAVE JOIN	Total number of WAVE joined partway through for 1P and 2P
NUMBER OF RETRY	Total number of WAVE continues for 1P and 2P
TOTAL TIME	The cabinet's total operating time.
PLAY TIME	Amount of time game has been played.
AVERAGE PLAY TIME	Average play time for one game.
LONGEST PLAY TIME	Longest play time for one game.
SHORTEST PLAY TIME	Shortest play time for one game.

Press the Test Button to go to Page 3.

BOOKKEEPING 3/3

0M : 00S - 0M : 29S	*
0M : 30S - 0M : 59S	*
1M : 00S - 1M : 29S	*
1M : 30S - 1M : 59S	*
2M : 00S - 2M : 29S	*
2M : 30S - 2M : 59S	*
:	
:	
9M : 00S - 9M : 29S	*
9M : 30S - 9M : 59S	*
OVER 10M : 00S	*

PRESS TEST BUTTON TO CONTINUE

BOOKKEEPING 3/3

This displays play times on a scale from 0M00S to 9M59S based on 30-second intervals.

All play times 10 minutes or over are included in the item OVER 10M00S.

The moment the START button is pressed is considered to be the start of the game, and Game Over or Continue to be the end.

(A continue is considered to be a new game. Even if the player keeps continuing and clears the game, the time from game start to finish is not taken as their play time.)

Press the Test Button to return to the Game Test Mode screen.

5-3-3 INPUT TEST

Select INPUT TEST to display the following screen and check the status of input devices.

This test should be used periodically to check that each input device is functioning correctly.

INPUT TEST		
PLAYER	1	2
TRIGGER	OFF	OFF
ACTION	OFF	OFF
CHANGE	OFF	OFF
SIGHT-X	**	**
SIGHT-Y	**	**
SCREEN	OUT	OUT
START	OFF	OFF
SERVICE	OFF	
TEST	OFF	

SELECT WITH SERVICE
AND PRESS TEST BUTTON

INPUT TEST screen

■ Controls

- The SCREEN setting is normal if it changes from OUT to IN when the control units are pointed at the screen.
- Input devices are working correctly if the corresponding menu item switches from OFF to ON when the device is operated.
- Press the TEST Button and the SERVICE Button simultaneously to return to GAME TEST MENU screen.

■ Menu Items

TRIGGER	This will say ON when the triggers on the control units are being pulled and OFF when they are released.
ACTION	This will say ON when the action buttons on the control units are being pulled and OFF when they are released.
CHANGE	This will say ON when the shot selectors on the control units are being pulled and OFF when they are released.
SIGHT-X	This shows the aim location for the X direction on the control units.
SIGHT-Y	This shows the aim location for the Y direction on the control units.
SCREEN	This will say IN when the control units are aimed inside the screen and OUT when they are aimed outside the screen.
START	This will say ON when the START buttons are being pressed and OFF when they are released.
SERVICE	This will say ON when the SERVICE button is being pressed and OFF when it is released.
TEST	This will say ON when the TEST button is being pressed and OFF when it is released.

5-3-4 OUTPUT TEST

This screen is for confirming the proper operation of each output device used by the game. Periodically use this screen to check the status of each output device.

OUTPUT TEST	
1P START LAMP	OFF
1P RECOIL	OFF
1P HOLDER LAMP	OFF
2P START LAMP	OFF
2P RECOIL	OFF
2P HOLDER LAMP	OFF
BILLBOARD	
EXIT	
SELECT WITH SERVICE AND PRESS TEST BUTTON	

OUTPUT TEST screen

■Controls

- Press the SERVICE Button to select menu item.
- When the TEST Button is being pressed, the selected item will change from OFF to ON and the corresponding output device will operate.
- When the TEST Button is released, the selected item will change from ON to OFF and the corresponding output device will cease operation.
- Select EXIT and press the TEST Button to return to the GAME TEST MENU screen.

■Menu Items

1P/2P START LAMP	1P/2P START Button lamp
1P/2P RECOIL	Activates the solenoid in 1P/2P control unit. Reverts to OFF after one activation.
1P/2P HOLDER LAMP	1P/2P controller holder lamp
BILLBOARD	Lamp of the billboard above the monitor.

5-3-5 GAME ASSIGNMENTS

Adjust all game settings.

GAME ASSIGNMENTS	
LANGUAGE	ENGLISH
DIFFICULTY	NORMAL
LIFE	4
REACTION	ON
ADVERTISE SOUND	ON
DAMAGE EFFECT	ON
MISSION STAGES	3
WAVE STAGES	3
PENALTY	100%
CONTINUE COUNT	NORMAL
DRESS CODE	OFF
SWIPE CARD TO PLAY	OFF
EXIT	

GAME ASSIGNMENTS screen

■ Controls

- Press the SERVICE Button to select menu item.
- Press the TEST Button to change the value of the selected item.
- Select EXIT and press the TEST Button to return to the GAME TEST MENU screen.

■ Menu Items

LANGUAGE	Sets the Language. (Default setting: ENGLISH) There are 5 Languages: ENGLISH,SPANISH,PORTUGUESE,TURKISH,RUSSIAN
DIFFICULTY	Sets the level of difficulty.(Default setting: NORMAL) There are 5 levels: VERY EASY, EASY, NORMAL, HARD, VERY HARD.
LIFE	The number of LIFE(s) the player will start the game with. (Default setting:3) Can be set between 2 and 7.
REACTION	ON = Gun will recoil OFF = Gun will not recoil
ADVERTISE SOUND	Turns sound ON/OFF in advertise mode. (Default: ON)
DAMAGE EFFECT	There are 5 levels : ON, 7/10, 5/10, 3/10, OFF.
MISSION STAGES	Sets the stage numbers for completing the MISSION (Default setting: 3) There are 3 levels: 3, 4 and 5(full stages)
WAVE STAGES	Sets the stage numbers for WAVE per a game (Default setting: 3) There are 5 levels: OFF, 2, 3, 4, 5. OFF will cut the sequence of mode select and Players can only play MISSION mode.
ARMOR	ON = Body armor will be provided when player continues. OFF = Body armor will not be provides
PENALTY	Set the amount of friendly fire penalty (Default setting: 100%) There are 3 levels: OFF, 50%, 100%. OFF means no penalty for players.
CONTINUE COUNT	SET Continue count speed. (Default setting: NORMAL) There are 3 levels: SHORT, NORMAL and Long
DRESS CODE	Enables the payer to choose player uniform – Default = OFF
SWIPE CARD TO PLAY	Enables the Swipe Card Mode - Default = OFF

5-3-6 LED ADJUSTMENT

Conduct adjustment of the full-color LEDs surrounding the monitor.

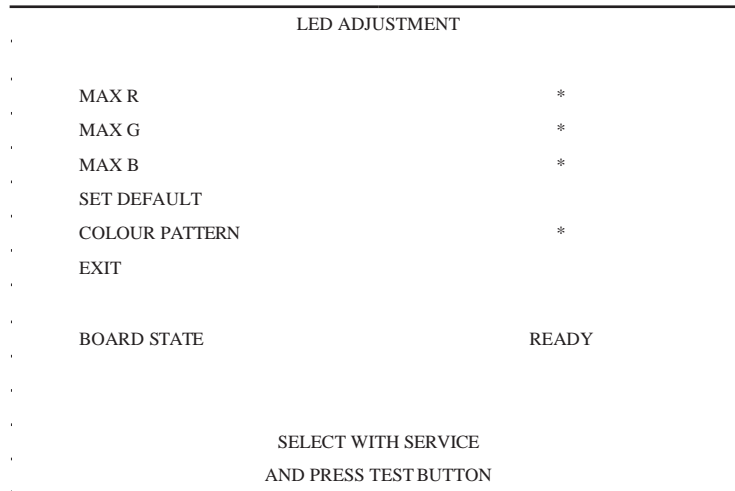

LED ADJUSTMENT screen

■ Controls

- Press the SERVICE Button to select menu item.
- Press the TEST Button to change the value of the selected item.
- Select EXIT and press the TEST Button to return to the GAME TEST MENU screen.

■ Menu Items

MAX R	Adjusts the brightness of red LEDs from 0.1 to 1.0 in gradients of 0.1. (Default setting: 1.0)	
MAX G	Adjusts the brightness of green LEDs from 0.1 to 1.0 in gradients of 0.1. (Default setting: 0.9)	
MAX B	Adjusts the brightness of blue LEDs from 0.1 to 1.0 in gradients of 0.1. (Default setting: 0.7)	
SET DEFAULT	Returns the LED color shades to their defaults.	
COLOR PATTERN	Switches the LED display color pattern: WHITE; BLUE; RED; GREEN; BLACK TO WHITE.	
BOARD STATE	Displays status of LED board.	
	READY	Usable status
	NOT READY	Undergoing formatting status
	N O L E D BOARD	Unusable status

5-3-7 CONTROLLER ADJUSTMENT

This screen allows for the adjustment of the control unit's crosshair settings which are used during gameplay.

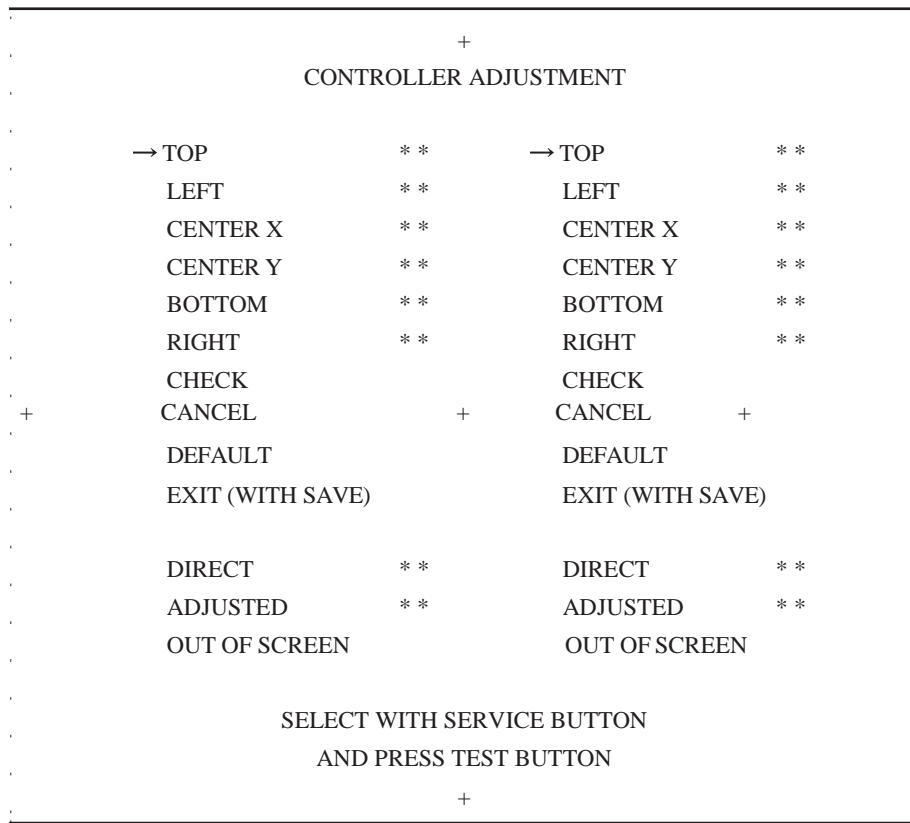

CONTROLLER ADJUSTMENT screen

■Controls

- Press the SERVICE Button or START Button to select menu item.
- Select EXIT (WITH SAVE) and press the TEST Button to save the values you have set and return to the GAME TEST MENU screen.

■Menu Items

TOP*	Sets the crosshair value for the upper limit of the Y axis. Aim at the + mark at the top of the screen and pull the trigger to confirm setting.
LEFT*	Sets the crosshair value for the left limit of the X axis. Aim at the + mark at the left of the screen and pull the trigger to confirm setting.
CENTER X*	Sets the crosshair value for the center of the X axis. Aim at the + mark in the center of the screen and pull the trigger to confirm setting.
CENTER Y*	Sets the crosshair value for the center of the Y axis. Aim at the + mark in the center of the screen and pull the trigger to confirm setting.
BOTTOM*	Sets the crosshair value for the lower limit of the Y axis. Aim at the + mark at the bottom of the screen and pull the trigger to confirm setting.
RIGHT*	Sets the crosshair value for the right limit of the X axis. Aim at the + mark at the right of the screen and pull the trigger to confirm setting.
CHECK	Displays the newly adjusted crosshair settings on-screen.
CANCEL	Returns the newly adjusted crosshair settings to the previous settings.
DEFAULT	Set the values for the control units to default.

*Values on the left are the previous settings, and values on the right are the new settings.

5-3-8 BACKUP DATA CLEAR

Delete various game data.

BACKUP DATA CLEAR

YES (CLEAR)
→ NO (CANCEL)

SELECT WITH SERVICE BUTTON
AND PRESS TEST BUTTON

BACKUP DATA CLEAR screen (1/2)

BACKUP DATA CLEAR

COMPLETED

PRESS TEST BUTTON TO EXIT

BACKUP DATA CLEAR screen (2/2)

■ Controls

- Press the SERVICE Button to select menu item.
- Selecting YES (CLEAR) and pressing the TEST Button will clear all data, and “COMPLETED” will be displayed. At this point, press the TEST Button to return to the GAME TEST MENU screen.

5-4 SYSTEM INFORMATION

The SYSTEM INFORMATION screen displays system information.

The following information is displayed on this screen.

SYSTEM INFORMATION 1/2

The SYSTEM INFORMATION 1/2 screen displays system information.

■ SYSTEM INFORMATION 1/2 Screen

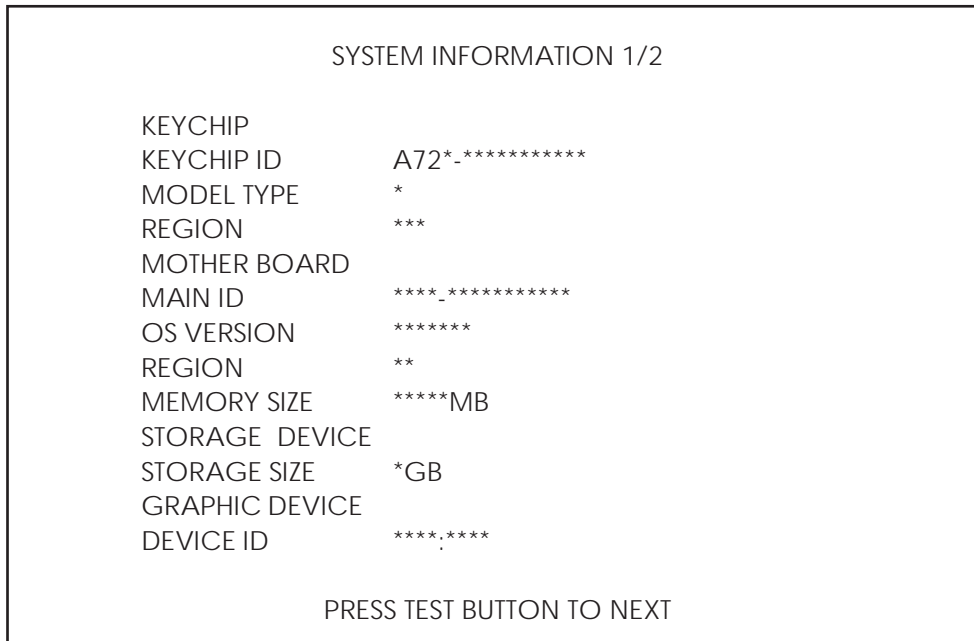

The following information is displayed on this screen.

● KEYCHIP

KEYCHIP ID	The serial number of the key chip.
MODEL TYPE	The model type.
REGION	The region setting of the key chip.

● MOTHER BOARD

MAIN ID	The serial number of the game board.
OS VERSION	The system's OS version.
REGION	The region setting of the game board.
MEMORY SIZE	The onboard memory size.

● STORAGE DEVICE

STORAGE SIZE	The total capacity of the program installer device.
--------------	---

● GRAPHIC DEVICE

DEVICE ID	The graphic device's ID.
-----------	--------------------------

Press the TEST Button to move to the SYSTEM INFORMATION 2/2.

SYSTEM INFORMATION 2/2

The SYSTEM INFORMATION 2/2 screen displays system information.

Press the TEST Button on the SYSTEM INFORMATION 2/2 screen to return to the SYSTEM TEST MODE screen.

■ SYSTEM INFORMATION 2/2 Screen

SYSTEM INFORMATION 2/2	
VOLTAGE CPU CORE	+*. **[V]
VOLTAGE 3.3V	+*. **[V]
VOLTAGE 5V	+**.[**[V]
VOLTAGE 12V	+*. **[V]
VOLTAGE BATTERY	*****
FAN CPU	****[rpm]
FAN CHASSIS	****[rpm]
TEMP CPU	**[C]
TEMP CHASSIS	**[C]
PRESS TEST BUTTON TO EXIT	

The following information is displayed on this screen.

VOLTAGE CPU CORE	CPU core voltage
VOLTAGE 3.3V	3.3 V voltage
VOLTAGE 5V	5 V voltage
VOLTAGE 12V	12 V voltage
VOLTAGE BATTERY	Backup battery status
FAN CPU	CPU fan RPM
FAN CHASSIS	Case fan RPM
TEMP CPU	CPU temperature
TEMP CHASSIS	Case temperature

Press the TEST Button to return to the SYSTEM TEST MODE screen.

5-5 STORAGE INFORMATION

The STORAGE INFORMATION screen displays information on the game stored in the program installer device. This screen is also used when uninstalling the game stored within the program installer device.

Until preparations to launch the game are complete, a now checking screen will be displayed and uninstall cannot be performed.

If the program installer device does not contain any game data, "GAME PROGRAM NOT READY" screen will be displayed and uninstall cannot be performed.

NOTE: If an uninstall is performed, an install will then have to be performed before the game board can be used again. Do not needless perform an uninstall.

■ STORAGE INFORMATION Screen

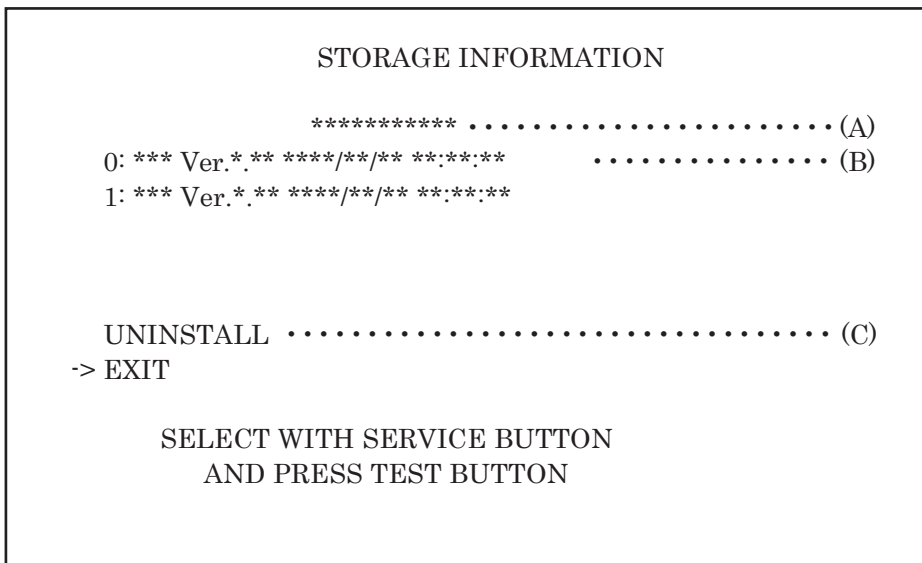

The following information is displayed on this screen.

(A) GAME TITLE

(B) INSTALLED GAME PROGRAM LIST

- GAME ID
- VERSION
- DATE & TIME OF RELEASE

(C) UNINSTALL

When preparations to launch the game are complete, it is possible to uninstall the game stored in the program installer device. Select UNINSTALL and then select "YES" to uninstall all game programs stored in the program installer device. Performing this operation will also mean that GAME TEST MODE will disappear from the SYSTEM TEST MODE screen.

Move the cursor to EXIT and press the TEST Button to return to the SYSTEM TEST MODE screen.

5-6 JVS TEST

The JVS TEST screen displays information on the connected JVS I/O boards. Select INPUT TEST to display input data for the currently displayed JVS I/O board. Select NODE to display information on the next NODE. If no JVS I/O boards are connected, the message “NO JVS NODE” will be displayed.

■ JVS TEST Screen

```

                                JVS TEST
INPUT TEST
-> NODE          1/*
  EXIT
  NAME          SEGA ENTERPRISES.LTD.:
                I/O BD JVS :837-13551:
                Ver1.00
                CMD VER  2.0
                COM VER  1.0
                SWITCH   13 BIT[S]
                COIN     2 PLAYER(S)
                ROTARY   8 SLOT(S)
                ANALOG   0 CH
                KEYCODE  0
                SCREEN   X:0 Y:0 CH:0
                GENERAL IN
                CARD     0 SLOT(S)
                HOPPER OUT 0 CH
                DRIVER OUT 6 CH
                ANALOG OUT 0 CH
                CHARACTER LINE:0
                CHARA:0
                0
                                SELECT WITH SERVICE BUTTON
                                AND PRESS TEST BUTTON

```

NOTE: The screen display will vary depending on the I/O board that is connected.

The figure above is one example.

NODE	The currently displayed JVS I/O board number and the total number of connected JVS I/O boards
NAME	Name of the connected I/O board, etc.
CMD VER	Command format version
JVS VER	JVS standard version
COM VER	Communication version
SWITCH	Number of players and number of 1P switches
COIN	Number of coin slots
ANALOG	Number of analog channels
ROTARY	Number of rotary encoders
KEYCODE	Keycode input active/inactive
SCREEN	Screen position input (X axis, Y axis, number of channels)
GENERAL IN	Number of standard switches
CARD	Number of card slots
HOPPER OUT	Number of hoppers
DRIVER OUT	Number of standard output drivers
ANALOG OUT	Number of analog output channels
CHARACTER	Number of characters/lines displayed
BACKUP	Backup present/absent

Move the cursor to EXIT and press the TEST Button to return to the SYSTEM TEST MODE screen.

JVS INPUT TEST

Use the JVS INPUT TEST to test the JVS input.

The hexadecimal input information from the JVS I/O board will be displayed in real time.

■ JVS INPUT TEST Screen

JVS TEST INPUT TEST					
NODE	1/*				
SYSTEM		00	ROTARY	0	0000
PLAYER	1	0000	ROTARY	1	0000
PLAYER	2	0000	ROTARY	2	0000
COIN 1	0000	ROTARY	3	0000	
COIN 2	0000	ROTARY	4	0000	
ANALOG	0	0000	ROTARY	5	0000
ANALOG	1	0000	ROTARY	6	0000
ANALOG	2	0000	ROTARY	7	0000
ANALOG	3	0000			
ANALOG	4	0000			
ANALOG	5	0000			
ANALOG	6	0000			
ANALOG	7	0000			

PRESS TEST BUTTON AND
SERVICE BUTTON TO EXIT

NOTE: The screen display will vary depending on the I/O board that is connected.

The figure above is one example.

The following information is displayed on this screen.

SYSTEM	System switch input data
PLAYER	Player number and player switch input data
COIN	Slot number and coin input data
ANALOG	Channel number and analog input data
ROTARY	Rotary number and rotary input data

Press the SERVICE and TEST Buttons simultaneously to return to the JVS TEST screen.

6-8 SPEAKER TEST

Use SPEAKER TEST to check the output of each speaker by having them each emit a test sound.

Select each speaker with the cursor and press the TEST Button to turn that speaker ON or OFF.

When set to ON a test sound will be emitted from that speaker.

It is possible to set multiple speakers to emit the test sound at the same time.

Depending on the cabinet used, some items will be displayed but no sound will be emitted.

■ SPEAKER TEST Screen

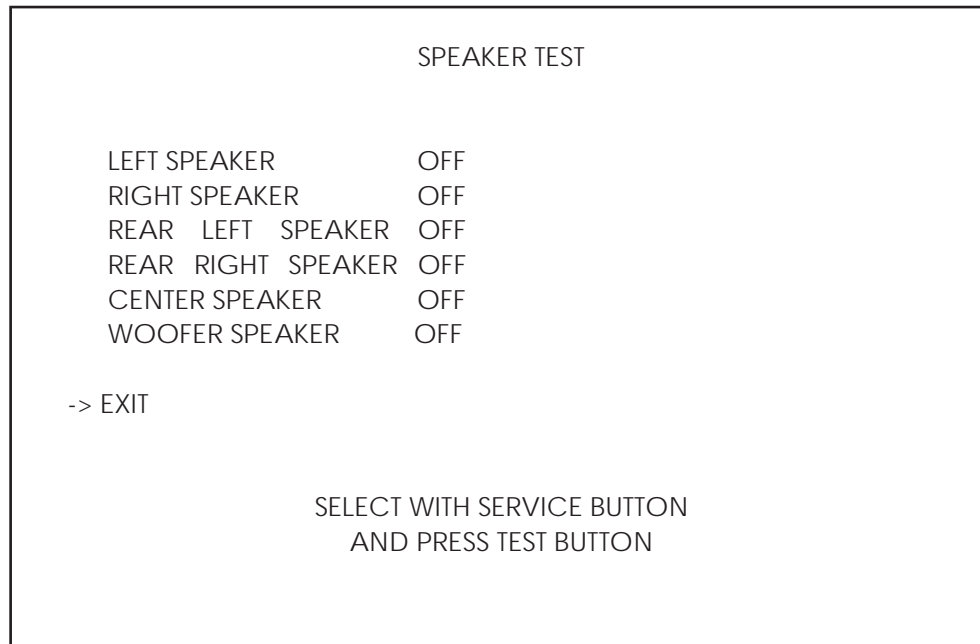

Move the cursor to EXIT and press the TEST Button to return to the SYSTEM TEST MODE screen.

5-9 COIN ASSIGNMENTS

Use COIN ASSIGNMENTS to alter the credit settings.
 The game will award players the number of credits determined here.
 Settings will only be saved if they have been changed.

■ COIN ASSIGNMENTS Screen

COIN ASSIGNMENTS

COIN CHUTE TYPE COMMON (A)

SERVICE TYPE COMMON (B)

COIN CHUTE #1 COIN TO CREDIT RATE (C-1)

1 COIN(S) COUNT AS 1 CREDIT(S)

COIN CHUTE #2 COIN TO CREDIT RATE (C-2)

1 COIN(S) COUNT AS 1 CREDIT(S)

DETAIL SETTING (D)

GAME COST SETTING (H)

-> EXIT (I)

SELECT WITH SERVICE BUTTON
 AND PRESS TEST BUTTON

[COIN CHUTE TYPE: COMMON]

The following information is displayed on this screen.

(A) COIN CHUTE TYPE

COMMON	Allow all credits to be used by all players.
INDIVIDUAL	Treat each player's credits individually.

(B) SERVICE TYPE (Service Button Type)

COMMON	When the COIN CHUTE TYPE is set to COMMON, the number of credits available to all players will increase by 1.
	When the COIN CHUTE TYPE is set to INDIVIDUAL, each player's credits will increase by 1.
INDIVIDUAL	When the COIN CHUTE TYPE is set to COMMON, the number of credits available to all players will increase by 1.
	When the COIN CHUTE TYPE is set to INDIVIDUAL, the player corresponding to the SERVICE Button's credits will increase by 1.

(C-1) COIN CHUTE #1 COIN TO CREDIT RATE (Coin and credit conversion rate 1)

1 COIN(S) COUNT AS 1 CREDIT(S)	1 coin counts as 1 credit
2 COIN(S) COUNT AS 1 CREDIT(S)	2 coins count as 1 credit
3 COIN(S) COUNT AS 1 CREDIT(S)	3 coins count as 1 credit
4 COIN(S) COUNT AS 1 CREDIT(S)	4 coins count as 1 credit
5 COIN(S) COUNT AS 1 CREDIT(S)	5 coins count as 1 credit
1 COIN(S) COUNT AS 2 CREDIT(S)	1 coin counts as 2 credits
1 COIN(S) COUNT AS 3 CREDIT(S)	1 coin counts as 3 credits
1 COIN(S) COUNT AS 4 CREDIT(S)	1 coin counts as 4 credits
1 COIN(S) COUNT AS 5 CREDIT(S)	1 coin counts as 5 credits
FREE PLAY	Free play (no coins required)
DETAIL SETTING	More detailed settings

(C-2) COIN CHUTE #2 COIN TO CREDIT RATE (Coin and credit conversion rate 2)

When (A) COIN CHUTE TYPE is set to “COMMON,” the detail settings for this item are restricted to the settings listed in (C-1).

(D) DETAIL SETTING

The COIN ASSIGNMENTS DETAIL SETTING screen allows more detailed settings that cannot be performed on (C) the COIN TO CREDIT RATE screen to be performed.

■ **DETAIL SETTING Screen**

COIN ASSIGNMENTS
DETAIL SETTING

COIN CHUTE #1 MULTIPLIER E-1
 1 COIN COUNT AS 1 COIN (S)
 COIN CHUTE #2 MULTIPLIER E-2
 1 COIN COUNT AS 1 COIN (S)
 BONUS ADDER NO BONUS ADDER F
 COIN TO CREDIT 1 COIN (S) 1 CREDIT G
 -> EXIT

COIN CHUTE #1 OPERATION

COIN	1	2	3	4	5	6	7	8	9
CREDIT	1	2	3	4	5	6	7	8	9

COIN CHUTE #2 OPERATION

COIN	1	2	3	4	5	6	7	8	9
CREDIT	1	2	3	4	5	6	7	8	9

SELECT WITH SERVICE BUTTON
AND PRESS TEST BUTTON

[COIN CHUTE TYPE: COMMON]

The following information is displayed on this screen.

(E-1) COIN CHUTE #1 MULTIPLIER

Coin conversion rate for #1. (How many coins 1 inserted coin counts for)

(E-2) COIN CHUTE #2 MULTIPLIER

Coin conversion rate for #2. (How many coins 1 inserted coin counts for)

NOTE: When (A) COIN CHUTE TYPE is set to "COMMON," COIN CHUTE #1 and COIN CHUTE #2 can be set separately.

(F) BONUS ADDER

Use of a bonus coin.

NO BONUS ADDER	No bonus coin given
2 COINS GIVE 1 EXTRA COIN	2 coins inserted successively award 1 bonus coin
3 COINS GIVE 1 EXTRA COIN	3 coins inserted successively award 1 bonus coin
4 COINS GIVE 1 EXTRA COIN	4 coins inserted successively award 1 bonus coin
5 COINS GIVE 1 EXTRA COIN	5 coins inserted successively award 1 bonus coin
6 COINS GIVE 1 EXTRA COIN	6 coins inserted successively award 1 bonus coin
7 COINS GIVE 1 EXTRA COIN	7 coins inserted successively award 1 bonus coin
8 COINS GIVE 1 EXTRA COIN	8 coins inserted successively award 1 bonus coin
9 COINS GIVE 1 EXTRA COIN	9 coins inserted successively award 1 bonus coin

(G) COIN TO CREDIT

The number of coins to number of credits conversion rate.

Move the cursor to EXIT and press the TEST Button to return to the COIN ASSIGNMENTS screen.

(H) GAME COST SETTING

Use the COIN ASSIGNMENTS GAME COST SETTING screen to set the cost (number of required credits) that the game program will use to determine if there are enough credits to play the game.

A total of 8 game costs can be defined. The game cost is defined by the BOOT ID, and when the second boot recognizes the game, the game cost defined by the BOOT ID will be displayed.

If the game is not recognized, the default game cost will be displayed.

■ GAME COST SETTING Screen

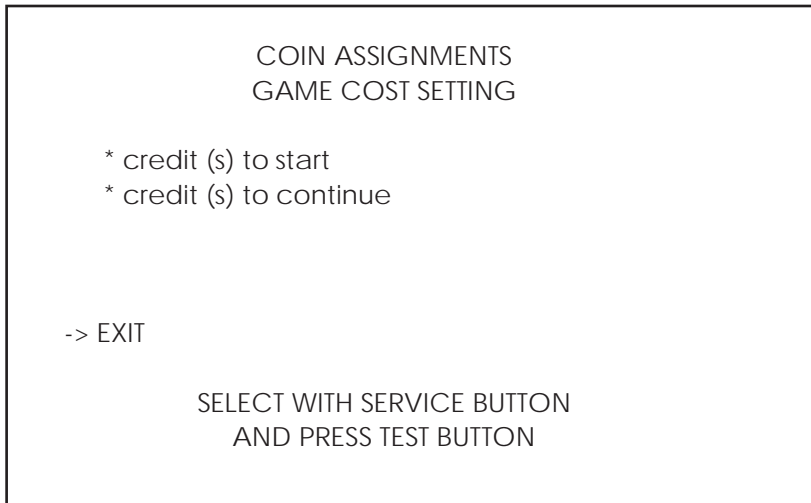

NOTE: The screen display will vary depending on the game that is installed. The figure above is one example.

Move the cursor to EXIT and press the TEST Button to return to the COIN ASSIGNMENTS screen.

(I) EXIT

Move the cursor to EXIT and press the TEST Button to return to the SYSTEM TEST MODE screen.

5-10 CLOCK SETTINGS

Use CLOCK SETTING to set the date and time.

Use the SERVICE Button to move the cursor to the category that you wish to change and press the TEST Button to increase that value. Holding the TEST Button down will make the value continuously increase.

■ CLOCK SETTING Screen

CLOCK SETTING

CLOCK
20**/ */ * (THU) 12:00:00 A

TIMEZONE UTC+09:00 B

DAYLIGHT SAVING TIME(DST) DISABLE C

-> EXIT

SELECT WITH SERVICE BUTTON
AND PRESS TEST BUTTON

[DAYLIGHT SAVING TIME (DST): DISABLE]

(A) CLOCK

Displays the current time and date.

The time and date can be changed by selecting CLOCK.

Use the SERVICE Button to move the underline to the item you want to change and press the TEST Button to change the value.

If you select EXIT and press the TEST Button after changing the setting, you will be asked whether you really want to make the changes.

Select "YES" to change the value or "NO" to leave it as it is, and press the TEST Button.

Games connected to the network will adjust the time automatically.

Exercise caution as the game may become unplayable if the time is changed.

(B) TIMEZONE

Displays the time zone setting. If the machine is not available for ALL.Net, it is not displayed.

```
CLOCK SETTING

CLOCK
20**/ */ *(TUE) 12:00:00

TIMEZONE                UTC+09:00
DAYLIGHT SAVING TIME(DST) ..... ENABLE

DST START
MAR/2nd/SUN 02:00:00
DST END
NOV/1st/SUN 02:00:00

-> EXIT

SELECT WITH SERVICE BUTTON
AND PRESS TEST BUTTON
```

[DAYLIGHT SAVING TIME (DST): ENABLE]

(C) DAYLIGHT SAVING TIME (DST)

Displays the daylight saving time setting.

If set to ENABLE, you can specify when to start and end daylight saving time.

Move the cursor to EXIT and press the TEST Button to return to the SYSTEM TEST MODE screen.

5-11 NETWORK TEST

Use NETWORK SETTING to determine network settings or to test the network.

There is no need to alter these settings for a game that does not use a network.

■ NETWORK SETTING (Setting Menu) Screen

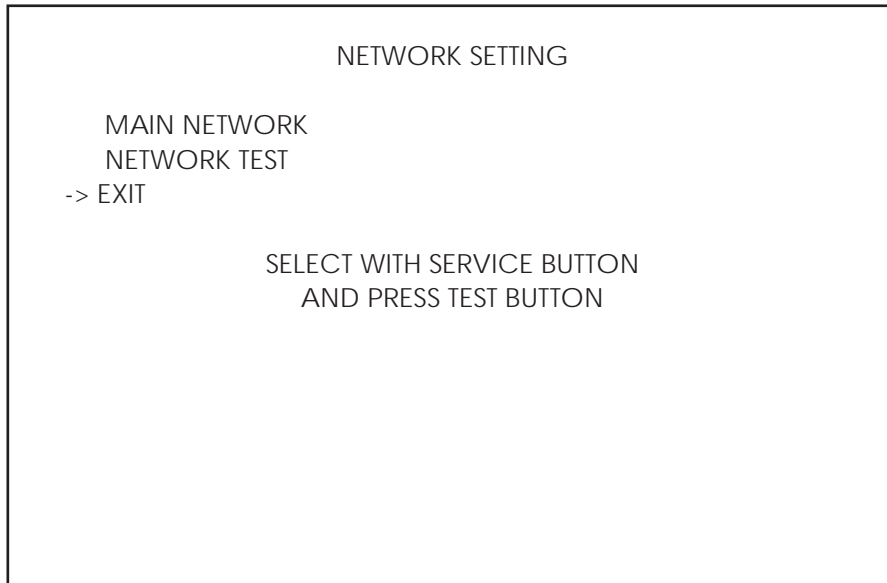

The following information is displayed on this screen.

MAIN NETWORK	Performs a network setting.
NETWORK TEST	Performs a network test.

Move the cursor to EXIT and press the TEST Button to return to the SYSTEM TEST MODE screen.

When using a hub for connecting a number of cabinets in a network, please change the IP addresses accordingly.

IP (192.168.88.XX) XX indicating the cabinet number. i.e. 192.168.88.**01** for cabinet 1. 192.168.88.**02** for cabinet 2 and so on up to a total of 8 cabinets.

STOP IMPORTANT

- Do not connect any other device into the same hub as the linked cabinet. Doing so will cause networking problems between cabinets

MAIN NETWORK

Select MAIN NETWORK on the NETWORK SETTING (Setting Menu) and the following screen will be displayed.

■ NETWORK SETTING (Network Setting) Screen

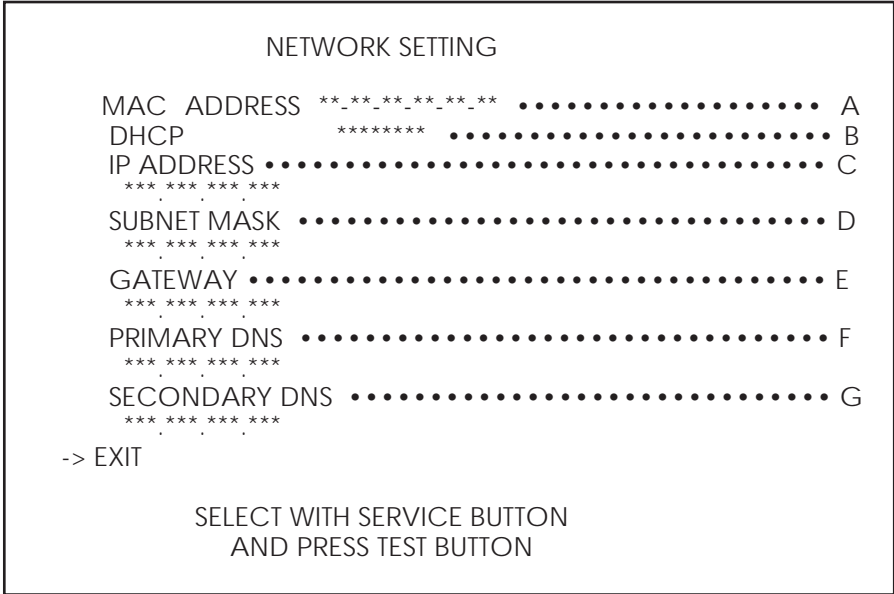

The following information is displayed on this screen.

(A) MAC ADDRESS

The individual ID number assigned to each device using the Ethernet.

(B) DHCP

Set automatic acquisition of network settings.

ENABLE: Acquire network settings automatically. (use when connected to a router)

DISABLE: Input network settings manually. (use when connected to a Hub and/or fixed IP address)

(C) IP ADDRESS

A setting required for the network.

After setting the numbers, select SET and press the TEST Button to save the setting.

When DHCP is set to ENABLE, this item cannot be selected.

(D) SUBNET MASK

A setting required for the network.

After setting the numbers, select SET and press the TEST Button to save the setting.

When DHCP is set to ENABLE, this item cannot be selected.

(E) GATEWAY

A setting required for the network. See the manual supplied with each game software for the correct setting.

After setting the numbers, select SET and press the TEST Button to save the setting.

When DHCP is set to ENABLE, this item cannot be selected.

(F) PRIMARY DNS

A setting required for the network. See the manual supplied with each game software for the correct setting.

After setting the numbers, select SET and press the TEST Button to save the setting.

When DHCP is set to ENABLE, this item cannot be selected.

(G) SECONDARY DNS

A setting required for the network. See the manual supplied with each game software for the correct setting.

After setting the numbers, select SET and press the TEST Button to save the setting.

When DHCP is set to ENABLE, this item cannot be selected.

Move the cursor to EXIT and press the TEST Button to return to the NETWORK SETTING (Setting Menu) screen.

NETWORK TEST

Check the network connection.

The test will begin as soon as this screen is displayed. The machine cannot be operated until the test is finished.

■ NETWORK TEST Screen

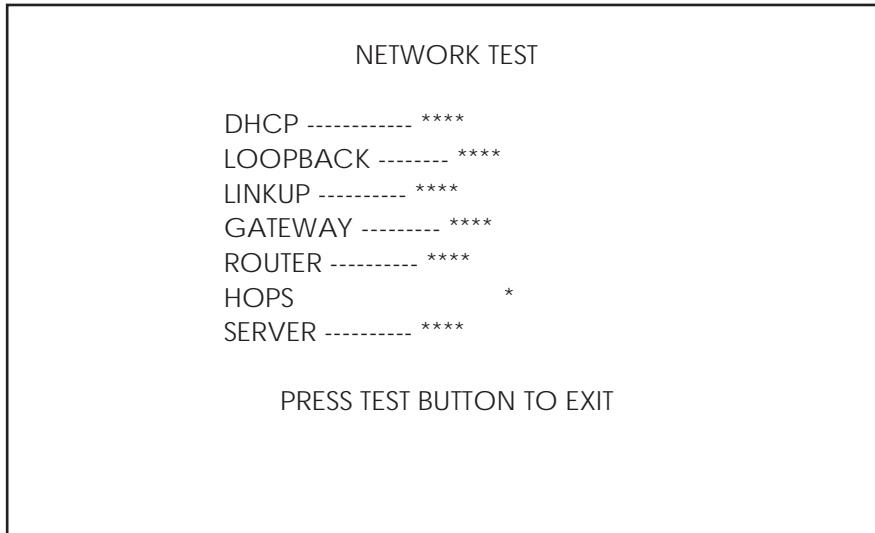

The following information is displayed on this screen.

DHCP	Status of communication settings acquisition when DHCP is set to ENABLE.
LOOPBACK	RINGWIDE network function operation status.
LINKUP	LAN cable connection status.
GATEWAY	Status of connection with title router, etc.
ROUTER	Status of connection with ALL.Net router.
HOPS	Number of router connections to ALL.Net router.
SERVER	Status of connection with ALL.Net server.

The status of determining items is as listed in the table below:

CHECK	Indicates that the item is currently being checked.
GOOD	Indicates that the item is functioning normally.
BAD	Indicates that the item is not functioning normally. (Damaged, incorrect settings, etc.)
N/A	Indicates that the item has not been checked. (Prerequisites have not been met, etc.)

Press the TEST Button to return to the NETWORK SETTING (Setting Menu) screen.

5-12 EXIT

Exit the Test Mode.

6 CONTROLLER UNIT(S)

WARNING

- Before starting to work, be sure to turn the power off. Working without turning the power off can cause an electric shock or short circuit.
- Be careful not to damage the cables. Damaged cables may cause electric shock or short circuit or present a risk of fire.
- Exercise due caution in performing soldering procedures. If soldering iron is handled carelessly, there could be fires or burns.

CAUTION

- When fastening plastic parts, be careful not to tighten screws and nuts excessively. Failure to observe this may damage the parts and cause injury due to fragments resulting from damage.
- After the unit has been disassembled and reassembled again, check carefully to be sure that there are no gaps or rattling at the junctions and that the trigger can be operated smoothly. If there are gaps or rattling, or if operation is not satisfactory, the players could get fingers or hands caught, resulting in injury.
- Be sure to inspect control unit surfaces for cracks and damage. Players could be injured if they play when the unit is cracked or damaged.
- Assemble so that there is no gap between the L and R covers. If there is a gap or rattling, the players could get fingers or hands caught, resulting in injury.

IMPORTANT

- Do not cut the tie that holds the cables together inside the control unit. Doing so can lead to connection failures with the connectors inside the unit. If the tie must be cut to replace cables or perform other such work, make sure that they are returned to the original position and tied together again.
- Once the product has been disassembled, use slack preventive agent (product No.: 090-0012). Coat screws with suitable amounts of this agent and then tighten them. If this agent is not used, the product might start rattling or come apart.
- Use the slack preventive agent prescribed in these instructions. If any other agent is used, there could be chemical changes that inhibit the use of screws and part surfaces could be damaged.
- Be careful not to damage or lose small parts or screws.
- When a part has been replaced, be sure to always make adjustments and check conditions in TEST MODE.

6-1 REMOVING THE CONTROLLER SUPPORT

1 Refer to 10-1 "REMOVING THE CONTROL UNIT" and take off the control unit.

2 Using an Allen wrench, remove the 6 hexagon socket head screws, and take off the 4 controller supports.

NOTE: When reattaching reinforcement parts, always refer to the figure to ensure that screws are not put into the wrong places. Also, regularly check that the screws have not loosened over time.

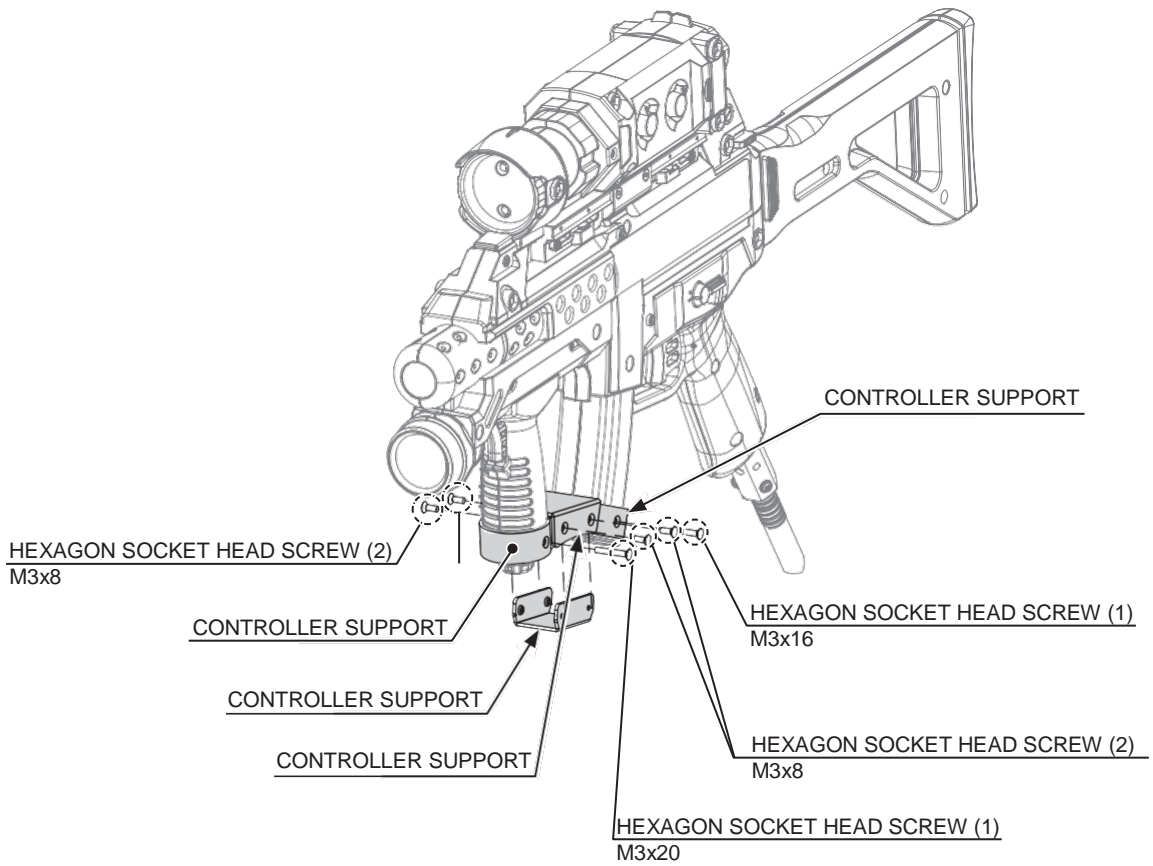

6-2 REMOVING THE SCOPE

1 Refer to 10-1 "REMOVING THE CONTROL UNIT" and take off the control unit.

2 Remove the 2 screws and take off the lens cap.

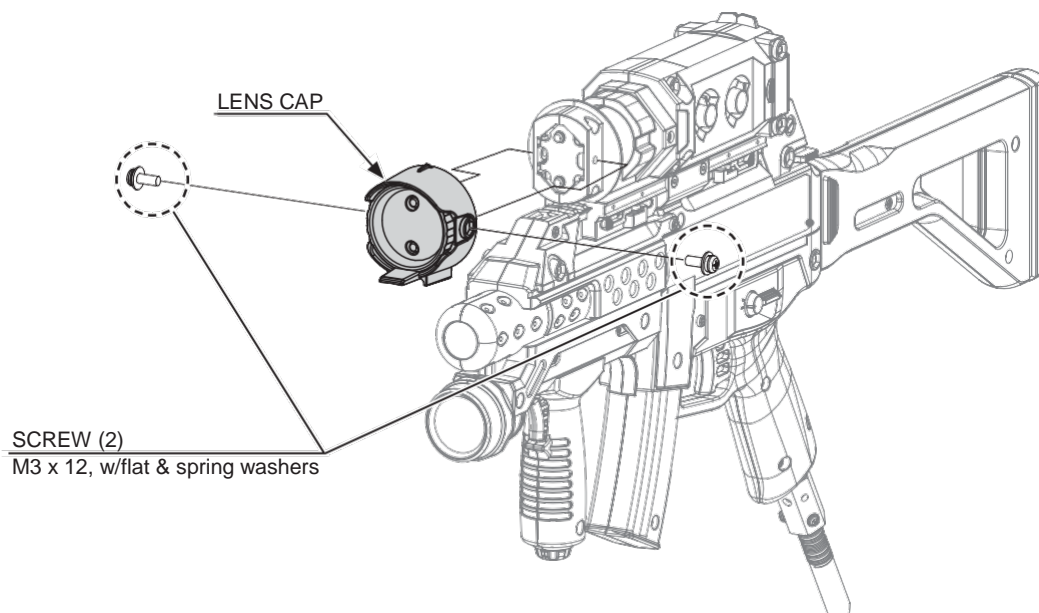

3 Remove the 7 screws and take off the scope body L.

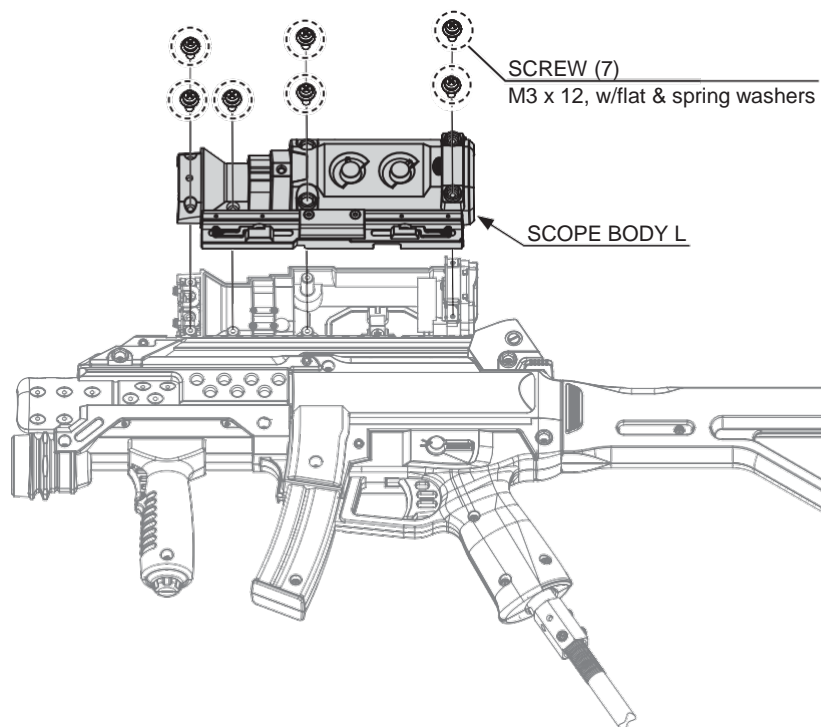

4 Remove the 1 screws and undo the 1 cord clamp.

TAPPING SCREW (1)
M4 x 8

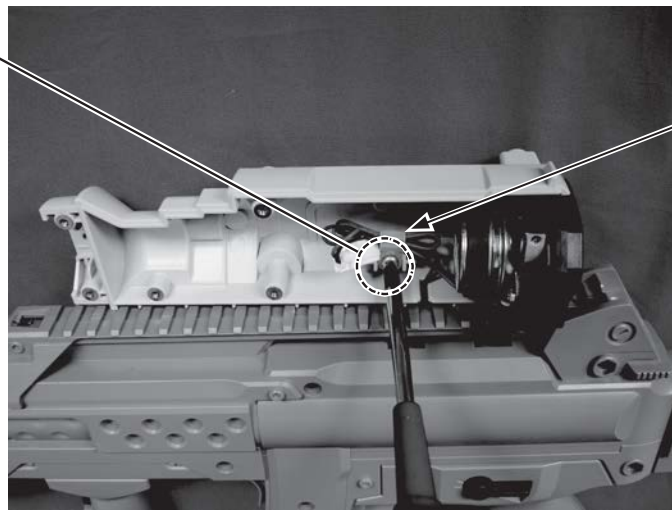

CORD CLAMP (1)

5 Disconnect the 1 connector.

CONNECTOR (1)
PA2P

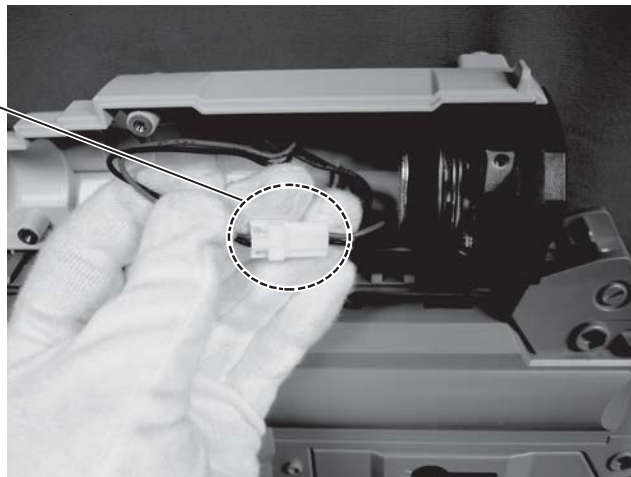

6 Remove the scope body R from the control unit. At this point, the speaker net and speaker come loose easily, so be careful not to lose them.

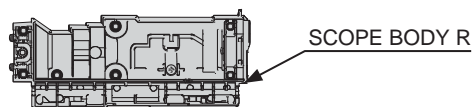

SCOPE BODY R

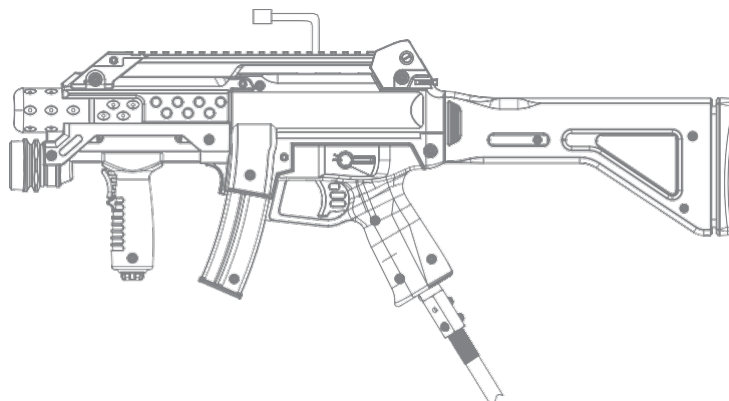

6-3 REMOVING THE MICROSWITCH

There are microswitches for the trigger and shot selector and action button inside the control unit.

1 Refer to 14-2 "REMOVING THE CONTROLLER SUPPORT" and 14-3 "REMOVING THE SCOPE," take off the controller support and scope body.

2 Place cover R face down on the work surface and remove the 15 screws to take off the cover L.

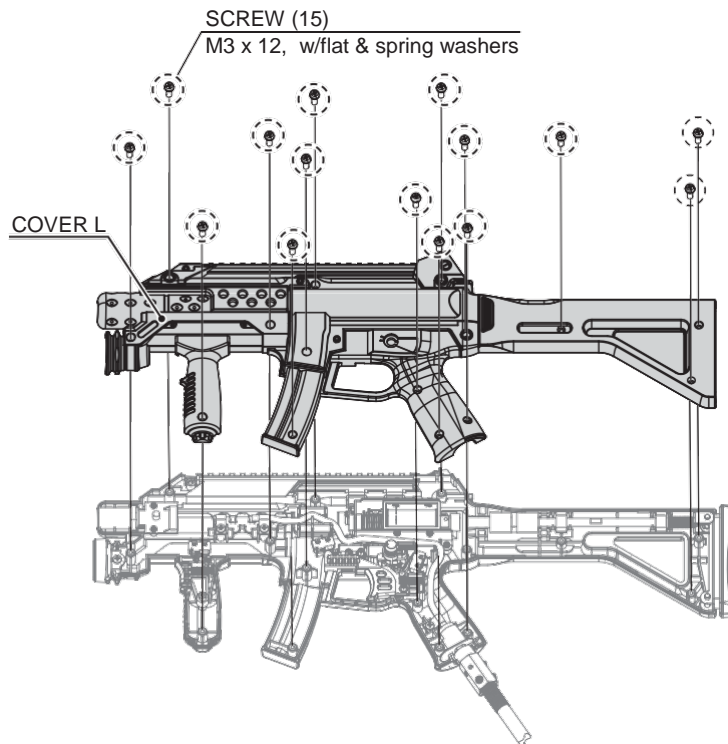

3 Remove the microswitch from the R cover.

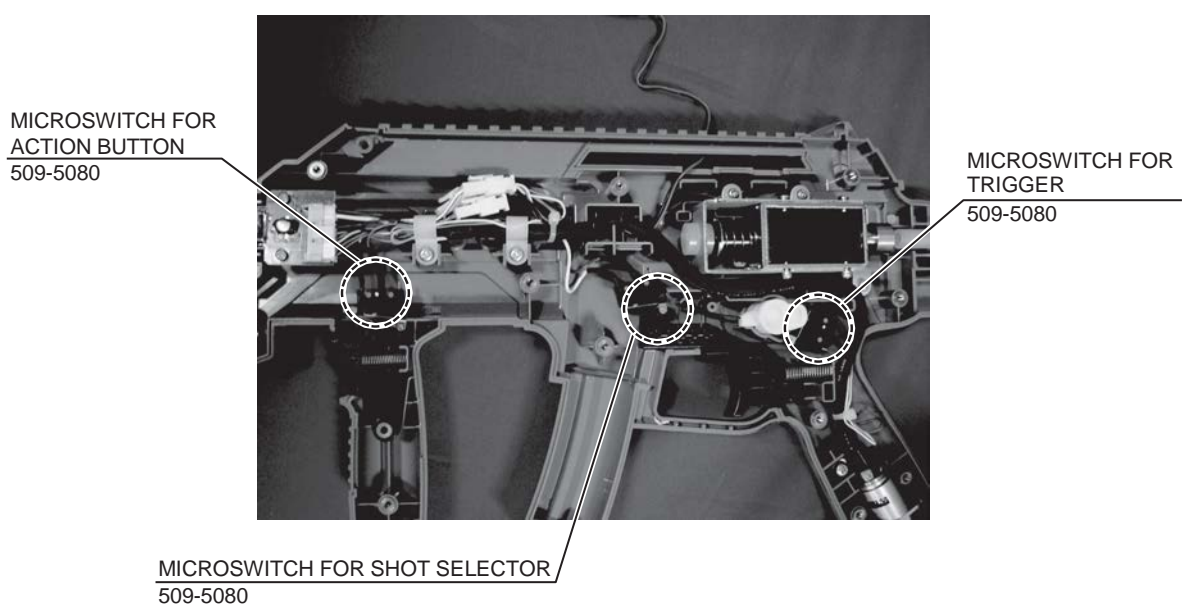

-
- 4** Remove the soldered part and then remove the microswitch.

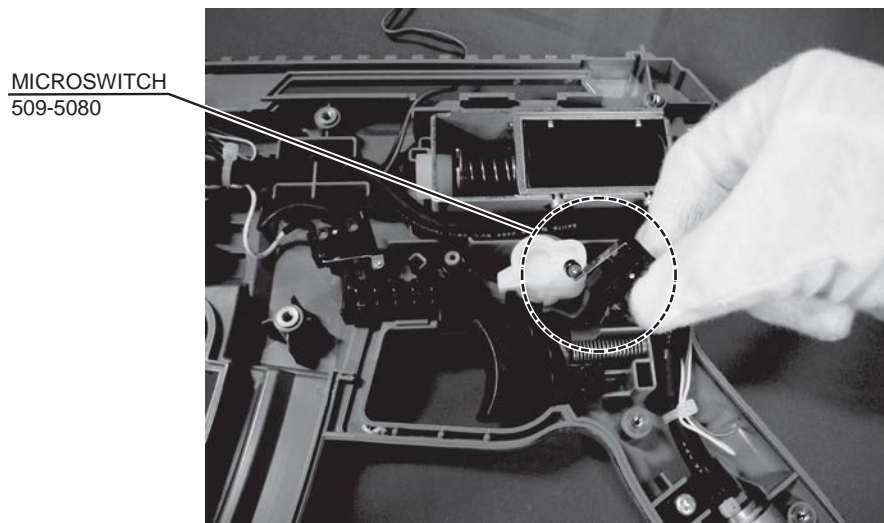

-
- 5** Solder and attach the new microswitch. Protect the soldered part with heat-shrinkable tubing.

-
- 6** Refer to Step 1 to 4 and work in reverse order to reassemble the control unit. Be careful not to tighten screws excessively.

-
- 7** Carry out an input test, controller adjustment and speaker test, and adjust the operation of each of the components.
(See chapter 9)

6-4 REPLACING THE SOLENOID

- 1 Refer to 14-2 “REMOVING THE CONTROLLER SUPORT” and 14-3 “ REMOVING THE SCOPE,” take off the controller support and scope body.
- 2 Refer to Step 2 of 14-4 “REPLACING THE MICROSWICH” and take off the cover L.
- 3 Disconnect the 1 connector.

CONNECTOR (1)
SM2P

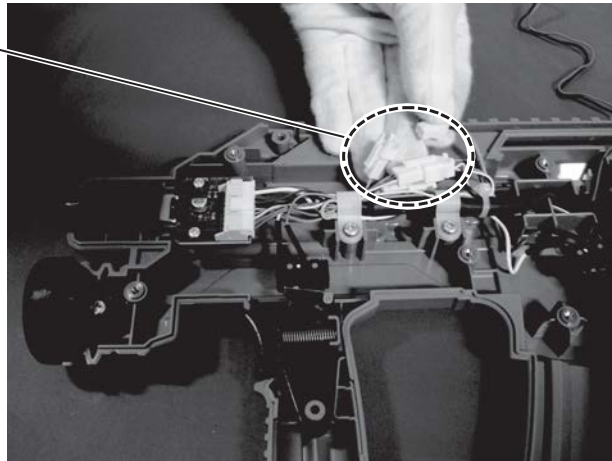

- 4 Remove the 4 screws and take off the solenoid. Be careful not lose the spring and other small parts.

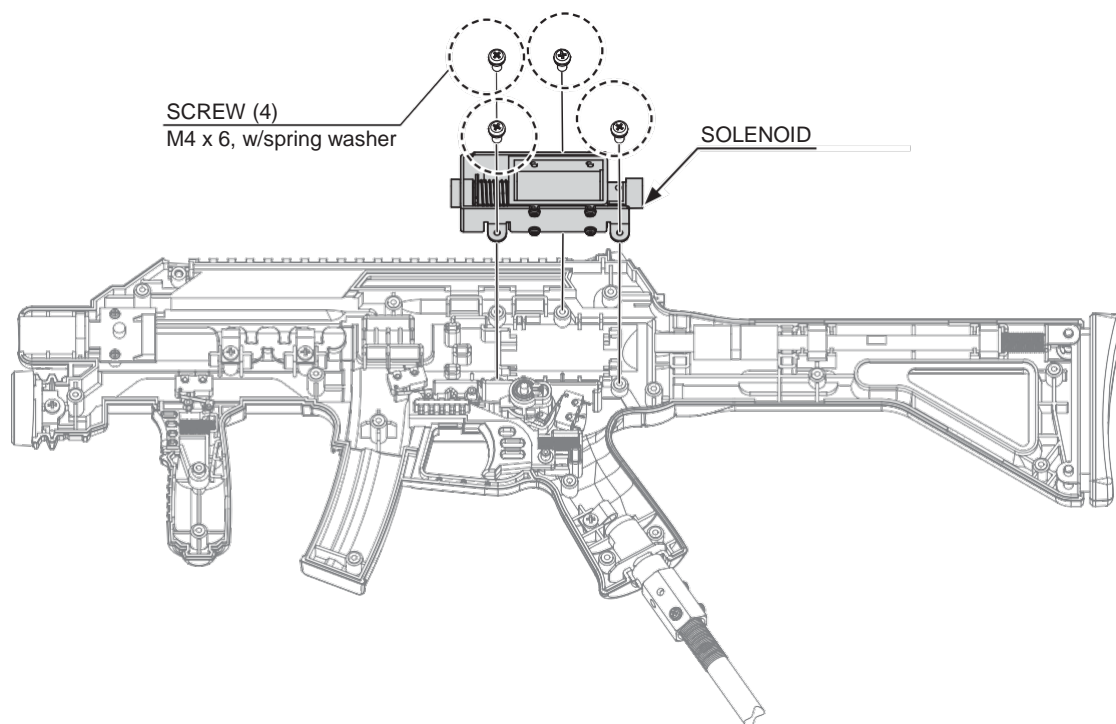

5

Remove the 8 screws and replace the solenoid.

NOTE: When attaching it, use a thread sealant.

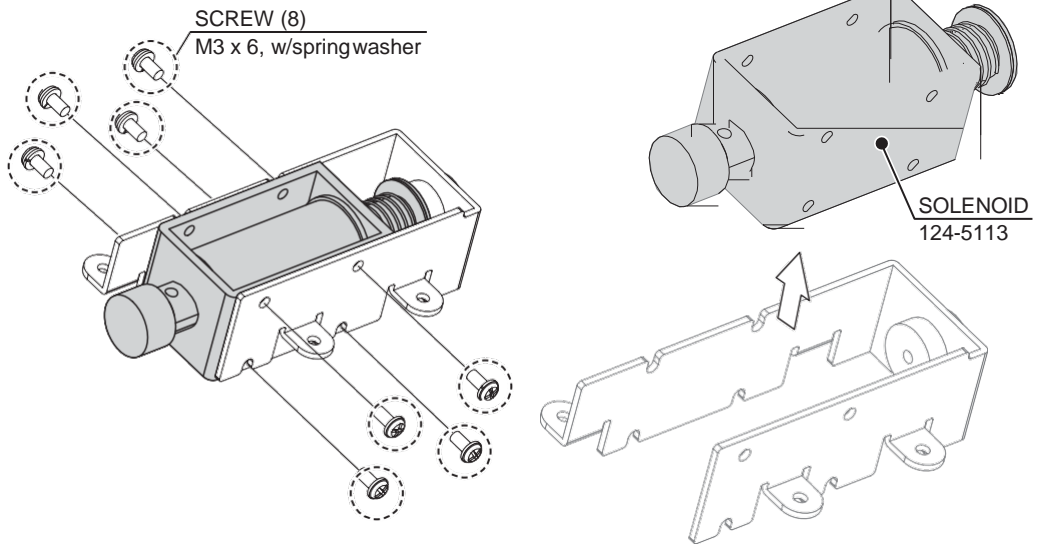

7 COIN HANDLING

Handling the Coin Jam

If the coin is not rejected when the REJECT button is pressed, open the coin chute door and open the selector gate. After removing the jammed coin, put a normal coin in and check to see that the selector correctly functions.

7-1 CLEANING THE COIN SELECTOR

STOP IMPORTANT

- Remove and clean smears by using a soft cloth dipped in water or diluted chemical detergent and then squeezed dry.
- Never apply machine oil, etc. to the Coin Selector.
- After cleaning the Coin Selector, insert a regular coin in the normal working status and ensure that the selector correctly functions.

The Coin Selector should be cleaned once every 3 months.
When cleaning, follow the procedure below:

- 1 Turn the power for the machine OFF. Open the Coin Chute Door
- 2 Remove the Coin Selector from the Coin Chute Door
- 3 Open the gate and dust off by using a soft brush (Small soft Paint Brush, etc.)

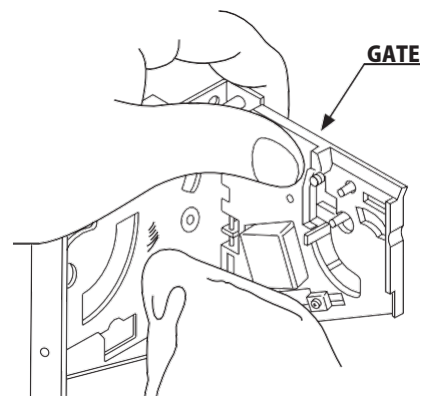

CLEANING THE COIN SELECTOR (MECHANICAL).

1 Remove and clean smears by using a soft cloth dipped in water or diluted chemical detergent and then squeezed dry.

2 Remove the CRADLE.. When removing the retaining ring (E ring) be very careful so as not to bend the rotary shaft.

3 Remove stain from the rotary shaft and shaft receiving portions by wiping off with a soft cloth. etc.

4 After wiping off as per previous step, further apply a dry cloth to completely dry the Coin Selector.

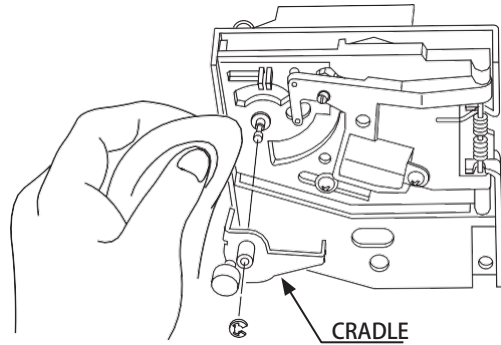

Coin Insertion Test

Once every month, when performing the Coin SW Test, simultaneously check the following:

Does the Coin Meter count satisfactorily?

Does the coin drop into the cashbox correctly?

Is the coin rejected when inserted while keeping the REJECT Button pressed down?

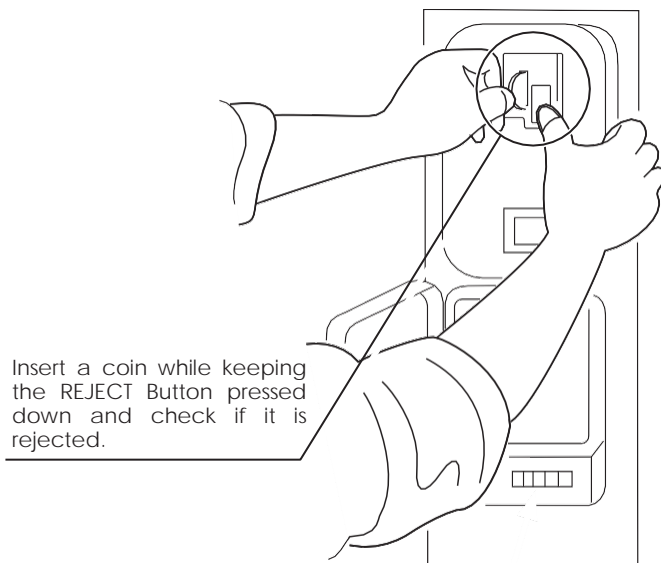

CLEANING THE COIN SELECTOR (SR3 / NRI)

- 1** Remove and clean smears by using a damp soft cloth dipped in water. **DO NOT** use any diluted chemical detergent or cleansing agent as this will impair the workings of the component.

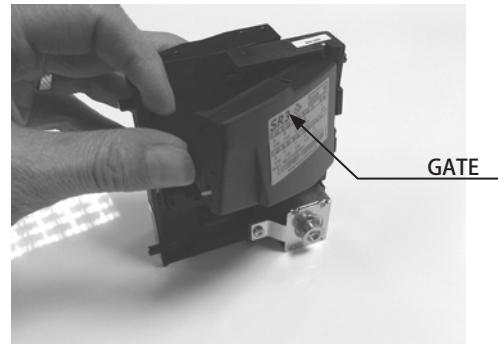

- 2** Open the reject gate to gain access to the rundown path.

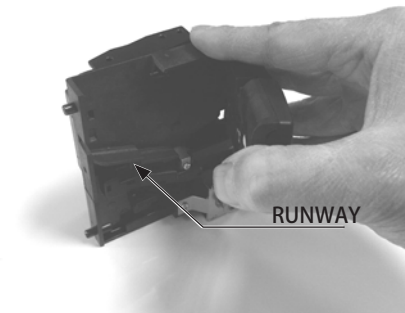

- 3** Remove the dirt and stains from the runway by wiping off with a soft damp cloth.

- 4** After wiping off as per previous step, further apply a dry cloth to completely dry the coin Selector.



7-2 FAULT FINDING

Fault Finding

The following information is presented for customers' guidance in rectifying a fault but does not cover all possible causes.

All acceptors with electronic faults should be returned to an approved service centre for repair.

SYMPTOM	INVESTIGATE	POSSIBLE CAUSE	
Acceptor does not work (all coins reject)	Connector	Poor Contact	
		Loose Wire	
	Power Supply	Not switched on	
		Incorrect voltage	
		Inadequate current	
		Rise time too slow	
	Inhibit all inputs	Acceptor Inhibited	
		Accept gate	Gate not free or dislocated
		Accept channel	Obstruction
		Reject gate	Not fully closed
	LED on rear cover RED	EEPROM chksm error	
		SR Sensor fault	
		Credit opto fault	
Credit sensor blocked			
LED on rear cover YELLOW	Reject lever pressed		
	Reinstall power		
Poor Acceptance	Power Supply	Voltage less than 10v (Voltage drops when coil engages)	
	Accept gate	Gate jam or dislocated	
	Connector	Loose	
	Coin rundown	Dirty	
	Bank Select	Both banks enabled	
Coin stick or jam in acceptor.	Accept channel	Acceptor dirty or may have some damage	
	Accept gate		
	Reject gate		
A true coin type rejects	Label	Coin not programmed	
No accept signal	Connector	Loose or broken wire	
	Accept channel	Path dirty or obstructed	

7-3 ADJUSTING THE PRICE OF PLAY (EXCEL)

STOP IMPORTANT

- The price of play is determined by the configuration of switches located on either an EXCEL board or VTS board. The type of board used is determined by product location. Switch settings for both types of board remain the same.

This product comes equipped with a Crane NRI Coin Acceptor. To adjust the price of play ALL credit setting are adjusted via the EXCEL CREDIT BOARD.

IMPORTANT!

The CREDIT SETTINGS within the SYSTEM TEST MODE must be set to 1 coin 1 credit to allow the CREDIT BOARD to function correctly.

The CREDIT BD has a built accumulator. This is controlled by 2 DIL Switches. These allow the operator to select the price of play, type of coin acceptor and region.

EXCEL Credit Board

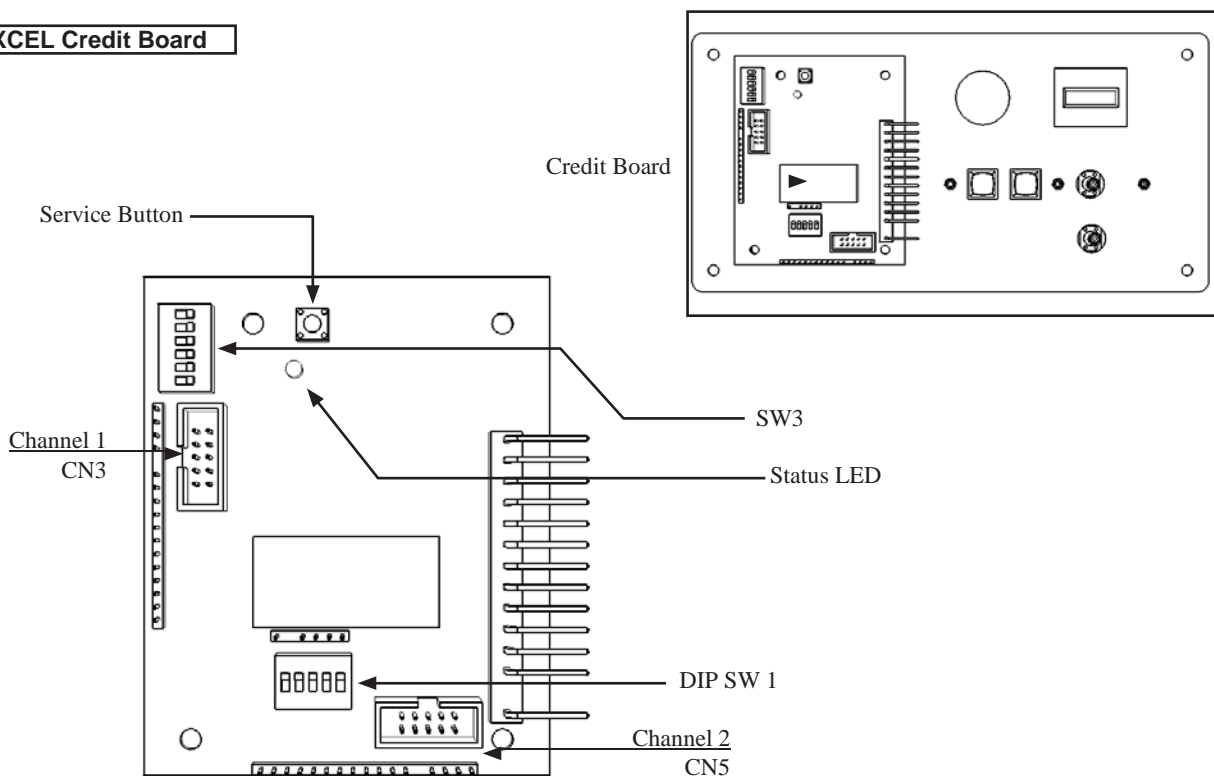

DIL SW3 (Regional Settings)

Adjust these switches to specify the type of Coin Acceptor used and currency.

Default = SW1&SW2 ON - SR3/NRI in parallel mode, Sterling.

SERVICE BUTTON Provides a SERVICE CREDIT when pressed

Status LED

CHANNEL 1

DIL SW1 (credit settings)

Flashes when functioning.

To Coin Acceptor (SR3 TYPE.)

Adjust to required price of pay.

MAIN VOLUME ADJUSTMENT (FRONT SPEAKERS)

STERLING PRICE OF PLAY SETTINGS (SW1)

	Price	Bonus					DIL Switch 1				
							1	2	3	4	5
1	10p	50p = 5 plays	£1 = 10 plays	£2 = 20 plays		OFF	OFF	OFF	OFF	OFF	
2	10p	50p = 6 plays @ 8.33p per play	£1 = 12 plays @ 8.33p per play	£2 = 24 plays @ 8.33p per play		ON	OFF	OFF	OFF	OFF	
3	20p	50p = 2.5 plays	£1 = 5 plays	£2 = 10 plays		OFF	ON	OFF	OFF	OFF	
4	20p	50p = 3 plays @ 16.66p per play	£1 = 6 plays @ 16.66p per play	£2 = 12 plays @ 16.66p per play		ON	ON	OFF	OFF	OFF	
5	30p	50p = 1.66 plays	£1 = 3.33 plays	£2 = 6.66 plays		OFF	OFF	ON	OFF	OFF	
6	30p	50p = 1.66 plays	£1 = 4 plays @ 25p per play	£2 = 8 plays @ 25p per play		ON	OFF	ON	OFF	OFF	
7	30p	50p = 2 plays @ 25p per play	£1 = 4 plays @ 25p per play	£2 = 8 plays @ 25p per play		OFF	ON	ON	OFF	OFF	
8	30p	50p = 2 plays @ 25p per play	£1 = 3 plays @ 33.33p per play	£2 = 6 plays @ 33.33p per play		ON	ON	ON	OFF	OFF	
9	40p	50p = 1.25 plays	£1 = 2.5 plays	£2 = 5 plays		OFF	OFF	OFF	ON	OFF	
10	40p	50p = 1.25 plays	£1 = 3 plays @ 33.3p per play	£2 = 6 plays @ 33.3p per play		ON	OFF	OFF	ON	OFF	
11	50p	50p = 1 play	£1 = 2 plays	£2 = 4 plays		OFF	ON	ON	OFF	OFF	
12	50p	50p = 1 play	£1 = 3 plays @ 33.3p per play	£2 = 6 plays @ 33.3p per play		ON	ON	OFF	ON	OFF	
13	50p	50p = 1 play	£1 = 2 plays	£2 = 5 plays @ 40p per play		OFF	OFF	ON	ON	OFF	
14	60p	50p = 0.83 play	£1 = 1.66 plays	£2 = 3.33 plays		ON	OFF	ON	ON	OFF	
15	60p	50p = 0.83 play	£1 = 2 plays @ 50p per play	£2 = 4 plays @ 50p per play		OFF	ON	ON	ON	OFF	
16	80p	50p = 0.62 play	£1 = 1.25 plays	£2 = 2.5 plays		ON	ON	ON	ON	OFF	
17	80p	£1 = 1.25 plays	£1.50 = 2 plays @ 75p per play	£2 = 2.5 plays		OFF	OFF	OFF	OFF	ON	
18	£1	2x50p = 1 play	£1 = 1 play	£2 = 2 plays		ON	OFF	OFF	OFF	ON	
19	£1	2x50p = 1 play	£1 = 1 play	£2 = 3 plays @ 66.6p per play		OFF	ON	OFF	OFF	ON	
20	£1	2x50p = 1 play	£2 = 2 plays	£4 = 5 plays @ 80p per play		ON	ON	OFF	OFF	ON	
21	£1.50	3x50p = 1 play	£1 = 0.66 plays	£3 = 2 plays		OFF	OFF	ON	OFF	ON	
22	£1.50	3x 50p = 1 play	£1 = 0.66 plays	£2 = 2 plays @ £1 per play		ON	OFF	ON	OFF	ON	
23	£2	4x 50p = 1 play	£1 = 0.5 play	£2 = 1 play		OFF	ON	ON	OFF	ON	
24	£2	4x 50p = 1 play	£1 = 0.5 play	£5 = 3 plays @ £1.66 per play		ON	ON	ON	OFF	ON	
25	£3	6x50p = 1 play	£1.50 = 0.5 play	£3 = 1 play		OFF	OFF	OFF	ON	ON	
26	£3	6x50p = 1 play	£1.50 = 0.5 play	£5 = 2 plays @ £2.50 per play		ON	OFF	OFF	ON	ON	
27	£5	£1 = 0.2 play	£5 = 1 play	£10 = 2 plays		OFF	ON	OFF	ON	ON	
28	£5	£1 = 0.2 play	£5 = 1 play	£10 = 3 plays @ £3.33p per play		ON	ON	OFF	ON	ON	
29	£7.50	£5 = 0.66 play	£10 = 1.33 plays	£15 = 2 plays		OFF	OFF	ON	ON	ON	
30	£7.50	£5 = 0.66 play	£10 = 1.33 plays	£10 = 2 plays @ £5 per play		ON	OFF	ON	ON	ON	
31	£10	£10 = 1 play	£20 = 2 play	£30 = 3 play		OFF	ON	ON	ON	ON	
32			Free Play			ON	ON	ON	ON	ON	

EURO PRICE OF PLAY SETTINGS (SW1)

Price	Bonus					DIL Switch 1				
						1	2	3	4	5
10¢	50¢ = 5 plays	€1 = 10 plays	€2 = 20 plays			OFF	OFF	OFF	OFF	OFF
10¢	50¢ = 6 plays @ 8.33p per play	€1 = 12 plays @ 8.33¢ per play	€2 = 24 plays @ 8.33¢ per play			ON	OFF	OFF	OFF	OFF
20¢	50¢ = 2.5 plays	€1 = 5 plays	€2 = 10 plays			OFF	ON	OFF	OFF	OFF
20¢	50¢ = 3 plays @ 16.66¢ per play	€1 = 6 plays @ 16.66¢ per play	€2 = 12 plays @ 16.66¢ per play			ON	ON	OFF	OFF	OFF
30¢	50¢ = 1.66 plays	€1 = 3.33 plays	€2 = 6.66 plays			OFF	OFF	ON	OFF	OFF
30¢	50¢ = 1.66 plays	€1 = 4 plays @ 25¢ per play	€2 = 8 plays @ 25¢ per play			ON	OFF	ON	OFF	OFF
30¢	50¢ = 2 plays @ 25¢ per play	€1 = 4 plays @ 25¢ per play	€2 = 8 plays @ 25¢ per play			OFF	ON	ON	OFF	OFF
30¢	50¢ = 2 plays @ 25¢ per play	€1 = 3 plays @ 33.33¢ per play	€2 = 6 plays @ 33.33¢ per play			ON	ON	ON	OFF	OFF
40¢	50¢ = 1.25 plays	€1 = 2.5 plays	€2 = 5 plays			OFF	OFF	OFF	ON	OFF
40¢	50¢ = 1.25 plays	€1 = 3 plays @ 33.33¢ per play	€2 = 6 plays @ 33.33¢ per play			ON	OFF	OFF	ON	OFF
50¢	50¢ = 1 play	€1 = 2 plays	€2 = 4 plays			OFF	ON	OFF	ON	OFF
50¢	50¢ = 1 play	€1 = 3 plays @ 33.33¢ per play	€2 = 6 plays @ 33.33¢ per play			ON	ON	OFF	ON	OFF
50¢	50¢ = 1 play	€1 = 2 plays	€2 = 5 plays @ 40¢ per play			OFF	OFF	ON	ON	OFF
60¢	50¢ = 0.83 play	€1 = 1.66 plays	€2 = 3.33 plays			ON	OFF	ON	ON	OFF
60¢	50¢ = 0.83 play	€1 = 2 plays @ 50¢ per play	€2 = 4 plays @ 50¢ per play			OFF	ON	ON	ON	OFF
80¢	50¢ = 0.62 play	€1 = 1.25 plays	€2 = 2.5 plays			ON	ON	ON	ON	OFF
80¢	£1 = 1.25 plays	€1 = 1.50 = 2 plays @ 75¢ per play	€2 = 2.5 plays			OFF	OFF	OFF	OFF	ON
€1	2x50¢ = 1 play	€1 = 1 play	€2 = 2 plays			ON	OFF	OFF	OFF	ON
€1	2x50¢ = 1 play	€1 = 1 play	€2 = 3 plays @ 66.6¢ per play			OFF	ON	OFF	OFF	ON
€1	2x50¢ = 1 play	€2 = 2 plays	€4 = 5 plays @ 80¢ per play			ON	ON	OFF	OFF	ON
€1.50	3x50¢ = 1 play	€1 = 0.66 plays	€3 = 2 plays			OFF	OFF	ON	OFF	ON
€1.50	3x50¢ = 1 play	€1 = 0.66 plays	€2 = 2 plays @ €1 per play			ON	OFF	ON	OFF	ON
€2	4x50¢ = 1 play	€1 = 0.5 play	€2 = 1 play			OFF	ON	ON	OFF	ON
€2	4x50¢ = 1 play	€1 = 0.5 play	€5 = 3 plays @ €1.66 per play			ON	ON	ON	OFF	ON
€3	6x50¢ = 1 play	€1.50 = 0.5 play	€3 = 1 play			OFF	OFF	OFF	ON	ON
€3	6x50¢ = 1 play	€1.50 = 0.5 play	€5 = 2 plays @ €2.50 per play			ON	OFF	OFF	ON	ON
€5	€1 = 0.2 play	€5 = 1 play	€10 = 2 plays			OFF	ON	OFF	ON	ON
€5	€1 = 0.2 play	€5 = 1 play	€10 = 3 plays @ 3.33¢ per play			ON	ON	OFF	ON	ON
€7.50	€5 = 0.66 play	€10 = 1.33 plays	€15 = 2 plays			OFF	OFF	ON	ON	ON
€7.50	€5 = 0.66 play	€10 = 1.33 plays	€10 = 2 plays @ €5 per play			ON	OFF	ON	ON	ON
€10	€10 = 1 play	€20 = 2 play	€30 = 3 play			OFF	ON	ON	ON	ON
32	Free Play					ON	ON	ON	ON	ON

7-4 NRI OPTIONS - STERLING / EURO SELECT

SELECTING STERLING / EURO OPTION

The NRI coin acceptor (supplied) is programmed to accept UK Sterling and the Euro. Factory setting is for the UK Sterling. If the configuration needs to change to the Euro, then please follow the instructions below for changing over to the Euro and visa versa.

- Coin Information - Memory Block 0 (DIL switch S1.10 is set to OFF)
- Memory Block 1 (DIL switch S1.10 is set to ON)

If the coin validator is to access the other memory block and, e.g., accept euro coins instead of national currency coins, the correct block can be selected using the upper switching block:

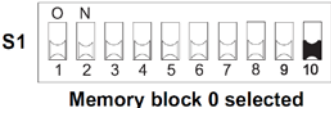

Sterling selection

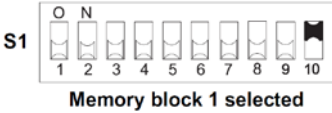

Euro selection

To select memory block 0, (STERLING) move DIL switch S1.10 of the upper switching block to the bottom OFF position, for memory block 1, move it to the ON position.

7-5 NRI OPTIONS - TEACH AND RUN PROGRAMMING

TEACH AND RUN PROGRAMMING (NRI)

If the machine is positioned in location where only tokens are used, then the NRI Coin Acceptor can be programmed to accept and credit special coins/tokens.

Please follow the instructions below to enable and program the TEACH & RUN facility.

TEACHING COIN CHANNELS USING TEACH MODE

In order to generate new acceptance bands you can teach up to eight coin channels using the lower switching block on the coin validator. You will need at least ten coins of the new type. There is a different switch assignment for the double and single block data-management:

Switching block S2 (with double block data-management)

DIL switch		off	on
S2.1	Coin channel 9		teach
S2.2	Coin channel 10		teach
S2.3	Coin channel 11		teach
S2.4	Coin channel 12		teach
S2.5	Coin channel 13		teach
S2.6	Coin channel 14		teach
S2.7	Coin channel 15		teach
S2.8	Coin channel 16		teach
S2.9	Teach mode	switch off	switch on
S2.10	Acceptance band	normal	wide

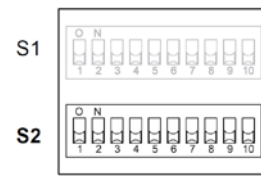

By default, the eight teach channels have been programmed, so that one coin impulse is transmitted to the machine via coin signal line 6, when a new coin is accepted.

8 LAMPS AND LIGHTING

⚠ WARNING

- When working with the product, be sure to turn the power off. Working with the power on may cause an electric shock or short circuit.
- You may get burned by a hot fluorescent lamp or other lamps. Pay full attention to the lamps when performing the work.
- Be sure to use lamps of the designated rating. Using lamps of undesignated rating can cause a fire or malfunctioning.
- There is the danger of short circuits or smoke generation due to deterioration of insulation in lighting fixtures resulting from age deterioration. Check for anomalies such as the following: Does it smell like something is burning? Is there socket discoloration? Are any lamps being replaced frequently? Do lamps not go on properly?

⚠ CAUTION

The Coin Door Lamp utilises a 12v 1.2w Wedge Bulb. It is important that you replace this bulb or any other bulb of that of the same voltage and rating. Failing to observe this caution may result in PCB failure or possible fire hazard.

8-1 COIN DOOR LAMP

Step 1. Open the Coin Door and locate the Lamp Housing directly behind the Coin Insert Bezel. Lamp Housing

Step 2. Hold the Lamp Housing firmly between your index finger and thumb and gently pull upwards. Do Not try to remove the Lamp Housing whilst holding the bulb as the bulb may break causing injury.

Step 3. Once the Lamp Housing has been removed, carefully hold the bulb between your fingers and pull the Lamp Housing away.

Do not twist either bulb or Lamp Housing whilst removing the bulb as this may cause damage to both bulb and or Housing.

Type: Wedge Bulb - 12v, 1.2w

Step 4. Simply push-fit a replacement bulb of the same type and follow these steps in reverse to refit.



9 PERIODIC INSPECTION

The items listed below require periodic check and maintenance to retain the performance of this machine and to ensure safe business operation.

When handling the controller, the player will be in direct contact with it. In order to always allow the player to enjoy the game, be sure to clean it regularly. Also, it is advisable to provide wet tissue, etc. available for player use.

WARNING

- Every 6 months check to see if power cords are damaged, the plug is securely inserted, dust is accumulated between the socket outlet and the power plug, etc. Using the product with accumulated dust in the interior may cause fire or electric shock.
- Never use a water jet, etc. to clean the inside and outside of the cabinet. If wetness occurs for any reason, do not use the product until it has completely dried.
- Once a year, request the office shown on this manual or the dealer from whom the product was originally purchased to perform the internal cleaning. Using the product with accumulated dust in the interior may cause fire or other accidents.
- Note that you are liable for the cost of cleaning the interior parts.
- There is the danger of accidents involving electrical shorts circuits or fire caused by factors such as the deterioration of insulation in electrical and electronic equipment over time. Check that there are no abnormalities such as odors from burning.

9 TABLE 01 PERIODIC INSPECTION TABLE

PERIOD	ITEM	DESCRIPTION	REFERENCE
As appropriate	Cabinet surface Control unit Surface	Cleaning	As Below
Daily	Cabinet	Confirm that adjusters are in contact with the floor	
Weekly	Control Unit	Aim Test	
	LCD	Screen Cleaning Screen Alignment	
Monthly	Front Cabinet	Speaker volume	
	Controller Cabinet	Check Input devices	
		Check Output devices	
	Controller Unit	Check Speaker Volume	
		Speaker inspection	
		Check each input device Check each output device	
LED board	LED Inspection		
Coin Selector	Coin path inspection		
	Coin Insertion Test		
Every 3 Months	Coin Selector	Cleaning	
1 Year	Ringwide	Cleaning	
	Power Cables	Inspection / Cleaning	
	Cabinet Interior	Cleaning	

Cleaning the Cabinet Surfaces

When the cabinet surfaces are badly soiled, remove stains with a soft cloth dipped in water or diluted (with water) chemical detergent and squeezed dry. To avoid damaging surface finish, do not use such solvents as thinner, benzine, etc. other than ethyl alcohol, or abrasives, bleaching agent and chemical dustcloth.

Some general-purpose household, kitchen and furniture cleaning products may contain strong solvents that degrade plastic components, coatings, and print. Before using any cleaning product, read the product's cautionary notes carefully and test the product first on a small area that is not highly visible.

10 TROUBLESHOOTING

10-1 TROUBLESHOOTING (WHEN NO ERROR MESSAGE IS SHOWN)

WARNING

- This work should be performed by site maintenance personnel or other skilled professionals. Work performed by non-technical personnel can cause a severe accident such as an electric shock. If there are no site maintenance personnel or other skilled professionals available, turn off the power immediately and contact the office given in this manual or from point-of-purchase.
- When working with the product, be sure to turn the power off. Working with the power on may cause an electric shock or short circuit accident.
- In order to prevent electric shock and short circuit, be sure to turn power off before performing work.
- Be careful so as not to damage wirings. Damaged wiring can cause electric shock or short circuit.
- After removing the cause of the functioning of the Circuit Protector, reinstate the Circuit Protector. Depending on the cause of the functioning, using the Circuit Protector as is without removing the cause can cause generation of heat and fire hazard.
- In the event that a problem cannot be resolved by employing the procedures listed in this Manual, be sure to request service from the office shown on this Manual or the dealer from whom the product was originally purchased. Attempts to employ procedures other than those specified in this Manual can cause electrical shock, shorting, or fire.
- In the event of a problem that is not described here, be sure to contact the office shown on this Manual or the dealer from whom the product was originally purchased. Careless attempts at repair can result in electrical shock, shorting, or fire.

IMPORTANT

- If an error message is displayed, identify the cause and without delay take the appropriate countermeasures. Leaving the error unaddressed could result in a breakdown.
- If a problem occurs, first inspect the connection of any wiring connectors.
- Static electricity from your body may damage some electronic devices on the IC board. Before handling any IC board, touch a grounded metallic surface so that static electricity is discharged.

If a problem occurs, first check to make sure that the wiring connectors are properly connected.

PROBLEM	CAUSE	COUNTERMEASURES
When the main SW is turned ON, the machine is not activated.	The power is not ON.	Firmly insert the plug into the outlet.
	Incorrect power source/voltage.	Make sure that the power supply/voltage are correct.
	The Fuse on the AC Unit has blown due to momentary over current.	After eliminating the cause of overload, replace the specified rating fuse.
	The fuse of the connect board has blown due to momentary over current.	After eliminating the cause of overload, replace the specified rating fuse.
No sound is generated from the speakers.	Volume not correctly adjusted.	Adjust the sound volume. (see chapter 9)
	Game Bd or Amplifier malfunction.	Call service dept mentioned in this manual.
LCD colour incorrect.	Screen not correctly adjusted	Adjust the screen (see chapter 11)
	VGA cable malfunction	Replace VGA cable
	LCD failure	Call service dept mentioned in this manual.
The controller line of sight is not acceptable.	Sights are not aligned due to changes in the surrounding enviroment	Re-align the sight settings (see chapter 9)
	Sight LED board malfunction.	Check LED bds positioned around the screen - check that all LEDs are lit. <i>(This can be easily achieved if viewing LED through a digital device i.e camera or camera phone.)</i>
	Sensor unit malfunction	Replace sensor unit. (see chapter 10)
	LED Board / cover contaminated	Clean both LED covers and LEDs
The controller unit does not to appear to operate correctly.	Microswitch failure.	Check using Input Test (see chapter 9) to establish operation.
	LED board malfunction.	Check LED bds positioned around the screen - check that all LEDs are lit. <i>(This can be easily achieved if viewing LED through a digital device i.e camera or camera phone.)</i>
	Sensor Unit malfunction	Replace the Sensor Unit (see chapter 10)

11 GAME BOARD (RINGWIDE)

WARNING

- When working with the product, be sure to turn the power off. Working with the power on may cause an electric shock or short circuit.
- Be careful not to damage the wires. Damaged wires may cause an electric shock, short circuit or present a risk of fire.
- Do not use this product with connectors other than those that were connected and used with the game board at the time of shipping. Do not carelessly connect wires to connectors that were not used at the time of shipping, as this may cause overheating, smoke or fire damage.

CAUTION

In this product, setting changes are made during the test mode. The game board need not be operated. Use the game board, etc. as is with the same setting made at the time of shipment so as not to cause electric shock and malfunctioning.

IMPORTANT

Static electricity from your body may damage some electronics devices on the IC board. Before handling the IC board, touch a grounded metallic surface so that the static electricity can be discharged.

11-1 HANDLING PRECAUTIONS

WARNING

- To prevent electric shock or IC Board malfunctioning, be sure to turn off the power for the cabinet when installing or removing the IC Board.
- Extraneous matter such as dust on the IC Board can cause the IC Board to generate heat and result in a fire due to short circuit, etc. Ensure the IC Board surfaces are always kept clean.
- Keep the IC board well cooled. RINGWIDE is provided with ventilating fans. Do not block the air outlets of these fans. Also do not place anything closely to RINGWIDE. Failure to observe these instructions may cause an overheating and fire.
- Always follow the usage conditions from SEGA as well as the usage conditions for the cabinet you are using for RINGWIDE. Failure to do so may cause an overheating and fire.

IMPORTANT

- Be sure to connect the IC Board and connectors completely. Insufficient insertion can damage IC Board, etc.
- For the IC Board circuit inspection, only the use of Logic Tester is permitted. The use of ordinary testers is not permitted as these can damage the IC Board.
- Do not subject the IC Board to static electricity when installing the IC Board in the cabinet or when connecting wire harness connectors to the IC Board.
- When soldering buttons, etc. to the wire harnesses, be sure to remove the wire harnesses from the IC Board so as not to subject the IC Board to heat.
- Using RINGWIDE without the Shield Case can cause electric wave trouble. Be sure to use RINGWIDE together with the accessory Shield Case.
- Some parts are the ones designed and manufactured not specifically for this product. The manufacturers may discontinue, or change the specifications of, such general-purpose parts. If this is the case, SEGA cannot repair or replace a failed product whether or not a warranty period has expired.

11-2 PARTS DETAILS

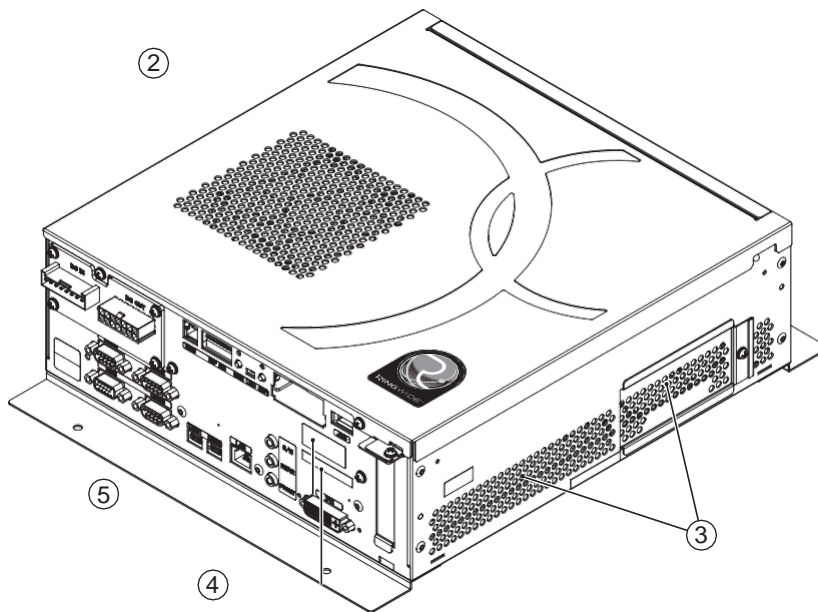
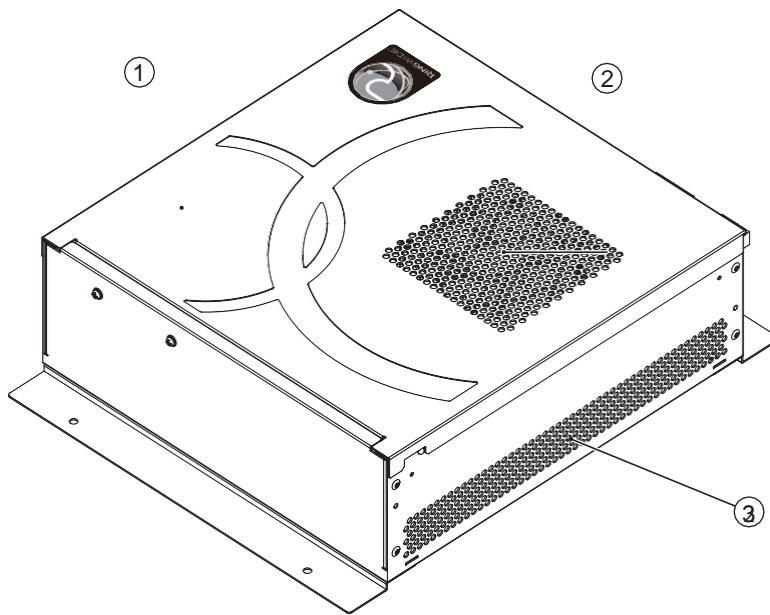

- ① Shield case
- ② Exhaust vent (Do not block or cover.)
- ③ Intake vent (Do not block or cover.)
- ④ Board number
- ⑤ Board serial number

DIP SW

No. 1, No. 2 and No.3:

Use differs depending on game software. Set according to the Service Manual provided with the game software itself.

No. 4:

Changes the facing of the monitor. Use differs depending on game software. Set according to the Service Manual provided with the game software itself. If no specific directions are given set to horizontal display (OFF).

OFF: Horizontal display

ON: Vertical display

No. 5, No. 6 and No. 7:

Set the resolution of the video output.

Use differs depending on game software. Set according to the Service Manual provided with the game software itself.

Resolution	No. 5	No. 6	No. 7
*	OFF	OFF	OFF
640 x 480	ON	OFF	OFF
1024 x 600	OFF	ON	OFF
1024 x 768	ON	ON	OFF
1280 x 720	OFF	OFF	ON
1280 x 1024	ON	OFF	ON
1360 x 768	OFF	ON	ON
1920 x 1080	ON	ON	ON

For TARGET BRAVO the resolution is 1024 x 600

No. 8:

Use differs depending on game software. Set according to the Service Manual provided with the game software itself.

The diagram below shows the setting for OPERATION GHOST

No. 1	No. 2	No. 3	No. 4	No. 5	No. 6	No. 7	No. 8
OFF	OFF	OFF	OFF	OFF	ON	OFF	OFF



11-3 RINGWIDE COMPONENTS

■ ACCESSORIES

Parts not labeled with part numbers are as yet unregistered or cannot be registered. Be sure to handle all parts with care, as some parts are not available for purchase separately.

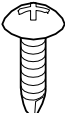
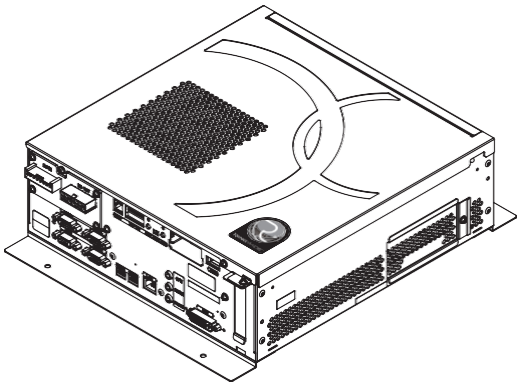
DESCRIPTION/PART NO.	FIGURES/NOTES	QTY
TAPPING SCREW 011-P00412	 Used for installing the RINGWIDE.	4
RINGWIDE 847-0001D-01 : USA 847-0001D-02 : OTHERS 847-0001D-03 : CHINA		1 ea.

11-4 ERROR CODES DISPLAY

WARNING

- If an error code is displayed get on-site maintenance personnel or other qualified professional to look at it. An unqualified person attempting to resolve an error code problem may lead to electric shock, short circuit and risk of fire.

If no on-site maintenance personnel or qualified professional is available immediately turn off the power and contact the customer services in this manual or your supplier.

- If a problem not described in this manual occurs, or the resolution to a problem described in this manual is not effective, do not make further attempts to resolve the problem yourself. Immediately turn off the power and contact the office listed in this manual or your supplier. Any unguided attempts to solve such problems may lead to a serious accident.

 STOP

IMPORTANT

If an error number or message not listed below appears, cease using the product immediately and contact the office listed in this manual or the point of purchase for this product.

RINGWIDE is equipped to display various errors on-screen to help solve any problems. If an error is displayed the game cannot be used. Use the following table of causes and countermeasures to solve the problem.

DISPLAY	Error 0001 Keychip Not Found
CAUSE	There is no key chip, or the key chip is not connected correctly.
COUNTERMEASURES	Check that the key chip is connected correctly.
DISPLAY	Error 0002 Keychip Not Available
CAUSE	The key chip is not supported. The RINGWIDE system program must be updated.
COUNTERMEASURES	Check how the game was installed. If that doesn't fix the problem, contact the office listed in this manual or the point of purchase for this product.
DISPLAY	Error 0004 Game Program Not Acceptable
CAUSE	The key chip is not supported.
COUNTERMEASURES	Check that the key chip from a different system is not inserted. If that doesn't fix the problem, contact the office listed in this manual or the point of purchase for this product.

DISPLAY	Error 0008 Keychip Access Failed
CAUSE	The key chip could not be accessed.
COUNTERMEASURES	Reinsert the key chip and restart RINGWIDE. If that doesn't fix the problem, contact the office listed in this manual or the point of purchase for this product.
DISPLAY	Error 0010 Unexpected Game Program Failure
CAUSE	The game program crashed due to an unexpected error.
COUNTERMEASURES	Turn the power off and then restart the RINGWIDE. If that doesn't fix the problem, contact the office listed in this manual or the point of purchase for this product.
DISPLAY	Error 0020 EXIO Not Found
CAUSE	The I/O board inside RINGWIDE is not recognized.
COUNTERMEASURES	Turn the power off and then restart the RINGWIDE. If that doesn't fix the problem, contact the office listed in this manual or the point of purchase for this product.
DISPLAY	Error 0021 Main board Malfunctioning
CAUSE	The main board does not recognize itself.
COUNTERMEASURES	Contact the office listed in this manual or the point of purchase for this product.
DISPLAY	Error 0022 Game Program Not Found on Storage Device
CAUSE	There is no game program on the storage device.
COUNTERMEASURES	Use the installation media (DVD DRIVE, etc.) to reinstall the game.
DISPLAY	Error 0023 - 0026 Main board Malfunctioning
CAUSE	Failed to access the main board.
COUNTERMEASURES	Turn the power off and then restart the RINGWIDE. If that doesn't fix the problem, contact the office listed in this manual or the point of purchase for this product.
DISPLAY	Error 0027 Low Battery
CAUSE	The button battery may be depleted.
COUNTERMEASURES	Replace the button battery.
DISPLAY	Error 0041 Game Program Not Found on Install Media
CAUSE	There is no game program on the install media.
COUNTERMEASURES	Check that the game program, placed on the install media (DVD DRIVE etc.), and the key chip correspond to each other.

DISPLAY	Error 0042 Game Program Not Found on Install Media
CAUSE	Some part of the game program is missing.
COUNTERMEASURES	Check how the game was installed. If that doesn't fix the problem, contact the office listed in this manual or the point of purchase for this product.
DISPLAY	Error 0049 Install Media Access Failed
CAUSE	Failed to access the install media.
COUNTERMEASURES	Check that the install media (DVD DRIVE etc.) is connected correctly. Check that the game disk is not scratched, damaged or dirty. If that doesn't fix the problem, contact the office listed in this manual or the point of purchase for this product.
DISPLAY	Error 0052 Install Media Access Failed
CAUSE	Failed to access the install media.
COUNTERMEASURES	Check that the install media (DVD DRIVE etc.) is connected correctly. Check that the game disk is not scratched, damaged or dirty. If that doesn't fix the problem, contact the office listed in this manual or the point of purchase for this product.
DISPLAY	Error 0055 Game Program Verify Error
CAUSE	The installed game program is not working correctly.
COUNTERMEASURES	Turn the power off and then restart the RINGWIDE. If that doesn't fix the problem, contact the office listed in this manual or the point of purchase for this product.
DISPLAY	Error 0064 Game Program Not Found on Server
CAUSE	No game program on the LAN install server.
COUNTERMEASURES	Check that the game program, place on the LAN install server, and the key chip correspond to each other.
DISPLAY	Error 0066 Game Program Verify Error
CAUSE	The installed game program is not working correctly.
COUNTERMEASURES	Turn the power off and then restart the RINGWIDE. If that doesn't fix the problem, contact the office listed in this manual or the point of purchase for this product.
DISPLAY	Error 0081 Invalid Storage Format
CAUSE	The storage format is wrong.
COUNTERMEASURES	Contact the office listed in this manual or the point of purchase for this product.

DISPLAY	Error 0082 Game Program Access Failed
CAUSE	The storage device cannot be recognized.
COUNTERMEASURES	Reinstall the game program. If that doesn't fix the problem, contact the office listed in this manual or the point of purchase for this product.
DISPLAY	Error 0083 Storage Device Not Acceptable
CAUSE	The storage does not have enough space.
COUNTERMEASURES	Contact the office listed in this manual or the point of purchase for this product.
DISPLAY	Error 0084 Storage Device Malfunctioning
CAUSE	The storage device may be broken.
COUNTERMEASURES	Turn the power off and then restart the RINGWIDE. If that doesn't fix the problem, contact the office listed in this manual or the point of purchase for this product.
DISPLAY	Error 0085 Invalid Storage Format
CAUSE	The storage format is wrong.
COUNTERMEASURES	Contact the office listed in this manual or the point of purchase for this product.
DISPLAY	Error 0088 System Program Verify Error
CAUSE	The installed system program is not working correctly.
COUNTERMEASURES	Perform a manual recovery of RINGWIDE. If that doesn't fix the problem, contact the office listed in this manual or the point of purchase for this product.
DISPLAY	Error 0090 High CPU Temperature
CAUSE	The CPU temperature is high.
COUNTERMEASURES	Refer to Chapter 7, and clean RINGWIDE. If that doesn't fix the problem, contact the office listed in this manual or the point of purchase for this product.
DISPLAY	Error 0091 Too High CPU Temperature
CAUSE	The CPU temperature is high.
COUNTERMEASURES	Refer to Chapter 7, and clean RINGWIDE. If that doesn't fix the problem, contact the office listed in this manual or the point of purchase for this product.
DISPLAY	Error 0501 - 0530 (No message)
CAUSE	The connected device cannot be recognized.
COUNTERMEASURES	Turn the power off and then restart the RINGWIDE. If that doesn't fix the problem, contact the office listed in this manual or the point of purchase for this product.

DISPLAY	Error 0531 (No message)
CAUSE	The connected graphics device cannot be recognized.
COUNTERMEASURES	Turn the power off and then restart the RINGWIDE. If that doesn't fix the problem, contact the office listed in this manual or the point of purchase for this product.
DISPLAY	Error 0532 (No message)
CAUSE	The connected USB device cannot be recognized.
COUNTERMEASURES	Check that the USB devices are connected correctly, and turn the power off and then restart the RINGWIDE. If that doesn't fix the problem, contact the office listed in this manual or the point of purchase for this product.
DISPLAY	Error 0533 - 0550 (No message)
CAUSE	The connected device cannot be recognized.
COUNTERMEASURES	Turn the power off and then restart the RINGWIDE. If that doesn't fix the problem, contact the office listed in this manual or the point of purchase for this product.
DISPLAY	Error 0901 Wrong Platform
CAUSE	The game board being used is not supported.
COUNTERMEASURES	Check to see if any game programs have been upgraded.
DISPLAY	Error 0902 Wrong System Program
CAUSE	It was started up with an unsupported system program. The RINGWIDE system program must be updated.
COUNTERMEASURES	Check how the game was installed. If that doesn't fix the problem, contact the office listed in this manual or the point of purchase for this product.
DISPLAY	Error 0903 Wrong Region.
CAUSE	The game is for a foreign region.
COUNTERMEASURES	Use a domestic game.
DISPLAY	Error 0905 Graphic Function Not Found
CAUSE	The RINGWIDE graphics function cannot be recognized.
COUNTERMEASURES	Check that the game program is compatible with the RINGWIDE. If it is, contact the office listed in this manual or the point of purchase for this product.

DISPLAY	Error 0906 Sound Function Not found
CAUSE	The RINGWIDE sound function cannot be recognized.
COUNTERMEASURES	Contact the office listed in this manual or the point of purchase for this product.
DISPLAY	Error 0907 Not Enough System Memory
CAUSE	RINGWIDE does not have enough memory.
COUNTERMEASURES	Contact the office listed in this manual or the point of purchase for this product.
DISPLAY	Error 0908 Not Enough SRAM
CAUSE	RINGWIDE does not have enough SRAM.
COUNTERMEASURES	Contact the office listed in this manual or the point of purchase for this product.
DISPLAY	Error 0909 Not Enough Storage Device
CAUSE	RINGWIDE does not have enough storage.
COUNTERMEASURES	Contact the office listed in this manual or the point of purchase for this product.
DISPLAY	Error 0910 Wrong Resolution Setting
CAUSE	The game does not support the current resolution settings.
COUNTERMEASURES	Change the DIP SW to the correct settings and restart the RINGWIDE.
DISPLAY	Error 0911 Wrong Horizontal/Vertical Setting.
CAUSE	The monitor horizontal/vertical settings are incorrect.
COUNTERMEASURES	Change the DIP SW to the correct settings and restart the RINGWIDE.
DISPLAY	Error 0949 Keychip Not Found
CAUSE	Failed to access the key chip.
COUNTERMEASURES	Check that the key chip is connected correctly.
DISPLAY	Error 6401 JVS I/O board is not connected to main board.
CAUSE	(1) The I/O board is not connected. (2) Unreliable connection between the game board and the I/O board.
COUNTERMEASURES	(1) Connect the I/O board to RINGWIDE. Check that the power cable is connected to I/O board. (2) Reconnect or replace the JVS cable that connects the I/O board to RINGWIDE.
DISPLAY	Error 6402 JVS I/O board does not fulfill the game spec.
CAUSE	The correct I/O board is not connected.
COUNTERMEASURES	Use an I/O board that provides the proper input/output for the game.

DISPLAY	Error 8001 Network address error (DHCP)
CAUSE	The network connection settings could not be initialized.
COUNTERMEASURES	Check the network connection and follow the startup procedures to restart the system.
DISPLAY	Error 8002 Network setting error (SYSTEM)
CAUSE	The SYSTEM TEST MODE NETWORK SETTING is incorrect.
COUNTERMEASURES	Check the NETWORK SETTING.
DISPLAY	Error 8003 Network address error (Dup.IP)
CAUSE	The network connection settings could not be initialized.
COUNTERMEASURES	Check the network connection and follow the startup procedures to restart the system.
DISPLAY	Error 8004 Network setting error (Dup.IP)
CAUSE	The SYSTEM TEST MODE NETWORK SETTING is incorrect.
COUNTERMEASURES	Check the NETWORK SETTING.
DISPLAY	Error 8005 Network type error (WAN)
CAUSE	The line type of the connected ALL.Net router is incorrect.
COUNTERMEASURES	Check the line type of the connected ALL.Net router.
DISPLAY	Error 8006 Network timeout error (DHCP)
CAUSE	The network connection settings could not be initialized.
COUNTERMEASURES	Check the network connection and follow the startup procedures to restart the system.
DISPLAY	Error 8007 Network timeout error (DNS-WAN)
CAUSE	A connection could not be established with ALL.Net.
COUNTERMEASURES	Check the RINGWIDE network connection, the in-store network connection and the connection between the ALL.Net router and the network cable, and then follow the startup procedures to restart the system. If the error persists, check the maintenance information.
DISPLAY	Error 8008 Network timeout error (DNS-LAN)
CAUSE	A connection could not be established with the ALL.Net router.
COUNTERMEASURES	Check the RINGWIDE network connection and the in-store network ALL.Net connection and then follow the startup procedures to restart the system.
DISPLAY	Error 8009 Network Game Disabled
CAUSE	The GAME TEST MODE ALL.Net connection is set to OFF.
COUNTERMEASURES	Check the GAME TEST MODE settings.

DISPLAY	Error 8103 ALL.Net System error (TIMEOUT)
CAUSE	A connection could not be established with ALL.Net.
COUNTERMEASURES	Check the RINGWIDE network connection, the in-store network connection and the connection between the ALL.Net router and the network cable, and then follow the startup procedures to restart the system. If the error persists, check the maintenance information.
DISPLAY	Error 8104 ALL.Net System error (REG)
CAUSE	ALL.Net registration could not be confirmed.
COUNTERMEASURES	Check to make sure ALL.Net registration (the agreement) has been successfully completed.
DISPLAY	Error 8106 ALL.Net System Caution
CAUSE	A connection could not be established with ALL.Net.
COUNTERMEASURES	Check the RINGWIDE network connection, the in-store network connection and the connection between the ALL.Net router and network cable, and then follow the startup procedures to restart the system. If the error persists, check the maintenance information.
DISPLAY	Error 8111 ALL.Net System error (REG)
CAUSE	ALL.Net registration could not be confirmed.
COUNTERMEASURES	Check to make sure ALL.Net registration (the agreement) has been successfully completed.
DISPLAY	Error 8113 ALL.Net System error (MODE)
CAUSE	The ALL.Net settings could not be confirmed.
COUNTERMEASURES	Contact the office listed in this manual.
DISPLAY	Error 8114 ALL.Net System error (RTC)
CAUSE	A connection could not be established with ALL.Net.
COUNTERMEASURES	Check the RINGWIDE network connection, the in-store network connection and the connection between the ALL.Net router and the network cable, and then follow the startup procedures to restart the system. If the error persists, check the maintenance information.
DISPLAY	Error 8201 ALL.Net System error (TIMEOUT)
CAUSE	A connection could not be established with ALL.Net.
COUNTERMEASURES	Check the RINGWIDE network connection, the in-store network connection and the connection between the ALL.Net router and network cable, and then follow the startup procedures to restart the system. If the error persists, check the maintenance information.

DISPLAY	Error 8202 ALL.Net System error (REG)
CAUSE	ALL.Net registration could not be confirmed.
COUNTERMEASURES	Check to make sure ALL.Net registration (the agreement) has been successfully completed.
DISPLAY	Error 8301 Network error (GAME-LAN)
CAUSE	The connection with the devices that make up this game could not be confirmed.
COUNTERMEASURES	Check the network connection and follow the startup procedures to restart the system.
DISPLAY	Error 8302 Maintenance time (GAME)
CAUSE	Currently the server is undergoing maintenance.
COUNTERMEASURES	Wait until server maintenance is complete.
DISPLAY	Error 8303 Network error (GAME)
CAUSE	A connection could not be established with ALL.Net.
COUNTERMEASURES	Check the RINGWIDE network connection, the in-store network connection and the connection between the ALL.Net router and the network cable, and then follow the startup procedures to restart the system. If the error persists, check the maintenance information.
DISPLAY	Error 8304 Network failed (GAME)
CAUSE	Automatic recovery from the network failure is not possible.
COUNTERMEASURES	Check the RINGWIDE network connection, the in-store network connection and the connection between the ALL.Net router and the network cable, and then follow the startup procedures to restart the system. If the error persists, check the maintenance information.

Other ERROR codes.

DISPLAY	Error 1000 Force Feedback Error
CAUSE	Failed to initialise motor controller during power on cycle.
COUNTERMEASURES	Check all connection to and from Motor Controller. Possible failure of Motor Controller PCB. Replace and restart.
DISPLAY	<TICKET ERROR> PLEASE CONTACT OPERATOR
CAUSE	Ticket has jammed or tickets are empty.
COUNTERMEASURES	Clear ticket jam. Refloat with new tickets. Note: When resetting the error message, please take note of the number of tickets owed to the player as this number of tickets cannot be recalled.
DISPLAY	,<NETWORK FAILURE> PLEASE CONTACT OPERATOR
CAUSE	Communication failure across the network.
COUNTERMEASURES	Check all network cables for damage. Check all network connections to Hub. Check Hub for power. Possible Hub failure.
DISPLAY	<NETWORK FAILURE> <CABINET ID CONFLICT> PLEASE CONTACT OPERATOR
CAUSE	Incorrect values given to individual cabinets across the network.
COUNTERMEASURES	See chapter 9-3-4 on setting cabinet identifications

Manual Recovery

Use the following procedure to return the RINGWIDE system software to a previous state.

1

Press the TEST and SERVICE Buttons simultaneously with the RINGWIDE power off.
Hold the buttons down and turn on the power.

2

After RINGWIDE starts up and the following message is displayed, release the buttons.
The system software will recover automatically. The Advertising screen will be displayed once everything finishes.
Until it is displayed, do not interfere with the cabinet's operations.
(If you are uninstalling a game, the Install Wait screen will be displayed.)

SYSTEM UPDATE

STEP1

DO NOT TURN OFF THE POWER

11-5 REPLACING THE BUTTON BATTERY

WARNING

- Make sure you do not damage the printed board and wires. Such damage can lead to electric shock, short circuit and fire hazard.
- To prevent overheating, explosion, or fire:
 - Do not recharge, disassemble, heat, incinerate, or short the battery.
 - Do not allow the battery to come into direct contact with metallic objects or other batteries.
 - To preserve the battery, wrap it in tape or other insulating material.
- Follow local regulations when disposing of the battery. Improper disposal can damage the environment.
- Even the site maintenance personnel or other qualified professionals must not perform replacement operations for parts not described in this manual. In the event that such work is required either contact the office listed in this manual or first confirm the procedure with the place or office of purchase. Failure to do so may lead to electric shock or short circuit.
- Do not turn on the power with current carrying parts exposed. Doing so could result in electric shock or short circuit.

CAUTION

To avoid risk of malfunction and damage:

- Make sure the positive and negative ends are aligned correctly.
- Use only batteries approved for use with this unit.

IMPORTANT

- The batteries in RINGWIDE can be used for approximately 4 years of standard usage. If the battery appears to require replacement sooner than 4 years it is more likely that an error has occurred with some other part of the board. Rather than exchanging the battery requesting repair of the board itself may be more appropriate.
- Static electricity from your body may damage some electronics devices on the IC board. Before handling the IC board, touch a grounded metallic surface so that the static electricity can be discharged.

The button battery that require replacement can be found on the main board, inside the RINGWIDE shield case.

-
- 1** Remove the unit on which RINGWIDE is placed from the game cabinet. RINGWIDE must be removed still attached to the base (wooden shelf, etc.).

 - 2** Remove 2 screws for the RINGWIDE lid. The screws are on top of the connector side.

 - 3** Slide the lid toward the side with the connectors, and remove it.

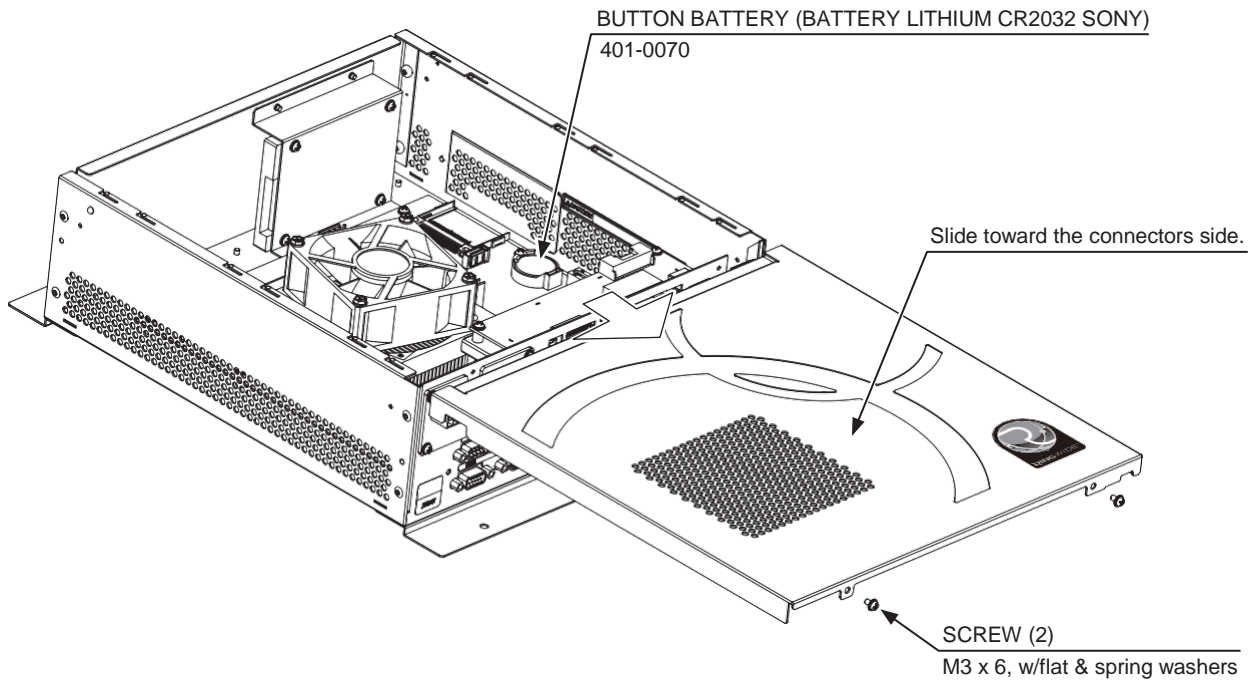

-
- 4** The main board is the board on the bottom of the RINGWIDE shield case. After replacing the main board's button battery, refer to Step 3 and close the lid.

11-6 CLEANING RINGWIDE

STOP IMPORTANT

- Clean RINGWIDE once a year or whenever either "Error 0090" or "Error 0091" occurs. Dust accumulating in game boards may not function properly.
- Set each cabinet to correct settings after cleaning the product. Be sure to set RINGWIDE to correct settings when returning. If the proper settings are not used, the units may not function properly.

Once a year remove RINGWIDE from the cabinet and use a vacuum cleaner to clean around the RINGWIDE's air vents and installation area.

1 Refer to the manual included with the game machine, and remove RINGWIDE from the cabinet.

2 Clean around the intake/exhaust vents of RINGWIDE with a vacuum cleaner.

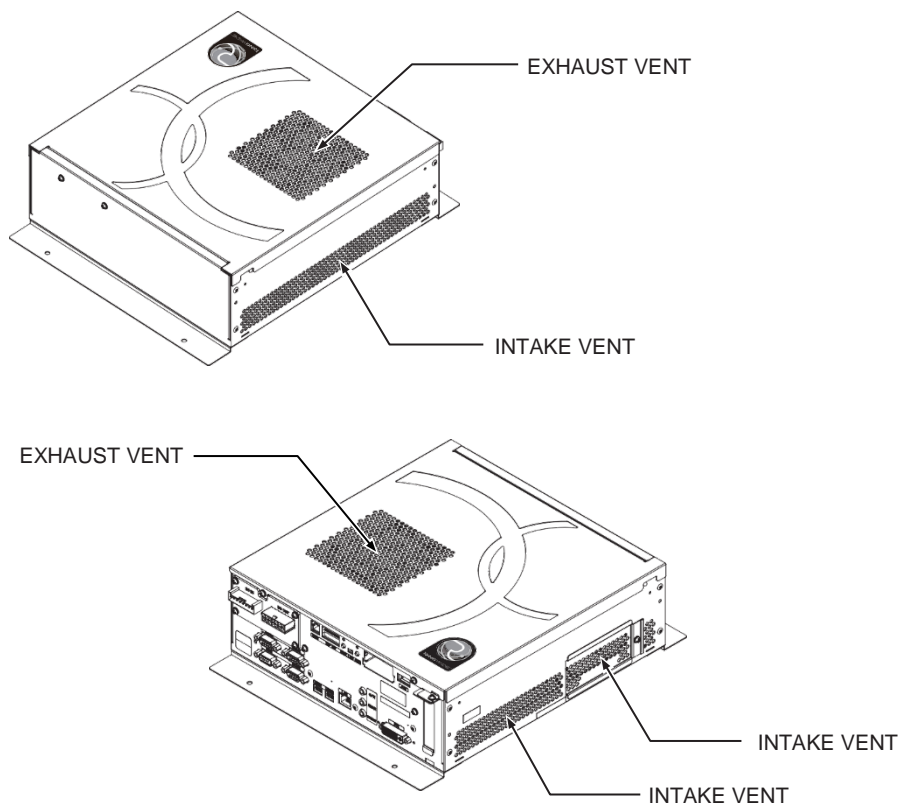

3 Clean around installment parts of RINGWIDE in the cabinet with a vacuum cleaner. Be sure not to damage wirings and boards. Electronic devices on boards may damage by static electricity, and be sure not to vacuum electronic devices by a vacuum cleaner.

4 Set each RINGWIDE you removed by the reverse method.

12 DESIGN-RELATED PARTS

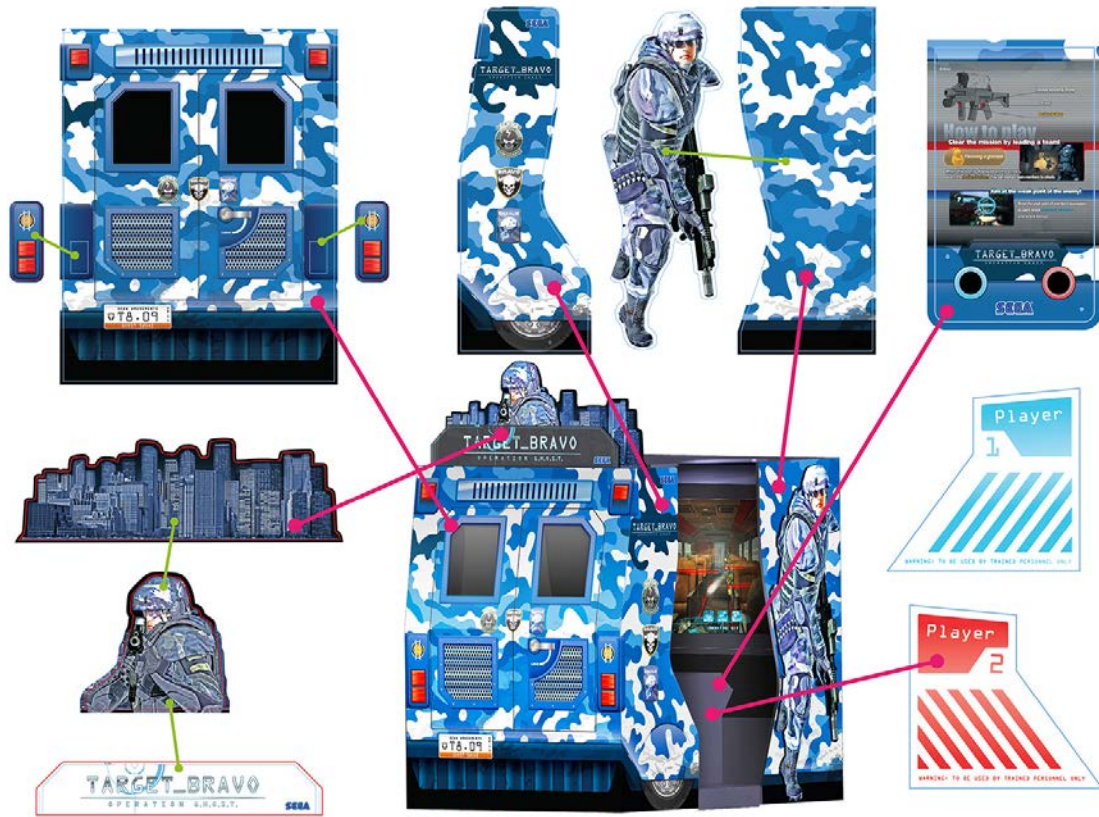

Level	Seq	Ref	Component code	Description	Units
	001	31	TB-00001-01UK	TARGET BRAVO CAB	1EA
	002	31	TB-UK	TARGET BRAVO UK PART	1EA
	002	31	838-14551-02UK	DISTRIBUTION BOARD	1EA
	003	31	838-14548-01UK	SW & C VOL BD IN POT	1EA
	004	31	EP1380-01	CREDIT BOARD EXCEL	1EA
	005	31	838-0026UK	AMP 2.1 40W KEENE	1EA
	006	31	LMA-7142UK	LED FILTER PLATE	10EA
	007	31	838-0031UK	LED DRIVER ATMEGA328	1EA
	008	31	843-0001-TB-UK	ASSY SOFTWARE TB01	1EA
	001	31	EP1486	ATMEGA328P W/FLY IC	1EA
	002	31	LB1186	LABEL W/FLY TB01	1EA
	009	31	390-2312-RGB-AD	LED FLX RGB S-AD	1.00MT
	007	31	TB-USA	TARGET BRAVO USA PAR	1EA
	007	31	400-050-012-01	PSU 12VDC 50W MW LPS	1EA
	008	31	400-075-024-01	PSU 24VDC 75W MW LPS	1EA
	009	31	400-075-005-01	PSU 5VDC 75W MW LPS-	1EA
	010	31	400-100-012-01	PSU 12V 100W MW LPS-	1EA
	011	31	200-6055-MV	LCD 55" MT55W-887A3-	1EA
	012	31	400-5483	SE REGU EADP-130CF A	1EA
	013	31	847-0001D	ASSY CASE WDE W 1GB	1EA
	014	31	GST-60101UK	WH AC IN	1EA
	015	31	GST-60102UK	WH AC DIST	1EA
	016	31	GST-60103UK	WH AC TO MONITOR	1EA
	017	31	GST-60104UK	WH DC IN RINGWIDE	1EA
	018	31	GST-60105UK	WH DC DIST	1EA
	019	31	GST-60106UK	WH DC OUT RINGWIDE	1EA
	020	31	GST-60107UK	WH SERIAL GAMEBOARD	1EA
	021	31	GST-60108UK	WH DC FANS	1EA
	022	31	GST-60109UK	WH I/O	1EA
	023	31	GST-60110UK	WH DC DIST B	1EA
	024	31	GST-60111UK	WH SPEAKERS	1EA
	025	31	GST-60112UK	WH GUNS	2EA
	026	31	GST-60113UK	WH LED SENSOR OUT	1EA
	027	31	GST-60115UK	WH BUTTONS	1EA
	028	31	GST-60117UK	WH REAR CAB	1EA
	029	31	GST-60118UK	WH REAR CAB BILLBOAR	1EA
	030	31	GST-60119UK	WH WOOFER	1EA
	031	31	GST-60120UK	WH COIN TOWER EXTN	1EA
	032	31	GST-60121UK	WH COIN HANDLING	1EA
	033	31	GST-60122UK	WH LED SIG & PWR	1EA
	034	31	GST-60125UK	WH LED DRV LINK	2EA
	035	31	GST-60126UK	WH CNTRL TO LED LWR	2EA
	036	31	GST-60127UK	WH LED FEATURE A	8EA
	037	31	GST-60128UK	WH LED FEATURE B	2EA
	038	31	GST-60129UK	WH LED FEATURE C	2EA
	039	31	GST-60130UK	WH CAB TO FLOOR	1EA

040	31 GST-60131UK	WH MASK LONG	2EA
041	31 GST-60132UK	WH MASK SHORT	7EA
04	31 GST-60134UK	WH SIDE PANEL LIGHTI	1EA
044	31 BE-60028UK	WH RIGID LED	10EA
045	31 GST-60135UK	WH SERIAL LED	2EA
04	31 GST-60136UK	WH ARTWORK LED	2EA
047	31 GST-60139UK	WH SIDE LIGHTING	1EA
048	31 GST-60137UK	WH 12V LINK	1EA
049	31 GST-60138UK	WH SENSOR EXTN	1EA
014	31 TB-SOJ	TARGET BRAVO SOJ PAR	1EA
014	31 837-14572	I/O CONTROL BD 3 FOR	1EA
015	31 838-15119-91	LED BD HFN G.SENSE G	10EA
016	31 GST-2100-01	CONTROL UNIT W/SUPPO	2EA
017	31 839-1243R	FUSE BD CTF	1EA
018	31 838-14988	SCH 30W AUDIO AMP ST	1EA
019	31 839-1383	CLASS D 10W STEREO A	1EA
020	31 837-15093-01	IC BD LED DRVR CONT	2EA
021	31 837-15141-01	LED BD RGB X15 SPI G	8EA
022	31 837-15142-01	LED BD RGB X5 SPI GS	4EA
023	31 838-15118-92	IC BD G.SENSE HF	1EA
024	31 253-5644-098BE	KEY CHIP RGW TBOGST	1EA
025	31 DVR-0086	RGW DVDROM TBOGST	1EA

ASSY CONTROLLER (GST-2100)

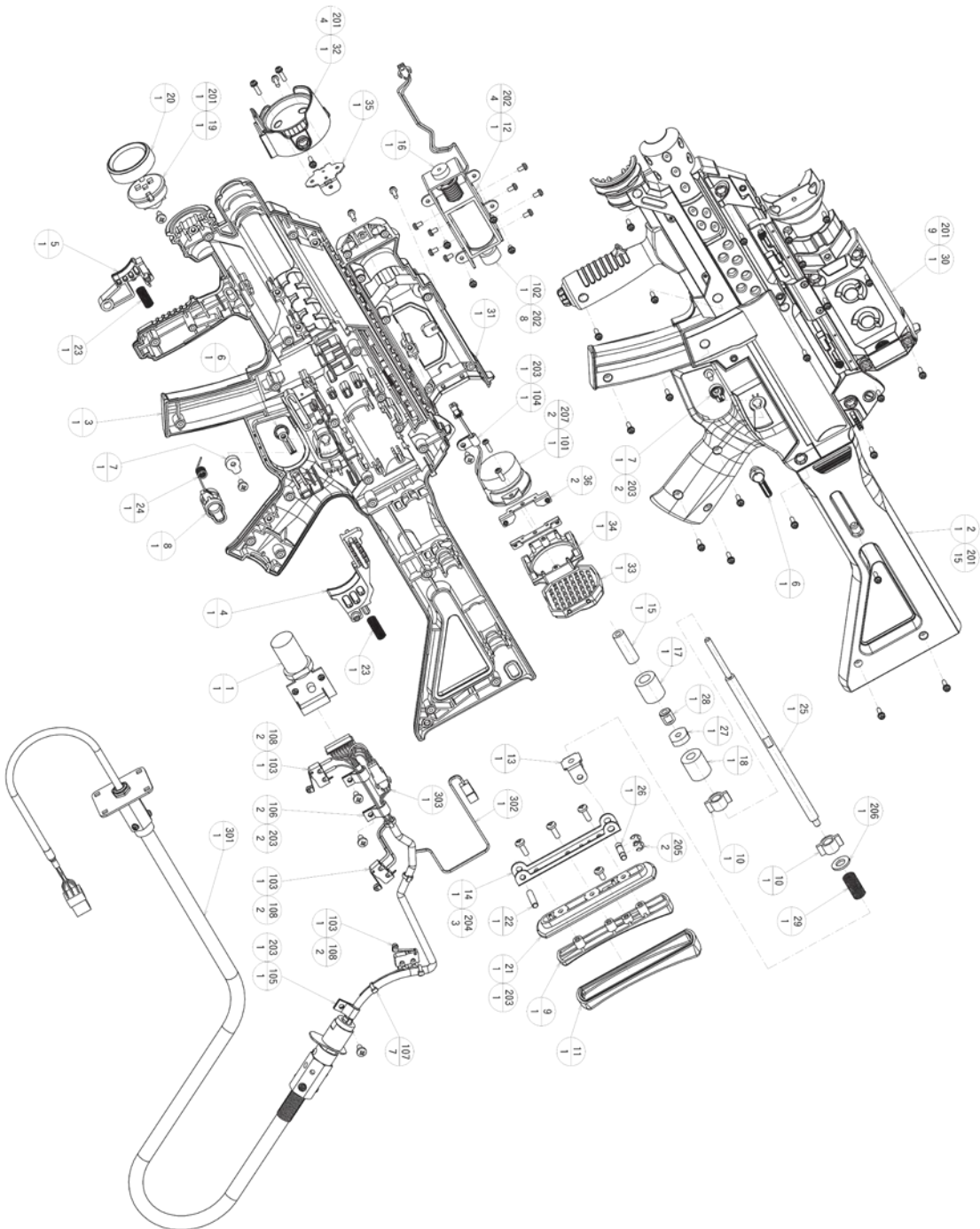

ASSY CONTROLLER (GST-2100)

(D-2/2)

ITEM NO	PART NUMBER	DESCRIPTION	QTY
1	GLG-2130X	SENSOR UNIT	1
2	GST-2101	COVER L	1
3	GST-2102	COVER R	1
4	GST-2104	MAIN TRIGGER	1
5	GST-2105	SUB TRIGGER	1
6	GST-2106	SELECTOR	2
7	CTF-2107	SELECTOR HOLDER	2
8	CTF-2108	SELECTOR JOINT	1
9	CTF-2009	PAD BASE	1
10	CTF-2110	BEARING HOLDER	2
11	CTF-2111	PAD	1
12	CTF-2112	SOLENIOD FRAME	1
13	CTF-2113	SHAFT JOINT	1
14	CTF-2114	PAD FRAME	1
15	CTF-2115	RECOIL DAMPER	1
16	CTF-2116	SOLENOID DAMPER	1
17	CTF-2117	SHAFT DAMPER F	1
18	CTF-2118	SHAFT DAMPER R	1
19	CTF-2119	CAP BASE	1
20	CTF-2120	LIGHT CAP	1
21	CTF-2121	PAD BEZEL	1
22	CTF-2122	PAD PIN	1
23	CTF-2123	TRIGGER SPRING	2
24	CTF-2124	SELECTOR SPRING	1
25	CTF-2125	SHAFT	1
26	CTF-2126	JOINT PIN	1
27	CTF-2127	SHAFT STOPPER	1
28	CTF-2128	DAMPER BASE	1
29	CTF-2129	RETURN SPRING	1
30	CTF-2130	SCOPE BODY L	1
31	CTF-2131	SCOPE BODY R	1
32	CTF-2132	LENS CAP	1
33	CTF-2133	SPEAKER NET	1
34	CTF-2134	BAFFLE	1
35	CTF-2135	BRKT LENS CAP	1
36	CTF-2136	BRKT BAFFLE	2
101	130-5288	SPEAKER 8OHM 5.5W	1
102	124-5113	SOLENOID DC24V THERMOSTAT	1
103	509-5080	SW MICRO TYPE (SS-5GL2)	2
104	280-5124-03	NYLON CLAMP NK03	1
105	280-5124-04	NYLON CLAMP NK04	1
106	280-5124-05	NYLON CLAMP NK05	2
107	601-0460	PLASTIC TIE BELT 100MM	7
108	310-5029-D20	SUMITUBE F D 20MM	6
201	FAS-000100	M SCR PH W/SMALL FS BLK M3X12	28
202	000-P00306-S	M SCR PH W/S M3X6	12
203	FAS-120029	TAP SCR P-TITE PH 4X8	8
204	FAS-120030	TAP SCR P-TITE PH BLK 4X12	3
205	065-E00400	E-RING 4MM	2
206	FAS-600020	FLT WSHR NORM A M8	1
207	FAS-120062	TAP SCR P-TITE PH 3X10	2
301	GST-60121	WH CONTROLLER W/SPEAKER	1
302	GST-60122	WH CONTROLLER SPEAKER	1
303	GST-60033	WH CONTROLLER SW EXT	1

13 WIRE COLOUR CODE TABLE

⚠ WARNING

The DC power wire color for this product is different from previous SEGA titles. Working from the previous wire colors will create a high risk of fire.

The color codes for the wires used in the diagrams in the following chapter are as follows.

A	PINK
B	SKY BLUE
C	BROWN
D	PURPLE
E	LIGHT GREEN

Wires other than those of any of the above 5 single colors will be displayed by 2 alphanumeric characters.

1	RED
2	BLUE
3	YELLOW
4	GREEN
5	WHITE
7	ORANGE
8	BLACK
9	GRAY

If the right-hand side numeral of the code is 0, then the wire will be of a single color shown by the left-hand side numeral (see the above).

Note 1: If the right-hand side numeral is not 0, that particular wire has a spiral color code. The left-hand side character shows the base color and the right-hand side one, the spiral color.

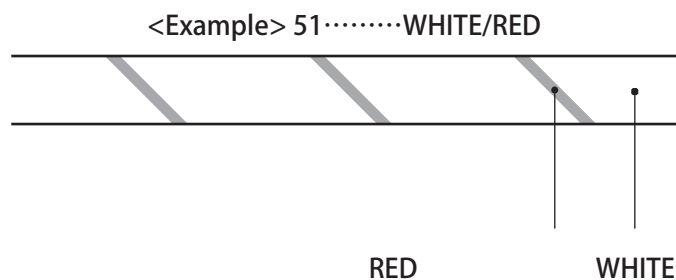

Note 2: The character following the wire color code indicates the size of the wire.

U:	AWG16
K:	AWG18
L:	AWG20
None:	AWG22

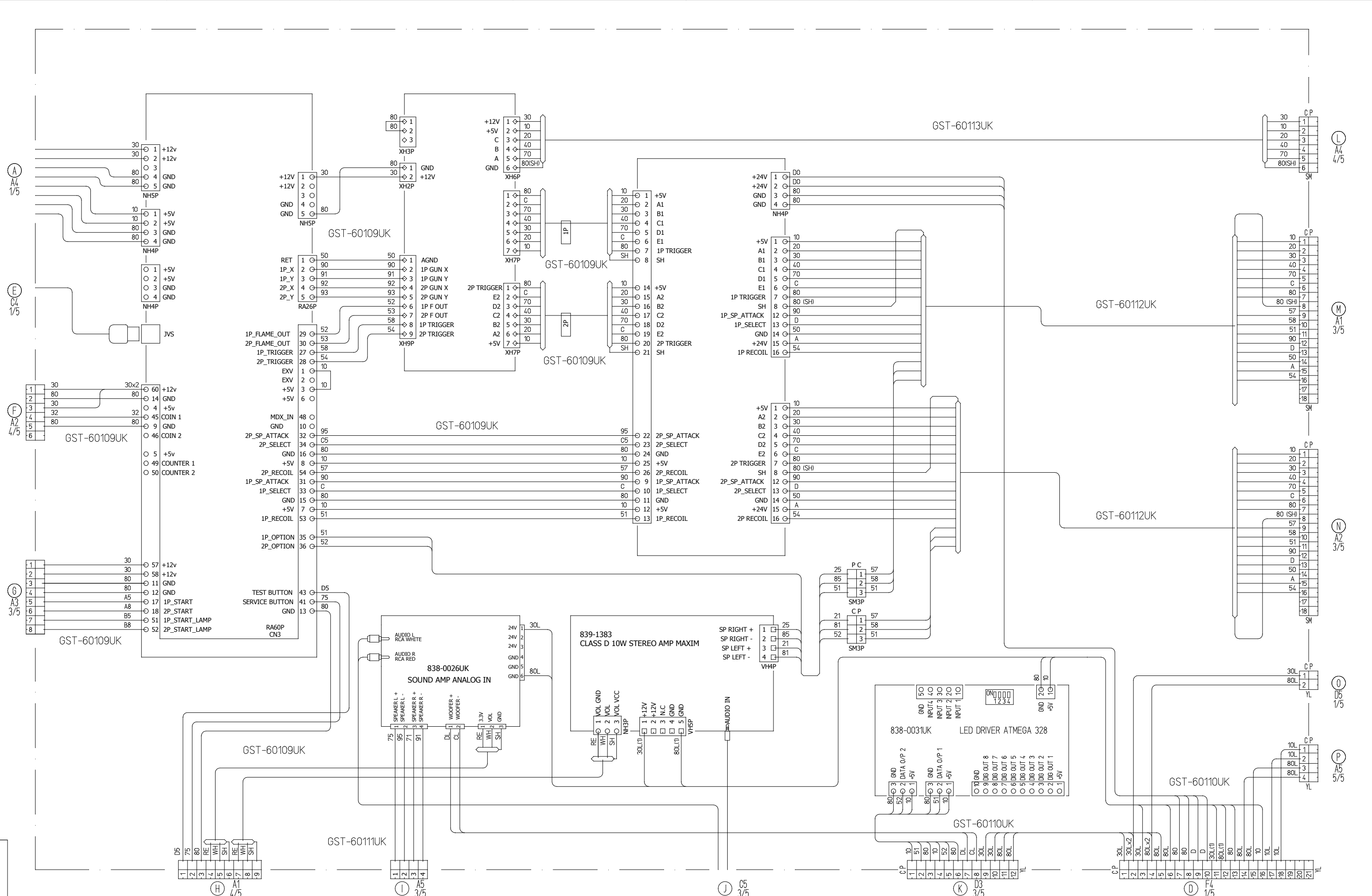

ALTERATIONS		COLOUR CODE		WIRE TYPE		DRAWN	CHKD	D/CHKD	APPR	SEGA AMUSEMENTS EUROPE, LTD. TARGET BRAVO	THIS DRAWING WILL IN NO WAY BE COPIED. TO BE RETURNED ON DEMAND.	ORIGINAL SIZE A3 PAGE 2 of 5	PART NO.
1	2	3	4	5	7	RA							
1	2	3	4	5	7								

M
H2
2/5

N
H3
2/5

O
A4
2/5

P
O5
2/5

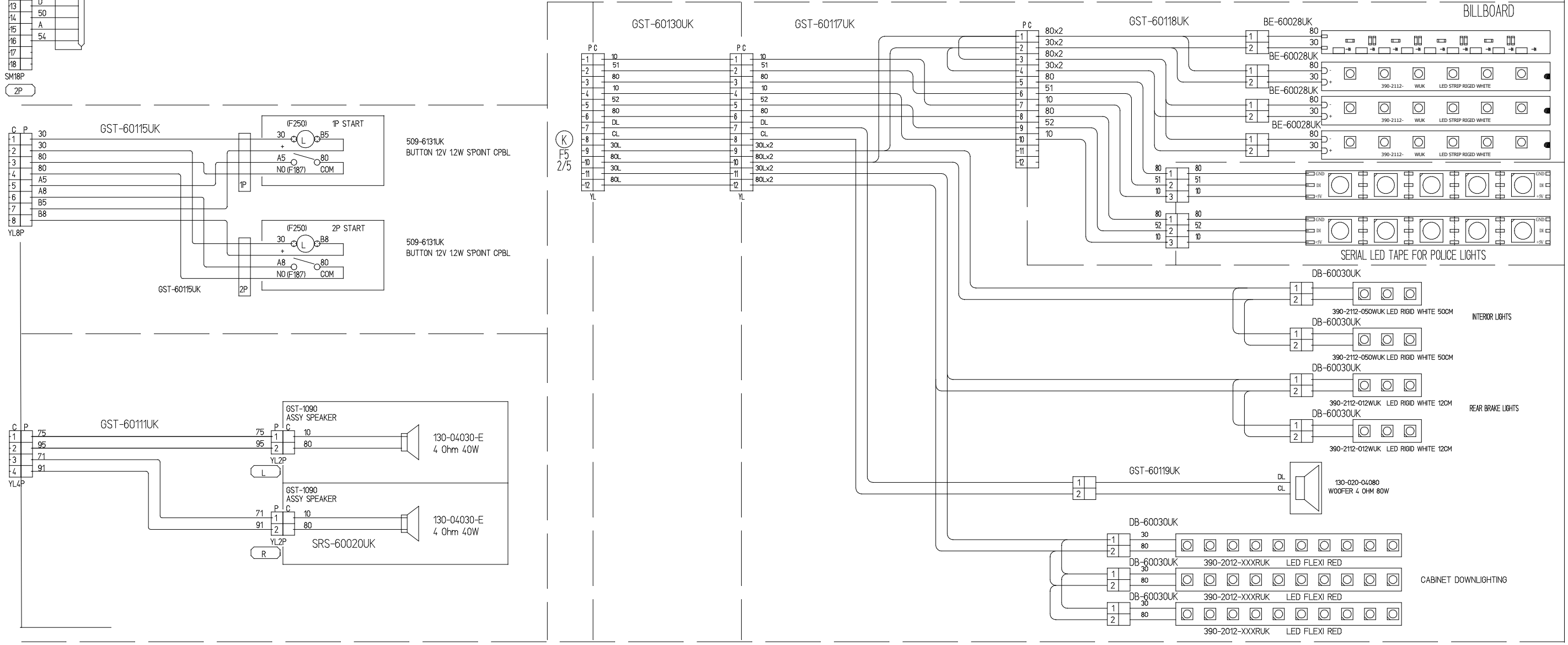
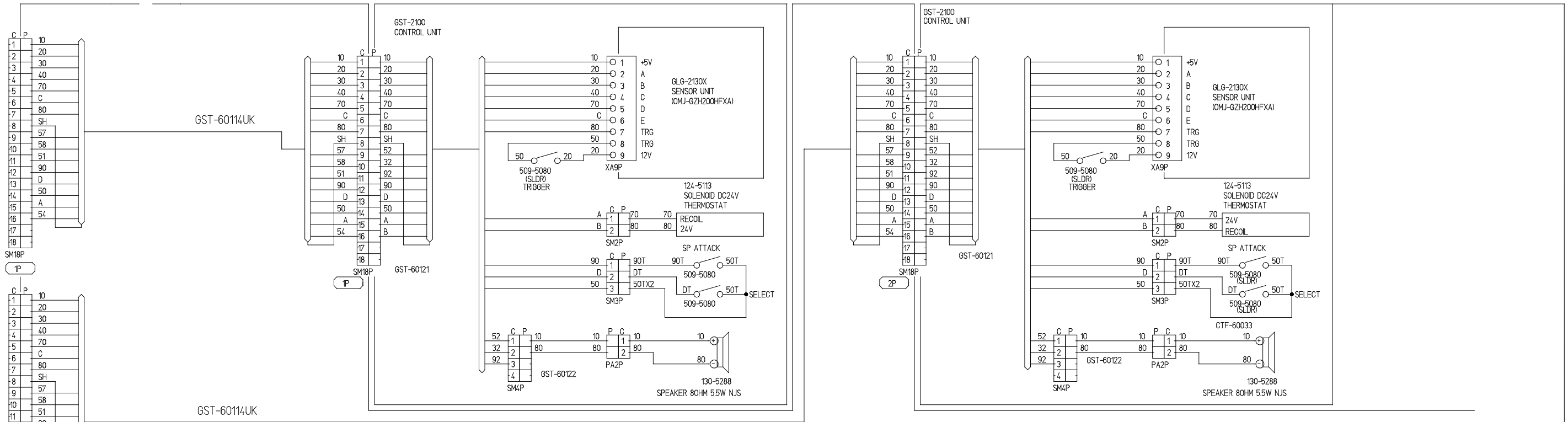

1	RED	8	BLACK	E	LIGHT GREEN
2	BLUE	9	GREY		
3	YELLOW	A	PINK		
4	GREEN	B	SKY BLUE	U	AWG 16 UL1015
5	WHITE	C	BROWN	K	AWG 18 UL1015
7	ORANGE	D	PURPLE	L	AWG 20 UL1007
					AWG 22 UL1007

DRAWN	CHKD	D/CHKD	APPR
RA			



SEGA AMUSEMENTS EUROPE, LTD.

TARGET BRAVO

THIS DRAWING WILL IN NO WAY BE COPIED.
TO BE RETURNED ON DEMAND.

ORIGINAL SIZE
A3

PAGE 3 of 5

DESCRIPTION

PART NO.

ALTERATIONS

CLOUR CODE

WIRE TYPE

A B C D E F G H

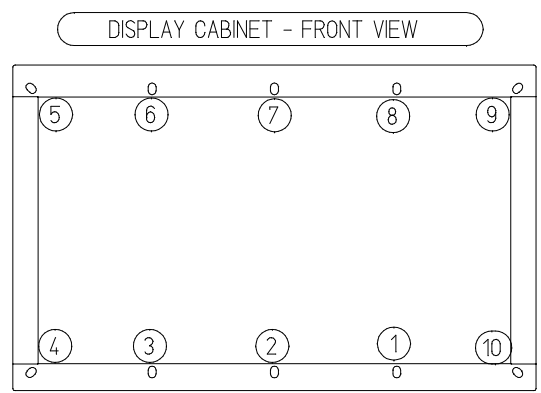
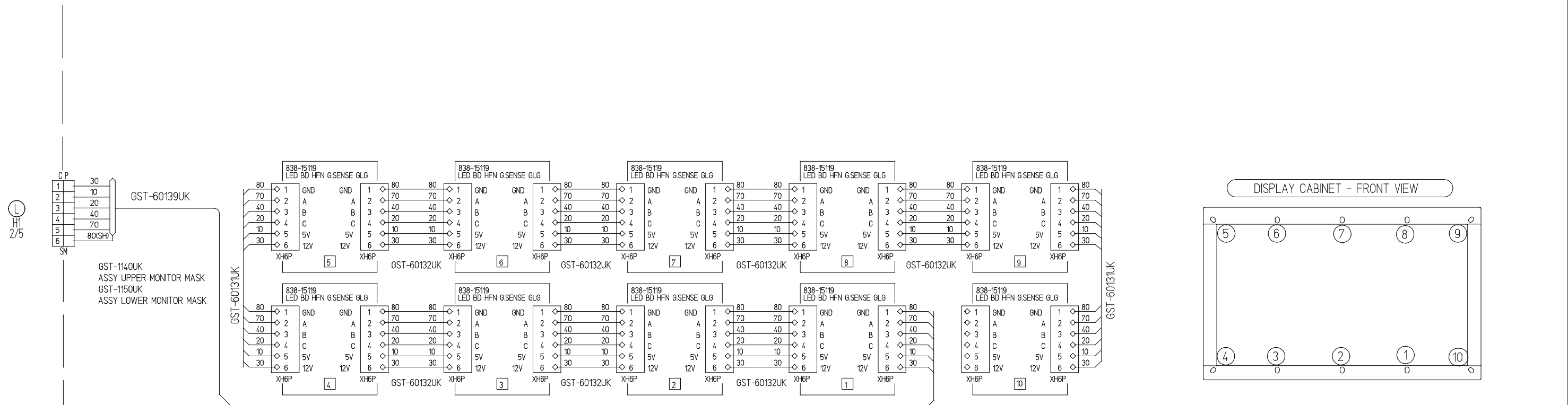
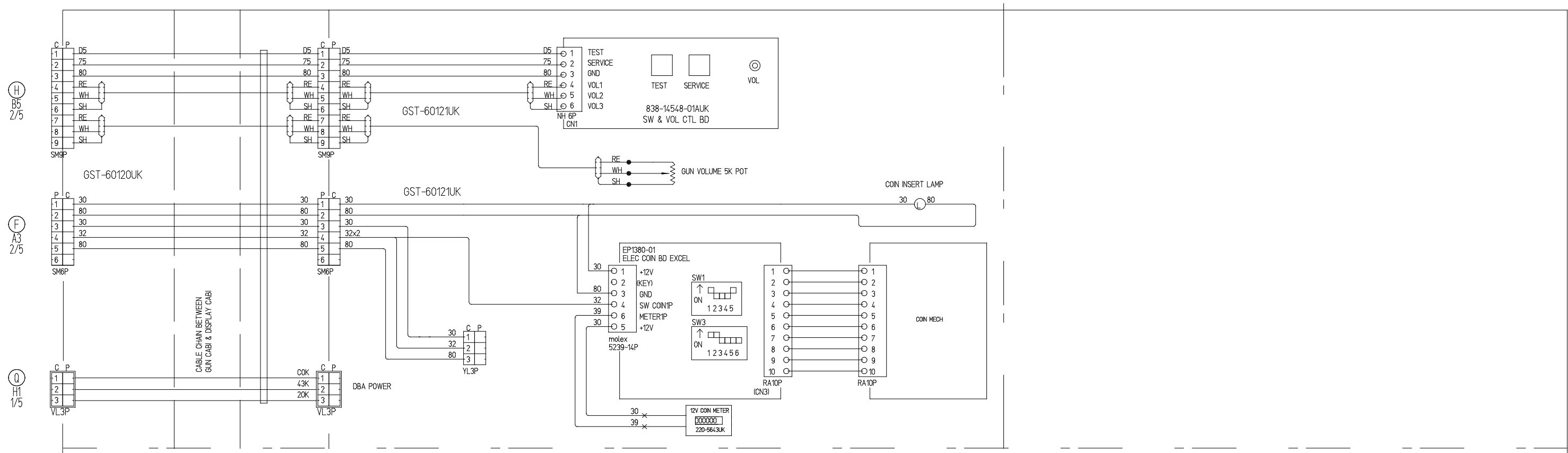

1	RED	8	BLACK	E	LIGHT GREEN
2	BLUE	9	GREY		
3	YELLOW	A	PINK		
4	GREEN	B	SKY BLUE		
5	WHITE	C	BROWN		
7	ORANGE	D	PURPLE		

DRAWN	CHKD	D/CHKD	APPR
RA			



SEGA AMUSEMENTS EUROPE, LTD.

TARGET BRAVO

THIS DRAWING WILL IN NO WAY BE COPIED.
TO BE RETURNED ON DEMAND.

ORIGINAL SIZE
A3

PAGE 4 of 5

ALTERATIONS

COLOUR CODE

WIRE TYPE

DESCRIPTION

PART NO.

