



**UNIVERSITÀ  
DI FOGGIA**



HR EXCELLENCE IN RESEARCH

---

PH.D.

“HEALTHY FOODS: INNOVATION AND MANAGEMENT”

(XXX CYCLE)

# **SUSTAINABILITY AND INNOVATION OF THE SWEET CHERRY SUPPLY CHAIN**

Ph.D. candidate:

Angela Mariuccia Andriano

Tutor:

Prof. Caterina Tricase

Academic Year: 2016/2017

## CONTENTS

ABSTRACT.....	1
INTRODUCTION .....	3
PRINCIPAL CHARACTERISTICS OF THE SWEET CHERRY .....	6
1.1 Background information .....	6
1.2 Sweet cherry processing: technologies and innovations.....	21
1.3 Innovative technologies in the sweet cheery supply chain .....	28
1.4 Sweet cherry’s market: economic aspects .....	36
SUSTAINABILITY OF THE SWEET CHERRY SUPPLY CHAIN: A CASE STUDY .....	44
2.1 Carbon Footprint: principal aspects of ISO/TS 14067:2013 .....	45
2.2 Sweet cherry supply chain: from nursery to processing phases.....	52
2.3 Material and methods.....	55
2.3.1 Goal and scope .....	59
2.3.2 Functional Unit and system boundary.....	60
2.3.3 Life cycle inventory analysis.....	61
2.3.4 Methane and nitrous oxide from manure management .....	70
2.3.5 Nitrous oxide and carbon dioxide from soil management .....	72
2.3.6 GHG emissions from orchard management and transport of materials and workers .....	76
2.3.7 Processing phase.....	80
2.4 Results and discussion .....	81
CONCLUSIONS.....	100
REFERENCES.....	102
APPENDIX.....	119
Carbon Footprint of each treatment and phase in system boundaries.....	119
List of symbols and abbreviations .....	159

## LIST OF FIGURES

Figure 1: Distribution of sweet cherry (striped area), sour cherry (solid line), and ground cherry (broken line).....	6
Figure 2: Sweet cherry ( <i>Prunus Avium</i> ).....	9
Figure 3: Form and skin colour of cherry .....	10
Figure 4: Bioactive Food Components in Sweet Cherries .....	21
Figure 5 Horizontal flow-pack wrapping.....	24
Figure 6: Principal sweet cherry processing (personal elaboration) .....	27
Figure 7: Alternative uses of the sweet cherries. ....	29
Figure 8: Importing countries of Italy.....	39
Figure 9: World production of cherries (values in kt) .....	41
Figure 10: Production of cherries in Italian region in 2015 .....	42
Figure 11: Overview of GHG Protocol scopes and emissions .....	48
Figure 12: Cherry orchard life-cycle phases (after three-year tree planting).....	53
Figure 13: System boundaries of sweet cherries supply chain investigated .....	54
Figure 14: Boundaries of cherry orchard system investigated.....	58
Figure 15: Transport flow and related fuel consumption associated with the materials and workers involved in each phase of the orchard life-cycle.....	78
Figure 16: Sankey diagram (kgCO <sub>2eq</sub> ) - (FU: 0.5 kg of fresh sweet cherry packed in PET clamshell) .....	82
Figure 17: Sankey diagram (%) – (FU: 0.5 kg of fresh sweet cherry packed in PET clamshell).....	83
Figure 18: GHG emission from each agricultural phase (kgCO <sub>2</sub> ) .....	85
Figure 19: Sankey diagram (kgCO <sub>2eq</sub> ) - (FU: 1 ha sweet cherry orchard).....	89
Figure 20: Sankey diagram (%) - (FU: 1 ha sweet cherry orchard).....	90
Figure 21: Sankey diagram (kg CO <sub>2eq</sub> ) - (FU: 1 kg sweet cherry processed).....	92
Figure 22: Sankey diagram (%) - (FU: 1 kg sweet cherry processed) .....	93
Figure 23: System boundaries of PET clamshell production.....	95
Figure 24: Sankey diagram (kgCO <sub>2eq</sub> ) - (FU: 1 kg PET clamshell) .....	96
Figure 25: Sankey diagram (%) - (FU: 1 kg PET clamshell).....	97
Figure 26: contributing GHGs (FU: 0.5 kg of cherry packed in PET clamshell).....	98
Figure 27: Sankey diagram (kgCO <sub>2eq</sub> ) of ploughing- (FU: 1 plant of sweet cherry).....	119
Figure 28: Sankey diagram (%) of ploughing- (FU: 1 plant of sweet cherry).....	120

Figure 29: Sankey diagram (kgCO <sub>2eq</sub> ) of pruning- (FU: 1 plant of sweet cherry) .....	121
Figure 30: Sankey diagram (%) of pruning- (FU: 1 plant of sweet cherry).....	122
Figure 31: Sankey diagram (kgCO <sub>2eq</sub> ) of manure spreading- (FU: 1 plant of sweet cherry) .....	123
Figure 32: Sankey diagram (%) of manure spreading - (FU: 1 plant of sweet cherry) .....	124
Figure 33: Sankey diagram (kgCO <sub>2eq</sub> ) of nursery phase - (FU: 1 plant of sweet cherry).....	125
Figure 34: Sankey diagram (%) of nursery phase - (FU: 1 plant of sweet cherry).....	126
Figure 35: Most contribution of GHGs (%) in nursery phase (FU: 1 plant of sweet cherry).....	127
Figure 36: Sankey diagram (kgCO <sub>2eq</sub> ) of I Phase - (FU: 1 ha sweet cherry orchard).....	128
Figure 37: Sankey diagram (%) of I Phase - (FU: 1 ha sweet cherry orchard).....	129
Figure 38: Most contribution of GHGs (kgCO <sub>2eq</sub> ) in I Phase - (FU: 1 ha sweet cherry orchard) ...	130
Figure 39: Most contribution of GHGs (%) in I Phase - (FU: 1 ha sweet cherry orchard) .....	131
Figure 40: Sankey diagram (kgCO <sub>2eq</sub> ) of II Phase - (FU: 1 ha sweet cherry orchard) .....	132
Figure 41: Sankey diagram (%) of II Phase - (FU: 1 ha sweet cherry orchard) .....	133
Figure 42: Sankey diagram (kgCO <sub>2eq</sub> ) of II Phase - (FU: 1 ha sweet cherry orchard) .....	134
Figure 43: Sankey diagram (%) of Full Production Phase - (FU: 1 ha sweet cherry orchard).....	135
Figure 44: Most contribution of GHGs (kgCO <sub>2eq</sub> ) in Full Production Phase - (FU: 1 ha sweet cherry orchard) .....	136
Figure 45: Most contribution of GHGs (%) in Full Production Phase - (FU: 1 ha sweet cherry orchard).....	137
Figure 46: Sankey diagram (kgCO <sub>2eq</sub> ) of Pest Management treatment - (FU: 1 ha sweet cherry orchard).....	138
Figure 47: Sankey diagram (%) of Pest Management treatment - (FU: 1 ha sweet cherry orchard) .....	139
Figure 48: Sankey diagram (kgCO <sub>2eq</sub> ) of Pest Management treatment in Full Production Phase - (FU: 1 ha sweet cherry orchard) .....	140
Figure 49: Sankey diagram (%) of Pest Management treatment in Full Production Phase - (FU: 1 ha sweet cherry orchard).....	141
Figure 50: Sankey diagram (kgCO <sub>2eq</sub> ) of Fertilizer administration - (FU: 1 ha sweet cherry orchard) .....	142
Figure 51: Sankey diagram (%) of Fertilizer administration - (FU: 1 ha sweet cherry orchard).....	143
Figure 52: Most contribution of GHGs (kgCO <sub>2eq</sub> ) in Fertilizer treatment (FU: 1 ha sweet cherry orchard).....	144

Figure 53: Sankey diagram (kgCO <sub>2eq</sub> ) of cherry agriculture management with manure - (FU: 1 ha sweet cherry orchard).....	145
Figure 54: Sankey diagram (%) of cherry agriculture management with manure - (FU: 1 ha sweet cherry orchard).....	146
Figure 55: Most contribution of GHGs (kgCO <sub>2eq</sub> ) in cherry agriculture management with manure - (FU: 1 ha sweet cherry orchard) .....	147
Figure 56: Most contribution of GHGs (%) in cherry agriculture management with manure - (FU: 1 ha sweet cherry orchard).....	148
Figure 57: Sankey diagram (kgCO <sub>2eq</sub> ) of Processed Cherry Phase- (FU: 1 kg processed cherry) ..	149
Figure 58: Sankey diagram (%) of Processed Cherry Phase - (FU: 1 ha sweet cherry orchard).....	150
Figure 59: Sankey diagram (kgCO <sub>2eq</sub> ) of PET clamshell Production- (FU: 1 kg PET clamshell) ..	151
Figure 60: Sankey diagram (%) of PET clamshell Production - (FU: 1 kg PET clamshell) .....	152
Figure 61: Most contribution of GHGs (kgCO <sub>2eq</sub> ) in PET clamshell Production Phase (FU: 1 kg PET clamshell).....	153
Figure 62: Most contribution of GHGs (kgCO <sub>2eq</sub> ) in PET clamshell Production Phase (FU: 1 kg PET clamshell).....	154
Figure 63: Sankey diagram (kgCO <sub>2eq</sub> ) of cherries packed in PET clamshell - (FU: 0.5 kg of cherry packed in PET clamshell) .....	155
Figure 64: Sankey diagram (%) of cherries packed in PET clamshell - (FU: 0.5 kg of cherry packed in PET clamshell).....	156
Figure 65: Most contribution of GHGs (kgCO <sub>2eq</sub> ) in cherries packed in PET clamshell Phase - (FU: 0.5 kg of cherry packed in PET clamshell).....	157
Figure 66: Most contribution of GHGs (kgCO <sub>2eq</sub> ) in cherries packed in PET clamshell Phase - (FU: 0.5 kg of cherry packed in PET clamshell).....	158

## LIST OF TABLES

Table 1: Classification report of sweet cherry .....	7
Table 2: Main sweet cherry cultivar .....	13
Table 3: Nutrient value for sweet cherry .....	18
Table 4: Components, origin and effect on products of edible coatings and films.....	34
Table 5: Cherries production and cultivated area in Apulia districts.....	43
Table 6: GWP <sub>100</sub> per kg emission (kg CO <sub>2eq</sub> /kg GHG) .....	46
Table 7: Kyoto Protocol GHGs and GWP100 values.....	56
Table 8: Functional units considered for the CF of sweet cherry .....	61
Table 9: Input inventory-data related to Nursery phase.....	63
Table 10: Input inventory-data related to I phase (I-III).....	64
Table 11: Input inventory-data related to II phase (IV-VI) .....	65
Table 12: Input inventory-data related to Full Production phase (VII-XX) .....	67
Table 13: Input inventory-data related to Clamshell PET production .....	68
Table 14: Input inventory-data related to Processed Cherry.....	69
Table 15: Concentration of nitrogen in organic fertilizers.....	73
Table 16: Carbon balance of sweet cherry orchard (data are expressed in <i>kg DW C ha<sup>-1</sup>yr<sup>-1</sup></i> ).....	76
Table 17: Diesel consumption from agriculture management and transport of materials and workers based on the total cherries production.....	80
Table 18: Energy consumption kWh from processing phase considering the total cherry production 228 t.....	80
Table 19: Comparison of energy input ratio between the present study and Turkish research during the full production.....	88

## ABSTRACT

Sweet cherry (*Prunus avium* L.) is one of the most appreciated fruits worldwide thanks to the organoleptic characteristics (i.e. taste, sweetness and colour) as well as the natural presence of nutrients, antioxidants and other healthy compounds such as i.e. flavonoids, vitamins, anthocyanins and phenolic. Italy is the fourth top world cherries producer after Turkey, United States of America, and Iran (Islam Republic of). In particular, Apulia represents the first Italian cherry production region contributing in 2017 with 32% to the annual national production. Although this fruit is important worldwide, its sector has to face continuous challenges in different fields i.e. economic, environmental and social to remain competitive on the global market. For these reasons, it is needed to search solutions (for instance introducing innovation technologies) that improve productivity, profitability and sustainability according to agricultural European rules (i.e. Common Agricultural Policy – CAP 2014-2020) that promote the innovation/internationalization of enterprise through operational funds.

The research presents a case study of cherries supply chain managed by two firms situated in Apulia region (South Italy). The aim is to calculate GHG emissions of the sweet cherry, according to CF methodology based on Life Cycle Assessment (LCA) approach. The supply chain considered two phases: agriculture and processing. The former includes orchard management from nursery to harvesting and considering the entire orchard life cycle equal to 20 years; whereas the latter examines the processing of sweet cherries, from harvesting in the orchard to the collected centre where they are packaged for the fresh market. The study highlights that the  $GWP_{100}$  associated with the system investigated is equal to 0.798 kg  $CO_{2eq}$  per 0.5 kg of fresh sweet cherry packed in PET clamshell. In particular, the study shown that the impacts coming from the agricultural management stage is equal to 0.656 kg $CO_{2eq}$ , the processing is 0.068 kg $CO_{2eq}$  and clamshell PET production is 0.0744 kg $CO_{2eq}$ . As regard the orchard phase, the principal impact derives from the full production where the most  $GWP_{100}$  impact is represented by the utilisation of the groundwater pumping station (electricity, low voltage production) for the irrigation and fertigation activities (15.6% of the total  $CO_{2eq}$ ), by the transport of manure (4.7% of the total  $CO_{2eq}$ ) and by the ploughing (3.53% of the total  $CO_{2eq}$ ).

## Sustainability and innovation of the sweet cherry supply chain

These results could contribute to provide information to stakeholders involved in the sweet cherry supply chain to promote or enhance a sweet cherry production mainly environmental sustainable.

*Keywords:* sweet cherry, sustainability, Life Cycle Assessment, Carbon Footprint, agri-food sector, innovation.



## INTRODUCTION

Sweet cherry is one of the most appreciated fruits worldwide thanks to the organoleptic characteristics (i.e. taste, sweetness and colour) as well as the natural presence of nutrients, antioxidants and other healthy compounds such as i.e. flavonoids, vitamins, anthocyanins and phenolic. Italy is the fourth top world cherries producer after Turkey, United States of America, and Iran (Islam Republic of) (FAOSTAT, 2017). In particular, Apulia represents the first Italian cherry production region contributing in 2017 with 32% to the annual national production (Agri-ISTAT, 2017). Although this fruit is important worldwide, its sector has to face continuous challenges in different fields i.e. economic, environmental and social to remain competitive on the global market. For these reasons, it is needed to search solutions (using, for instance, innovation technologies) that improve productivity, profitability and efficiency use of resources in agro-ecosystems.

In last ten year, the increase of cherry production derived principally from high demand of consumer which is always more careful on health benefits of this fruit (Wani et al., 2014) due to the presence of some nutrients (Esti et al., 2002; Usenik, Kastelec, and Stampar, 2005; Gabriele et al., 2013). Indeed, thanks to the antioxidant compounds, such as phenols (Jakobek et al., 2007; Usenik, Fabčič and Štampar, 2008), anthocyanins and flavanols (Gonçalves et al., 2004) (Yoo et al., 2010), sweet cherries have neuroprotective effects (Kim et al., 2005) and cancer-preventive properties (Kang et al., 2003). Additionally, they reduce pain from inflammation and arthritis (Jacob et al., 2003; Mamani-Matsuda et al., 2006; Seeram et al., 2001) and the muscle damage symptoms caused by exercise (Connolly, McHugh and Padilla-Zakour, 2006); finally, they defence human body against oxidative stress (Tian et al., 2004) and neurodegenerative diseases (Kim et al., 2005; Usenik, Fabčič and Štampar, 2008).

To satisfy consumer demand and further increase of sweet cherry production, innovative solutions have proposed such as breeding programmes started in different country, among which Italy (Sansavini and Lugli, 2008). The aim of these programmes is to develop new sweet cherry cultivars able to expand the marketing calendar (Sansavini and Lugli 2005; Lang et al. 1998; Kappel et al., 1998) and to improve quality and performance of sweet cherry. In particular, these cultivars product trees with high-performance and fruit whit top-quality such as, for instance large size (Lapins 1974; Lane and Schmid 1984; Lang et al. 1998; Lang, 1999; Sansavini and Lugli 2005; Kappel et al. 2000a,b; Lang 2002 ), firm flesh (Sansavini and Lugli 2005; Kappel, 2005; Kappel and Lane 1998) and excellent shiny, red colour,

flavour and taste. Moreover, the high respiration rates make sweet cherry fruit highly perishable with a short shelf life. This aspect leads to quality loss of these fruits before reaching consumers. So, to prevent these losses during the harvesting and selling, sweet cherries have to be rapidly commercialised a low-price fruit (Aday and Caner, 2010). To overcome these hurdles, it has been proposed further product innovation represented by edible coating technology. It can contribute to preserve the quality of sweet cherries, to extend their shelf life and to make it more attractive for consumers (Mahfoudhi and Hamdi, 2015). Edible coatings can be based also on biopolymers principally deriving from agriculture by-products (e.g. polysaccharides, protein or lipids). In this way, thanks their characteristics, edible coating can: 1) increase the profitability and competitiveness of this sector on global level; 2) decrease the use of natural resources; 3) extend the fruit shelf life; 4) respond to consumer demand which requests ecological products with a low environmental impact. Furthermore, the innovation has improved not only the product but also the process such as, for instance, the agriculture phase where have been introduced a new layout which consist in mid and high-density planting system. These can decrease cherry cultivation costs, labours and orchard inputs and improve yield (Kappel et al, 2012; Sansavini and Lugli, 2008).

To satisfy the consumer request of sweet cherries sustainable production it is also fundamental considering some aspects such as natural resources consumption, water demand and greenhouse gas (GHG) emissions in atmosphere. Among environmental challenges, GHG release have top priority since they are responsible of Climate Change. Specifically, in the sweet cherry supply chain the agriculture production phase is the most impacting, (Gan et al. 2011; Dalgaard et al. 2001; Shepherd et al. 2003; Stolze et al. 2000) and the most GHG emissions derive from fertilizers and pesticides production and their administration, transport of workers, and farming activities (tillage, pruning, etc.). However, agriculture could have also a potential role for the climate change mitigation since biomass can represent a sink to store CO<sub>2</sub> under and above the soil (Kroodsma and Field 2006; OECD 2001; Shepherd et al. 2003; Smith et al., 2007). For these reasons, it is important to introduce sustainable agriculture practices that transform the orchard from carbon emission source to sink (IPCC, 2007).

In this context it is fundamental to assess the GHG emission coming from sweet cherry production. To assess this aspect, it can be used the Carbon Footprint (CF) that quantifies the GHG emission amount. It is a useful tool to identify the potential sources of these gasses and

to find appropriate improvement solutions. Although there are a wide and articulate literature about CF of agricultural products, there are few studies focused on sweet cherry supply chain (Demircan et al., 2006, Kizilaslan, 2009, Litskas et al., 2011, Bravo et al., 2017; Tricase et al., 2017).

In light of the above, the present study intends, first, to provide a framework of the sweet cherry supply chain. This section introduces the principal sweet cherry commodity-related aspects (origin, history, principal botanical, agronomic and nutritional aspects) and it makes an overview on new technologies able to preserve the quality, to reduce the environmental impact of sweet cherry supply chain and to extend the shelf life of this fruit.

Second, the research presents a case study of cherries supply chain, from nursery to processing phase, managed by two firms located in the Barletta-Andria-Trani (BAT) district, situated in Apulia region (South Italy). The aim is to calculate GHG emissions of the sweet cherry (*Prunus avium* L.), according to CF methodology (according to ISO/TS 14067:2013) based on Life Cycle Assessment (LCA) approach (ISO 14040:2006 and ISO 14044:2006). The supply chain considered in the present case study consists in two phases: agriculture and processing. The former includes orchard management from nursery to harvesting, whereas the latter considers the processing of sweet cherries, from harvesting in the orchard to the collected centre where they are packaged for the fresh market. In particular, the research uses data collected by some local farmers and agronomists and manager of the collected centre and assess the complete orchard life cycle (twenty years).

Thanks to the CF assessment of the case study in Apulia region, the research aims to create a basis for developing a specific product certification that takes into account also the sustainability. In fact, the corporate brand, if it is accompanied by this typology of certification, can be particularly useful in the current phase of the market globalization. At the same time, this assessment could represent a first step to implement a best practice for agriculture sector according to agricultural European rules (i.e. Common Agricultural Policy – CAP 2014-2020) that promote the innovation/internationalization of enterprise through operational funds (Andriano et al., 2015).

## PRINCIPAL CHARACTERISTICS OF THE SWEET CHERRY

### 1.1 Background information

Cherries originated in central Asia, close to the Caspian and Black Seas (Vavilov, 1951; Watkins, 1976). They spread slowly from that region mostly via birds (Jackson, 1986). Sweet cherry cultivation spread through Europe in times of the Roman Empire, although they were not planted extensively until the 16th century (Watkins, 1976). according to the scientist and Latin writer Pliny the cherry tree is was brought from Rome to Asia by the Roman general Lucullus after beating king of Pontus, Mitriades, in 65 DC. The Romans spread its culture throughout the Mediterranean. Moreover, Pliny and Virgil described the cherry cultivars of the Roman Empire, including the cultivar ‘Junian’ whose characteristics fit with those of the French ‘Guigne’ and the ancient cultivar ‘Lusitanina’ that corresponds to the modern cultivar ‘Griotte’ of Portugal (Hedrick, 1915; Janick, 2011).

In North America, cherry was brought by the early settlers and thereafter, it was spread westward.

Since 1500-1600 the cherry cultivation spreads in Europe. From the 1700s, in Germany, it becomes habitual delimit the streets with cherry trees. From this time originate some cultivars still known today such as “Germersdorf”, “Dönissens gelbe”, “Napòleon” in Germany and “Bondi”, “Marchiana” and “Turca” in Italy (Figure 1).

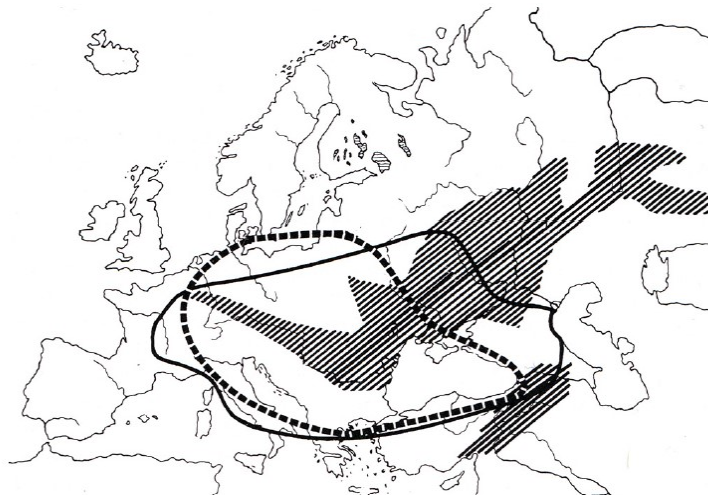

**Figure 1: Distribution of sweet cherry (striped area), sour cherry (solid line), and ground cherry (broken line).**

Source: Faust and Surányi (1997).

**Botanical aspects.** Sweet cherry is a drupe with a central kernel surrounded with fleshy fruit, which contains most of the nutrients and bioactive components. It belongs to the genus *Prunus*, subgenus *Cerasus*, within the Rosaceae family. The predominant species of the subgenus *Cerasus* grown for their fruit are the sweet (*Prunus avium* L.), sour (*Prunus cerasus* L.), and ground cherries (*Prunus fruticosa* Pall.). All *Prunus* species have a basic chromosome number (n) of  $x = 8$ . Sweet cherry has a diploid genome ( $2n = 2x = 16$ ), whereas sour and ground cherries are tetraploid ( $2n = 4x = 32$ ).

**Table 1: Classification report of sweet cherry**

Rank	Scientific name	Common name
Kingdom	Plantae	Plants
Subkingdom	Tracheobionta	Vascular plants
Superdivision	Spermatophyta	Seed plants
Division	Magnoliophyta	Flowering plants
Class	Magnoliopsida	Dicotyledons
Subclass	Rosidae	-
Order	Rosales	-
Family	Rosaceae	Rose family
Genus	<i>Prunus</i> L.	plum
Species	<i>Prunus avium</i> (L.) L.	sweet cherry

Source: USDA, Natural Resources Conversation Service, Plants Database (2017)

According to Bailey (1954), *Prunus avium* is separate into two rather distinct botanic varieties according to fruit color, shape, and texture:

- var. *juliana* W. Koch, which have soft, tender flesh;
- var. *duracina* W. Koch, which have firm fleshed fruits.

Both varieties have fruit with either dark or light-colored flesh. Dark cherries are reddish-purple or mahogany in color whereas light cherries are yellow, usually with a pink to red skin blush.

These groups are black geans, amber geans, hearts, and Bigarreux. Geans have heart-shaped fruits with tender flesh, black geans have dark-colored flesh, and amber geans have light yellow and translucent flesh and skin. Bigarreux have light-colored skin with hard, cracking flesh. Hearts are dark, with flesh texture in between that of geans and Bigarreux (Kappel et al., 2012).

Sweet cherries trees are vigorous, long-lived and become large with strong central leaders and an upright growth habit when untrained and unpruned. They grow in areas with temperate climates. The climatic conditions that are most limiting to production of these species include temperature, precipitation, and wind. Other factors to be considered are sudden freezes during winter, spring frosts, incidence of summer winds, and potential for hail and lightning. Adverse weather conditions at the wrong time can dramatically influence the performance of cherries production often leading to downgrades in fruit yields and/or fruit quality. Cherries prefer light, well drained soils at a pH of 5.5–7.5 (Serradilla et al., 2015). Moreover, these fruits can tolerate soil classes ranging from sandy loam to clay loam, provided there is good drainage. Frequent irrigation inputs are required during the cherry growing season, but not during flowering or ripening. In these periods, rainfall can compromise production.

For these species are important the latency period. It starts in autumn with the movement of roots and woods (storage organs) and the defoliation. After the winter, it grows starting, and then with heat achieve full bloom necessary. However, according to Albuquerque et al. (2008) in *Prunus*, chilling requirements have most effects on flowering time than heat.

Sweet cherry seed has epigeal germination. From hypocotyl born a root system that it is very large and naturally surfaced. The trunk has a smooth and glossy cortex and it has extended transverse lenticel.

The single buds are on the branch second the phyllotaxy order 1/5. The wood bud is got an ellipsoid and pointed form. Flower buds contain one to five flowers clusters or umbels. The formation fruiting has fruit and mix branch, twig floriferous.

The Figure 2 shows that the leaves are alternate, simple, oval-elongated shape, with serrated margins (slightly rounded teeth), obvious darkened glands on thin petiole and generally with more than 8 pairs of veins.

From the botanical point of view sweet cherry fruit is a drupe. The fruit production can be reduced by higher temperatures during bloom, causing acceleration of pollen tube growth rates and reduction of pollen tubes numbers growing along the style. In addition, it causes ovule degeneration accelerates in the ovary (Hedhly et al., 2007). In summer, it is possible the formation of double fruits due to double pistils produced during floral differentiation caused by high temperatures (Beppu et al., 2001).

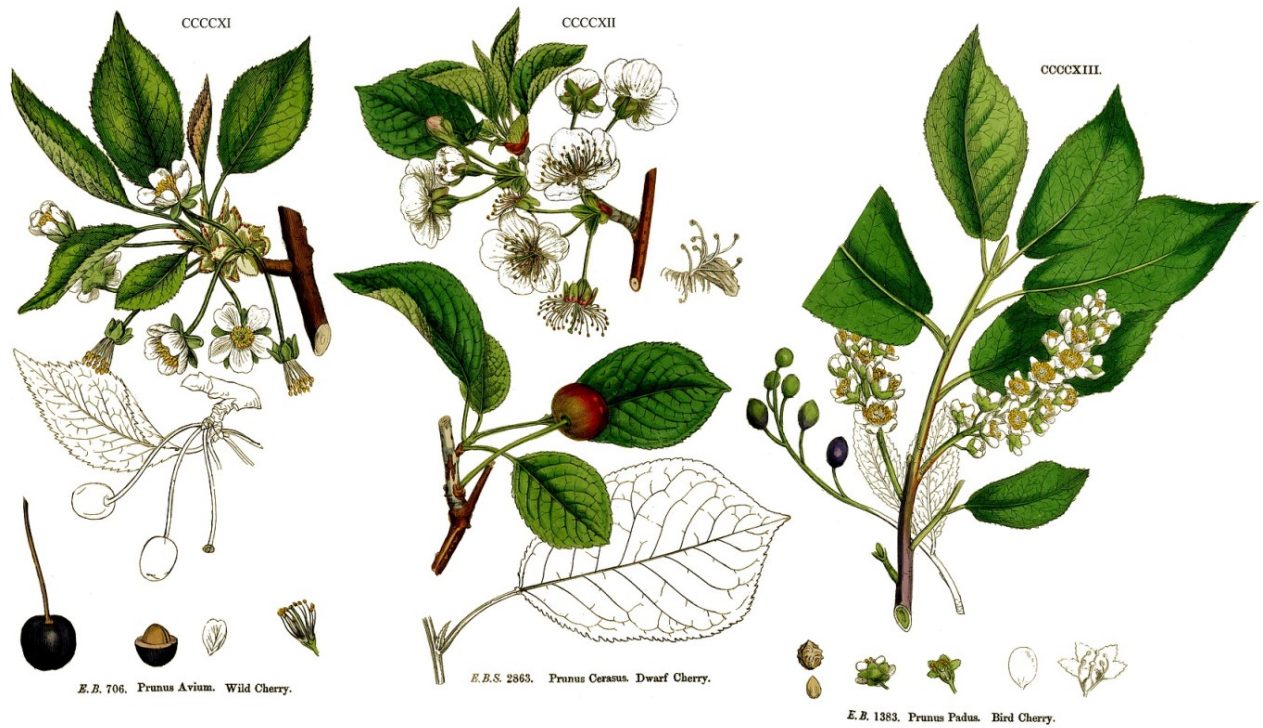

**Figure 2: Sweet cherry (*Prunus Avium*)**

Source: plants.usda.gov

As shows in Figure 3. cherry form varies from round and ovate to long and to heart. Skin colour varies from yellow, to yellow with a pink blush, through shades of mahogany, to almost black.



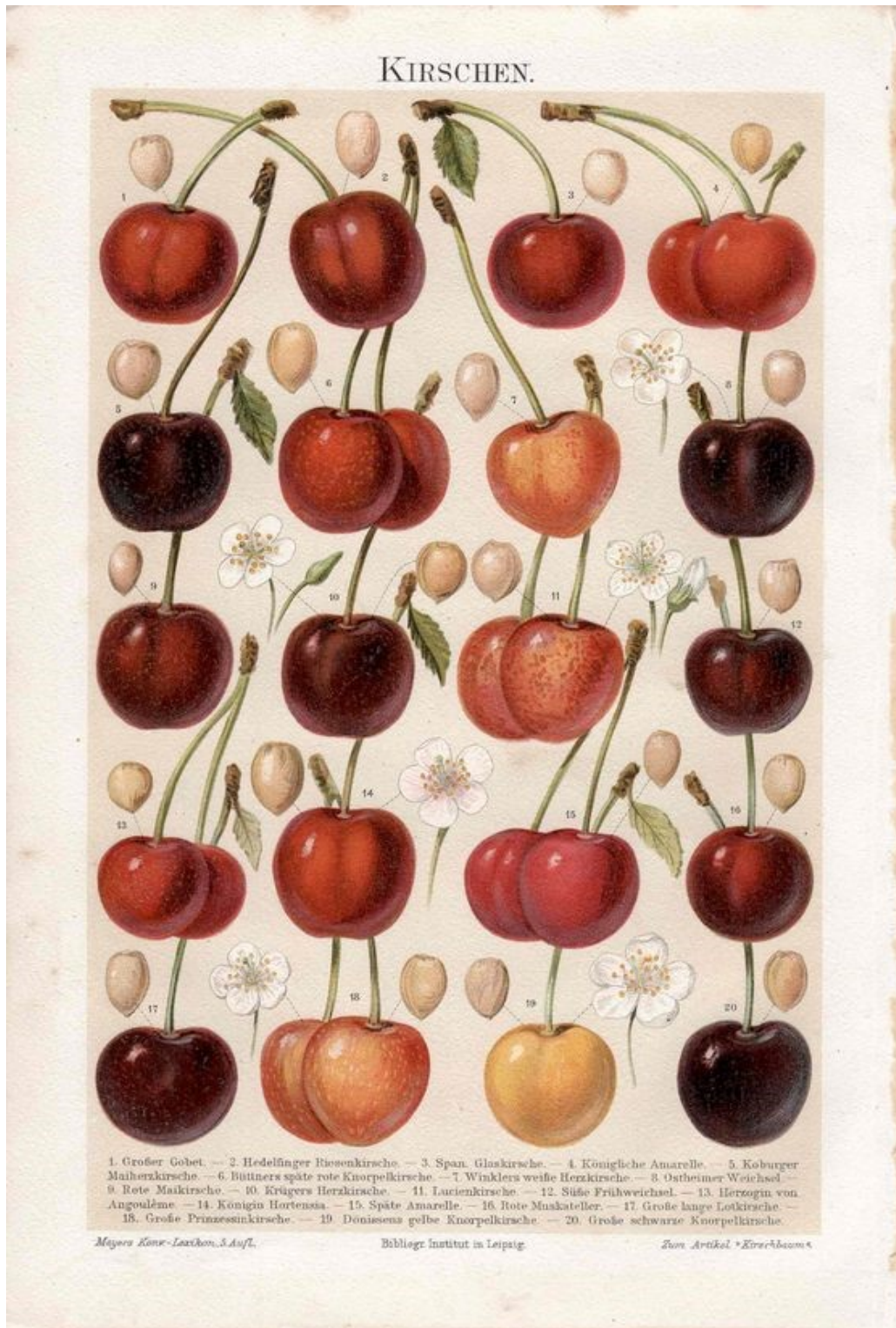

Figure 3: Form and skin colour of cherry  
Source: plants.usda.gov

**Principal agronomic aspects.** To respond the needs of sweet cherry tree it is necessary to assess pedoclimatic characteristics in the cultivation area. The key factor to planning a cherry orchard is the site selection. It is very important to consider: location, rain susceptibility, soil



drainage, type and fertility, water quality, winter chilling, frost and wind. Sweet cherry grows best in fertile, permeable and deep soil, with pH values between 6.5 and 7.2. It is influenced very significantly by the climatic conditions. It is influenced very significantly by the climatic conditions. It is important to select a soil with good drainage soil because cherry roots are sensitive to wet.

Adverse weather conditions at the wrong time can dramatically influence the performance of cherries leading to decrease yields and/or fruit quality. Indeed, temperatures in fall and in early winter, are important for allow to overcome buds' dormancy. Generally, the most of cherry cultivars need cold of about 1000 hours. Moreover, during the spring, too cold temperatures can damage flowers and fruits as depending the phenological stage. The most vulnerable phase to cold returns is when temperatures decrease to  $-1^{\circ}\text{C}$  because damage the fruit. It is optimal a temperature between  $15$  and  $25^{\circ}\text{C}$  during the flowering.

Soil physical-chemical and phytosanitary analysis are very important to know its nutrients availability. In this way, it is possible to administer with precision any deficiencies of elements and quantities. As regard the organic substance, it improves soil structure, it favours the mineral elements solubilisation and an easier root system assimilation. Furthermore, it improves and stimulates the soil microbiological activity. After performing the phytosanitary analyses to verify the absence of parasites and soil pathogens, it proceeds with the soil preparation to make it suitable for the new plantation. The main objective of land preparation is facilitating a correct rainwater flow, avoiding accumulation and stagnation areas, and facilitate soil drainage. If the soil had been destined to tree crops or vine previously, it is necessary to perform a non-deep soil tillage (30-40cm) to remove all the residues from the previous crop and after to proceed with the main processing deep. After deep processing, a second cleaning operation is recommended from root and vegetation residues that they could cause infection to the young root systems of the plants that they will be planted.

In the past cherry orchard was extensive or semi-intensive planting. Nowadays, orchards are planted mid-density and high-density. Mid-density orchard planting (500-800 trees/ha) use hardy and vigorous rootstocks (Lugli and Musacchi, 2009). High-density orchards aim to fill as much as possible the orchard space with high yield trees. These systems could contribute to improve the productivity per hectare, use of labour and orchard inputs. However, to optimise these benefits it is necessary to consider the orchard characteristics such as soil properties and climatic conditions in the cultivation area.

As regard training systems and pruning regimes are changed in the years adapting to the planting and market trends (Lugli and Musacchi, 2009). It is recommended pruning in late summer, but it is possible carry out it also to early autumn when weather condition favour wound trees healing.

For a quality and profitable cherry cultivation, the orchard needs high water availability. For instance, in Apulia region to ensure a good vegetative cycle and to avoid water stress moments, cherry orchard, with 700 plants/ha planting density, needs from 1500 to 2000 m<sup>3</sup>/ha/year. For this reason, it is important the choice of a localized dropper irrigation method which allowing also the fertigation practice. In this way it is possible a rational and environmentally sustainable use of water resource.

The additional benefits of fertigation practice include:

- uniform and precise manner of fertilizers administration;
- efficient regulation of fertilizers based on real plant necessity in relation to the phenological phases and specific climatic condition.

Very important is also the appropriate administration of fertilizers to maintain adequate soil fertility; to avoid nutritional imbalances; to promote high productivity of the plants; and to ensure a constant quality over the years.

Nitrogen (N) is the main element for cherry vegetative and productive activity.

Balanced administrations favour a normal vegetative activity, a good differentiation of buds flower, a good fruits quality and a limitation of rottenness onset especially for the self-fertile varieties that have cluster fruiting.

Phosphorus (P) and potassium (K) are absorbed less than nitrogen. P is very important for the root growth during the planting and during the first years of breeding. K has great importance for the cherry tree because it confers resistance to water and thermal stress (AA.VV., 2009).

Others factors to obtain a quality fruit and a more or less prolonged shelf life are represented by the choice of cherry cultivar, its nutrition, climatological conditions during its development, and the application of phytosanitary treatments to control plagues and diseases. The applications of pre-harvest treatments with fungicides to control post-harvest diseases, such as caused by *Monilinia*, are of particular relevance. Generally, terol-inhibitor fungicides (such as tebuconazole) are used.

In recent decades, the number of new cherry cultivars has increased worldwide. Currently the farmers can choose among more than two hundred sweet cherry cultivars. Different sweet

cherry breeding program (Sansavini, S. and Lugli, S., 2008) have been implement to extending the fruit maturity calendar (to take advantage of higher market prices) and improving some fruit characteristics such as resistance to cracking, flavour, colour, size and flesh firmness (determinants of price in sweet cherry market). According to Sansavini and Lugli (2008), from 1991 to 2004, there were released 230 new cultivars. Table 2 shows the main cultivars of sweet cherry.

**Table 2: Main sweet cherry cultivar**

Cultivar	Origin	Tree growth	Productivity	Blooming time	Ripening time	Fruit characteristics
<b>Aiya</b>	Latvia	Semi-upright, strong vigour	Very good	1 day after "Burlat"	16–24 days after "Burlat"	Round, small, soft, light red
<b>Alex</b>	Romania	Semi-upright, medium to strong vigour	Good to very good	Early/mid-season	5–14 days after "Burlat"	Cordate, large, firm, bright red
<b>Ambrunés</b>	Spain	Upside-down heart-shaped canopy, medium vigour	Moderate	Early	30 days after "Burlat"	Heart-shaped, large and very firm fruit, dark rose
<b>Andrei</b>	Romania	Semi-upright, medium vigour	Very good	4 days before "Burlat"	5–14 days after "Burlat"	Cordate, large, firm, brown red
<b>Areko</b>	Germany	Pyramidal with spreading branches, medium vigour	Very good	Late	16 days after "Burlat"	Cordate, large, firm, brown red
<b>Axel</b>	Hungary	Semi-upright, moderate vigour	Very good	Early	40–45 days after "Burlat"	Roundish to elongated, medium to large, medium firm, deep purple
<b>Bedel (Bellise™)</b>	France	Semi-upright, spreading, medium to strong vigour	Very good	Early	4–8 days after "Burlat"	Reniform, medium to large, firm, light red
<b>Belge</b>	France	Upright, medium vigour	Good	Late	23–27 days after "Burlat"	Heart-shaped, large, firm, light red
<b>Benisayaka</b>	Japan	Slightly upright, vigorous	Very good	Unknown	Early	Blunt to cordate, medium to small size, firm, blush type
<b>Benishuhou</b>	Japan	Slightly spreading, medium vigour	Very good	Unknown	Late	Reniform, medium to large, firm, blush type
<b>Benton</b>	USA	Upright, strong vigour	Medium to good	4 days before "Burlat"	19 days after "Burlat"	Reniform, large to very large, firm, mahogany red
<b>Bing</b>	USA	Erect branches, vigorous	Very good	Early/mid-season	20–25 days after "Burlat"	Roundish, large to very large, very firm, red to black
<b>Black Star</b>	Italy	Semi-upright, medium vigour	Very good	Early	Close to "Summit"	Round, large to very large, very firm, red to black

Sustainability and innovation of the sweet cherry supply chain

Cultivar	Origin	Tree growth	Productivity	Blooming time	Ripening time	Fruit characteristics
<b>Boambe de Cotnari</b>	Romania	Semi-upright, low to medium vigour	Very good	1 day before "Burlat"	15–16 days after "Burlat"	Reniform to cordate, medium to large, medium firm, blushed type
<b>Brooks</b>	USA	Upright, vigorous	Good	Same as "Burlat"	10–17 days after "Burlat"	Reniform, large, firm, red to dark red
<b>Bryanskaya rozovaya</b>	Russia	Spreading, strong vigour	Very good	2–3 days after "Burlat"	24–31 days after "Burlat"	Oblate, small, firm, blush type
<b>Burlat</b>	France	Upright, strong to very strong vigour	Very good	Early/mid-season	Very early	Oblate, medium size, medium to low firmness, red
<b>Büttners Späte Rote Knorpelkirsche</b>	Germany	Upright, very vigorous	Very good	Early/mid-season	23–29 days after "Burlat"	Heart-shaped, medium size, very firm, blush type
<b>Cambrina</b>	USA	Semi-upright, strong vigour	Very good	0–4 days after "Burlat"	15–22 days after "Burlat"	Reniform, medium to large, firm, blush type
<b>Carmen</b>	Hungary	Semi-upright, moderate vigour	Medium to good	Early/mid-season	10–12 days after "Burlat"	Flattened, round, very large, firm, deep red
<b>Cavalier</b>	USA	Upright spreading canopy, moderately vigorous moderate branching (compared with "Bing")	Moderate, not precocious	Early to mid-season	13–17 days after "Burlat"	Globose to slightly oblate, medium to large, firm, dark red
<b>Chelan</b>	USA	Upright spreading canopy, moderately vigorous moderate branching (compared with "Bing")	Very good	Early	10–12 days after "Burlat"	Roundish, medium to large, firm, red
<b>Early Korvik</b>	Czech Republic	Spreading, medium vigour	Very good	Mid- to late season	3 weeks after "Burlat"	Heart-shaped, large, firm, dark to black-red
<b>Emperor Francis (syn. "Kaiser Franz (Josef)")</b>	Germany-Austria	Spreading, medium vigour	Good	Mid-season	18 days after "Burlat"	Roundish heart-shaped, medium size, firm, blush type
<b>Ferrovía</b>	Italy	Upright, low to medium vigour	Good	Late	20–22 days after "Burlat"	Heart-shaped, large, firm, pink
<b>Folfer</b>	France	Semi-upright, medium to strong vigour	Very good	Very early	7–13 days after "Burlat"	Round, large to very large, very firm, red.
<b>Germersdorfer</b>	Germany	Upright, semi-strong to strong vigour	Very good	Late	23–27 days after "Burlat"	Heart-shaped, large, firm, crisp, light red
<b>Giorgia</b>	Italy	Upright, vigorous	Very good	Early/mid-season	7–11 days after "Burlat"	Heart-shaped, large, firm, red
<b>Grace Star</b>	Italy	Semi-upright, strong growth	Very good	Mid-season	14–20 days after "Burlat"	Reniform, very large, medium firm, light red
<b>Hedelfinger</b>	Germany	Upright to spreading, strong vigour	Very good	Medium-late to late	25 days after "Burlat"	Ovoid to heart-shaped, medium to large, firm, brown to red
<b>Hongdeng</b>	China	Upright, strong growth	Very good	"Burlat"	3 days after "Burlat"	Reniform, large, medium firm, red

## Sustainability and innovation of the sweet cherry supply chain

Cultivar	Origin	Tree growth	Productivity	Blooming time	Ripening time	Fruit characteristics
<b>Kordia</b>	Czech Republic	Upright, pyramidal with spreading branches, medium vigour	Very good	Late	18–25 days after "Burlat"	Heart-shaped, large, firm, red to dark violet
<b>Krupnoplidna</b>	Ukraine	Round crown, vigorous	Very good	Early	17–23 days after "Burlat"	Flat-round, large to very large, firm, red
<b>Lambert</b>	USA	Upright, vigorous	Very good	Medium-late	20 days after "Burlat"	Heart-shaped, medium to large, firm, purple red
<b>Lapins</b>	Canada	Very upright, vigorous	Very good	Early	25–28 days after "Burlat"	Roundish to heart shaped, medium to large, firm, purple red
<b>Maria</b>	Romania	Spreading, medium vigour	Good to very good	1–2 days after "Burlat"	10–15 days after "Burlat"	Cordate, large, firm, dark red
<b>Melitopolska Chorna</b>	Ukraine	Semi-upright, vigorous	Very good	Early/mid-season	30–35 days after "Burlat"	Round, medium size, firm, dark red
<b>Merchant</b>	UK	Spreading, medium vigour	Very good	Early/mid-season	15 days after "Burlat"	Moderate size, black
<b>Napoleon (syn. "Royal Ann")</b>	Germany	Medium upright, vigorous	Good to very good	Medium to late	18–22 days after "Burlat"	Heart-shaped, medium size and firmness, blush type
<b>Narana</b>	Germany	Spreading, medium vigour	Very good	Early	2 days before "Burlat"	Flat-round, medium to large, medium firm, dark red
<b>Prime Giant (syn. "Giant Red", "Mariant"; Giant Ruby™)</b>	USA	Semi-upright, medium to strong vigour	Very good	"Burlat"	7–18 days after "Burlat"	Reniform to roundish, very large, firm, dark red
<b>Rainier</b>	USA	Upright, poor branching, vigorous	Very good	Early	18–22 days after "Burlat"	Slightly obovate, large, firm, blush type
<b>Regina</b>	Germany	Pyramidal with spreading branches, vigorous	Very good	Very late	28–35 days after "Burlat"	Flat-round to round, medium to large, very firm, dark red
<b>Rivedel</b>	France	Semi-upright, medium to strong vigour	Very good	Early	0-4 days before "Burlat"	Reniform round, large, low firmness, red
<b>Rubin</b>	Romania	Spreading, good branching, low to medium vigour	Very good	Very late	25–30 days after "Burlat"	Cordate elongated, large, firm, light red
<b>Samba ®</b>	Canada	Semi-upright, medium-strong vigour	Good	2–6 days before "Burlat"	15–25 days after "Burlat"	Elongated, large, firm, harvest when dark red
<b>Sandra Rose</b>	Canada	Spreading, vigorous	Very good	Mid-season	16–24 days after "Burlat"	Reniform, large, medium firm, dark red
<b>Santina</b>	Canada	Spreading, vigorous	Very good	Mid-season	2–10 days after "Burlat"	Reniform, medium to large, firm, red
<b>Satonishiki</b>	Japan	Vigorous	Very good	5 days after "Burlat"	15–24 days after "Burlat"	Heart-shaped, medium size and firmness, blush type

Sustainability and innovation of the sweet cherry supply chain

Cultivar	Origin	Tree growth	Productivity	Blooming time	Ripening time	Fruit characteristics
<b>Schneiders Späte Knorpel</b>	Germany	Strong growth, high pyramidal crown	Very good	Medium-late to late	17 days after "Burlat"	Cordate, large, firm, brown red
<b>Skeena</b>	Canada	Spreading, vigorous	Very good	Early	25–33 days after "Burlat"	Elongated, large, very firm, dark red
<b>Staccato™</b>	Canada	Spreading, medium to strong vigour	Very good	Mid-season/late	37–42 days after "Burlat"	Elongated, medium to large, firm, dark red
<b>Stella</b>	Canada	Upright, vigorous	Very good	Semi-early	15–20 days after "Burlat"	Heart-shaped, medium size, medium firm to firm, dark red
<b>Sumele (Satin™)</b>	Canada	Semi-upright, strong to very strong vigour	Good	"Burlat"	14–24 days after "Burlat"	Cordate elongated, large, very firm, dark red
<b>Summit</b>	Canada	Upright, poor branching, vigorous	Medium to very good	Late to very late	15–22 days after "Burlat"	Heart-shaped, very large, medium firm, pale pink
<b>Sumnue (Cristalina™)</b>	Canada	Spreading, medium to strong vigour	Very good	Mid-season	9–17 days after "Burlat"	Reniform elongated, large, medium firm, black
<b>Sumtare (Sweetheart™)</b>	Canada	Spreading, strong vigour	Very good	Mid-season	30–35 days after "Burlat"	Elongated, medium to large, very firm, red
<b>Sweet Aryana®</b>	Italy	Upright, medium to strong vigour	Very good	Early	3–5 days after "Burlat"	Heart-shaped, large, firm, shiny dark red
<b>Sweet Gabriel®</b>	Italy	Semi-upright, low to medium vigour	Very good	Mid-season	11–14 days after "Burlat"	Heart-shaped, very large, firm, shiny dark red
<b>Sweet Lorenz®</b>	Italy	Upright, low vigour	Very good	Early	8–10 days after "Burlat"	Heart-shaped, very large, very firm, shiny dark red
<b>Vera</b>	Hungary	Semi-upright, moderate vigour	Good	Early	10–12 days after "Burlat"	Flat-round, large, firm, deep red

Source: Quero-García et al. (2017)

**Nutritional aspects.** Sweet cherry is one of the most appreciated fruits worldwide thanks to the organoleptic characteristics (taste, sweetness and colour) as well as the natural presence of nutrients, antioxidants and other healthy compounds such as flavonoids, vitamins, anthocyanins and phenolic (Esti et al., 2002, Faniadis et al., 2010, Girard and Kopp, 1998, Liu et al., 2011, Mozetič et al., 2002, Serrano et al., 2009 end Usenik et al., 2010).

The Table 3 (USDA, 2016) shows that the major constituent of this fruit is water (82.25 g) and contains 16% of carbohydrates represented by sugar (12.82g) and fibre total dietary (2.1 g). The levels of sugar present in cherry represent an important aspect because contributed to flavour and determines the acceptability by customers.

Generally, the fruit contains different types of sugar such as sucrose, glucose (dextrose) and fructose. As regard the fibre content, cherry contains 2.1g of dietary fibre per 100 g. Although

it is not a high quantity, it can promote health qualities of cherries in the human diet. According to Suter (2005) and Keenan et al. (2006), high fibre diets contribute to blood glucose control, reduce cholesterol levels, and have indirect effects on weight control because they have effects on satiety. Moreover, cherries present reduced levels of fat (in particular saturated fat) and reduced calories intake being cholesterol-free (Bastos et al., 2015; McCune, et. al., 2011).

Another important component are organic acids that contribute to flavour and tart or sour taste of fruit. Generally, in sweet cherries are present malic acid ranging from 0.3 to 0.8g/100 g fresh weight (Usenik, Fabčič and Štampar, 2008; McLellan and Padilla-Zakour, 2004) and aspartic acid equal to 0.569g/100 g fresh weight (USDA, 2016).

In addition to protein (1.06 g), cherries content also minerals such as potassium, calcium, magnesium, phosphorous and fluoride; vitamins as ascorbic acid (vitamin C), vitamins A, K, beta-carotene; phenolic compounds and polyphenols such as flavonoids and anthocyanins that contribute to several health benefits (Chockchaisawasdee et al., 2016). Some innovation technologies are the extraction of phenolic compound from cherry stems (a source of antioxidants) since their concentration is higher than fleshy fruit (Bastos et., al 2015).

As regard minerals sweet cherries contain high levels of potassium (222 mg fresh weight consumed) and the absence of sodium (Table 3) contributing to reduce the risk of hypertension and stroke (He and MacGregor, 2003; Vaskonen, 2003). In fact, according to Ding and Mozaffarian (2006) dietary approaches with low sodium and increase potassium intake can decrease blood pressure and reduce stroke risk.

Anthocyanins represent another compound of cherry because have antioxidant proprieties. Moreover, are indicators of maturity because the red colour of cherry fruit deriving from the presence of anthocyanins. The quantity of these compounds depending on fruit variety. Some cultivar such as Burlat, Sweet Early, Early Star and Ferrovia (84.6, 70.6, 47.2 and 27 mg/100g fresh weight respectively) contains major quantity of anthocyanins than others e.g Newstar, Genovese and Napoleona Grappolo (25, 25.1 and 14.3 mg/100g fresh weight respectively) (Chockchaisawasdee et al., 2016).

Sweet cherry is rich of anthocyanin cyaniding (30.21 mg/100g fresh weight). The concentration of the latter is most higher than others fruit such as tart cherry, peaches, plums and red grapes. Thanks to the presence of anthocyanin (with relevant antioxidant properties),

sweet cherry contributes health-promoting effects because that improve the age-related deficits in neuronal and behavioural functions.

Cherries contain also quercetin that has potent antioxidant activity and thanks its unique catechol structure could play a beneficial role in reduction of free radical. However, the consumption of an average serving of cherries that contain quercetin is lacking to have any significant effect on oxidant stress or inflammatory biomarkers. Nevertheless, in conjunction with other antioxidant and anti-inflammatory plays well its role (McCune et. al., 2011).

The presence of bioactive compounds (fibre, anthocyanins cyanidin, vitamin C, and carotenoids) allowed sweet cherry to be recognized as fruit to the prevention of cardiovascular diseases, cancer and other diseases related with oxidative stress (Bastos et. al, 2015; Serra et al., 2011a; Serra et al., 2011b; Beattie, Crozier, and Duthie, 2005).

**Table 3: Nutrient value for sweet cherry  
(Nutrient values and weights are for edible portion)**

Nutrient	Unit	Value (100g)	Data points	Std. Error	Min	Max
<b>Proximate</b>						
<b>Water</b>	g	82.25	12	0.546	77.9	86.5
Energy	kcal	63	--	--	--	--
Energy	kJ	263	--	--	--	--
<b>Protein</b>	g	1.06	8	0.075	0.94	1.2
<b>Total lipid (fat)</b>	g	0.20	8	0.017	0.05	0.5
<b>Ash</b>	g	0.48	8	0.065	0.35	0.55
<b>Carbohydrate by difference</b>	g	16.01	--	--	--	--
Fibre, total dietary	g	2.1	8	0.212	1.7	2.4
Sugars, total	g	12.82	--	--	--	--
Sucrose	g	0.15	10	0.081	0.0	0.64
Glucose (dextrose)	g	6.59	13	0.615	4.77	16.14
Fructose	g	5.37	13	0.440	3.2	10.22
Lactose	g	0.00	4	0.000	0.0	0.0
Maltose	g	0.12	5	0.120	0.0	0.24
Galactose	g	0.59	4	0.307	0.07	1.29
<b>Minerals</b>						
Calcium, Ca	mg	13	64	0.101	11.0	27.0
Iron, Fe	mg	0.36	65	0.005	0.03	0.92
Magnesium, Mg	mg	11	65	0.070	7.0	19.0
Phosphorus, P	mg	21	63	0.135	13.0	29.0
Potassium, K	mg	222	65	1.196	129.0	267.0
Sodium, Na	mg	0	64	0.015	0.0	1.0
Zinc, Zn	mg	0.07	65	0.002	0.0	0.67
Copper, Cu	mg	0.060	65	0.001	0.013	0.17



## Sustainability and innovation of the sweet cherry supply chain

Nutrient	Unit	Value (100g)	Data points	Std. Error	Min	Max
Manganese, Mn	mg	0.070	65	0.001	0.04	0.192
Fluorine, F	µg	2.0	9	--	--	--
<b>Vitamins</b>						
Vitamin C, total ascorbic acid	mg	7.0	8	1.588	4.9	10.1
Thiamin	mg	0.027	8	0.004	0.02	0.035
Riboflavin	mg	0.033	8	0.004	0.018	0.05
Niacin	mg	0.154	8	0.006	0.145	0.165
Pantothenic acid	mg	0.199	8	0.017	0.165	0.217
Vitamin B-6	mg	0.049	8	0.004	0.043	0.057
Folate, total	µg	4	4	0.850	3.0	6.0
Folate, food	µg	4	4	0.850	3.0	6.0
Folate, DFE	µg	4	--	--	--	--
Choline, total	mg	6.1	--	--	--	--
Vitamin A, RAE	µg	3	--	--	--	--
Carotene, beta	µg	38	6	10.929	25.0	60.0
Vitamin A, IU	IU	64	--	--	--	--
Lycopene	µg	0	2	--	0.0	0.0
Lutein + zeaxanthin	µg	85	2	--	84.0	85.0
Vitamin E (alpha-tocopherol)	mg	0.07	5	0.010	0.06	0.08
Tocopherol, beta	mg	0.01	5	0.010	0.0	0.02
Tocopherol, gamma	mg	0.04	5	0.035	0.0	0.07
Vitamin K (phylloquinone)	µg	2.1	5	0.600	1.5	2.7
<b>Lipids</b>						
Fatty acids, total saturated	g	0.038	--	--	--	--
Fatty acids, total monounsaturated	g	0.047	--	--	--	--
Fatty acids, total polyunsaturated	g	0.052	--	--	--	--
Phytosterols	mg	12	--	--	--	--
<b>Amino Acids</b>						
Tryptophan	g	0.009	--	--	--	--
Threonine	g	0.022	--	--	--	--
Isoleucine	g	0.020	--	--	--	--
Leucine	g	0.030	--	--	--	--
Lysine	g	0.032	--	--	--	--
Methionine	g	0.010	--	--	--	--
Cystine	g	0.010	--	--	--	--
Phenylalanine	g	0.024	--	--	--	--
Tyrosine	g	0.014	--	--	--	--
Valine	g	0.024	--	--	--	--
Arginine	g	0.018	--	--	--	--
Histidine	g	0.015	--	--	--	--
Alanine	g	0.026	--	--	--	--

## Sustainability and innovation of the sweet cherry supply chain

Nutrient	Unit	Value (100g)	Data points	Std. Error	Min	Max
Aspartic acid	g	0.569	--	--	--	--
Glutamic acid	g	0.083	--	--	--	--
Glycine	g	0.023	--	--	--	--
Proline	g	0.039	--	--	--	--
Serine	g	0.030	--	--	--	--
<b>Flavonoids</b>						
<b>Anthocyanidins</b>						
Cyanidin	mg	30.21	83	4.210	0.72	145.09
Pelargonidin	mg	0.3	74	0.030	0.0	1.88
Peonidin	mg	1.5	83	0.270	0.0	10.99
Flavan-3-ols						
(+)-Catechin	mg	4.4	40	0.530	0.0	14.9
(-)-Epigallocatechin	mg	0.3	11	0.260	0.0	2.89
(-)-Epicatechin	mg	5.0	84	0.350	0.43	27.04
(-)-Epicatechin 3-gallate	mg	0.1	11	0.010	0.0	0.2
Isorhamnetin	mg	0.1	4	0.010	0.04	0.07
Kaempferol	mg	0.2	9	0.080	0.0	0.67
Myricetin	mg	0.1	9	0.050	0.0	0.45
Quercetin Isoflavones	mg	2.3	80	0.020	0.1	6.78
<b>Proanthocyanidin</b>						
Proanthocyanidin dimers	mg	3.5	8	0.840	2.38	4.8
Proanthocyanidin trimers	mg	2.7	8	0.940	1.85	4.9
Proanthocyanidin 4-6mers	mg	6.7	5	0.780	5.96	7.74
Proanthocyanidin 7-10mers	mg	1.8	5	0.150	1.6	2.03

Source: USDA (2016)

According to McCune et al. (2011) nutritional composition of cherries is a good source of beta-carotene, as well as flavanol, quercetin and anthocyanins (such as Cyanidin, Pelargonidin, Delphinidin, Peonidin, Malvidin) (Figure 4). Moreover, the chemical composition of cherries depends on different factor such as the cultivar, maturation stage, agricultural practices, and environmental conditions.

For all these sweet cherry qualities it is important to find innovative technologies to extract their bioactive compounds and destine to utilization in the health and pharmaceutical industries.

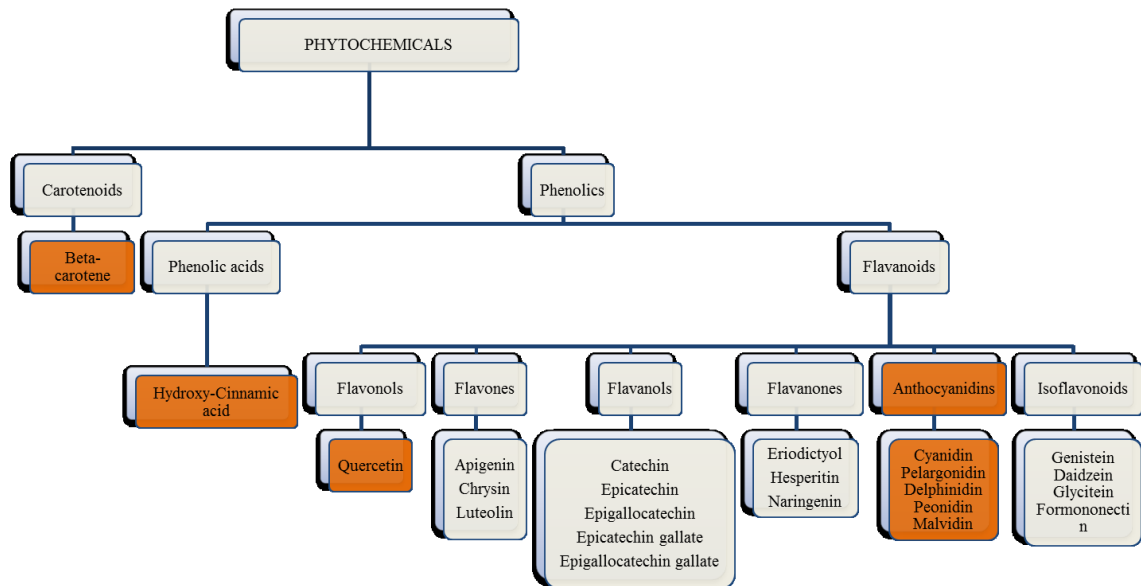

**Figure 4: Bioactive Food Components in Sweet Cherries**

Source: McCune et al. (2011)

## 1.2 Sweet cherry processing: technologies and innovations

The product and process innovation of sweet cherry supply chain has concerned not only the agricultural but also the processing phase. As regard the first, as above mentioned, the product innovation concerns in breeding programmes started to develop new sweet cherry cultivars able to expand the marketing calendar (Sansavini and Lugli 2005; Lang et al. 1998; Kappel et al., 1998) and to improve organoleptic characteristics (i.e. taste, sweetness and colour). Moreover, a new layout introduced which consist in mid and high-density planting system. These can decrease cherry cultivation costs, labours and orchard inputs and improve yield (Kappel et al, 2012; Sansavini and Lugli, 2008). Regarding the processing phase, there are implemented a series of innovation that have regarded principally the storage and commercialization phase.

Generally sweet cherry deteriorates rapidly after harvest and lose their quality in a short period of time ranging from several days to 1–2 weeks, depending on plant species and

cultivar (Valero and Serrano, 2010). To safeguard the quality, sweet cherries must be hand-picked and at the right time of ripening. Generally, the harvesting is done in the early morning to reduce the excessive overheating of fruits collecting by hand. Usually, mechanical harvesting avoided because could causes significant damage on fruit surface and which make it unacceptable to the consumers and cause economic loss to the farmers. According to Crisosto et al. (2003), sweet cherry visual characteristics is an important organoleptic aspect considered by consumers. Indeed, the latter prefer cherries with imperfection absence, bright and shiny surface, intensity colour of skin and stem and good fruit size. Others aspect considering by consumer to appreciate cherry fruit quality are represented from taste, texture and flavour. So, to preserve cherry quality, it has to processed in strict treatment conditions to prevent negative alterations of organoleptic aspects and to satisfy consumers request. Cherry harvested are processing both to fresh market and to food industry (frozen, brined, candied, dried, juice, wine, jams and jellies).

After harvesting, sweet cherries destined for the fresh market are transported to the collected centre where they are processed in just one stage using following treatments: hydrocooling, sizing, sorting, packaging, labelling and finally cold storage. Low temperature storage is used to delay the postharvest deterioration process, although in some cases this treatment is not enough to maintain fruit quality during handling, transport and commercialization.

To safeguard the quality and retard the sweet cherry decay process, the fruit is cooled as quickly as possible to near its optimum storage temperature and maintained at a constant temperature throughout necessary period until it reaches consumers.

The fastest and effective way of cooling cherries is represented by hydrocooling. It is an efficient way to remove heat and to clean at the same time. There are immersion or rain-type hydrocoolers in the latter, fruit is carried on a belt under a constant flow of cold water. The water droplets must fall less than 30 cm to avoid damage to the surface of the fruit. In immersion hydrocooler fruit is carried on a belt immersed in cold water (0°C). (Alonso and Alique, 2006). It is recommended the use of water chlorination and disinfectant to reduce microbial pathogens and a proper cleaning of the equipment used in the collected centre.

To the cherries harvested in clusters are used a cluster cutter that consist of a fruit conveyor belt that crosses several series of alternate revolving saws with protectors that prevent the fruit from being cut. Lately, the cluster cutters use a water flume system to carry the fruit and reduce possible damage.

After the cooling, sweet cherries they are transported by roller immersed in cold water to be calibrate. Generally, calibration can carry out in two or more size categories on the basis of dimension or weight fruit. Sizing consist in lines in fresh water with divergent rollers that move the fruit on inclined plane to facilitate the flow and reduce to the minimum possible fruit damages during the processing. Cherries not conform to the fresh market are used to industrial processing. Instead, cherries conform to the fresh market are transfer along the fresh water flume toward the sorting lines. In this stage cherries with damage (such as double cherries, cracked, soft, etc.) are eliminated.

After calibration and sorting sweet cherries are to be packaged. Still in a bed of water they are transfer along flumes to the different packagers. The packaging of cherries change based on different request of the market. Generally, cherries are packaged in cardboard boxes weight from 2 to 5 kg for the wholesaler market. In addition, for supermarkets and hypermarkets cherries are packed in smaller format from 0.5 to 1 kg in PET clamshell. Sometimes, there are baskets of 500 g that are film wrapped horizontal, so-called flow-pack system (Figure 5), with macro-perforated or micro-perforated films. Generally, cherries are filled automatically using horizontal multi-head weighing that weigh the exact amount of cherries for the package.



**Figure 5 Horizontal flow-pack wrapping**

Source: Alonso and Alique, (2006)

After packaging, sweet cherries are storage to maintain stems green and fruits fresher. The temperature recommended is between from  $-0.5^{\circ}$  to  $2.5^{\circ}\text{C}$ . In addition to the temperature storage, it is also very important humidity during storage because influence the sweet cherry quality and the shelf life. Humidity non-conform during storage, it contributes to the water loss of cherries and their stem accelerating the fruit decay. For this reason, the optimal humidity for the storage of cherries is between 90-95% (Chockchaisawasdee et al., 2016). Generally, to maintain storage chain and to extend the sweet cherry shelf life are used different storage treatment: controlled atmosphere (CA) and modified atmosphere packaging (MAP) and edible coatings. As regard-controlled atmosphere (CA) and modified atmosphere packaging (MAP) the lower oxygen ( $\text{O}_2$ ) levels and higher levels of carbon dioxide ( $\text{CO}_2$ )

levels during the storage improve the period of storage in terms of quality parameters such as pigment metabolism, phenolic metabolism and volatile compound metabolism.

Generally, sweet cherries are destined for the fresh market but they are also processed into canned, frozen, brined, candied, and dried forms, juice, wine, jams, and jellies.

Fruits that are intended for industry processing have to the following prerequisite: optimal ripeness, free from microbiological deterioration, homogenous and intense colour, large fruit size, thin fruit skin, stiff fruit flesh. After harvesting cherries are transported to the processing industry in plastics box and after sampling and quality grading they are stored in cool warehouse for some days before processing into different products. As shows Figure 6, the principal sweet cherry processing is:

- **Quick-Frozen:** cherries arrived in processing industry, after reception processes (such as quality evaluation and selection), it begins the processing with precooling that it is carried out in cooling containers at 0-5°C. If cherries are pitted, the next phase is the stem removing. The Freezing can be obtained by continuous, band-based, or fluidization type equipment. The process is complete when the core temperature is -25°C. Successively, frozen cherries produced are again sorting and grading to improve the quality. Finally, fruits are ready to the trade in polyethylene bags or multilayer boxes. Moreover, cherries can be ulterior processed. Indeed, smaller packages are sell in supermarket for the families and large packages are allocate to others industries such as confectionery and canning.
- **Aseptic Puree:** the pulp of sweet cherries is used such as ingredient in several fruit-based products such as baby foods, jams, juices, fruit sauces, etc. To produce aseptic pulp, it is need that cherries pass stringent quality control concerning: appropriate ripeness, free from defects, insects, pathogens and foreign material. First of all, fruits are washed in a water bath. Consequently, cherries are disintegrated in little irregular particles. In this way, the skin is separate to the flesh. Generally, the disintegrator equipment is situated above the precooking device that push cherry in the precooking machine. This last phase is very important because makes the tissue structure of the fruit soft and flowing and so the pressing is carry out more efficiently, without activating fruit enzymes that otherwise it would cause color and texture damages in the pulp during subsequent processing phase. At this point it is obtain the pulp and it is centrifuged. After, the centrifuged pulp is separate from the soft parts to the others part

with the sieve. Subsequently, cherries pulp is homogenized and deaerated. Finally, cherry puree is packaged with aseptic technology.

- **Concentrate:** cherry concentrate is produced as material to different fruit products such as juices, syrups, powdered fruit drinks, fruit gels and baby foods. To obtain a good cherry concentrate, the peduncle is removed to avoid changes in the color and in the quality of the juice. To obtain optimal result it is important remove moldy and deteriorated fruits during the sorting phase.
- **Dried:** fruits are product from raw or frozen cherries and it is dried without stems in tunnel or tray-based dryer machines. Generally dried cherries are the ingredients of fruit snacks, muesli mixes, muesli bars, fruit teas, and other products. Drying it can take place also in vacuum-seal. The advantages derived by this technology is that allow a good product rehydration ability.
- **Canned:** to obtain this product cherries are heat-treated in sweet syrup. It is possible, also, add sugar, alcohol, vinegar, spices. Canned cherries are packaged in jars and it is added syrup and for last, they are pasteurized.
- **Crystallized cherries:** their preparation is the same as the canned cherries, but it is increased the quantities of sugar content.
- **Cherries syrup:** it is product at cold and warm temperatures with sugar addition, homogenization, and filling. The conservation process is done by heat treatment or with the addition of preservatives.
- **Jam:** the production of cherry jam consists in the following phases: weighing ingredients, mixing acidulates, stabilizers, sweeteners as per the formulation and finally heating the fruits about to 70-80°C. The jam can be cooked also in vacuum-sealed (Stéger-Maté, 2012).



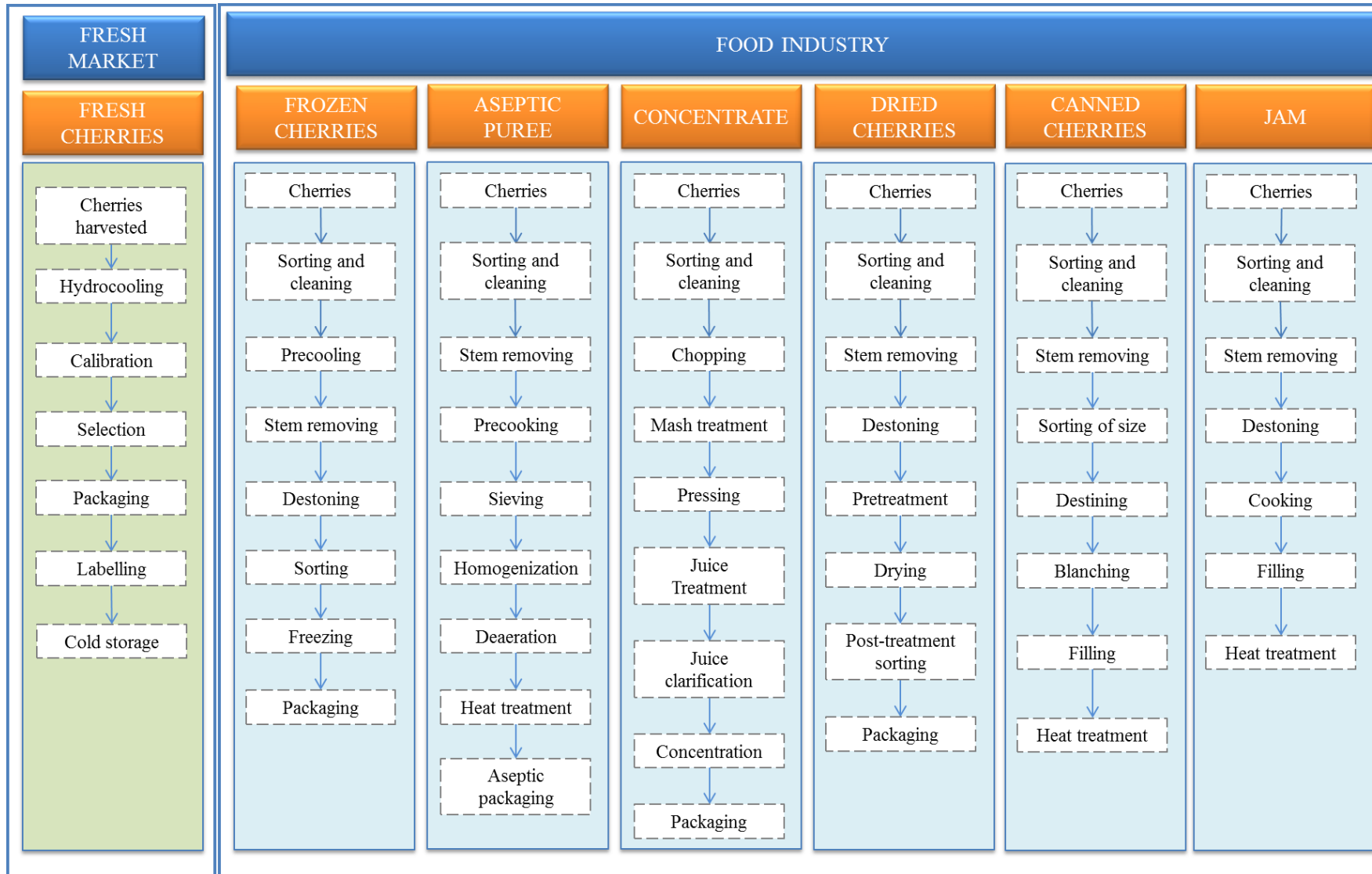

Figure 6: Principal sweet cherry processing (personal elaboration)

### 1.3 Innovative technologies in the sweet cheery supply chain

In the last years, interest is increasing for new processed methods and products obtained from sweet cherries such as bioactive compounds recovered from by-products or waste (i.e. stems) and addressed to food or/and pharmaceutical industry. (Chockchaisawasdee et al., 2016; Serra et al., 2010).

Figure 7 shows the different methods to improve and to optimize the extraction of phenolic and anthocyanins from sweet cherry. According to Kim et al. (2005) it is possible to produce a phenolic rich extract and anthocyanins using sweet cherry by-products or lower quality sweet cherries. This method is made up of many processing phases such as homogenization and sonication with methanol. The phenolic extract obtained with this method was again processed to achieve pure anthocyanins using elution solvent. The result did not satisfy the expectation since the anthocyanin obtained was low and the use of methanol solvent is not desirable from a health point of view. For this reason, it was developed a method to produce anthocyanin rich extract without using solvents (Grigoras et al., 2012).

According to Chockchaisawasdee et al., 2016, methods (such as membrane filtration, cryoconcentration, vacuum drying, freeze and spray drying) should be improved to optimise the extraction process of bioactive components from sweet cherries. Moreover, according to Scoma et al., (2012) it is possible enrich these bioactive components using methods already adopted from other sources.

However, further studies are necessary to develop methods to improve the extraction of bioactive components of sweet cherry maintaining its health benefits. In this way could be encouraged the use of the active natural compounds not only in the food sector but also in the health and pharmaceutical industries. However, it is important that future extraction and processing methods must be both environmental and economical sustainable.

In fact, in the last twenty years customers have increased awareness of the importance of healthy nutrition and the environmental impact deriving from food production (Burt, 2004; Johnston et al., 2014). In particular in the food supply chain, processing and packaging are the most impactful phases since they contribute more than 25% to the waste production (FAO, 2011). Cherries are packed using often polylactic acid (PLA) and polyethylene terephthalate (PET) clamshells. Nowadays, the disposal and recyclability of packaging material are very important issue. As it is showed in this research, PET used to the cherry packaging has a high environmental impact (see

section 2.2.8). Therefore, these customers' requests have encouraged producers to research a new packaging system more sustainability that extends the shelf life of food.

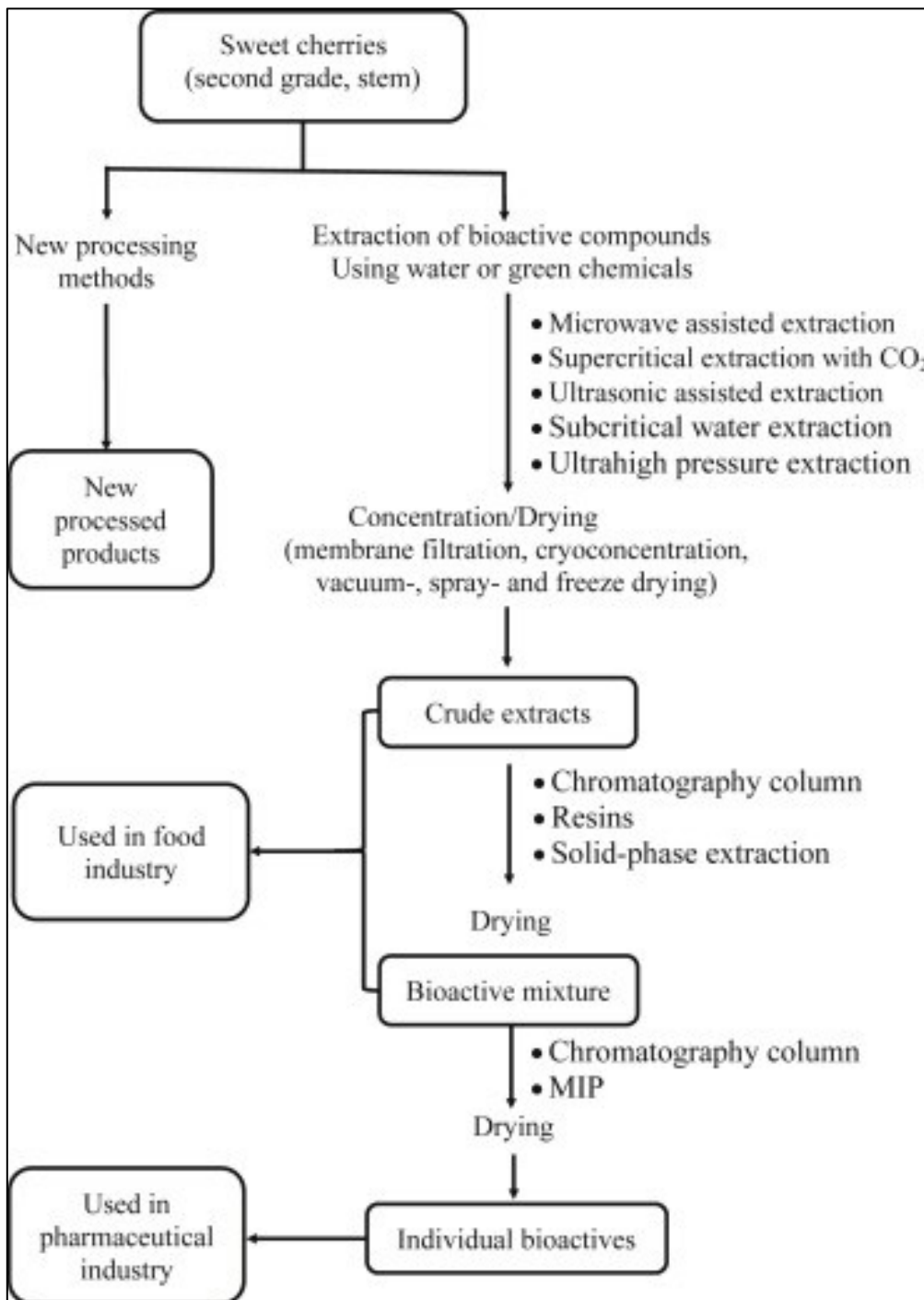

**Figure 7: Alternative uses of the sweet cherries.**

Source: Chockchaisawasdee et al. (2016)

To satisfy consumer demands of safe and sustainable foods, many technological solutions have been proposed such as edible coating based on biopolymers principally deriving from agriculture by-products. This new technology, indeed decrease the use of natural resource (e.g. fossil fuels), keep unchanged organoleptic and nutritional characteristics of food extending their shelf life. Therefore, thanks to these characteristics, edible coating can increase the profitability and competitiveness of the food industry on the global level. For instance, they allow to achieve new national and international position markets since they satisfy the customers' requests and prevent food wasting. For this latter reason, edible coating could contribute to perform the circular economy policy promote by European Commission since 2014 (European Union, 2014).

Indeed, as already mentioned this new technology that uses principally biopolymers obtained also from agriculture by-products (e.g. polysaccharides, protein or lipids) contributes to improve environmental and economic sustainability of food sector since it prevents waste disposal in landfill and promotes their reuse (Borrello et al., 2016). In this way, the companies move from a linear to circular economy system. Indeed, former system is related to negative environmental consequences: reserves depletion, climate change, loss of biodiversity and land degradation. These negative aspects contribute to higher resource price volatility, decreasing the economic growth and increasing uncertainty that can be overcome through the circular economy where waste from valueless products turn into a resource.

An example of circular economy potentially can be represented by edible coatings from agricultural by-products. Indeed, this sustainable source of edible packaging could represent a tool to defeat the competitors on the global markets, because helps enterprises to reduce the production cost and to respond the consumer demand of healthy and convenience foods. Edible coating and film, are packaging typology that preserved fruits keeping organoleptic and nutritional characteristics unaltered until consumption. This innovative technology has been studied for fresh sweet (*Prunus avium* L.), a fruit very appreciated by consumers, thanks its organoleptic, nutritional, and functional properties, that quickly degrading during transport and storage. (Tricase et al., 2017).

In this context, the present study aims to provide a comprehensive update overview on edible coatings and films of fruit and in particular of sweet cherries showing the opportunity for the food industry, environmental and customer protection.

Fresh fruit deteriorate rapidly after harvest and lose their quality in a short period of time ranging from several days to 1–2 weeks, depending on plant species and cultivar (Valero and Serrano, 2010). Low temperature storage is generally used to delay the postharvest deterioration process,

although in some cases this treatment is not enough to maintain fruit quality during handling, transport and commercialization. In this sense, additional postharvest tools together with cold storage are necessary. These tools can be represented, for instance, by edible coating a semi permeable barrier to protect food from physic-chemical and biological agents that reduce moisture loss, solute migration, respiration and oxidative reactions and retard the natural physiological ripening process (Vargas et al., 2008). One of the most important characteristics of these bio-based coatings is their edibility in other words they can be eaten as a part of the whole food product (Bourtoom, 2008).

In the recent years different typologies and applications coatings have been studied based on biodegradable polymers, often enriched with healthy component such as antioxidants and vitamins, that reduce the use of traditional material characterised by high pollution emission (e.g. fossil fuels). These can also improve safety aspect of fruit through adding natural antimicrobial agents to edible coating by particular processes such as “nano” encapsulation and the layer-by-layer assembly (Vargas et al., 2008). Moreover, since they could be produced using agricultural by-products edible coatings contribute to promote the circular economy policy. According to the European Commission (2014), this goal could be reached creating a network of enterprises in which by-products are used as inputs in a new production instead of disposal in land filled or directly in soil. In this way, it is possible to implement innovative business models (industrial symbiosis) that facilitate the clustering of activities, prevent that by-products becoming wastes (European Commission, 2014) and improves environmental performances of agro-food sector. Therefore, the development of new business opportunities to tackle environmental challenges (such as waste management) represents an important tool to get firms to work together in mutually beneficial ways.

An example of implementation of the industrial symbiosis and circular economy policy could be represented by the production of edible coating from agricultural by-product (Table 4).

For instance, cellulose can be extracted from a by-product of cotton supply chain (linter of cotton) to produce polysaccharide-based edible coating. Another example is glycerol an alcohol gets from biodiesel transesterification. Its production has increased in the last years causing an excess glycerol offers in the global market. Consequently, this has had impacted negatively on its price decreasing (Bagnato et al., 2017).

Therefore, one solution to increase economical value and expand the current glycerol market could be its utilization in edible-base coating industry. Moreover, thanks the low price of glycerol could

represent a viable solution to start production of edible coating on an industrial scale at reasonable prices.

Generally, the components used for produce edible films and coatings can be classified into following categories: polysaccharides, protein, lipid and composite (de Azeredo, 2012). They can be used individually or combined.

Polysaccharides are principally represented by starch (native and modified), cellulose, pectins, seaweed extracts (alginates, carrageenan, agar), various gums (exudate gums, microbial fermentation gums, acacia, tragacanth, guar) and chitosan (Bourtoom, 2008, Rojas-Graü et al., 2011).

In particular polysaccharides, being hydrophilic in nature can bind with functional additives such as flavours, colours, and micronutrients make the fruits more appreciated by consumers (Pascall and Lin, 2013). However, this type of coating does not protect fruit from moisture loose affecting their functional properties but provide a good barrier to CO<sub>2</sub> and O<sub>2</sub> exchange retarding respiration of fruits and consequently their ripening (de Azeredo, 2012). The edible coatings used for protecting fresh fruit are based on proteins that can generally are obtained from animal (e.g. casein and whey protein, collagen, gelatin, keratin) or plant sources (e.g. zein, wheat gluten, soy protein, peanut protein, corn-zein and cotton seed protein) (Dhall, 2013; Rojas-Graü et al., 2011).

These molecules thank to the hydrophilic characteristic formed a solid structure with good mechanical strength that can be used to reduce injuries of fruits during their transportation (Pascall and Lin, 2013). At the same time, this typology of edible coatings makes a good barrier to O<sub>2</sub> and CO<sub>2</sub> but not to water. Proteins can be obtained from different source such as calcium caseinate or whey giving interesting quality to edible coating like the retard of browning apples, enhance of plums appearance surface characterized by more glossy and improved firmness (de Azeredo, 2012). Although the use of protein from animal source coatings can increase the nutritional value of fresh fruits they can become less appealing to certain groups of consumers such as vegetarians, vegans or who is intolerant and/or allergic of these molecules (Rojas-Graü et al., 2011).

Another group of compounds use to produce edible coatings are lipids like monoglycerides, natural waxes and surfactants (Rojas-Graü et al., 2011). Generally, these substance coat are extracted from plants (e.g., carnauba, candelilla, and sugar cane waxes), minerals (e.g., paraffin and microcrystalline waxes), or animals including insects (e.g., beeswax, lanolin, and wool grease) (de Azeredo, 2012). Their functional proprieties depend on their chemical structure. For instance, if the edible coatings are composed by triglycerides with long-chain they are insoluble in water produced

a film that reduce fresh fruits respiration. They also prevent water loss and consequently retard softening of food products, extending its shelf life and improving their appearance. On the contrary the short-chain molecules are partially water soluble and consequently not efficient to preventing water loss. For these reasons lipid-base coating based on short-chain molecules are often supported on a polymer structure matrix, usually a polysaccharide, to improve the mechanical strength.

However, the coating obtains from saturated acetylated monoglycerides have a tendency to crack and flake during storage, accelerating the perishable of the fresh fruit (de Azeredo, 2012).

Edible coatings may be created blending the previous ingredients to form a structural matrix that combines some their useful properties to obtain an edible packaging with superior quality characteristics (Bourtoom, 2008). Therefore, this composite-base coating could be make either bilayers or stable emulsions mixing proteins with carbohydrates or lipids, carbohydrates with lipids, synthetic polymers or natural polymers.

These blends improve the permeability or mechanical properties of fruit for instance adding a double layer of lipids and gluten on strawberries it can be reduced their softening and weight.

However, this blend can decrease these advantages since lipids decrease the permeability of water increasing the perishable and reduce their flavor and appearance (de Azeredo, 2012). Moreover, to enhance the characteristics of the edible coatings (e.g. mechanical properties and flexibility) some plasticizers are added such as glycerol, polyethylene glycol, or sorbitol, may be added to modify film/coating. (Rojas-Graü et al., 2011). Scientific research is in ferment on this topic, but in this study, it was not deepened. It is outside of the CF assessment of sweet cherry, but it has been considered, to have a complete picture of the supply chain.

**Table 4: Components, origin and effect on products of edible coatings and films**

Comp.	Substances	Origin	Fruit	Effect on Product
<b>Polysaccharide</b>	Cellulose	Cotton	Cherry Apple Pear Grapes	Reducing water loss, decrease the acidity, delayed browning, extend shelf-life, slow down weight losses and control the oxygen consumption respectively
	Plant gel	<i>Aloe vera</i>	Cherry Apple Grapes	Prevent moisture loss and firmness, reduce microorganism proliferation, weight loss, colour changes, softening, ripening, browning and extend the storage life respectively.
	Chitosan	Crab and shrimp shells	Pear Pistachio Nuts Strawberry	Reduce and prevent microbial growth and extend shelf life respectively
	Starch	Cereals, legumes, and tubers	Strawberry	Reduce moulds and yeast
	Alginate, gellan	Seaweed	Pear	Prevent browning
<b>Protein</b>	Zeina	Corn	Cherry	Accelerate ripening
	Gelatine film	Collagen	Cherry	Lowest moisture loss
	Soy protein isolate	Soy	Cherry	Decrease the acidity
	Casein proteins	Milk	Zucchini	Reduce water loss
	Calcium caseinate and whey protein	Milk	Apple	Delay browning
<b>Lipid</b>	Plant Wax	<i>Euphorbia antisyphilitica</i>	Apple	Prolongs and improves the shelf life, excellent antifungal barrier and slow weight loss
<b>Composite</b>	Lemongrass + oregano oil + vanillin + alginate	Plants + Seaweed	Apple	Reduce moulds and yeast
	Cinnamon + clove + lemongrass essential oils (Eos) + alginate	Plants + Seaweed	Apple	Maintain the physicochemical characteristics, decreased the respiration rate, extended the shelf life and increased its antimicrobial effect
	Carrageenan + whey protein concentrate	Red seaweed + milk	Apple	Maintain the original colour during storage without changes in sensory properties
	Whey protein concentrate + beeswax	Milk + insects	Apple	Reduce surface browning
	Galactomannans and collagen blends	Leguminous seeds + animal	Apple	Lower the CO <sub>2</sub> production and the O <sub>2</sub> consumption by approximately 50%
	Beeswax and fat	Insects and animals	Citrus	Retard water loss and prevent desiccation
	Wax and oil	Plants	Apple	Extend the shelf life
	Paraffin carnauba + Beeswax soybean oil + Cellulose	Insects + Plants	Apple	Decrease soluble solids, titratable acidity and ascorbic acid loss; increase storage life
	Oil + starch	Plants	Pomegranate	Reduced softening of arils, weight loss and % of browning index, loss of vitamin C, loss of anthocyanin and delayed microbial decay
	Whey protein isolate + Pea starch (PS) + Carnauba wax	Plants+Animals	Walnuts and Pine nuts	Prevent oxidative and hydrolytic rancidity, improve their smoothness, taste and improved sensory characteristics
Semperfresh™	Commercial product based on vegetable oils and plant cellulose	Apple	Reduce colour changes, retain acid, extend shelf life, and maintain quality	

Source: adapted from Mellinas et al. (2016); Kore et al. (2017); Rojas-Graü et al. (2011); Martinez-Romero et al. (2006)



Sweet cherries (*Prunus avium L.*) are a very appreciated fruit, thanks their organoleptic, nutritional, and functional properties, and have steadily become more popular among consumers worldwide. Indeed, this fruit is highly demanded by the global market and Italy is the fourth top world cherries producer with 111 kt in 2014 after Turkey, United States of America and Iran (Islam Republic of) (FAOSTAT, 2017). The Apulia region is the largest sweet cherries producer at the national level representing 35% of the total domestic in 2015. For this reason, sweet cherry represents an important product and economic driver that contributes to increase the revenue of agriculture sector of this territory (Tricase et al., 2017).

However sweet cherry is highly perishable fruit with a short shelf life and high respiration rates. These aspects lead to quality loss of these fruits before reaching consumers. So, to prevent losses of harvest and avoid that the fruit quality declines below market standards sweet cherries must be commercialised expedite and sold at a low price (Aday and Caner, 2010). Therefore, strategies need to be developed to overcome these hurdles. A possible solution is represented by the edible coating a technology that can contribute to preserve the quality of sweet cherries, to extend their shelf life and to make more attractive for consumers (Mahfoudhi and Hamdi, 2015). Currently edible coating is in experimental phase and researchers are studying the effectiveness of various biopolymers tested during the post-harvest ripening phase of sweet cherry. For instance, sodium alginate coating delays its browning, softening, acidity and reduces the respiration rate. Moreover, it is effective in to keep unchanged the total amount of phenolic compounds and the antioxidant activity maintaining unaltered quality of the coated fruits for more time than the conventional packaging. (Díaz-Mula et al., 2012). Also, proteins, chitosan, shellac, Arabic gum and almond gum, used as edible coatings, show positive effects on the reduction of respiration rate and the ethylene production extending the shelf life (Aday and Caner, 2010; Dang et al., 2010, Mahfoudhi et. al., 2014, Mahfoudhi and Hamdi, 2015). The latter characteristic represents one of the main goal of the food sector and in particular of sweet cherry production since it allows to improve yield and to accelerate sweet cherry market expansion and consequently increase the revenue of farmers. For this reason, further research is need to allow their application at industrial scale level evaluating not only the technical aspects but also the environmental, social and economic. On the other hand, use of this edible-based coating need further studies since some problems are still unsolved such us flavour alteration of fruit, a scarce protection against external agents (e.g. bacteria, fungi, oxygen, etc.) and the presences of potential allergens in edible and film coatings.

## 1.4 Sweet cherry's market: economic aspects<sup>1</sup>

Sweet cherry is a fleshy non-climacteric stone fruit belonging to the genus *Prunus* and is mainly grown in countries, more than 40, under a temperate climate. Thanks to the organoleptic characteristics (i.e. taste, sweetness and colour) as well as the natural presence of nutrients, antioxidants and other healthy compounds such as (i.e. flavonoids, vitamins, anthocyanins and phenolic) cherry is one of the most appreciated fruits worldwide. Moreover, as so many other fruit, fresh cherries are currently marketed as such or processed into several derivatives like, for instance, jam, juice and yogurt: this makes them highly appreciated by consumers (Wani et al., 2014). Moreover, in the last 20 years the introduction of new varieties and the technological improvement (to protect crops from frost, hail and cracking) have contributed to increase the yield from 5.24 t/ha in the late 90's to 5.58 t/ha in the last ten years.

Cherries, ready for the fresh market, must comply with the EU and International marketing standards quality. The sweet cherry commercialization is covered by the United Nations Economic Commission for Europe (UNECE) standard and by the Commission Regulation (EC) No 214/2004 of 6 February 2004. The latter was updated with the Commission Regulation (EC) No 543/2011 that contain main changes regarding the definition of “sound, fair and of marketable quality” (general marketing standard for fresh produce); fewer specific marketing standards (10 instead of 36) and simplified and rationalised checking operations. Moreover, to harmonise the application and interpretation of these international Fruit and Vegetable (F&F) standards the Organisation for Economic Cooperation and Development (OECD) published brochure scheme which facilitate international trade through the simplification of procedures. This scheme is an interpretative “brochures” of UNECE quality standards. In fact, it comprises explanatory notes and illustrations to facilitate the uniform interpretation of the Cherries Standard. This brochure illustrates the standard text and demonstrates the quality parameters on high quality photographs.

These international standards are developed to remove products of unsatisfactory quality from the market, bring production into line with consumer requirements and facilitate trade based on fair competition, thereby helping to improve profitability (UNECE Standard FFV-13, 2017; EC, 214/2004). As regard the provisions concerning quality, the standards define the quality requirements for cherries, after preparation and packaging, that must be:

---

<sup>1</sup>This part is already published in Tricase, C., Rana, R., Andriano, A. M. and Ingraio, C., 2017. An input flow analysis for improved environmental sustainability and management of cherry orchards: A case study in the Apulia region. *Journal of Cleaner Production*. 156, 766-774. DOI: 10.1016/j.jclepro.2017.04.088.

- intact;
- fresh in appearance;
- sound; produce affected by rotting or deterioration such as to make it unfit for consumption is excluded;
- firm (according to the variety);
- clean, practically free of any visible foreign matter;
- practically free from pests;
- practically free from damage caused by pests;
- free from abnormal external moisture;
- free of any foreign smell and/or taste;
- with the stem attached<sup>2</sup>.

The development and condition of the cherries must be such as to enable them:

- to withstand transportation and handling;
- to arrive in satisfactory condition at the place of destination.

Furthermore, according to international standards (UNECE Standard FFV-13, 2017), cherries are classified into the follow three classes:

1. “Extra” Class: cherries must be of superior quality and must be free from defects with the exception of very slight superficial skin defects;
2. Class I: cherries must be of good quality. It is allowed slight defects provided these do not affect the general appearance of the produce, the quality, the keeping quality and presentation in the package;
3. Class II: cherries which do not qualify for inclusion in the higher classes, but satisfy the minimum requirements specified above.

Moreover, size is determined by the maximum diameter of the equatorial section. Cherries must have minimum sizes for “Extra” Class 20 mm and for Classes I and II 17 mm (UNECE Standard FFV-13, 2017).

At all marketing stages, tolerances in respect of quality and size shall be allowed in each lot for produce not satisfying the requirements of the class indicated. In particular:

- “Extra” Class: A total tolerance of 5 per cent, by number or weight, of cherries not satisfying the requirements of the class but meeting those of Class I is allowed. Within this

---

<sup>2</sup> According to Commission Regulation (EC) No 214/2004, missing stems are allowed provided the skin is not damaged and there is no severe leakage of juice in the case of sour cherries and cherries of the type ‘Picota’ or equivalent denominations, which naturally lose the stem at harvest.

tolerance not more than 0.5 per cent in total may consist of produce satisfying the requirements of Class II quality, and not more than 2 per cent may consist of split and/or worm-eaten fruit.

- Class I: A total tolerance of 10 per cent, by number or weight, of cherries not satisfying the requirements of the class but meeting those of Class II is allowed. Within this tolerance not more than 1 per cent in total may consist of produce satisfying neither the requirements of Class II quality nor the minimum requirements, or of produce affected by decay, and not more than 4 per cent may consist of split and/or worm-eaten fruit.
- Class II: A total tolerance of 10 per cent, by number or weight, of cherries satisfying neither the requirements of the class nor the minimum requirements are allowed. Within this tolerance, not more than 4 per cent in total may consist of over-ripe, split, or worm-eaten fruit or of produce affected by decay.

For all classes: a total tolerance of 10 per cent, by number or weight, of cherries not satisfying the requirements as regards sizing is allowed.

As regard the provisions concerning marking each package must bear the following particulars, in letters grouped on the same side, legibly and indelibly marked, and visible from the outside. It is important specify:

- Identification: Name and physical address or a code mark officially recognized by the national authority.
- Nature of produce: cherries if the contents are not visible from the outside, “stemless” cherries or equivalent denomination, where appropriate and the name of the variety (optional).
- Origin of the produce: country of origin
- Commercial specifications: class.

The purpose of these standards is to remove products of unsatisfactory quality from the market, bring production into line with consumer requirements and facilitate trade based on fair competition, thereby helping to improve profitability (UNECE Standard FFV-13, 2017; EC, 214/2004).

Fresh cherries are highly demanded by the global market: as a matter of fact, over the last twenty years (1993–2013) the global production has increased by almost 35% compared to the value recorded in 1993 (1.702 Mt) (see Figure 9) (FAOSTAT, 2015).

As shown Figure 9, the major cherry-producing countries are Turkey (600 kt), United States of America (USA) (288 kt), Iran (Islam Republic of) (220 kt), Italy (95 kt) and Spain (94 kt). Turkey is the unquestioned global market leader doubling, over the last twenty years, the surface invested for cultivation. Additionally, USA was increased its production due to the recent investments in genetic improvement of rootstocks, new cultivars and technologies for preventing adverse weather conditions (Valkanov, 2015; UNCTSD, 2016). Moreover, although the cherry production trend of single countries has increased during the last two decades, a fluctuant behaviour was observed mainly due to physiological alternation of production, weather conditions and parasite attacks that contribute to variation of cherries yield.

Cherry is well established in Italy thanks to the soil and climate conditions, and the recognised experience and professionalism of producers. The technological improvements as well as the establishment of new cultivars made it possible for cherry production to level out at 120,000 t (FAOSTAT, 2015) in 2015, so contributing to the promotion a future positive trend. However, the total cherry production in the last year is decreased due to unfavourable weather conditions.

As regards the import/export system, in 2015 Italy exported 10,837 t of cherries, mainly for Germany (51% of the total exported) followed by Switzerland (8%), Austria (7%) and United Kingdom (6%) (Figure 8). Conversely, Italy imported 8,844 t in the same year, mainly from Spain (4,600 t) and, Turkey (1,488 t).

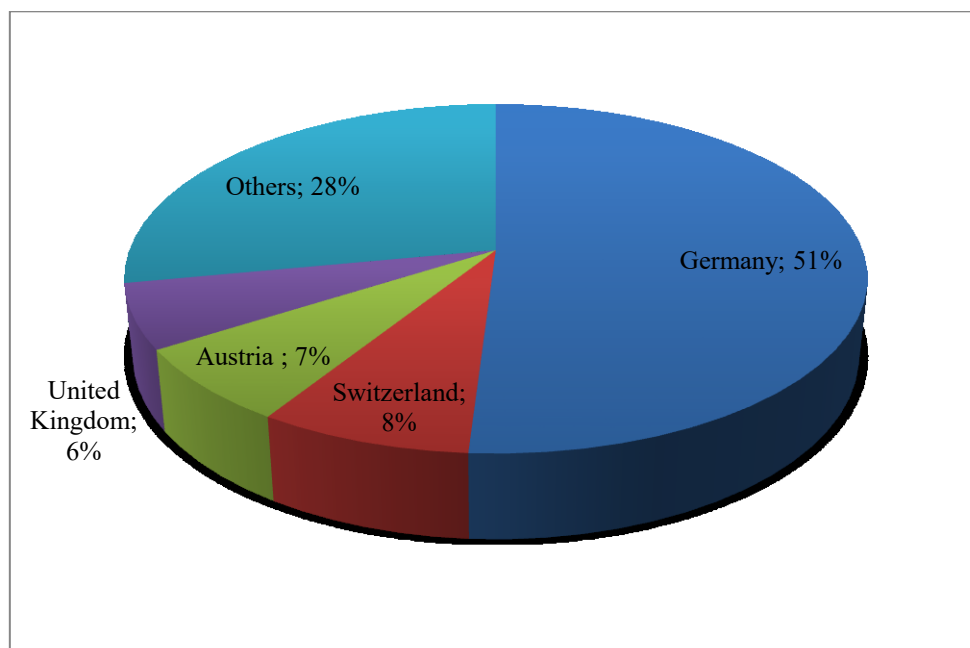

**Figure 8: Importing countries of Italy**

Source: (UNCTSD, 2016)

As shown Figure 10, Apulia is the biggest cherry producer in Italy representing almost 32% of the total domestic 2015-production followed by Campania (24%), Veneto (11.88%) and Emilia-Romagna (11.63%): the other national regions contribute in total for the remaining 20% (Agri-ISTAT, 2015).

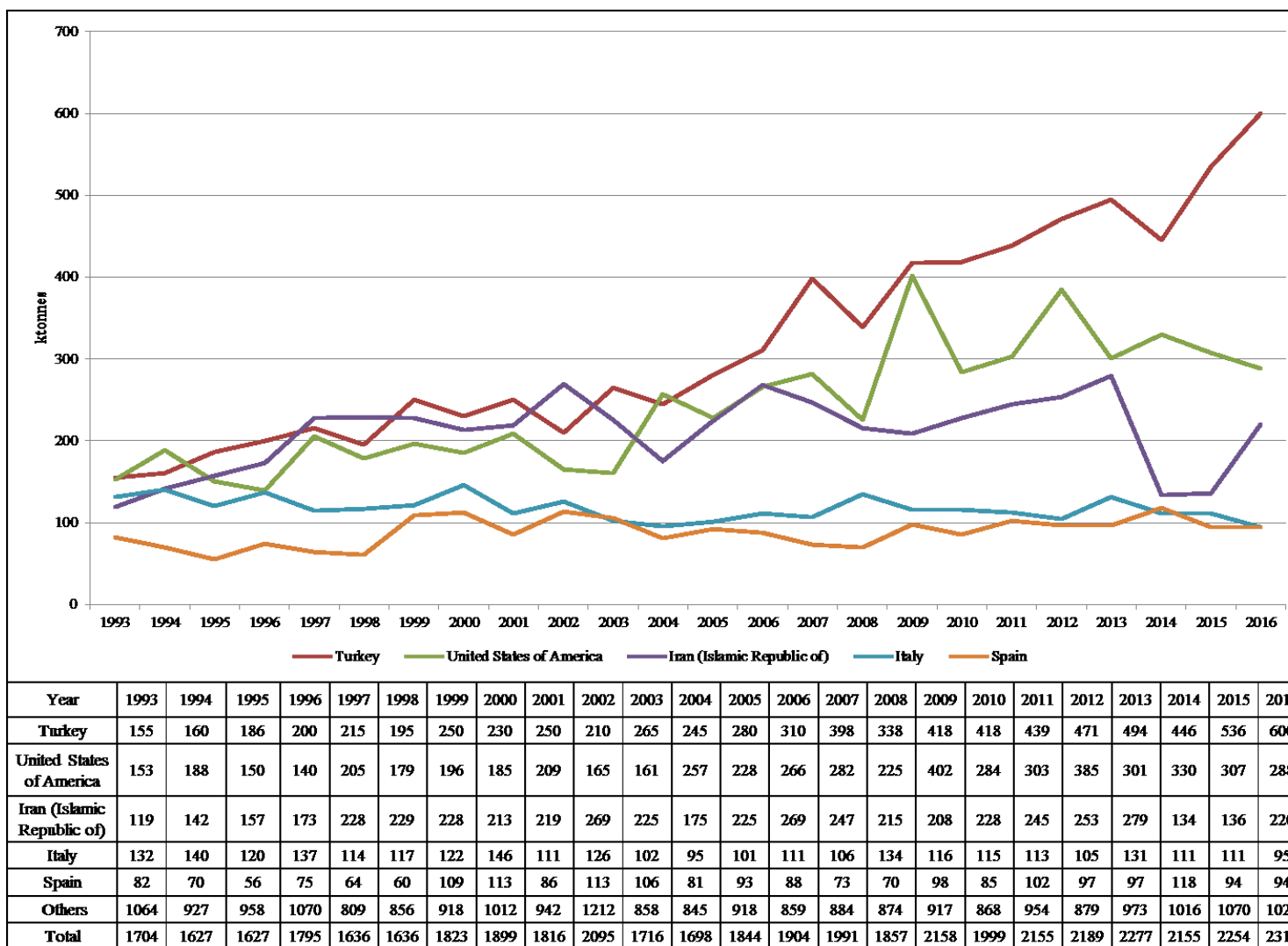
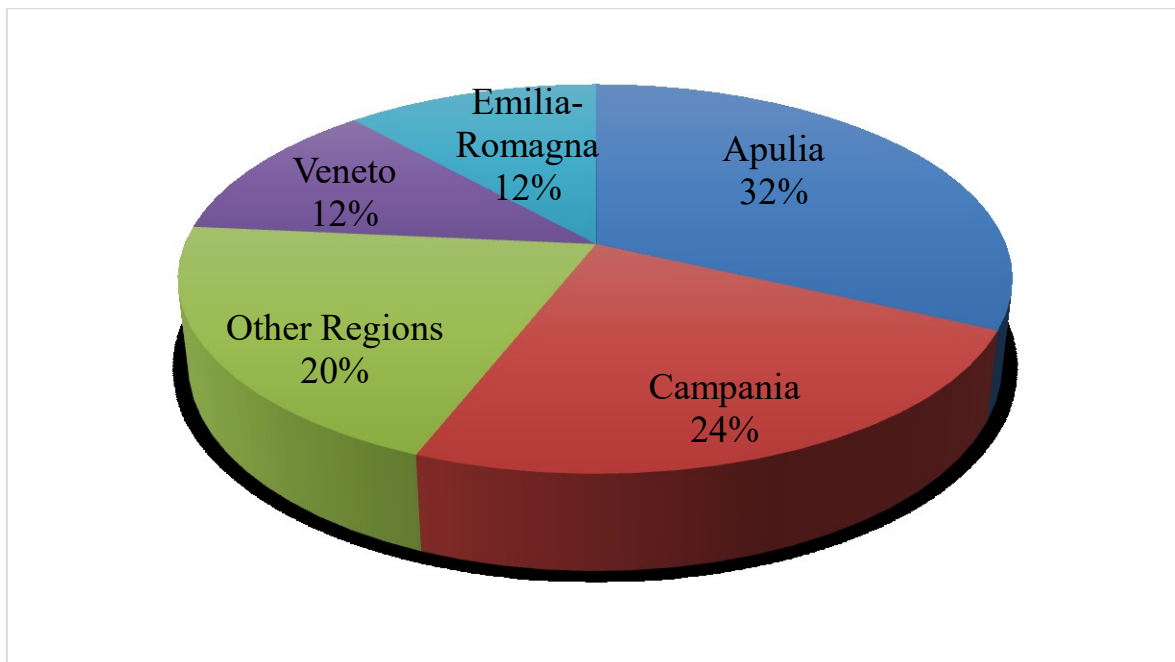

Figure 9: World production of cherries (values in kt)

Source: FAOSTAT, 2015



**Figure 10: Production of cherries in Italian region in 2015**

Source: (Agri-ISTAT, 2015)

In particular, in Apulia the greatest production areas are located in the districts of Bari and Barletta-Andria-Trani (BAT). As evident from Table 6, in 2017 the two districts are characterised by a cherry production that represents the 84% and 9% of the regional total. Also, the surfaces invested for cherry cultivation represent the 92% and 4.3% of the related total values.

In these areas, cherry production represents an important product that contributes to increase the revenue of the Region. Amongst the different varieties cultivated, that named as “Ferrovia” represents one of the most appreciated and exported fruit thanks to its compact flesh that, apart from the good taste, allows an easy transport to long distance. It is estimated, indeed, that only 10% of the Apulia cherry production is destined to the local market whilst the remaining 90% reach the markets of northern Italy and Europe (AA.VV., 2009).

Finally, from the analysis of the cherry supply chain currently developed in the Region it was observed that there exists a clear separation between producers and retailers that, as a consequence, weighs down the management of the whole chain itself. Hence, there would be the need for creation of a one system where all the operators involved in the supply chain are interconnected such as, for instance, a specific "web platforms" (Guglielmi et al., 2014), where to find all information necessary for all stakeholders of the cherry supply chain. In this way, it can be facilitated both the



matching between demand and supply and the products transfer from producers to retailers, improving the whole supply chain management.

**Table 5: Cherries production and cultivated area in Apulia districts**

Year		Districts						Apulia
		Foggia	Bari	Taranto	Brindisi	Lecce	BAT*	
2006	Prod. (t)	385	30,060	945	2,250	240	-	<b>33,664</b>
	<i>Cult. area (ha)</i>	<i>120</i>	<i>17,000</i>	<i>110</i>	<i>250</i>	<i>6</i>	<i>-</i>	<b>17,486</b>
2007	Prod. (t)	480	30,060	200	1,750	240	-	<b>32,514</b>
	<i>Cult. area (ha)</i>	<i>120</i>	<i>17,000</i>	<i>110</i>	<i>250</i>	<i>6</i>	<i>-</i>	<b>17,176</b>
2008	Prod. (t)	480	67,400	945	1,625	30	-	<b>70,480</b>
	<i>Cult. area (ha)</i>	<i>120</i>	<i>17,000</i>	<i>110</i>	<i>250</i>	<i>6</i>	<i>-</i>	<b>17,486</b>
2009	Prod. (t)	480	50,100	73,5	1,250	18	-	<b>52,583</b>
	<i>Cult. area (ha)</i>	<i>120</i>	<i>17,100</i>	<i>110</i>	<i>250</i>	<i>6</i>	<i>-</i>	<b>17,586</b>
2010	Prod. (t)	480	48,000	800	700	17	2,040	<b>52,037</b>
	<i>Cult. area (ha)</i>	<i>120</i>	<i>16,700</i>	<i>110</i>	<i>250</i>	<i>6</i>	<i>680</i>	<b>17,886</b>
2011	Prod. (t)	450	38,000	600	2,000	18	1,904	<b>42,972</b>
	<i>Cult. area (ha)</i>	<i>120</i>	<i>16,800</i>	<i>105</i>	<i>260</i>	<i>5</i>	<i>720</i>	<b>18,010</b>
2012	Prod. (t)	490	24,000	1,575	1,800	15	2,000	<b>39,880</b>
	<i>Cult. area (ha)</i>	<i>120</i>	<i>16,500</i>	<i>350</i>	<i>260</i>	<i>5</i>	<i>780</i>	<b>18,015</b>
2013	Prod. (t)	600	55,000	1,280	1,300	13	2,850	<b>61,043</b>
	<i>Cult. area (ha)</i>	<i>150</i>	<i>17,100</i>	<i>320</i>	<i>260</i>	<i>5</i>	<i>780</i>	<b>18,615</b>
2014	Prod. (t)	550	33,620	1,260	1,170	12	1,540	<b>38,152</b>
	<i>Cult. area (ha)</i>	<i>150</i>	<i>17,000</i>	<i>280</i>	<i>260</i>	<i>10</i>	<i>800</i>	<b>18,500</b>
2015	Prod. (t)	600	35,000	1,120	1,450	20	2,600	<b>40,790</b>
	<i>Cult. area (ha)</i>	<i>150</i>	<i>17,200</i>	<i>280</i>	<i>260</i>	<i>10</i>	<i>800</i>	<b>18,700</b>
2016	Prod. (t)	450	28,000	700	1,100	18	2,500	<b>32,768</b>
	<i>Cult. area (ha)</i>	<i>150</i>	<i>17,100</i>	<i>290</i>	<i>260</i>	<i>9</i>	<i>800</i>	<b>18,609</b>
2017	Prod. (t)	600	39,000	1,260	1,300	15,5	4,000	<b>46,175</b>
	<i>Cult. area (ha)</i>	<i>150</i>	<i>17,100</i>	<i>290</i>	<i>260</i>	<i>9</i>	<i>800</i>	<b>18,609</b>

\* The BAT district has become functioning in 2009, therefore the statistical data collection started from 2010

Source: (Agri-ISTAT, 2015)

## **SUSTAINABILITY OF THE SWEET CHERRY SUPPLY CHAIN: A CASE STUDY**

The European Union (EU) has set target to reduce Greenhouse Gas (GHG) emissions progressively to promote a low-carbon economy. In October 2014, the European Council published the 2030 climate and energy framework, a set of binding legislation to ensure that the EU States meet the following climate and energy targets: 40% cuts in greenhouse gas emissions (from 1990 levels); 27% of EU Energy comes from renewable sources and 27% improvement in energy efficiency. To reach these targets, the EU is taking action in several economics sectors such as the agriculture. (European Commission, 2017a, b). In this regard the EU's has reformed Common Agricultural Policy (CAP) to support sustainable farming practices less impacting on climate change. In fact, CAP considers that 30% of the payments going directly to farmers which implement practices such as GHG emissions reduction (European Commission, 2017c). Furthermore, CAP promote and support enterprise that invest in innovation/internationalization improving environmental sustainability and increasing productivity and efficiency. In addition to CAP other types of European tools has been implemented to facilitate the innovation in the agricultural sector, such as the European rural development policy, the EU research and innovation program (Horizon 2020) and the European Innovation Partnership 'Agricultural Productivity and Sustainability' (EIP). In particular these projects aim to implement the sustainable agriculture in terms of: a) economic, to guarantee a profitability to the farmers and rural communities; b) social, to meet the expectations of citizens (i.e. employment increase); c) and environmental, to avoid natural resources depletion and climate change Specially, environmental sustainability actions are desirable also because they meet consumers request that currently have increased awareness of the importance of healthy and safe nutrition and food production with low environmental impact (Burt, 2004; Johnston et al., 2014).

As a consequence, to support those actions it is needed to develop environmental assessment that provide useful information deriving from data inventoried, methodologies applied and results gathered in the food sector (European Commission, 2015). In this context, the Apulia region, a territory with a high bent fruit production, has developed and approved the Rural Development Programme (RDP) (Italy - Rural Development Programme (Regional) – Puglia, 2017), that contains the environmental protection objectives in the agro-food sector, according to the aforementioned rules proposed by the European Union, for underpin the local agricultural economy. The Apulia

RDP provides to strengthens tools to improve competitiveness (aggregation, quality, risk management) and environmental sustainability of the agricultural sector. In particular, the Apulia RDP contributes to tackle climate change problems through agricultural practices that: a) encourage GHG emissions reduction and carbon sequestration; b) increase the natural soil absorption capacity; c) and decrease the use of nitrogen fertilizers. To apply these practices, it is important to implement scientific studies that help the farmers to find and/or to improve sustainable solutions for agricultural productions. For instance, although sweet cherry represents an important agricultural product in Apulia Region, according to Tricase et al. (2017) there are few works on environmental assessment (such as Carbon Footprint – CF) that encourage the farmers towards sustainable practices (European Commission, 2017c). As regard the production of this fruit, Italy is the fourth top world cherries producer (117 kt in 2014) after Turkey, United States of America and Iran (Islam Republic of) (FAOSTAT, 2017). The Apulia region is the largest sweet cherries producer at the national level with 32% of the total domestic in 2017 (Agri-ISTAT, 20017). For this reason, sweet cherry represents an important product and economic driver that contributes to increase the revenue of agriculture sector of this territory (Tricase et al., 2017). The research was divided into two parts. The first is focussed upon study setting, that includes definition of objectives, functional unit and system boundaries, and both collection and analysis of the inventory data, whilst the second regards GWP<sub>100</sub> assessment. Therefore, it is believed that the present thesis can contribute firstly to enrich the international knowledge on the environmental burdens associated with sweet cherry supply chain and secondly to support farmers to employ sustainable tools for this production. These aspects represent an innovation in sweet cherry supply chain.

## **2.1 Carbon Footprint: principal aspects of ISO/TS 14067:2013**

Currently the awareness of environmental, territorial and social functions of agriculture is increased. The growing attention of consumers for sustainable, safety and health food represent an incentive to produce goods that respect environment and ethic aspects and consumer requests. Climate change is a top priority among environmental challenges that must be addressed at all levels of society.

Greenhouse gases (GHG) emission<sup>3</sup> in atmosphere are responsible to the global warming and to the resulting tragic climate changes. For these reasons, it is important identify solutions to confront these problems. Different initiatives are being developed and implemented to limit GHGs concentrations. Some of these are based on the assessment, monitoring, reporting and verification of GHG emissions and/or removals.

In this context, carbon footprint is used as an indicator to quantify and manage emission of GHGs and to further minimise their potential sources by identifying appropriate improvement solutions.

Despite the widespread use, a widely accepted definition of a "carbon footprint" does not exist at present. According to the most widespread definition of Joint Research Centre (JRC) for Carbon Footprint (CF) it intends: "the overall amount of carbon dioxide (CO<sub>2</sub>) and other GHG emissions (CH<sub>4</sub>, N<sub>2</sub>O, HFCs, etc.) associated with a product (goods and services) along its supply-chain and sometimes including from use and end-of-life recovery and disposal".

To quantify the carbon footprint is used the Global Warming Potential (GWP). The latter is a coefficient and is defined by the Intergovernmental Panel on Climate Change (IPCC), the primary authority on climate change, as an indicator that reflects the relative effect of a GHG in terms of climate change considering a time period of 20, 100, and 500 years. Such releases are all expressed in terms of carbon dioxide equivalent<sup>4</sup> (CO<sub>2eq</sub>) and indicates the potential climate change effect per kg of a GHG over a fixed period (e.g. 100 years) (IPCC, 2007).

The total of the GWPs for different emissions gives one single indicator that expresses the overall contribution to climate change of these emissions. In the time, the IPCC has published several reports where has update the GWP value (table 7).

**Table 6: GWP<sub>100</sub> per kg emission (kg CO<sub>2eq</sub>/kg GHG)**

GHG	Second Assessment Report (IPCC, 1995)	Third Assessment Report (IPCC, 2001)	Fourth Assessment Report (IPCC, 2007)	Fifth Assessment Report (IPCC, 2013)
Carbon dioxide (CO <sub>2</sub> )	1	1	1	1
Methane	21	23	25	28
Nitrous oxide (N <sub>2</sub> O)	310	296	298	265
Hydro-fluorocarbons	140-11,700	12-12,000	124-14,800	<1 - 12,400
Per-fluorocarbons	6,500-9,200	5,700-11,900	7,390-12,200	<1 - 11100
Sulphurhexafluoride	23,900	22,200	22,800	23,500

(Source: <http://www.ipcc.ch>)

<sup>3</sup> GHG emission: mass of a greenhouse gas released to the atmosphere (ISO 14067:2013)

<sup>4</sup> CO<sub>2eq</sub> is a unit for comparing the radiative forcing of a greenhouse gas to that of carbon dioxide (ISO 14067:2013)

The principal global standards and guidance specifications focussing on carbon footprint assessment are:

- Greenhouse Gas (GHG) Protocol, from the World Resource Institute (WRI) and the World Business Council on Sustainable Development (WBCSD), was published for the first time in 1998. GHG Protocol is a measuring tool used by organizations, governments and businesses to GHG emission accounting. At present, exist four standards released by GHG Protocol that define the guidance how GHG emissions inventories should be performed at enterprise (*Corporate Accounting and Reporting Standard* – “Corporate Standard” and *The Corporate Value Chain (Scope 3) Accounting and Reporting Standard* – “Scope 3 Standard”), project (*Project Protocol*), and product (*Product Life Cycle Accounting and Reporting Standard* - “Product Standard”) levels.

For GHG accounting and reporting objectives are specified three scopes (1, 2 and 3, Figure 11):

- Scope 1- Direct GHG emission: occur from sources that are owned or controlled by the reporting company;
- Scope 2 – Electricity indirect GHG emission: are emissions that are a consequence of the activities of the reporting company, but derive from sources owned or controlled by another company (e.g. purchased electricity);
- Scope 3 – Other indirect GHG emission: are all the other indirect emissions (e.g. transportation of purchased fuels) that occur in a company’s value chain.

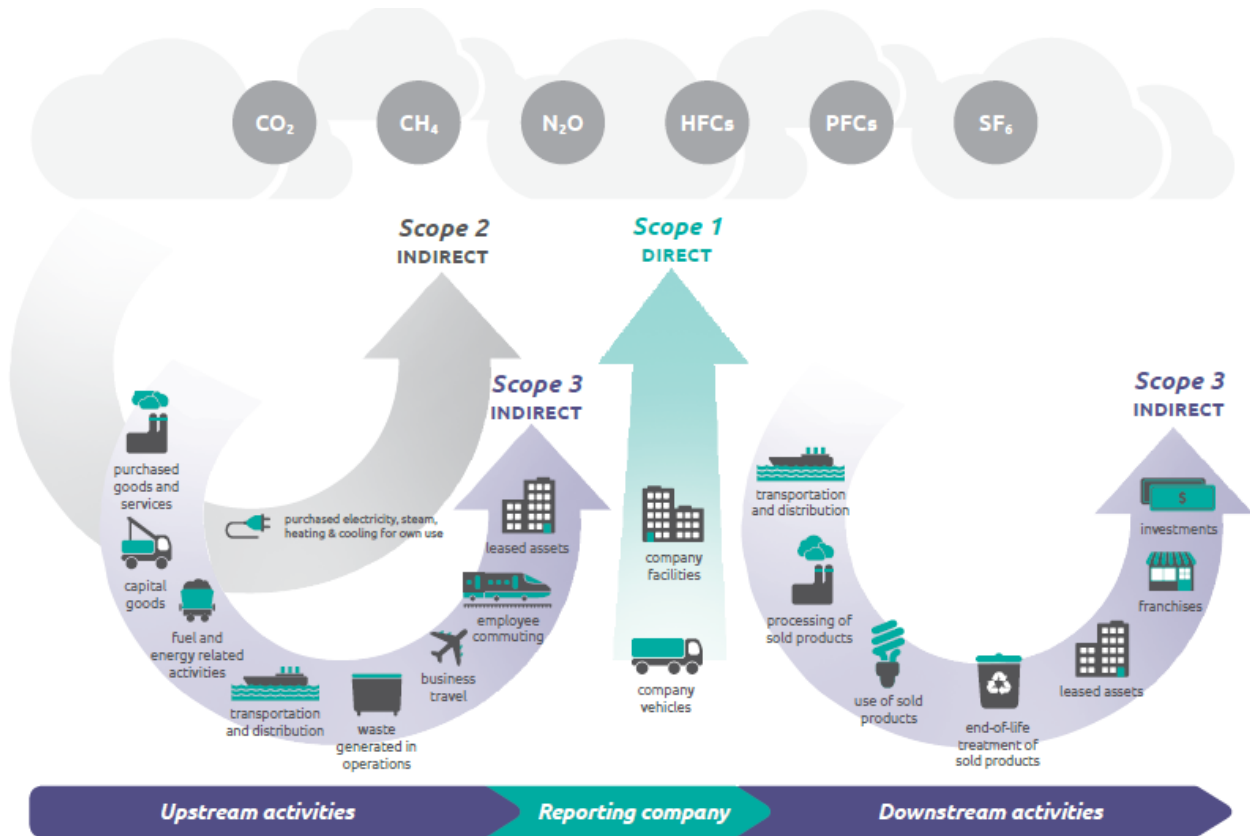

**Figure 11:** Overview of GHG Protocol scopes and emissions  
(Source: WRI and WBCSD, 2011)

- Publicly Available Specifications (PAS) 2050, from the British Standard Institution: was first published in 2008 (BSI, 2008) and was revised in 2011 (BSI, 2011), in line with GHG Protocol Product Standard (WRI and WBCSD, 2011) concerning key topic such as sector/product rules, biogenic carbon, recycling, land-use change, delayed emissions).
- ISO/TS 14067: 2013 (ISO/TS, 2013), from International Organization for Standardization a worldwide federation of national standards bodies (ISO member bodies), provides specific principles, requirements and guidelines for the quantification and communication of the CF of products (CFPs), including both goods and services, based on GHG emissions and removals over the life cycle of a product. This Technical Specification including also the requirements and guidelines for the quantification and communication of a partial carbon footprint of products (partial CFP) (ISO/TS 14067: 2013).

PAS 2050 and ISO/TS 14067:2013 are based on the international standards for LCA studies. In particular for PAS 2050 is based on ISO 14040:2006 and ISO 14044:2006 and ISO 14025:2006.

Whereas ISO/TS 14067:2013 is based on ISO 14020:2000, ISO 14024:1999, ISO 14025:2006, ISO 14040:2006 and ISO 14044:2006.

In meantime, a national GHG accounting guidelines have been developed in various countries such as in United Kingdom the Department of Food and Rural Affair (DEFRA) and the Carbon trust, in United State of America the Environmental Protection Agency (EPA), in Japan the Trade and Industry (METI), in Korea the Product Based Reduction Scheme and the European Commission Project on “carbon footprint measurement toolkit” for the European Union Ecolabel (Pandey et al., 2011).

The existence of a globalized market requires the creation and diffusion of one international standard of reference that is worldwide recognize. For this reason, in 2013, ISO 14067 was issued, which aims to improve the clarity and consistency of the Carbon Footprint (CFP) Quantification, Reporting and Communication activities. ISO 14067:2013 defines the principles, requirements and guidelines for quantification and communication of the CFP, based on:

- for quantification, on the international standards for LCA studies:
  - ISO 14040:2006, Environmental management — Life cycle assessment — Principles and framework;
  - ISO 14044:2006, Environmental management — Life cycle assessment — Requirements and guidelines); and
- for communication, on environmental labels and declarations:
  - ISO 14020:2000, Environmental labels and declarations — General principles;
  - ISO 14024:1999, Environmental labels and declarations — Type I environmental labelling — Principles and procedures;
  - ISO 14025:2006, Environmental labels and declarations — Type III environmental declarations — Principles and procedures.

Moreover, this Technical Specification is applicable also for a partial carbon footprint of a product (partial CFP) and also for CFP-product category rules (CFP-PCR), or the adoption of product category rules (PCR) that have been developed in accordance with ISO 14025.

The only impact category that addresses the ISO 14067 is that of the climate change.

ISO 14067 defined CFP as the *sum of GHG emissions<sup>5</sup> and removals in a product<sup>6</sup> system, expressed as CO<sub>2eq</sub><sup>7</sup> and based on a life cycle assessment using the single impact category of climate change* (ISO 14067:2013).

---

<sup>5</sup> GHG emission is a mass greenhouse gas released to the atmosphere (ISO 14067:2013)

According to the recommendations of the International Standards (ISO, 2006a,b), the implementation of this methodology based on LCA approach includes the following four phase:

- Goal and Scope definition;
- Life Cycle Inventory (LCI);
- Life Cycle Impact Assessment (LCIA);
- Life Cycle Interpretation.

On based of this framework was implemented the aims of this research.

Since a few CF studies focused on sweet cherry supply chain (Demircan et al., 2006, Kizilaslan, 2009, Litskas et al., 2011, Bravo et al., 2017 and Tricase et al., 2017), the present study has extended an overview of CF also of fruit trees (i.e. sweet cherry, peach, nectarine, banana, pomegranate, orange, kiwi etc). The revision has highlighted some aspect very important to consider to an accurate application of the methodology. First of all, it is a confusion of the definition of CF, because when they have used the search engine with keywords the most of sources have discussed on LCA and not on CF. It should be known that CF is a methodology based on LCA approach.

In the vast majority of the reviewed papers, very little attention was paid on some key parameters such as the immature and unproductive phase, yields variation, worker transportation and human' labour (Bessou et al., 2012). Some studies not consider the complete life cycle of the product analysed (above all in presence of perennial crops that have a variable life cycle of yields due to different aspects such as changing weather conditions, temporal variation of farm management practices, e.g. fertilizers, irrigation water, pesticides). In addition, many works consider data from one or two productive years (Demircan et al., 2006, Milà i Canals et al., 2006, Kizilaslan, 2009, Bessou et al., 2014), not including nursery and first growing phases characterised by not production. (Vinyes et al., 2018) and they are based on average values (Bravo et al., 2017). The primary and secondary data used for the description of the cultivation were rather vague and not transparent and for agricultural machinery use, irrigation, were not present (Bessou et al. 2012). Moreover, it was not considered the increase and decrease of the yields that could contribute the environmental impacts.

---

<sup>6</sup> The term product includes any good and service. Indeed, ISO 14067:2013 include among the product: service (with tangible and intangible components); software; hardware; processed material; and unprocessed material.

<sup>7</sup> CO<sub>2</sub>equivalent of a specific amount of a greenhouse gas is obtained from the mass of a given greenhouse gas multiplied by its global warming potential (ISO 14067:2013)



The large variations of system boundaries and co-product allocations make it very difficult to compare the studies. The functional unit often used is based on mass of product (e.g. 1 kg, 1 ton etc.), packaging size (e.g. PET clamshell), economic value (e.g. product prize), land use (e.g. 1 ha) and production unit (e.g. animal category) (Schau and Fet, 2008 and Vinyes et al., 2015). The allocation varies with the type of co-product. But not always the co-products are considered. There are ratios on mass, economy or energy values. Furthermore, in some studies, the allocation is not considered or are no clear allocation rules are specified (Bessou et al., 2012).

The present work has been carried out trying to fill the gaps encountered in the various works on the CF and for these reasons the study has considered; the nursery, the first growing (characterised by not production) and the dismantling phase; the entire life cycle of the sweet cherry orchard (20 years), the different yields in production years, the worker transportation, the co-product allocation and the human' labour.

## 2.2 Sweet cherry supply chain: from nursery to processing phases<sup>8</sup>

The study is referred both agricultural and processing phases of sweet cherry (*Prunus avium* L.- “Ferrovia” variety), including PET clamshell production, and destined to fresh market. In particular, the orchard phase regard a conventional cultivation of sweet cherry field located at about 10 km from city of Bisceglie (the district of BAT – Barletta –Andria – Trani) (Figure 14)

The study is referred to a homogenous orchard in the Bisceglie territory (at about 10 km far from the city) in the district of BAT which, as discussed above, is one of the most intensive and important cherry production areas of Apulia (Catalano et al., 2015): this farm utilises conventional production of sweet cherry variety “Ferrovia” as generally performed in this district. Indeed, the cherry production of the farm under study represents almost 60% of the district cherry production, which is equal to 2600 t/y. Additionally the farm represents 1/8 of the surface invested for cherry production in BAT district (800 ha). According to the owner this farm, like so many in this area, do not fully respects the procedural guideline regional for sustainable productions (Catalano et al., 2015). The orchard is composed of a total of 60,000 trees mutually spaced following a 3m 5m layout with a density of 600 trees per ha. Generally, according to the information provided by the farmer, the total production in to 20 years range between 155 and 300 t/ha (corresponding to an average of 228 t/ha), depending upon the climate conditions of the location.

According to the data provided by the farm, orchard’s life-cycle starts with the planting of two-year trees, as previously produced and grown-up in nursery systems, where trees are obtained by grafts scion of sweet cherry into a rootstock such as *Prunus mahaleb* L.. Subsequently cultivation of sweet cherry trees is performed through the following phases, as depicted in Figure 14. The first one lasting three years is characterised by no production and includes the basic farming activities such as tillage, irrigation, organic fertilisation, manual pruning and pest management. For greater understanding and appreciation of the study, the research has implemented a system model that puts together the first growing and the nursery phase into the pre-production phase, because they are both characterised by no production but are clearly essential for development of the next production phase.

---

<sup>8</sup> The description of the sweet cherry supply chain: from nursery to collected centre is part of the section Cherry orchard management of a paper entitled “An input flow analysis for improved environmental sustainability and management of cherry orchards: A case study in the Apulia region”, written by Caterina Tricase, Roberto Rana, Angela M. Andriano and Carlo Ingrao, 2017. Journal of Cleaner Production. 156, 766-774. DOI: 10.1016/j.jclepro.2017.04.088.

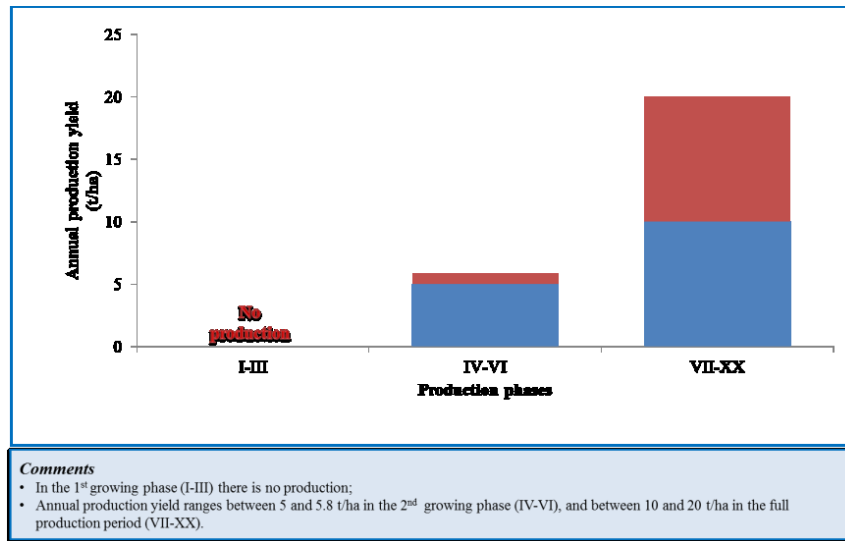

**Figure 12: Cherry orchard life-cycle phases (after three-year tree planting)<sup>9</sup>**

The maximum and minimum cherries yeald are represented by the red and the blue respectively

Over the next three years (IV-VI), production starts with an average yield of 5.4 t/ha: in this phase, in addition to the aforementioned activities, mineral fertilisation is performed through administration on the soil and foliar application. Those two phases constitute the whole growing period within the orchard through which trees reach maturity, and so enter into the full production period (Figure 12). The latter is comprised between the 7<sup>th</sup> and 20<sup>th</sup> year and is characterised by production yields ranging between 10 and 20 t/ha (with an average of 15 t/ha, in agreement with Lugli and Musacchi, 2009) mainly depending upon the soil and climate conditions, as well as the tree dimension and age. It is clarified that in this period the farming activities are the same than those performed in the previous phase, except for the mechanised pruning with the subsequent milling on the soil of the branches. Finally, at the 20<sup>th</sup> year ending, the orchard is dismantled using agricultural machineries and other equipment: the biomass obtained (190 t/ha) is then sent out to treatment.

The harvesting is done in the early morning to reduce the excessive overheating of fruits which are collected by hand using plastic boxes (40 cm x 60 cm). Subsequently sweet cherries are transported by truck to the collection centre, located in the city of Bisceglie, where they are processed in one day for trade using the following treatment: hydrocooling, calibration, selection, packaging, labelling and finally cold storage (Fig. 14).

<sup>9</sup> Tricase, C., Rana, R., Andriano, A. M. and Ingrao, C., 2017. An input flow analysis for improved environmental sustainability and management of cherry orchards: A case study in the Apulia region. *Journal of Cleaner Production*. 156, 766-774. DOI: 10.1016/j.jclepro.2017.04.088.

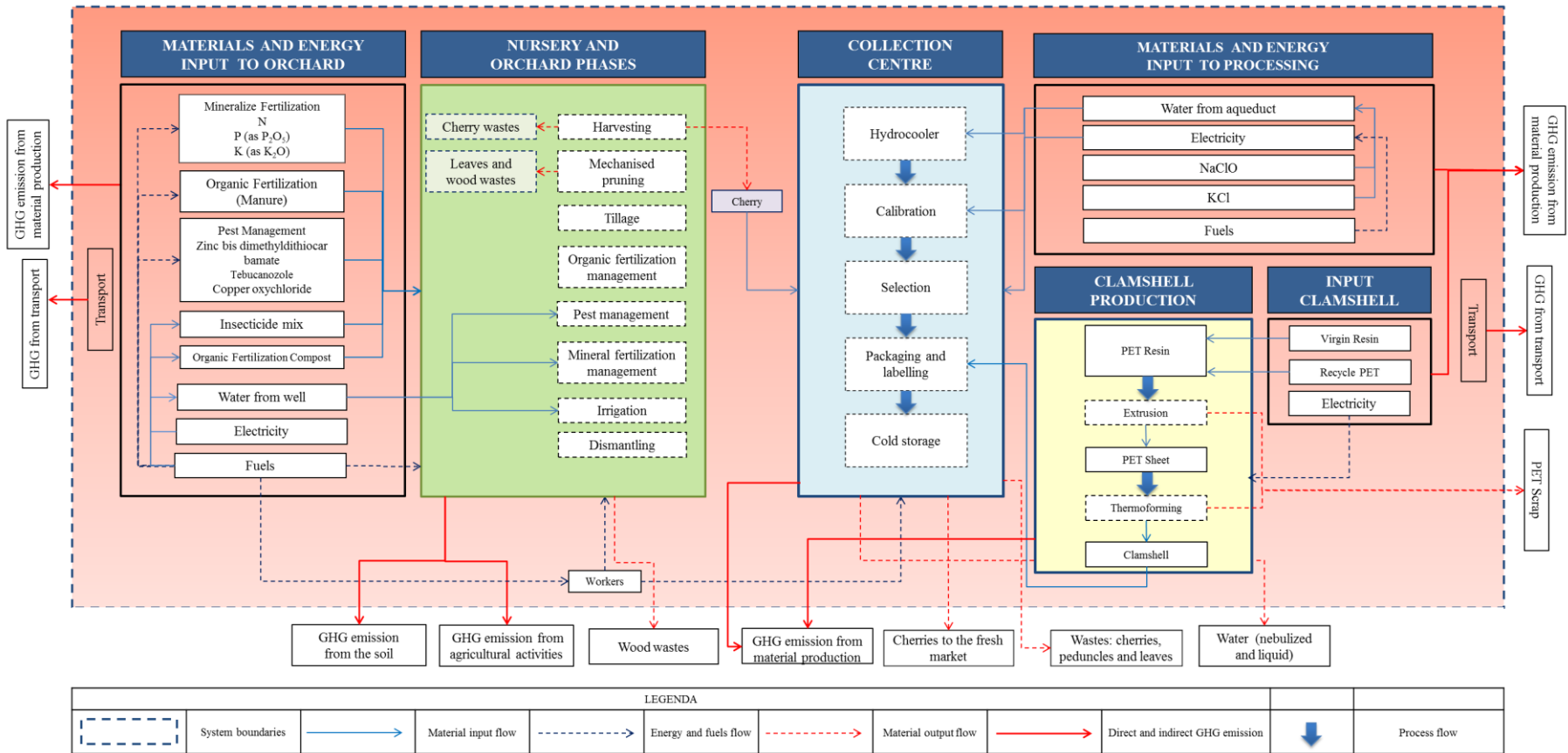

**Figure 13: System boundaries of sweet cherries supply chain investigated**

Since sweet cherry is a very perishable fruit, after the harvesting, it is cool off in order to extending storage duration and shelf life and safeguarding quality of fruit. For this reason, when the sweet cherries arrive to the collection centre are firstly poured out in the hydrocooler which consists in a bed of cold water (0°C) where fruits are cooled and cleaned at the same time. Moreover, to sanitizer and to reduce microbial pathogens water is blend with potassium hypochlorite and potassium chloride. Then by a constant cold-water flow cherry is transferred to the calibration phase where peduncles are cut. At this stage fruits are selected by workers for the fresh market and cherries with damage are eliminated and those not conform to market requests are destined to other uses (e.g. jam production). The selection respect some criteria which concern the dimensions, weight, colour, form and the main qualitative features. Subsequently cherries are packaged using machines that weigh the exact amount for each package and finally it is labelled. All these phases are performed by 20 workers which cover 15 km to reach collected centre by car. Generally, packaging occurred in different size and materials such as PolyVinyl Chloride (PVC), high-density polyethylene (HDPE), PET or cardboard. In the present study cherries are packed in a clamshell made in PET with a capacity of 500 g. Finally, cherries packet is transferred using forklift to the cold storage for maximum two days (at 0.5°C) before sending to the fresh market.

## 2.3 Material and methods<sup>10</sup>

The study according to ISO/TS 14067:2013 implement a CF of sweet cherry production to measure the overall amount of GHG emissions identified in the Kyoto Protocol (i.e. carbon dioxide - CO<sub>2</sub>, methane - CH<sub>4</sub>, nitrous oxide - N<sub>2</sub>O, hydro-fluorocarbons compounds– HFCs, per-fluorocarbons - compounds –PFCs and, sulphur hexafluoride - SF<sub>6</sub>) released directly or indirectly from agriculture and processing phase. The CF is expressed in terms of carbon dioxide equivalent (CO<sub>2eq</sub>) using the correspondent Global Warming Potential (GWP) of each single gas to convert them in CO<sub>2eq</sub> over a fixed period (e.g. 100 years) as shown in table 8 (IPCC, 2007).

---

<sup>10</sup> Tricase, C., Rana, R., Andriano, A. M. and Ingrao, C., 2017. An input flow analysis for improved environmental sustainability and management of cherry orchards: A case study in the Apulia region. *Journal of Cleaner Production*. 156, 766-774. DOI: 10.1016/j.jclepro.2017.04.088.

**Table 7: Kyoto Protocol GHGs and GWP100 values**

GHG	GWP <sub>100</sub> per kg emission (kg CO <sub>2eq</sub> /kg GHG)
Carbon dioxide	1
Methane	25
Nitrous oxide	298
Hydro-fluorocarbons	124-14,800
Per-fluorocarbons	7390-12,200
Sulphurhexafluoride	22,800

Source: IPCC, 2007.

Furthermore, because the orchard surface was already used to produce sweet cherry the calculation of Direct Land Use Change (DLUC) was not taken into consideration in the present study.

According to the ISO/TS 14067:2013 this work is based upon a LCA approach that consider the following phases, as established by the ISO 14040:2006: (1) Goal and scope definition; (2) Life Cycle Inventory (LCI) analysis; (3) Life Cycle Impact Assessment (LCIA); (4) Life Cycle Interpretation. In this context, the present assessment was developed with the goal to quantifying the GWP<sub>100</sub> related to a sweet cherry production from the field to industry process in South Italy via application of PCF methodology. In this way, it was possible to stress the GHGs being more responsible for the GWP<sub>100</sub> value and the sweet cherry supply chain phases that contribute most to the emission of those gases. It is believed that this aspect is of fundamental importance to identify technical solutions oriented to GWP<sub>100</sub> reduction.

The aforementioned research was divided into the following two studies: the first was focussed upon work-setting and, so, included the in-depth analysis of the system investigated, the definition of the objectives, as well as of the Functional Unit (FU) and the system boundaries, and both collection and analysis of the input inventories. Whilst, the second is about full life-cycle inventory and impact assessment, including both interpretation and improvement

In this context, this study reports upon the most significant input materials, processes and phases falling within the life-cycle management of the system boundaries considered.

The present study has been performed because the literature review has shown deficiencies in PCF assessments; therefore, this research could contribute to enrich the international knowledge on the environmental burdens associated with sweet cherry production. In addition, this work can represent a case study of best practices for agriculture sector according to agricultural European rules (i.e. Common Agricultural Policy – CAP 2014-2020) that promote innovation/internationalization of enterprise through operational funds (Andriano et al., 2015). In addition to this, environmental sustainability actions are desirable to meet more the consumers' food demands, and so to win new

market shares. Indeed, consumers also, in the last twenty years, have increased awareness of the importance of healthy nutrition and the environmental impact deriving from fruit production. (Burt, 2004; Johnston et al., 2014). To support those actions, and so to promote sweet cherry production, it is needed to develop environmental assessment that provide useful information deriving from data inventoried, methodologies applied and results gathered in the food sector (European Commission, 2015). In this context, the Apulia region has developed and approved the Rural Development Programme (RDP) (Italy - Rural Development Programme (Regional) – Puglia, 2015) that contains the environmental protection objectives in the agro-food sector, according to the aforementioned rules proposed by the European Union, for underpin the local agricultural economy.

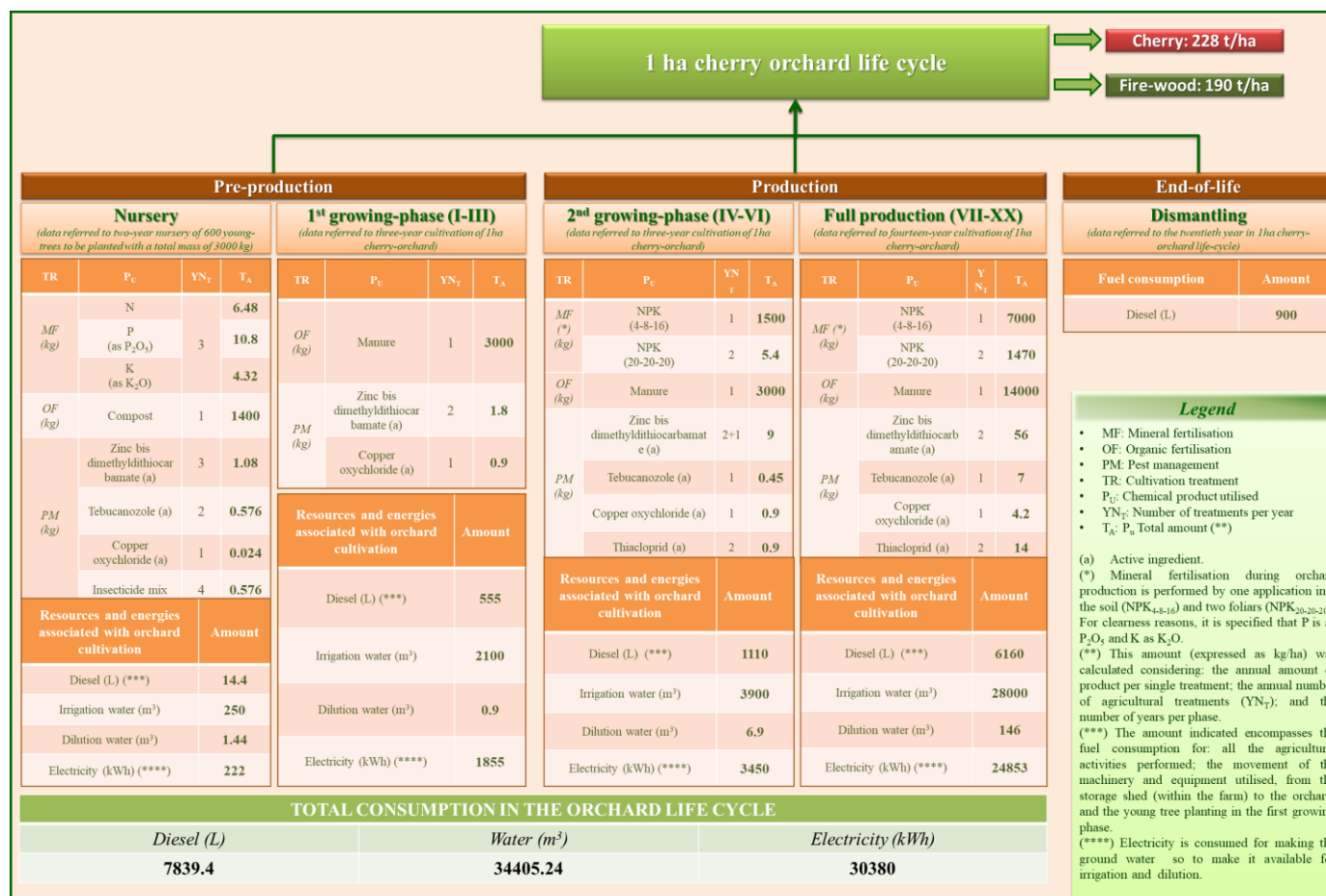

**Figure 14: Boundaries of cherry orchard system investigated<sup>11</sup>**

<sup>11</sup> Tricase, C., Rana, R., Andriano, A. M. and Ingraio, C., 2017. An input flow analysis for improved environmental sustainability and management of cherry orchards: A case study in the Apulia region. Journal of Cleaner Production. 156, 766-774. DOI: 10.1016/j.jclepro.2017.04.088.



### 2.3.1 Goal and scope

The thesis aims to assess the GHGs emission of sweet cherry (*Prunus avium L.*) production from nursery to the collected centre (where cherries are processed for the fresh market) of a firm located in the BAT district situated in Apulia region according to ISO/TS 14067:2013 methodology based on Life Cycle Assessment (LCA).

The research was aimed at collecting site specific data for the analysis and interpretation of the material and energy inputs related to the life-cycle of a cherry orchard and to the processing phase in a collected centre in the Apulia region. The study was, indeed, designed to create an invaluable building block usable for:

- development of the life-cycle inventory phase, by providing an exhaustive and extensive description of the aforementioned inputs;
- assessment of the output resources and emissions as well as of the related environmental impacts; and
- improvement of the orchard management system and environmental sustainability.

Moreover, the study is the first step of an in-depth investigation course in the cherry sector because it represents an important market share and economic revenue for the Region, and so significantly sustains its economy.

Furthermore, as already mentioned, policies and strategies are currently issued to support the development and promotion of more environmentally sustainable agricultures. In particular, lifecycle environmental assessments are increasingly being required to find solutions and strategies for more efficient, responsible and sustainable manners of orchard farming and management systems. From this point-of-view, this study and, overall, the whole research which it is part of could make an important contribution in the cherry sector.

One more reason for the study development is that, as concluded previously, just a few studies have been conducted in the cherry sector in recent years, and none of them considered the entire lifecycle performing inventory analyses like the one discussed in this paper. Therefore, according to this research' team, the study may be considered as a stand-alone one that, based upon its structure, methodological approach and findings, may contribute to enriching the international scientific literature and knowledge in the field.

The study targets farmers, agronomists, LCA practitioners, company managers and several decision makers to inform them about the material and energy input-flows to be taken into account when intending both to develop eLCAs, and plan strategies for improved management in the cherry sector

at the regional and global scale. Following the LCA framework, both the FU and the system boundaries were defined. In agreement with what done by several author-teams (also in the field of other tree crops) like, for instance, Cerutti et al. (2011, 2013, 2015), and Ingrao et al. (2015), the FU was represented by 1ha cultivated orchard considering a 20-year lifetime, whilst the system boundaries included: 1). the nursery phase; 2) two growing phases (I-III from planting, and IV-VI); 3) the full production period (VII-XX); 4) the end of life of the orchard (at the end of the 20th year). In particular, it is specified that the nursery and the first orchard life-cycle phase were grouped into the 'Orchard pre-production phase'. This was done by the study because both phases are without cherry production and, so, grouping them into one single phase would have facilitated the modelling of the system and the analysis of the data inventoried.

For greater understanding, the system boundaries of cherry orchard were depicted in Fig. 5 where there is evidence that all the upstream processes following within the four core-phases above, namely the agricultural activities and treatments as well as the production of the materials and fuels involved, were taken into account.

Finally, it is underscored that the study was focalised just upon the orchard life-cycle because the agricultural phase is acknowledged worldwide as the most impacting phase in the whole food supply chain, as documented in several papers like that of Cerutti et al. (2011).

### **2.3.2 Functional Unit and system boundary**

The Functional Unit (FU) is equal to 0.5 kg of sweet cherries packed in clamshell made in PET weighing 19 g and the system boundary is represented by the phases from the nursery to fruit processing including the clamshell production (Figure 13). To ensure a correct damage allocation (the damage allocation partitions the inputs and outputs of the system boundaries analysed considering the different FUs – ISO 14067:2013) it was considered the mass value of conform and not fresh cherry equal to 77,76% and 22,24% respectively.

In order to develop a more comprehensive study, the work apart of identify the principal FU, they have also considered the FUs of the main processes of sweet cherry supply chain, as: 1 hectare of cherry orchard life cycle and 1 kg of PET clamshell production (Table 9). Moreover, according to ISO 14044:2006 it was being necessary considered the damage allocation for each main phase of the cherry production.

In particular in the orchard phase it has been considered the allocation based on the economic value of fresh cherries and woods and equal to 95.05% and 4.95% respectively; whereas, for processing

phase it has based on mass criteria and is equal to 77.76% for cherry destined to the sale and 22,24% for cherry with a second calibre; for PET clamshell production it has based, like before, on mass criteria and equal to 95.36% for clamshell and 4.65% for PET scrap. According to Ingrao et al. (2014), PET thanks its mechanic and good barrier proprieties is used to packaging fresh fruit. Moreover, currently it is produced across plastic waste-recovery processes obtaining recycled PET.

**Table 8: Functional units considered for the CF of sweet cherry**

Process	Functional Unit (FU)	Unit of Measure (UM)
Nursery Phase	1	P
Orchard management Phase	1	ha
Cherry processed	1	kg
PET Clamshell	1	kg
Cherry in PET clamshell	0.5	kg

### 2.3.3 Life cycle inventory analysis

The following section presents the methodology used to evaluated the GHG emission from the agricultural activity (such as pruning, tillage, etc.), according to Tricase et al. (2017) and the subsequent phases characterized by hydrocooling, calibration, selection, packaging, labelling and finally storage in refrigerating room.

The study started with an in-depth investigation of the cherry growing system to enable a better collection and analysis of the input inventories needed for further assessments. In this regard, the inventory phase was specifically developed to quantify the usage of resources and materials and the consumption of energy (electricity and diesel), as well as the transports involved. As it comes to a specialised system being highly interconnected with the local territories, in line with the studies reviewed (Demircan et al., 2006; Kizilaslan, 2009; Litskas et al., 2011; and Cappelletti et al., 2015), priority was given to the use of site-specific data (primary data), mainly represented by the types and amounts of material and energy inputs that were provided by local farmers. Additionally, following the standard practice in LCA, secondary data were extrapolated from the Ecoinvent database that, as is known, is available in SimaPro (2006).

This was done because, as also highlighted in several papers dealing with LCA such as, for instance, Ingrao et al. (2015), Ecoivent can be considered as a reliable background-data source and, indeed, as stated by Frischknecht and Rebitzerb (2005), accommodates the majority of the background materials and processes that are often required in LCAs.

In particular, for the study development the it is accessed the Ecoinvent modules of:

- extraction of natural resources, as well as the production of materials (i.e. fertilisers and pesticides), energies and fuels;
- agricultural activities like tillage, seeding, irrigation, administration of plant protection and fertilising chemicals, manure spreading and so;
- transports of both materials and workers.

For data collection, several procedures and tools were followed: for instance, interviews with the orchard owner during cherry cultivation site investigations and with the manager of cherry collected centre. Moreover, were made check-lists were used for recording data and information. This phase was performed through in-depth meetings also with farmers and agronomists to assure common understanding of the questions asked and so optimise data collection and analysis. For greater understanding, it is clarified that the material and energy input flows associated with the orchard system can be found depicted in Figure 14. The values indicated were calculated based upon the agricultural activities and treatments performed during the time-spans associated with the phases considered (Table 9 – 10 – 11 – 12 - 13 and 14).

**Table 9: Input inventory-data related to Nursery phase**

Functional Unit (FU)	600	plants	Data referred to two years of 600 young-trees to planted
<b>Input flow Nursery Phase</b>	<b>Physic amount</b>	<b>Measure unit</b>	<b>Comment</b>
<i>Resources</i>			
Occupation, permanent crop, fruit, intensive	0.048	ha	This value was considered according to the Ecoinvent model
Water, groundwater consumption	251.44	ton	Primary data provided by farmer referred for the irrigation and fertigation activities
<i>Raw materials and fossil fuels</i>			
Compost, at plant	1400	kg	Primary data provided by farmer according to the Ecoinvent model
Fertiliser (N)	6.48	kg	Primary data provided by farmer according to the Ecoinvent model
Fertiliser (P <sub>2</sub> O <sub>5</sub> )	10.8	kg	Primary data provided by farmer according to the Ecoinvent model
Fertiliser (K <sub>2</sub> O)	4.32	kg	Primary data provided by farmer according to the Ecoinvent model
Insecticides, at regional storehouse	0.576	kg	Primary data provided by farmer according to the Ecoinvent model
Fungicides, at regional storehouse	1.68	kg	Primary data provided by farmer according to the Ecoinvent model
<i>Transport</i>			
Transport, lorry 3.5-7.5t, EURO4	56	tkm	Compost road transport
Transport, lorry 3.5-7.5t, EURO4	28.58	tkm	Fertiliser NPK road transport
Transport, lorry 3.5-7.5t, EURO4	4.12	tkm	Fungicides and insecticides road transport
Transport, passenger car, diesel, EURO5, city car	0.0553	personkm	Workers transport
<i>Electricity</i>			
Electricity, low voltage, production IT, at grid/IT S	222	kWh	This value comes from the utilisation of the groundwater pumping station for the irrigation and fertigation activities, with a consumption factor of 0.883 kWh per m <sup>3</sup> of water extracted

**Table 10: Input inventory-data related to I phase (I-III)**

Functional Unit (FU)	1	ha	Data referred to tree-year cultivation of 1 ha cherry orchard
<b>Input flow I Phase</b>	<b>Physic amount</b>	<b>Measure unit</b>	<b>Comment</b>
<i>Resources</i>			
Water, groundwater consumption	2100.9	ton	Primary data provided by farmer referred for the irrigation and fertigation activities
<i>Raw materials and fossil fuels</i>			
Fungicides	2.7	kg	Primary data provided by farmer
Manure Spreading	75000	kg	Primary data provided by farmer
<i>Agricultural treatments</i>			
Pest Management	3	ha	These phases were implemented using models already contained in Ecoinvent. Additionally, in each of those modules the inventory takes into account the diesel fuel consumption and the amount of agricultural machinery and of the shed, which has to be attributed to the single agricultural activity. Also taken into consideration is the amount of emissions to the air from diesel combustion and the emission to the soil from tyre abrasion during the work process. However, in these models' adjustments were needed. In particular, the diesel consumption values and the values of the emissions (including those of GHGs) resulting from combustion of those diesel amounts were modified inputting those provided by the farmer. This was done by proportioning the emission values already present within those models to the diesel consumption values specifically provided by the farmer. It should be observed that corrections have not been made upon the emissions to the soil from tyre abrasion. This is because as those conditions are unknown. Also, data and information about the eventual differences of machineries considered compared to those used in the system under study are not available for related changes.
Ploughing	3	ha	
<i>Transport</i>			
Transport, lorry 3.5-7.5t, EURO 4	4	tkm	Fertiliser and fungicides road transport
Transport, lorry 7.5-16t, EURO 4	6000	tkm	Manure road transport
Transport, passenger car, diesel, EURO 5, city car	360	personkm	Workers transport
<i>Electricity</i>			
Electricity, low voltage, production IT	1855	kWh	This value comes from the utilisation of the groundwater pumping station for the irrigation and fertigation activities, with a consumption factor of 0.883 kWh per m <sup>3</sup> of water extracted
<i>Emissions to air</i>			
Dinitrogen monoxide	10.58	kg	Value referred to FU
Methane	348.76	kg	Value referred to FU

Sustainability and innovation of the sweet cherry supply chain

Functional Unit (FU)	1	ha	Data referred to tree-year cultivation of 1 ha cherry orchard
<b>Input flow I Phase</b>	<b>Physic amount</b>	<b>Measure unit</b>	<b>Comment</b>
Carbon dioxide	12299	kg	Value referred to FU

**Table 11: Input inventory-data related to II phase (IV-VI)**

Functional Unit (FU)	1	ha	Data referred to tree-year cultivation of 1 ha cherry orchard
<b>Input flow II Phase</b>	<b>Physic amount</b>	<b>Measure unit</b>	<b>Comment</b>
<i>Resources</i>			
Water, groundwater consumption	3906.9	ton	Primary data provided by farmer referred for the irrigation and fertigation activities
<i>Raw materials and fossil fuels</i>			
Fertiliser (K <sub>2</sub> O)	0.2508	ton	Primary data provided by farmer according to the Ecoinvent model
Fertiliser (P <sub>2</sub> O <sub>5</sub> )	0.1218	ton	Primary data provided by farmer according to the Ecoinvent model
Fertiliser (N)	0.0618	ton	Primary data provided by farmer according to the Ecoinvent model
Insecticides	0.9	kg	Value referred to the Thiacloprid administration
Fungicides	10.35	kg	Value referred to the Zinc bis dimethyldithiocarbamate (9kg), Copper oxychloride (0.9 kg) and Tebucanazole (0,45kg) administration
Manure Spreading	75000	kg	Primary data provided by farmer
<i>Agricultural treatments</i>			

Pest Management

3

ha

These phases were implemented using models already contained in Ecoinvent. Additionally, in each of those modules the inventory takes into account the diesel fuel consumption and the amount of agricultural machinery and of the shed, which has to be attributed to the single agricultural activity. Also taken into consideration is the amount of emissions to the air from diesel combustion and the emission to the soil from tyre abrasion during the work process. However, in these models' adjustments were needed. In particular, the diesel consumption values and the values of the emissions (including those of GHGs) resulting from combustion of those diesel amounts were modified inputting those provided by the farmer. This was done by proportioning the emission

## Sustainability and innovation of the sweet cherry supply chain

Functional Unit (FU)	1	ha	Data referred to tree-year cultivation of 1 ha cherry orchard
<b>Input flow II Phase</b>	<b>Physic amount</b>	<b>Measure unit</b>	<b>Comment</b>
Ploughing	3	ha	values already present within those models to the diesel consumption values specifically provided by the farmer. It should be observed that corrections have not been made upon the emissions to the soil from tyre abrasion. This is because as those conditions are unknown. Also, data and information about the eventual differences of machineries considered compared to those used in the system under study are not available for related changes.
Fertilizer Administration	3	ha	
<i>Transport</i>			
Transport, lorry 3.5-7.5t, EURO 4	19.04	tkm	Fertiliser, insecticides and fungicides road transport
Transport, lorry 7.5-16t, EURO 4	6000	tkm	Manure road transport
Transport, lorry 3.5-7.5t, EURO 4	1329.27	tkm	Fertiliser NPK road transport
Transport, passenger car, diesel, EURO 5, city car	1530	personkm	Workers transport
<i>Electricity</i>			
Electricity, low voltage	3450	kWh	This value comes from the utilisation of the groundwater pumping station for the irrigation and fertigation activities, with a consumption factor of 0.883 kWh per m <sup>3</sup> of water extracted
<i>Emissions to air</i>			
Dinitrogen monoxide	10.58	kg	Value referred to FU
Methane	348.76	kg	Value referred to FU
Carbon dioxide	10732.59	kg	Value referred to FU



**Table 12: Input inventory-data related to Full Production phase (VII-XX)**

Functional Unit (FU)	1	ha	Data referred to tree-year cultivation of 1 ha cherry orchard
<b>Input flow Full Production phase</b>	<b>Physic amount</b>	<b>Measure unit</b>	<b>Comment</b>
<i>Resources</i>			
Water, groundwater consumption	28146	ton	Primary data provided by farmer referred for the irrigation and fertigation activities
<i>Raw materials and fossil fuels</i>			
Fertiliser (N)	0.574	ton	Primary data provided by farmer according to the Ecoinvent model
Fertiliser (P <sub>2</sub> O <sub>5</sub> )	0.854	ton	Primary data provided by farmer according to the Ecoinvent model
Fertiliser (K <sub>2</sub> O)	1.414	ton	Primary data provided by farmer according to the Ecoinvent model
Insecticides	14	kg	Value referred to the Thiacloprid administration
Fungicides	67.2	kg	Value referred to the Zinc bis dimethyldithiocarbamate (56kg), Copper oxychloride (4.2 kg) and Tebucanozole (7kg) administration
Manure Spreading	350000	kg	Primary data provided by farmer
<i>Agricultural treatments</i>			
Pest Management	14	ha	These phases were implemented using models already contained in Ecoinvent. Additionally, in each of those modules the inventory takes into account the diesel fuel consumption and the amount of agricultural machinery and of the shed, which has to be attributed to the single agricultural activity. Also taken into consideration is the amount of emissions to the air from diesel combustion and the emission to the soil from tyre abrasion during the work process. However, in these models' adjustments were needed. In particular, the diesel consumption values and the values of the emissions (including those of GHGs) resulting from combustion of those diesel amounts were modified inputting those provided by the farmer. This was done by proportioning the emission values already present within those models to the diesel consumption values specifically provided by the farmer. It should be observed that corrections have not been made upon the emissions to the soil from tyre abrasion. This is because as those conditions are unknown. Also, data and information about the eventual differences of machineries considered compared to those used in the system under study are not available for related changes.
Ploughing	14	ha	
Fertilizer Administration	14	ha	
Chainsawing, hand felling and delimiting	7	hr	Primary data provided by farmer
Wood chopping, mobile chopper	67780	kg	Primary data provided by farmer

Sustainability and innovation of the sweet cherry supply chain

Functional Unit (FU)	1	ha	Data referred to tree-year cultivation of 1 ha cherry orchard
<b>Input flow Full Production phase</b>	<b>Physic amount</b>	<b>Measure unit</b>	<b>Comment</b>
<i>Transport</i>			
Transport, lorry 3.5-7.5t, EURO 4	139.56	tkm	Fertiliser, insecticides and fungicides road transport
Transport, lorry 7.5-16t, EURO 4	28000	tkm	Manure road transport
Transport, lorry 3.5-7.5t, EURO 4	7479.01	tkm	Fertiliser NPK road transport
Transport, passenger car, diesel, EURO 5, city car	9240	personkm	Workers transport
<i>Electricity</i>			
Electricity, low voltage	24853	kWh	This value comes from the utilisation of the groundwater pumping station for the irrigation and fertigation activities, with a consumption factor of 0.883kWh per m <sup>3</sup> of water extracted
<i>Emissions to air</i>			
<i>Dinitrogen monoxide</i>	49.35	kg	Value referred to FU
<i>Methane</i>	1627.57	kg	Value referred to FU
Carbon dioxide	-12660.37	kg	Value referred to FU

**Table 13: Input inventory-data related to Clamshell PET production**

Functional Unit (FU)	1,049	kg	Value obtained by the allocation between PET clamshell and scrap
<b>Input flow Clamshell PET production</b>	<b>Physic amount</b>	<b>Measure unit</b>	<b>Comment</b>
<i>Raw materials and fossil fuels</i>			
Polyethylene terephthalate, granulate, amorphous, at plant	0.862	kg	Primary data provided by company according to the Ecoinvent model
Recycled postconsumer PET pellet	0.187	kg	Primary data provided by company according to the Ecoinvent model
<i>Transport</i>			
Transport, transoceanic freight ship	662,447	tkm	Maritime transport from Brazil to Rotterdam
Transport, lorry >32t, EURO 4	138,179	tkm	Road transport from Rotterdam to Rutigliano
Transport, lorry >32t, EURO 4	0.06	tkm	Road transport from Rutigliano to Bisceglie
<i>Electricity</i>			
Thermoforming, with calendering	1,023	kg	Global energy consumption for extrusion and thermoforming (with calendering).
Extrusion, plastic film	1,049	kg	

**Table 14: Input inventory-data related to Processed Cherry**

Functional Unit (FU)	1.43	ton	Value obtained by the allocation between cherry destined to the sale and cherry of second calibre
<b>Input flow Processed Cherry</b>	<b>Physic amount</b>	<b>Measure unit</b>	<b>Comment</b>
<i>Raw materials and fossil fuels</i>			
Cherry agriculture management	0.00626	ha	Value obtained by the allocation between cherry destined to the sale and cherry of second calibre
<i>Transport</i>			
Transport, passenger car, diesel, EURO5	0.47	personkm	Workers transport
Transport, lorry 3.5-7.5t, EURO4/RER U	42.9	tkm	Road transport from cherry orchard to collected centre
Diesel, at regional storage/RER S	0.125	kg	This value was considered according to the Ecoinvent model
<i>Electricity</i>			
Electricity, low voltage, production IT	116.21	kWh	Electricity to processing cherries. Primary data provided by collected centre
<i>Waste to treatment</i>			
Disposal, municipal solid waste, 22.9% water, to sanitary landfill	0.143	ton	Scrap by cherries processed. Primary data provided by collected centre

### 2.3.4 Methane and nitrous oxide from manure management

As already mentioned manure is administered on the soil during the orchard management to improve soil structure and to enrich it of organic substance, to decrease the chemical fertilizer use and to increase the soil fertility (Najm et al., 2012). However, since manure contains some inorganic element such as N, C and water it is an essential substrate for microbial production of  $N_2O$  and  $CH_4$ . These GHGs can be emitted at each stage of manure or slurry management specially when they are storage for “maturation” and subsequently spread to land. As regards  $CH_4$  derives both from manure management and enteric fermentation of ruminant animals (e.g. cattle). Farmers activities influence the magnitude of this emission. For instance,  $CH_4$  losses depends on the time manure is stored and typology of storage (inside of barn or outdoor in covered or open manure pit), external temperature and manure composition. The release of this gas depends principally on feed intake, size, growth rate and age of the animal. In fact, methane is a by-product of ruminant digestive process (enteric fermentation) where carbohydrates are degraded by micro-organisms into simple molecules to be absorption into the bloodstream. The ruminant livestock (such as cattle) produces major methane compared to non-ruminant livestock (e.g., pigs) thanks their digestive process that fosters enteric fermentation of their diet.

To calculate methane emissions from enteric fermentation and manure before the administration on the soil of sweet cherry orchard, the study has considered IPCC (2007) method and the primary data was collected by the farmer whereas those not available was obtained from ISPRA (2016). This report, in fact, contains many data characteristic of Italian livestock GHG emissions. Furthermore, because in literature there is no consensus of the meaning of “manure”, according to IPCC (2007), in the present study this term comprises both dung and urine (solid and slurry substances) produced by cattle.

Firstly, methane emissions produced from enteric fermentation for livestock category for was calculated using equation 10.19, proposed *Tier 2* by IPCC (2007) considering the following parameters:

- $N_{(ent\_fe)}$  = (the number of head of livestock) 0.71. This parameter has been calculated considering the average weight of a dairy cattle (600 kg), the average annual amount of manure produced by a head (35 t year) in Italy and the annual amount distributed on the soil of sweet cherry orchard (25 t) (CRPA, 2012).

- $EF_{(ent\_fe)}$  = (emission factor calculated considering the value propose by ISPRA),  $138.7 \text{ kg CH}_4 \text{ head}^{-1} \text{ yr}^{-1}$ .

Therefore, the  $\text{CH}_4$  emission from enteric fermentation of this work is equal to  $99.07 \text{ kgCH}_4 \text{ head}^{-1} \text{ yr}^{-1}$ .

Secondly methane released from manure management was assessed according to IPCC (2007) *Tier 2* approach using equation 10.22 considering the following parameters:

- $N_{(mm)}$  = (number of head of livestock) 0.71
- $EF_{(mm)}$  = (emission factor for the defined livestock population in Italy)  $15.04 \text{ kg CH}_4 \text{ head}^{-1} \text{ yr}^{-1}$  (ISPRA, 2016)

Since manure is composed mainly by organic material, before it is applied to land, during “maturation phase” it can produce nitrous oxide directly and indirectly. This gas is losses from the soil (after manures administration) thank to aerobic/anaerobic processes such as nitrification/denitrification that modified  $\text{NH}_4^+$  directly in  $\text{NO}_2$  or to  $\text{NO}_3^-$  and subsequently in  $\text{NO}_2$  (Chadwick et al., 2001). However, since this process required a period of time often there is a delay between manure application and  $\text{N}_2\text{O}$  emissions (Rochette et al., 2008.) (Fangueiro et al., 2010).

Therefore, assessment of direct  $\text{N}_2\text{O}$  ( $\text{N}_2\text{ODirect-N}$ ) emissions from manure was estimated according to equations 10.25 (*Tier 1*) of the ‘IPCC methodology (2007) considering the following parameters:

- $N_{(dir)}$  = (number of head of livestock) 0.71
- $Nex_{(dir)}$  = (annual average N excretion per head of species)  $116 \text{ kg N head}^{-1} \text{ yr}^{-1}$  (ISPRA 2016).
- $MS_{(dir)}$  = (fraction of total annual nitrogen excretion from storage manure management system) 60%
- $EF_{(dir)}$  = (emission factor for direct  $\text{N}_2\text{O}$  emissions country specific)  $0.005 \text{ kg N}_2\text{O-N/kg N}$  (ISPRA 2016)

As regard the indirect emissions of  $\text{N}_2\text{O}$  they take place through two indirect pathways:

1) volatilisation of nitrogen as  $\text{NH}_3$  and  $\text{NO}_x$  emitted not only from agricultural activities (i.e. fertilisers and manures administration) but also fossil fuel combustion, etc. These gases thanks to

the chemical reduction reactions that occur in the atmosphere they can be fall down as  $\text{NH}_4^+$  and  $\text{NO}_3^-$  on the soils and/or the surface of lakes and/or other waters body;

2) leaching and runoff from land of N from synthetic and organic fertiliser additions, crop residues, etc. (IPPC 2007).

The estimate indirect  $\text{N}_2\text{O}$  emissions due to nitrogen losses from manure management is calculated based on IPCC (2007) Guidelines, *Tier 2*, equation 10.26 and 10.27. In particular the former equation considers following parameters:

- $N_{(\text{ind})}$ : (number of head of livestock) 0.71
- $N_{\text{ex}(\text{ind})}$ = (annual average N excretion per head of species)  $116 \text{ kg N head}^{-1} \text{ yr}^{-1}$  (ISPRA, 2016)
- $MS_{(\text{ind})}$ = (fraction of total annual nitrogen excretion from storage manure management system) 60%
- $\text{Frac}_{\text{Gas\_ind}}(\%)$  = (percent of managed manure nitrogen for dairy cattle that volatilizes as  $\text{NH}_3$  and  $\text{NO}_x$  in the storage manure management system), 21.83% (ISPRA 2016).

The latter equation contemplates following parameters:

- $N_{\text{volatilization-ind}}$ = amount of manure nitrogen that is lost due to volatilisation of  $\text{NH}_3$  and  $\text{NO}_x$ ,  $\text{kg N yr}^{-1}$  equal to  $0.18 \text{ kg N yr}^{-1}$
- $EF_{\text{ind}}$ = emission factor for  $\text{N}_2\text{O}$  emissions from atmospheric deposition of nitrogen on soils and water surfaces,  $.01 \text{ kg N}_2\text{O-N (kg NH}_3\text{-N + NO}_x\text{-N volatilised)}^{-1}$  (IPCC, 2007).

Finally leaching and runoff of nitrogen from manure management were not considered since manure was stored in a close structure that not allowed losses of elements.

### **2.3.5 Nitrous oxide and carbon dioxide from soil management**

In the CF assessment it is fundamental calculate the direct and indirect emissions of  $\text{CO}_2$ ,  $\text{CH}_4$  and  $\text{N}_2\text{O}$  coming from the soil management. However,  $\text{CH}_4$  is mainly produced in rise cultivation through methanogenesis and generally it losses immediately after manure administration to land. Usually its release decrease in few days since methanogenesis is a sensitive process depending on oxygen concentration and diffusion into the manure that inhibits methane production (Chadwick et

al., 2011). For this reason, it is considered in the present study CH<sub>4</sub> emissions from manure administration negligible.

According to Ingrao et al. (2015) the NO<sub>2</sub> release depends on the microbial activities (nitrification and denitrification) and the amount of nitrogen compound (i.e. ammonia, nitrates, nitrites, etc.) present in the soil. This quantity can be varying based on the soil characteristics and agriculture management such as chemical or organic fertilization contributing to NO<sub>2</sub> released. In the present work the assessment of direct and indirect NO<sub>2</sub> (N<sub>2</sub>O<sub>Direct</sub> and N<sub>2</sub>O<sub>Indirect</sub>) emissions was calculated using the equations 11.1 and 11.9 of IPCC methods (2006) respectively. Therefore, for the orchard analysed N<sub>2</sub>O direct emissions principally coming from the administration of mineral, organic fertilization and crop residues (leaves and wood waste). For this reason, the aforementioned equation N<sub>2</sub>O<sub>Direct</sub> is equal to:

$$N_2O = N_{Ninputs} \times 44/28$$

N<sub>2</sub>O–N<sub>Ninputs</sub>, was calculated considering the following parameters:

- F<sub>SN</sub> (total amount of synthetic fertiliser N applied to soil during all orchard life): 346.48 kg/ha of N;
- F<sub>ON</sub> was calculated considering value of manure and compost obtained from laboratory analyses (table 15). The total amount of organic N applied to soil during all orchard life is equal to kg/ha of N 3419.6 kg/ha.

**Table 15: Concentration of nitrogen in organic fertilizers**

Typology of fertiliser	Concentration (% of weight fertiliser)
Manure	0.68
Compost	1.4

Source: personal elaboration

F<sub>CR</sub> was equal to 1.94 t/ha for all life cycle orchard. In particular, this value was obtained considering data provide by farmer:

- a) the amount of wood and leaves collected during pruning activity in pre-production and 2<sup>nd</sup> growing phase (8 year) equal to 0.33 t/ha (dry weight - dwt) and 0.80 t/ha (dwt) per year respectively;
- b) the amount of wood and leaves collected during pruning activity in production phase (14 year) equal to 4.76 t/h and 3.28 t/h per year respectively;

and data founded in literature:

- a) the average concentration of nitrogen in leaves equal to 2.35% of dry matter (Fallahi et al., 1993) and in wood equal to 1.02 % of dry matter (Bilandzija et al., 2012).
- $EF_1$  the emission factor was chosen the default value equal to 0.01.

Regarding the indirect  $NO_2$  emission the value obtained from the equation 11.9, *Tier 1*, of IPCC (2007) was equal to  $N_2O_{(indirect)}$  20.69 kg/ha of  $NO_2$ .

During the last century, carbon (C) loss from cultivated soils has in part contributed to the increasing trend for global warming (IPCC, 2007). In particular, the  $CO_2$  balance depend principally on agricultural activity and specially from: 1) fossil fuel consumption for cultivation managements (i.e. tillage, mineral and organic fertiliser administration etc.), material production and workers/material transportation; 2) electricity consumption for irrigation and dilution water; 3) SOC oxidation due to agricultural practices (i.e. tillage); 4) C sequestration from wood waste derived from pruning activity. According to Tricase et al. (2017) the total amount of diesel and electricity consumption are equal to 9349.63 L and 30380 kWh whereas the correspondent emission factors extrapolated by Guidance for Voluntary Corporate Greenhouse Gas Reporting (Ministry for the Environment, 2016) and ISPRA, (2015) are 2.72 kg  $CO_{2eq}/L$  and 0.3268 kg  $CO_{2eq}/kWh$  respectively.

In the last fifty – sixty years the intensive agricultural activity (e.g. tillage, mineral fertilisers, removal of pruning residues, etc.) have contributed to oxidation of SOC (Soil Organic Carbon) (e.g. about 1% in Mediterranean soil) and consequently to increase  $CO_2$  emission in the atmosphere (Xiloyannis et al., 2015). Specially in conventional orchard the SOC reduction is generated principally by tillage and burning of pruning residues. In the present work tillage is the only negative one that cause the  $CO_2$  release since the pruning residues are not burned but milled and leaved in the soil enhancing the SOC amount. To valuated this phenomenon, it is important to estimate the Carbon balance (Cb) although few works on orchards are performed to date and none of them on sweet cherry production.

According to Zanotelli et al. (2015) the Cb is obtained considering the Net Ecosystem Balance (NEBC) based on the equation:

$$NEBC=NEP+LTC \tag{1}$$



where

NEP is the net ecosystem production,  $\text{kg C ha}^{-1}\text{yr}^{-1}$ . It is calculated considering the difference between all (above and below-ground) the net primary production (NPP) and the heterotrophic component of soil respiration (Rh). The latter consider also the anthropogenic activity such as tillage.

LTC is lateral transport of carbon ( $\text{kg C ha}^{-1}\text{yr}^{-1}$ ), which considered the anthropogenic imports such as organic fertilizer (OF) administration and exports i.e. fruit harvested (FH) (Montanaro et al., 2017 and Zanotelli et al., 2013). Specially in the present study pruning is considered as importance because, as above mentioned, shoots are milling with the soil.

In table 16 is presented the calculation of NECB where some data are obtaining from farmer (such as fruit harvested and waste, pruning and leaves production, woods and roots, organic fertilizer) and some others from literature (such as woods and roots yearly increment, moisture and carbon content in woods and fruits, weeds production and heterotrophic soil respiration, Rh) (Zanotelli et al., 2013; Montanaro et al., 2017). The study assumes a constant value of Rh for the orchard life cycle ( $3106 \text{ kg DW C ha}^{-1}\text{yr}^{-1}$ ) considering local soil characteristic and weather (removal or not of fruit, wood and pruning residual, sudden rains, etc.) condition according to Montanaro et al. (2017). Moreover, biomass leaved on the soil is represented by weeds, shoots, leaves and cherries. The latter are fruits not conform for processing and for sale corresponding on about 5% of total sweet cherries harvested.

**Table 16: Carbon balance of sweet cherry orchard (data are expressed in  $kg\ DW\ C\ ha^{-1}yr^{-1}$ )**

Biomass			1 <sup>st</sup> growing- phase	2 <sup>nd</sup> growing- phase	Full production
			$kg\ DW\ C\ ha^{-1}yr^{-1}$		
NPP <sub>tree</sub>	Above soil	FH	0	284.68	1186.18
		Pruning	20.98	41.95	597.46
		Cherry waste	0	20.50	61.40
		Leaves	100.76	201.52	826.32
		Woods <sub>yearly increment</sub>	260.04	520.08	2167.00
NPP <sub>Weeds</sub>	Below soil	Roots <sub>yearly increment</sub>	128.16	256.32	1068.00
	Above soil	Weeds <sub>Leaves and stuck</sub>	135.00	135.00	135.00
	Below soil	Roots	20.00	20.00	20.00
<b>NPP<sub>Total</sub></b>			<b>664.94</b>	<b>1480.05</b>	<b>6061.36</b>
R <sub>h</sub>			3106	3106	3106
<b>NEP</b>			<b>-2441.06</b>	<b>-1625.95</b>	<b>2955.36</b>
<b>LTC</b>		OF	1712.23	1712.23	1712.23
<b>NECB</b>			<b>-728.83</b>	<b>86.28</b>	<b>4667.59</b>

Source: Personal elaboration

The total carbon fixed by chlorophyll photosynthesis during the life-cycle of a cherry orchard to 1<sup>st</sup> growing phase (6 years) to full production phase (14 years) is 63418.55  $kg\ DW\ C\ ha^{-1}$  (a part from plant respiration - R<sub>h</sub> - 62120  $kg\ DW\ C\ ha^{-1}$ ).

The present study not consider the nursery phase (2 years) on Cb, because it affecting less than 1% the total NECB and therefore negligible. Therefore, the biomass which contribute to improve SOC in the soil was represented by pruning and cheery waste, leaves, roots, weeds and organic fertiliser – OF – is equal to 59294.18  $kg\ DW\ CO_2\ ha^{-1}$  (table 16). According to Ingrao et al. (2015) this biomass contributes to enrichment the soil of Carbon representing a sink. Regarding cherries are eating by consumer and consequently transformed carbon (17460.57  $kg\ DW\ C\ ha^{-1}$ ) in CO<sub>2</sub> by human digestion as well as woods and roots (48783.80  $kg\ DW\ C\ ha^{-1}$ ) used as fuel after dismantling. Therefore, these CO<sub>2</sub> was considered carbon neutral since its balance is equal to zero or close to it.

### 2.3.6 GHG emissions from orchard management and transport of materials and workers

As already describe in the present study the system boundaries include several activities starting from nursery phase to processing phase. The latter is performed in the collected centre where the sweet cherries are packed in a clamshell for the fresh market (Figure 13). In particular

orchard management consider all the fuel consumption connect with activities performed during the cultivation of cherries such as mineral administration, ploughing, pruning, etc. The transport flow asses the fuel consumption to transfer workers from home to workplace and vice versa and to transport all materials from production firm to the cherry orchard and collecting centre. Furthermore, it has been also taken into account the transport of cherries harvested from orchard to the processing. According to Tricase et al. (2017) the diesel consumption in the orchard management and in the transport of workers and materials is equal to 9379.62 L (Figure 14 and 15).

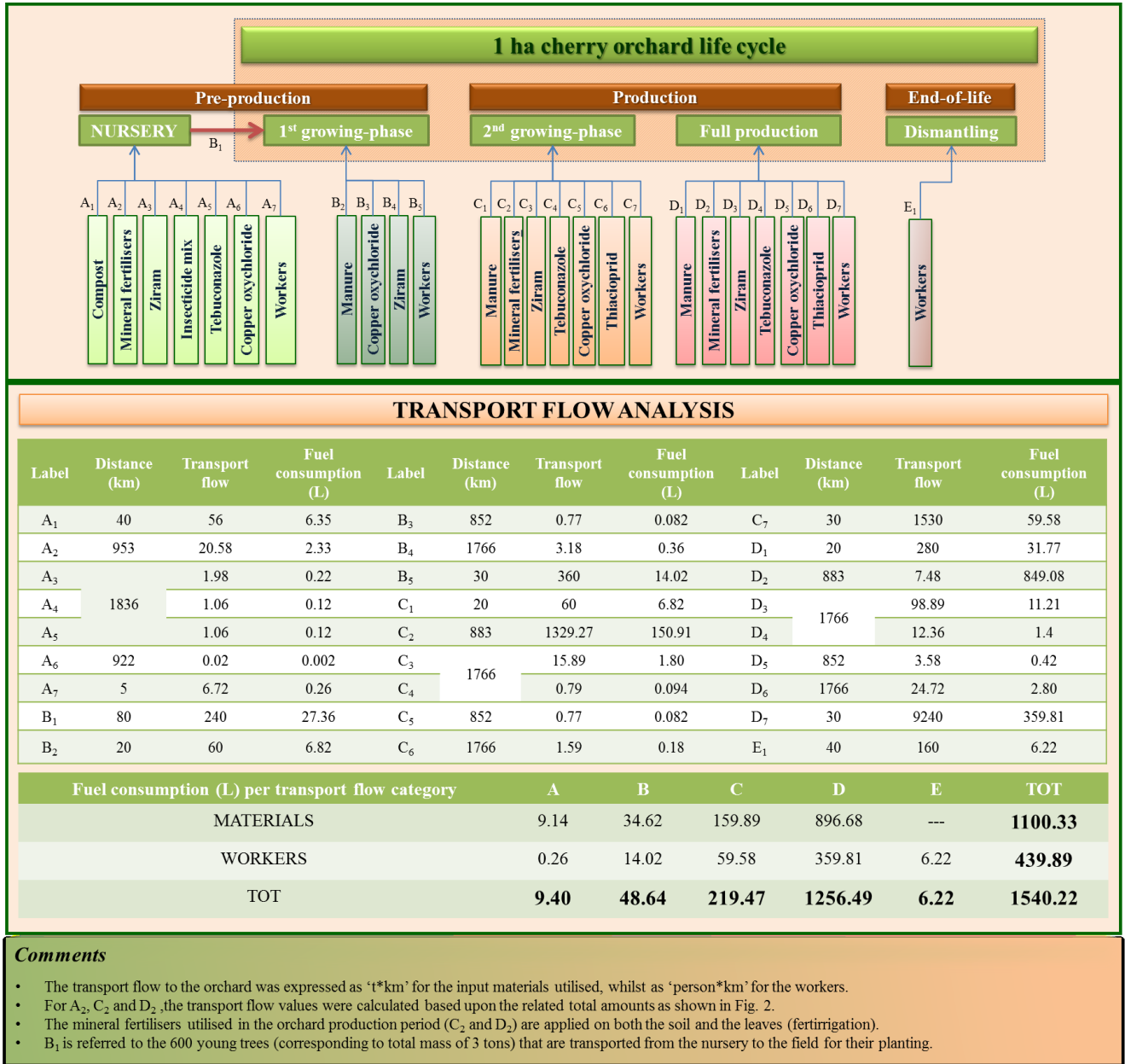

**Figure 15: Transport flow and related fuel consumption associated with the materials and workers involved in each phase of the orchard life-cycle<sup>12</sup>**

The transport flow of cherries harvested was calculated with follow equation:

$$TF_{MC} = D_{RT} \times D \tag{1}$$

Where:

<sup>12</sup> Tricase, C., Rana, R., Andriano, A. M. and Ingrao, C., 2017. An input flow analysis for improved environmental sustainability and management of cherry orchards: A case study in the Apulia region. Journal of Cleaner Production. 156, 766-774. DOI: 10.1016/j.jclepro.2017.04.088.

- $TF_{MC}$ : transport flow related to the cherries harvested, expressed as t\*km (extrapolated from Ecoinvent, 2011);
- $T_A$ : total amount of sweet cherry harvested (t)
- $D$ : distance from the orchard to collected centre (km).

As regards transport flow connect with the processing phase it was calculated considering the equations 2 for worker:

$$TF_{WP} = N_{WP} \times D_{RT} \times N_Y \quad (2)$$

Where:

- $TF_{WP}$ : transport flow associated with the workers from home to workplace and vice versa, expressed as person\*km. The worker are local individuals and arrive from the neighbouring areas, travelling for an average of 10 e15 km to reach the collected centre;
- $N_{WP}$ : number of workers in the processing phase and equal to 20 persons;
- $D_{RT}$ : total roundtrip distance from the workers' houses to the collected centre (km).

Finally, the consumption of fuel related the total transport flow for worker and PET clamshell and cherries was assess using the conversion factors of Ecoinvent (2011) and the following equation according to Tricase et al. (2017):

$$FC = TF \times CoFac \quad (3)$$

where

- $FC$ = fuel consumption ( $L_{Diesel}$ ) associated with the  $TF$  calculated according to Ecoinvent (2011) for the PET clamshell, cherries, and for the workers;
- $CoFac$  is the conversion factor considered, equal to 0.026  $L_{Diesel}/kg*km$  for the PET clamshell (transport on road) and 0.0025  $L_{Heavy\_fuel-oil}/kg*km$  (transport transoceanic freight ship), 0.114  $L_{Diesel}/kg*km$  for cherries harvested and 0.0398  $L_{Diesel}/person*km$  for the workers (extrapolated from Ecoinvent, 2011). In particular these conversion factors are based for the material production of clamshell on “Transport, transoceanic freight ship/OCE S” and “Transport, lorry >32t, EURO4/RER S” for the virgin resin, “Transport, lorry >32t, EURO4/RER S” for recycled resin and “Transport, lorry 3.5-7.5t, EURO4/RER S” for cherries harvested. As regards workers the study has considered “Transport, passenger car, diesel, EURO 5”.

Lastly the fuel consumptions associated with the agricultural management and transport activities of cherries production were summarised in table 17. Regarding the transport on road of 1 kg of PET clamshell the diesel consumptions was equal to 36.24L whereas the transport transoceanic freight ship it was 16.59 L of heavy fuel oil.

**Table 17: Diesel consumption from agriculture management and transport of materials and workers based on the total cherries production**

Category	Diesel consumption L
Orchard management	7199.18
Material (to orchard)	1100.33
Workers (to orchard)	439.89
Workers (to collected centre)	23.91
Sweet cherry harvested (to collected centre)	392.53
<b>Total</b>	<b>9155.84</b>

### 2.3.7 Processing phase

The harvesting phase is followed by the transport of sweet cherries to the collected centre where they are processed and packed in a clamshell made in PET (fig.1). Consequently, to calculate sweet cherry CF, the study has included in the system boundaries also PET clamshell production phase with their relative transfer to the collected centre. The processing phase is characterised principally by the energy consumption derived processing of 228 t of sweet cherry in the processing room and hydrocooler as reported in table 18. Moreover, the production of clamshell is characterised by the use of both virgin resin and recycle PET following by extrusion and thermoforming process (Figure 13). Finally, data of processing phase was obtained directly from local firm whereas clamshell production (i.e. extraction of natural resources, energies and fuels consumption) from Ecoinvent (2011) modules for PET clamshell production.

**Table 18: Energy consumption kWh from processing phase considering the total cherry production 228 t**

Category	Energy consumption kWh
Hydrocooler	6110.40
Calibration	3853.20
Processing room	6566.40
Cold storage	977.14
Packaging	1021.44
<b>Total</b>	<b>18528.58</b>

## 2.4 Results and discussion<sup>13</sup>

The research highlight that the GWP<sub>100</sub> associated with the system investigated is equal to 0.798 kg CO<sub>2eq</sub> per 0.5 kg of fresh sweet cherry packed in PET clamshell.

As show by Figure 16 and 17 the most impacting processes are:

- “processed cherries” for 90.7% (0.724 kg CO<sub>2eq</sub>) that include the “cherry agriculture management”. The latter contributed for 82.2% and is equal to 0.656 kg CO<sub>2eq</sub>;
- “clamshell PET” regarding the production of clamshell made in PET and is equal to 0.0744 kg CO<sub>2eq</sub> (contributing for 9.31%);

---

<sup>13</sup> Tricase, C., Rana, R., Andriano, A. M. and Ingraio, C., 2017. An input flow analysis for improved environmental sustainability and management of cherry orchards: A case study in the Apulia region. *Journal of Cleaner Production*. 156, 766-774. DOI: 10.1016/j.jclepro.2017.04.088.

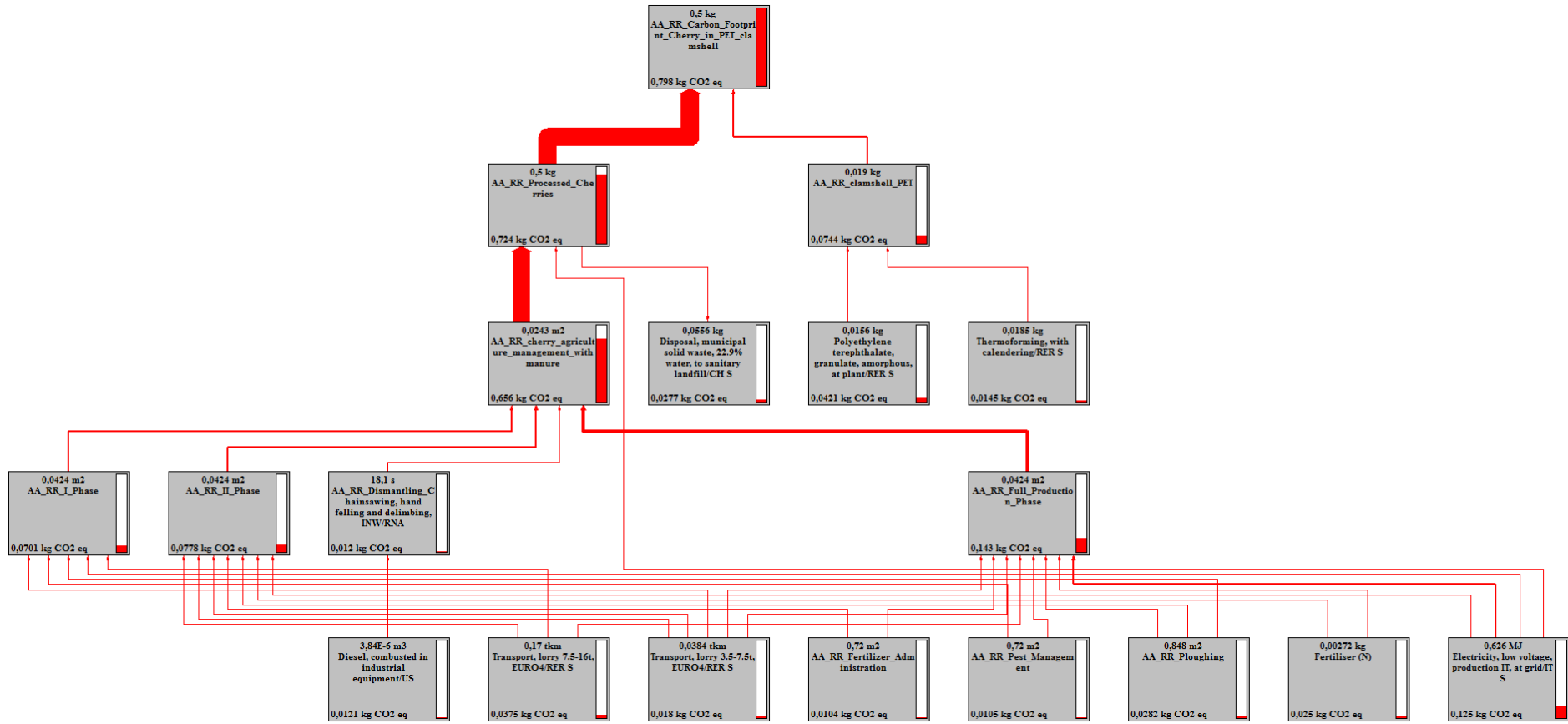

Figure 16: Sankey diagram (kgCO<sub>2</sub>eq) - (FU: 0.5 kg of fresh sweet cherry packed in PET clamshell)



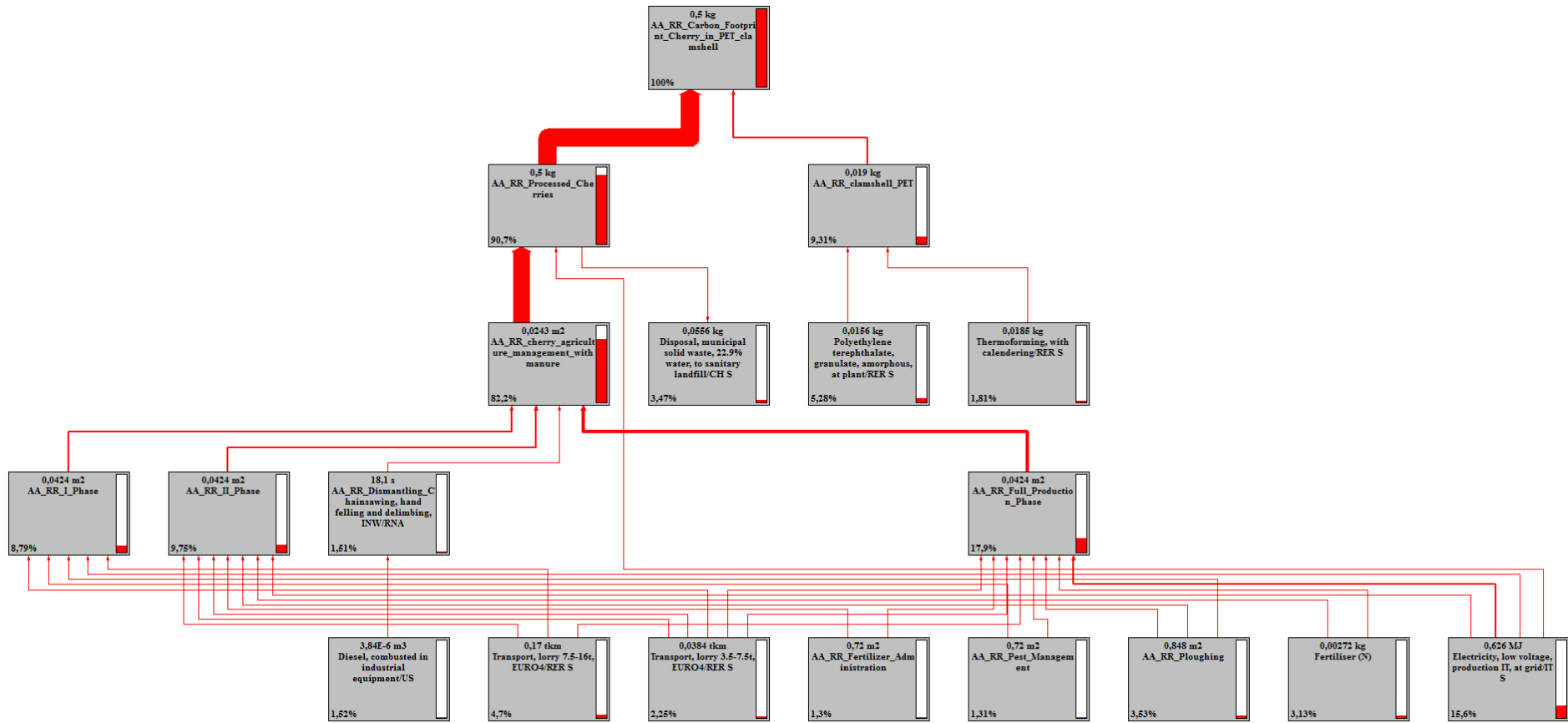

Figure 17: Sankey diagram (%) – (FU: 0.5 kg of fresh sweet cherry packed in PET clamshell)

For a greater understanding of the system boundaries reported in Figure 13, the impact assessment of each eco-balance was observed based on the FU of the main processes of sweet cherry supply chain. Successively, each process was attributed to the principal FU (0.5 kg of sweet cherry packed in PET clamshell).

As regard the orchard management (1 ha cherry orchard, FU), the Figure 19 and 20 showed that significant  $GWP_{100}$  impact come from the full production phase for 21.8% due to the huge consumption of chemicals, water and fuels which, apart from the specific requirements of the trees, are dependent upon the greater time-span (14 years) of this phase compared to the previous ones.

Other impacts come from:

- the nursery, due to the number of farming treatments required for plant growth, though the amounts of chemicals, water and fuels remain lower than the next phases. The  $GWP_{100}$  is equal to  $1.33E3 \text{ kgCO}_{2\text{eq}}$ ;
- the first growing phase, as characterised by a reduced number of agricultural activities with respect to the other phases, despite of the relatively high amounts of manure, pesticides, waters and fuels used. The  $GWP_{100}$  is equal to  $2.88E4 \text{ kgCO}_{2\text{eq}}$ ;
- the second growing phase, because of the greater number of treatments performed with the subsequent greater amounts of water, chemical and organic products administered and fuel consumed, compared to the previous phases. The  $GWP_{100}$  is equal to  $3.2E4 \text{ kgCO}_{2\text{eq}}$ ;
- the end-of-life due to the consumption of the diesel required for the orchard dismantling. The  $GWP_{100}$  is equal to  $4.94E3 \text{ kgCO}_{2\text{eq}}$ .

In particular, from Figure 14 it results that the full production phase contributes for 82% to the total consumption of water (for irrigation and dilution) associated with the orchard life-cycle, including the nursery phase. Also, Figure 14 shows that, from phase to phase the irrigation and dilution water consumption increases, due to the cultivation system adopted (i.e. irrigation, fertilisation and pest management) based upon the plantation requirements, as well as the time-span of each phase. The related annual values were extrapolated from Figure 14 and resulted as ranging between:

- $125$  (in the nursery) and  $2000 \text{ m}^3$  in the full production period, for the irrigation water; and
- $0.3$  (in the first growing phase) and  $10.43 \text{ m}^3$  in the full production period, for the dilution water.

With regard to the fuel-consumption issue, it can be asserted that the full production period is the most responsible of the total fuel consumption associated with the orchard life-cycle. As for the water, the fuel consumption trend in the orchard life-cycle is affected not only by the given cultivation system but also by the time-span of each composing phase. Moreover, diesel fuel

consumption significantly increases over the whole orchard cultivation (transport flows included) due to the changes occurring in the cultivation practices as a consequence of the plantation growth and cherry production. In particular, the most fuel demanding processes are the followings:

- the tillage operations for the first growing phase with a 360 L consumption;
- pest management for the second growing phase contributing for ~420 L;
- mineral fertilisation in the full production period with a consumption of nearly 1890 L;
- organic fertilisation (manure) in the full production phase with a consumption of 1616 L.

Another consideration is that the manure affects the GHG emission due to the transport of 25 t from the production area to the orchard. Therefore, the advantages deriving from the addition of organic fertilizer in the soil are thwarted by their transport.

It should be noticed that tillage hugely contributes to fuel consumption related to the orchard management with an average annual consumption equal to 29 L corresponding to 180 L and 81 L in the first and second growing phase, and 317 L in the full production period.

As regard the Cb, the full production phase determines an accumulation of carbon deriving from an increase of leaves and pruning residues in the soil (12660.37 kgCO<sub>2</sub>). On the contrary, in the I and II phase the carbon accumulation is less than Rh causing the release of CO<sub>2</sub> (-12299 kgCO<sub>2</sub> and -10732.59 kgCO<sub>2</sub> respectively). Therefore, in the final balance the Rh is major on carbon accumulation and equal to -10370.76 (Table 16). Figure 18 shows the GHG emission from each agricultural phase and highlight the accumulation of carbon in the soil during the full production phase.

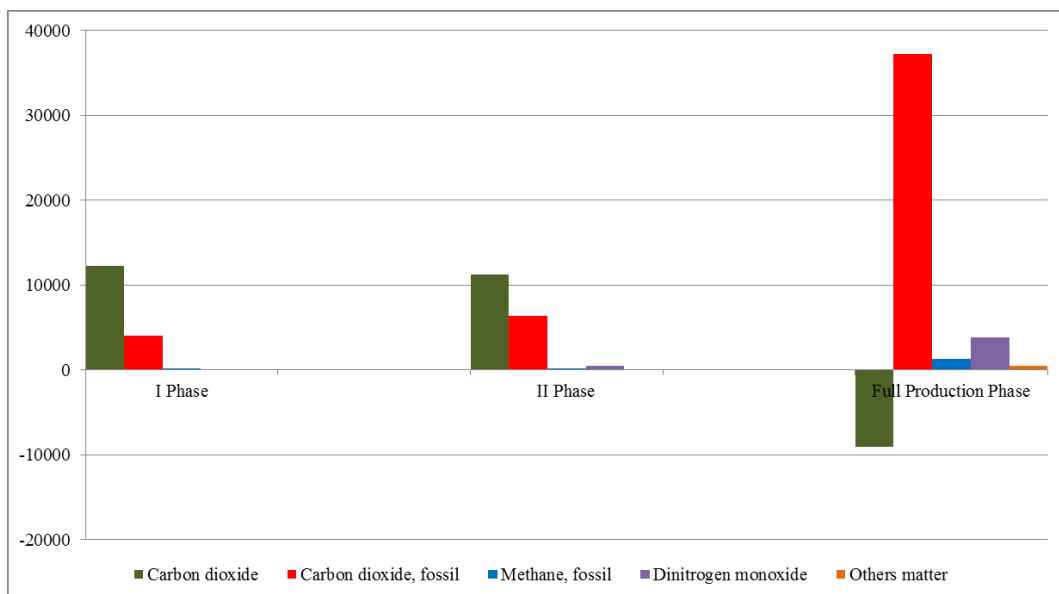

**Figure 18: GHG emission from each agricultural phase (kgCO<sub>2</sub>)**

Thanks to these results, the present study highlighting that pre-production phase (characterised by not production) represent the phase major affecting the Cb. Therefore, it is fundamental considering the orchard production all life cycle since focus only one year of cherry management could determine an assessment not compliance with reality.

Probably this value of Rh could be reduced by introducing conservative agriculture techniques (such as no-tillage) to reduce soil ploughing and therefore respiration, that is the oxidation of carbon present in organic matter.

As clarified in Figure 14, electricity demand comes from the utilisation of the groundwater pumping station for the irrigation and fertigation activities, with a consumption factor of 0.883 kWh<sub>e</sub> per m<sup>3</sup> of water extracted. For this reason, the related consumption trend follows that of the water and, indeed, is characterised by a peak in the full production period with the related value representing the 82% of the overall consumption. The GWP<sub>100</sub> is equal to 3.79E4 (14.1%) per FU 1 ha sweet cherry orchard (Figure 19 and 20).

Finally, the GWP<sub>100</sub> associated with the orchard management phase (FU: 1 ha cherry orchard) is equal to 2.7E5 kg CO<sub>2eq</sub>.

In agreement with Pergola et al. (2013), this study believe that the knowledge upon the water, material, fuel and energy inputs is essential in LCAs and other related studies, because it represents the starting point to find and develop ways for more efficient and sustainable usages in agriculture. This emphasises further upon the importance of studies, like the one discussed in this paper, aimed at the accounting and analysis of the aforementioned inputs to optimise both assessment and improvement of environmental sustainability and management. In this way, there would be mainly: reduced exploitation of natural and primary energy resources; reduced emissions of GHG and other gases (mainly affecting human health and the ecosystem quality); and enhanced environmental sustainability of orchard farming systems.

As previously documented, studies on environmental assessment of cherry orchard are very few. Furthermore, because agricultural activities are typical of every single territory, comparisons between different cherry production areas are not always doable. Consequently, by comparing the present study to those carried out by Demircan et al. (2006) and Kizilaslan (2009) several differences were highlighted. In particular, the latter consider, for instance, the hours spent by the farmers (human labour) to produce cherries, whilst the former accounts for the consumption of diesel to move the employees from their home territories to the orchard. Therefore, by applying the specific energy equivalent values proposed in the previous studies to the inputs of the present (the

labour inputs were considered as work hours) it can be stated that the more intensive activity was the fertilisation use in Turkey, whilst diesel consumption in Italy (see Table 19). Such can be attributed to the fact that the majority of agricultural activities in Turkey are performed manually and huge amounts of fertilisers and water are administered and consumed by farmers, mainly because of the local soil and climate conditions. For contrast, the Italian agriculture is much more centred upon the utilisation of agricultural machineries in the majority of the activities involved, in order to maximise yields and qualities of the products, as well as the management system. Moreover, the other outputs are comparable each other, demonstrating that similar cultivation. The research suggests the introduction of intelligent machines and autonomous vehicles to agricultural operations (such as tractors hybrid, electric agricultural machines or innovative multi-functional agricultural machinery) able to speed up the agricultural management operations reducing both energy and fuel consumption and environmental impacts (Bortolini et al., 2014; Bochtis et al., 2014).

**Table 19: Comparison of energy input ratio between the present study and Turkish research during the full production**

Inputs	Unit	Energy equivalent	Amount of input used per hectare (ha)	Total energy input	Percentage of the total energy input (present study)	Percentage of the total energy input (Turkish studies)
		(MJ unit <sup>-1</sup> )	-	(MJ ha <sup>-1</sup> )	(%)	(%)
Extrapolated from Demircan et al. (2006)						
1. Chemicals					<b>3</b>	<b>2</b>
<i>Fungicides</i>	kg	216	67.2	14515.20		
<i>Insecticides</i>	kg	101.2	14	1416.80		
2. Labour	h	2.3	2889	6644.70	<b>1</b>	<b>2</b>
3. Material transport	L	56.31	896.68	50492.05	<b>9</b>	<b>5<sup>a</sup></b>
4. Fertiliser					<b>12</b>	<b>42</b>
<i>Nitrogen fertiliser (N)</i>	kg	66.14	574	37964.36		
<i>Phosphorus (P<sub>2</sub>O<sub>5</sub>)</i>	kg	12.44	854	10623.76		
<i>Potassium (K<sub>2</sub>O)</i>	kg	11.15	1414	15766.10		
Manure	tons	303.1	14	4243.40		
5. Diesel	L	56.31	6160	346869.60	<b>59</b>	<b>21</b>
6. Electricity	kWh	3.6	24853	89470.80	<b>15</b>	<b>22</b>
Extrapolated from Kizilaslan, (2009)						
1. Chemicals	kg	101.2	81.2	8217.44	<b>1</b>	<b>1</b>
2. Labour	h	2.3	2889	6644.70	<b>4</b>	<b>13</b>
3. Material transport	L	56.31	896.68	50492.05	<b>9</b>	<b>5<sup>a</sup></b>
4. Fertiliser					<b>10</b>	<b>45</b>
<i>Nitrogen fertiliser (N)</i>	kg	60.6	574	34784.40		
<i>Phosphorus (P<sub>2</sub>O<sub>5</sub>)</i>	kg	11.1	854	9479.40		
<i>Potassium (K<sub>2</sub>O)</i>	kg	6.7	1414	9473.8		
5. Manure	kg	0.3	14000	4200	<b>1</b>	<b>3</b>
6. Diesel	L	56.31	6160	346869.60	<b>6</b>	<b>22</b>
7. Electricity	kWh	3.6	24853	89470.80	<b>16</b>	<b>11</b>

<sup>a</sup>Tractor and machinery

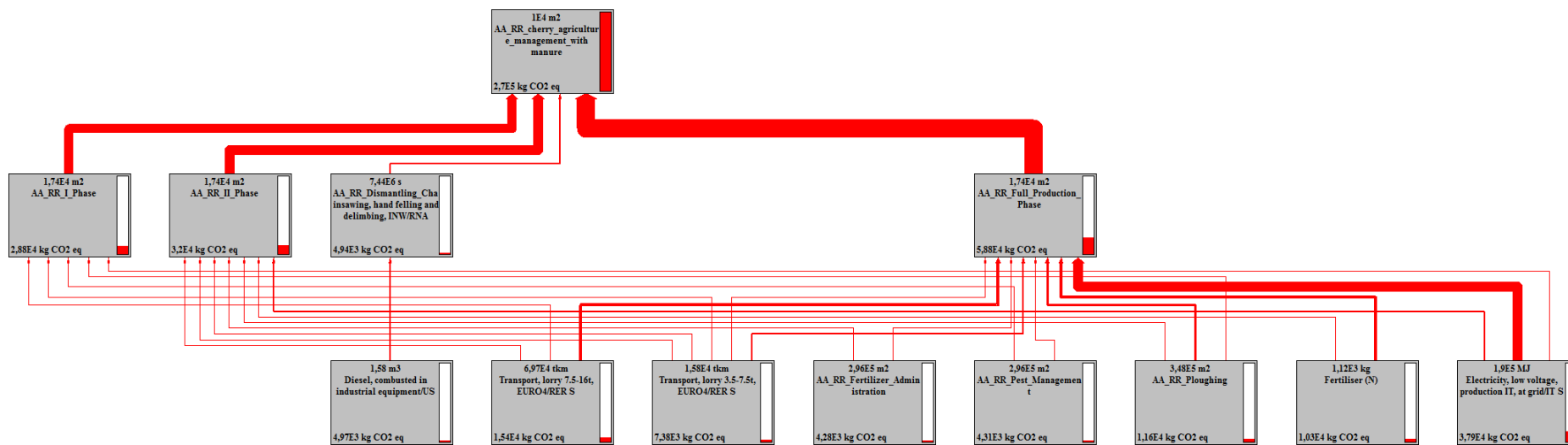

Figure 19: Sankey diagram (kgCO<sub>2</sub>eq) - (FU: 1 ha sweet cherry orchard).

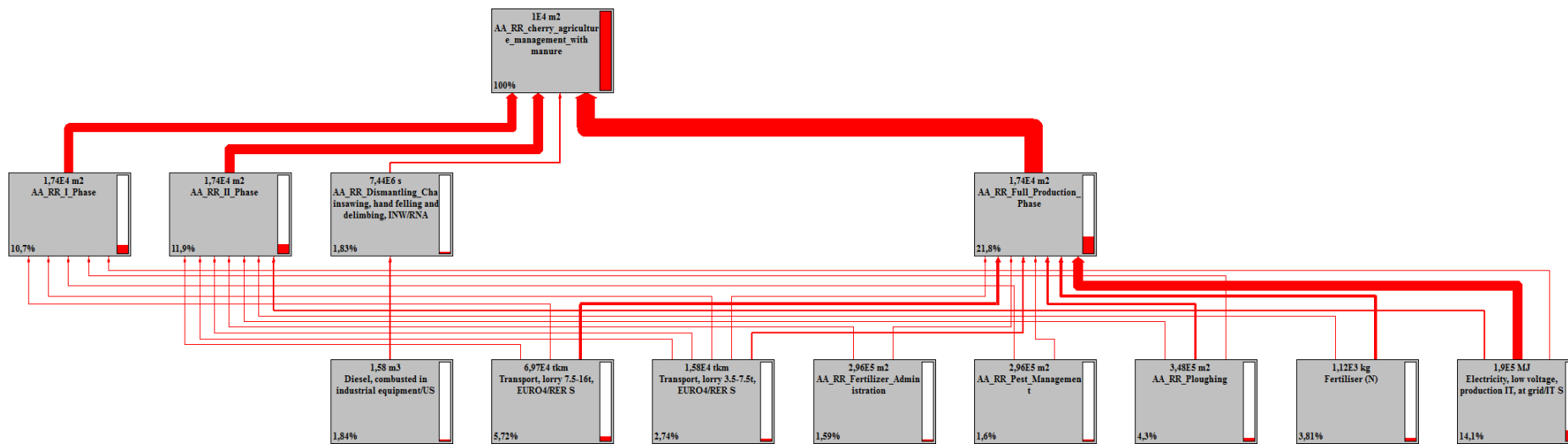

Figure 20: Sankey diagram (%) - (FU: 1 ha sweet cherry orchard)



As regard the processing phase the GWP<sub>100</sub> associated with FU equal to 1 kg of cherries processed amount to 1.45 kg CO<sub>2eq</sub> (Figure 21). In this phase the cherries harvested coming from the orchard to the collected centre where they are processed during the day and destined to the trade. These cherries are worked using the following treatment: hydrocooling, calibration, selection, packaging, labelling and finally cold storage (Figure 13). Since sweet cherry is a very perishable fruit, after the harvesting, it is cool off in order to extending storage duration and shelf life and safeguarding quality of fruit. For this reason, when the sweet cherries arrive to the collection centre are firstly poured out in the hydrocooler which consists in a bed of cold water (0°C) where fruits are cooled and cleaned at the same time. Moreover, to sanitizer and to reduce microbial pathogens water is blend with potassium hypochlorite and potassium chloride. Then by a constant cold-water flow cherry is transferred to the calibration phase where peduncles are cut. At this stage fruits are selected by workers for the fresh market and cherries with damage are eliminated and those not conform to market requests are destined to other uses (e.g. jam production). Subsequently cherries are packaged using machines that weigh the exact amount for each package and finally it is labelled. All these phases are performed by 20 workers which cover 15 km to reach collected centre by car. Finally, cherries packet is transferred to the cold storage for maximum two days (at 0.5°C) before sending to the fresh market.

The processing phase is characterised principally by the energy consumption (18528.58 kWh) derived principally by the processing room and hydrocooler treatment as reported in table 18.

Moreover, the processing phase produced waste deriving by damaged or not conform cherries.

As show by Figure 21 and 22, a part the agriculture management phase, the most impact come from:

- “electricity” equal to 0.249 kg CO<sub>2eq</sub> (17.2%);
- “disposal, municipal solid waste” equal to 0.0554 kg CO<sub>2eq</sub> for 3,83%. This impact deriving from the waste produced during the cherry processing.

During this phase cherries not conform, peduncles or other scraps are sent by the collected centre to the landfill that contributing to the GHGs emission (i.e. methane, carbon dioxide and sulfur hexafluoride). For this reason, it is necessary to search an appropriate management of waste that reduce this impact. A possible solution could be the reuse of waste in alternative way such as a new raw material or a by-product for other process. Indeed, these wastes can be reused and recycled in alternative way (such as source of flavour or aroma compounds, antioxidants, natural colourants and dietary nutrients) and so it is possible suggest the collection centre to expand the processing line to other product line in order to enhance the cherry waste.

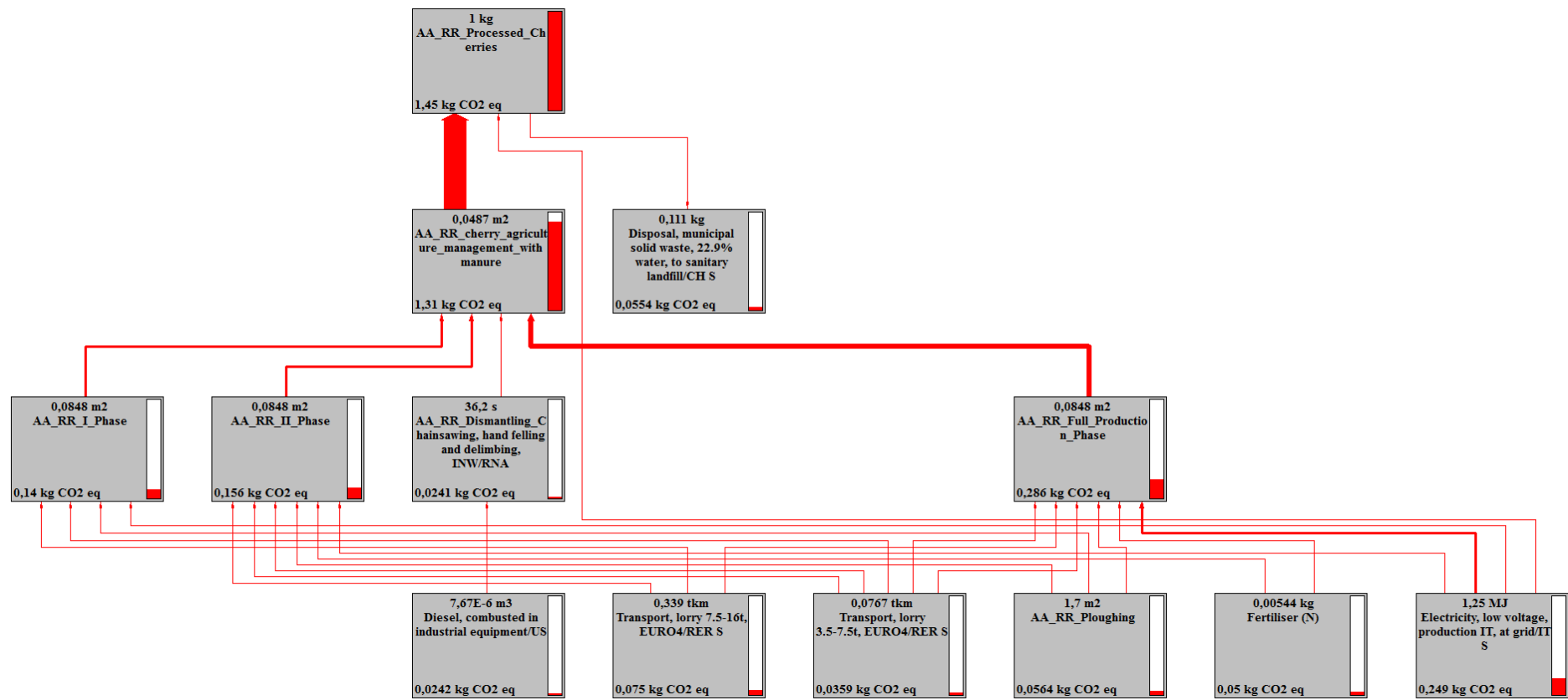

Figure 21: Sankey diagram (kg CO<sub>2</sub>eq) - (FU: 1 kg sweet cherry processed)

## Sustainability and innovation of the sweet cherry supply chain

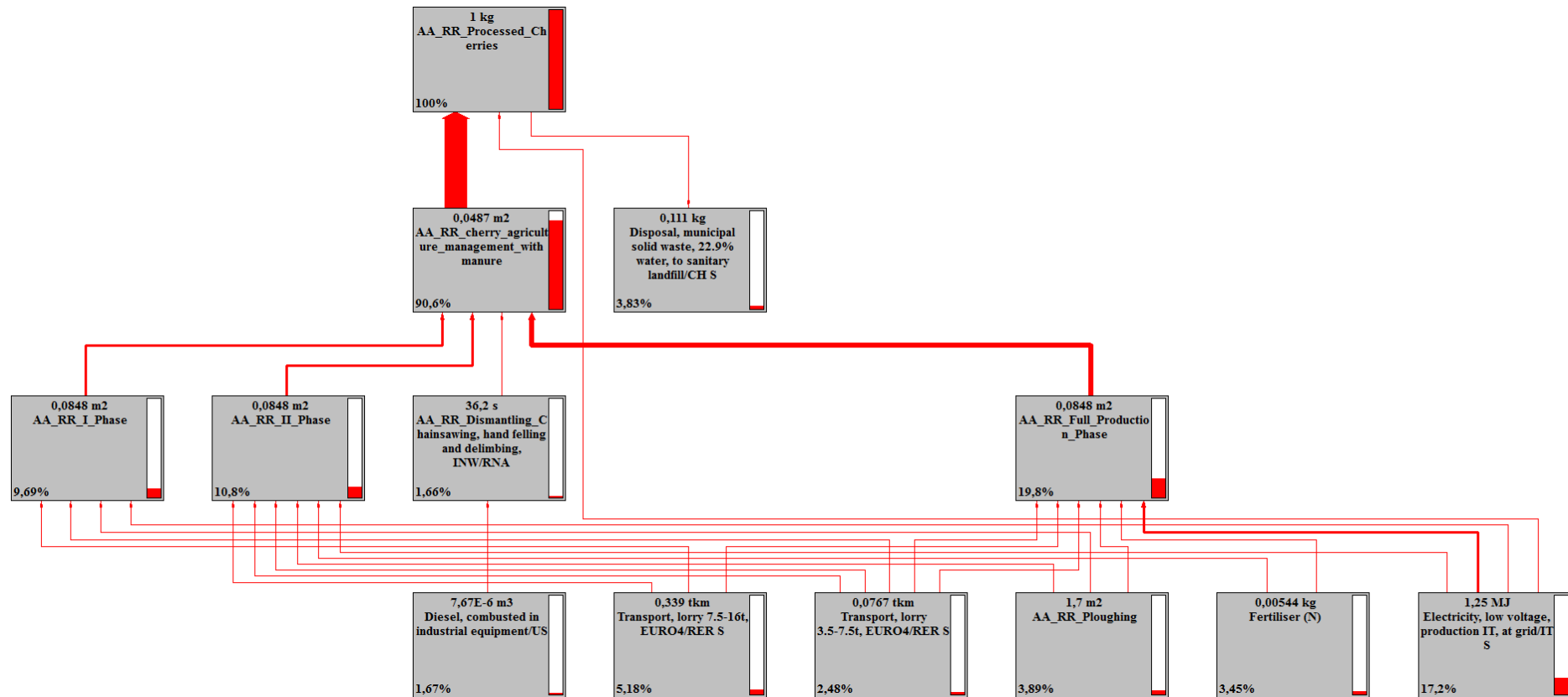

Figure 22: Sankey diagram (%) - (FU: 1 kg sweet cherry processed)

As above mentioned the study has investigated also PET clamshell production phase and their transfer to collected centre. The GHGs emission of this eco-balance is assessed in association with the materials, energies and processes characterising the analysed system. The system boundaries of PET clamshell production include virgin resin production, recycled PET manufacture and PET scrap (Figure 23). The latter deriving from extrusion and thermoforming process. PET clamshell is produced by a company located in Rutigliano. For the purpose of the present research, the FU is equal to 1 kg of PET clamshell production. Moreover, the allocation has based on mass criteria and is equal to 95.36% for PET clamshell and 4.65% for PET scrap.

As regard the materials transfer, the transport of virgin resin is carried out from Suape – Brazil (where the material is produced) to Rotterdam (7685 km) with a ship (maritime transport). Successively, from Rotterdam to Rutigliano (operational headquarters of PET recycled and clamshell production company) the transport is on the road (1543 km). Finally, PET clamshells are transfer from Rutigliano to Bisceglie (collected centre) with the road transport.

As far as the contribution of  $GWP_{100}$  per 1 kg of PET clamshell production is equal to 3.91 kg  $CO_{2eq}$  (Figure 24 and 25) and it is due to:

- PET granulate for 2.22 kg  $CO_{2eq}$  (56.7%). This phase is the highest contributors in this process;
- Thermoforming process for 0.762 kg  $CO_{2eq}$  (19.5%);
- Extrusion process for 0.524 kg  $CO_{2eq}$  (13.4%);
- Recycled PET pellet for kg 0.197  $CO_{2eq}$  (5.03%);
- Transport lorry for 0.145 kg  $CO_{2eq}$  (3.71%);
- Electricity consumption for the processing for 0.137 kg  $CO_{2eq}$  (3.51%)
- Recycled PET flake for 0.13 kg  $CO_{2eq}$  (3.32%);
- Transport, transoceanic freight ship for 0.0677 kg  $CO_{2eq}$  (1.73%).

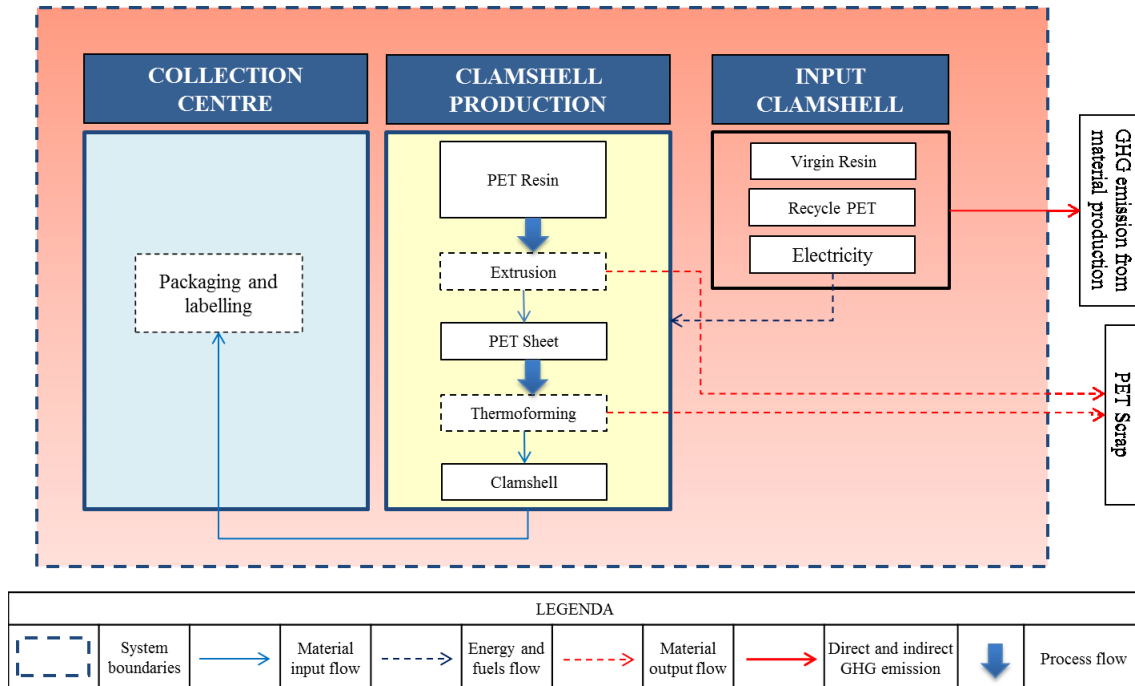

**Figure 23: System boundaries of PET clamshell production**

The study showed that the main impact is caused by used of PET granulate. Probably this use could be reduced using more recycled PET or alternative packaging (such as edible coating).

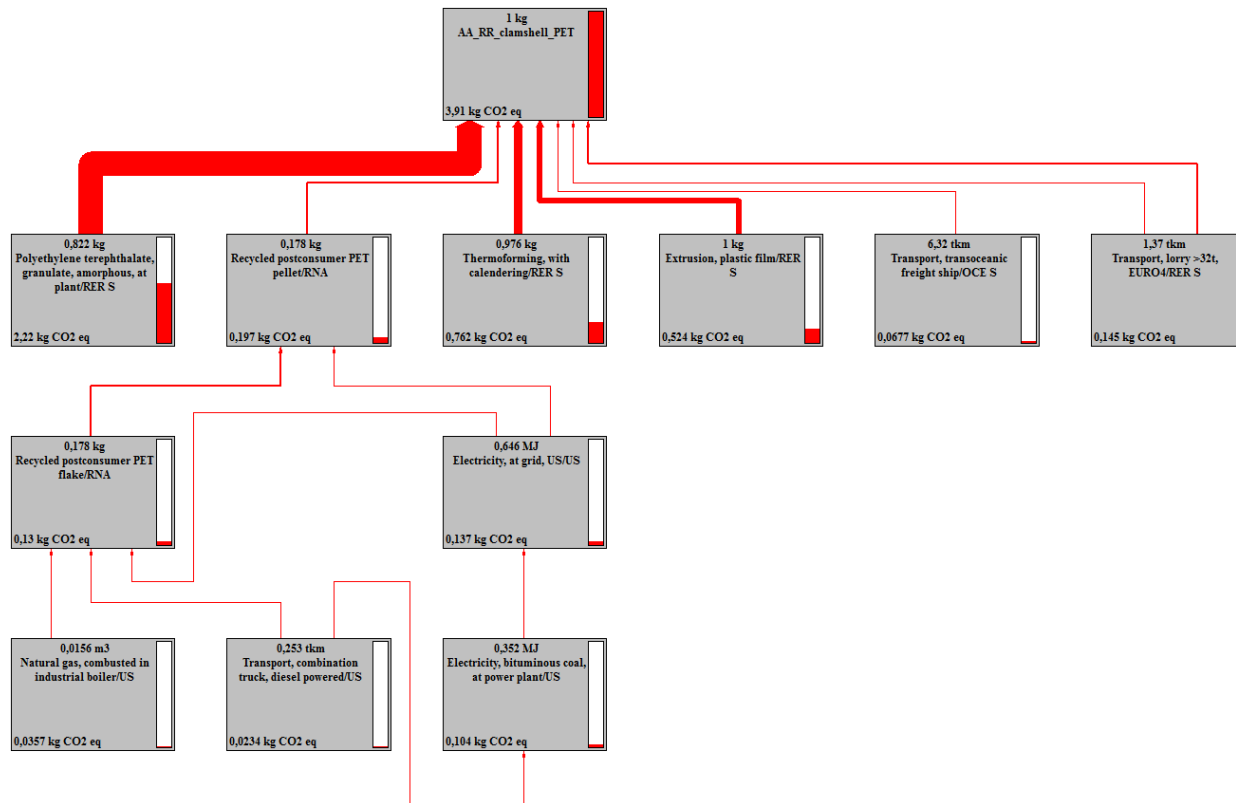

Figure 24: Sankey diagram (kgCO<sub>2</sub>eq) - (FU: 1 kg PET clamshell)

## Sustainability and innovation of the sweet cherry supply chain

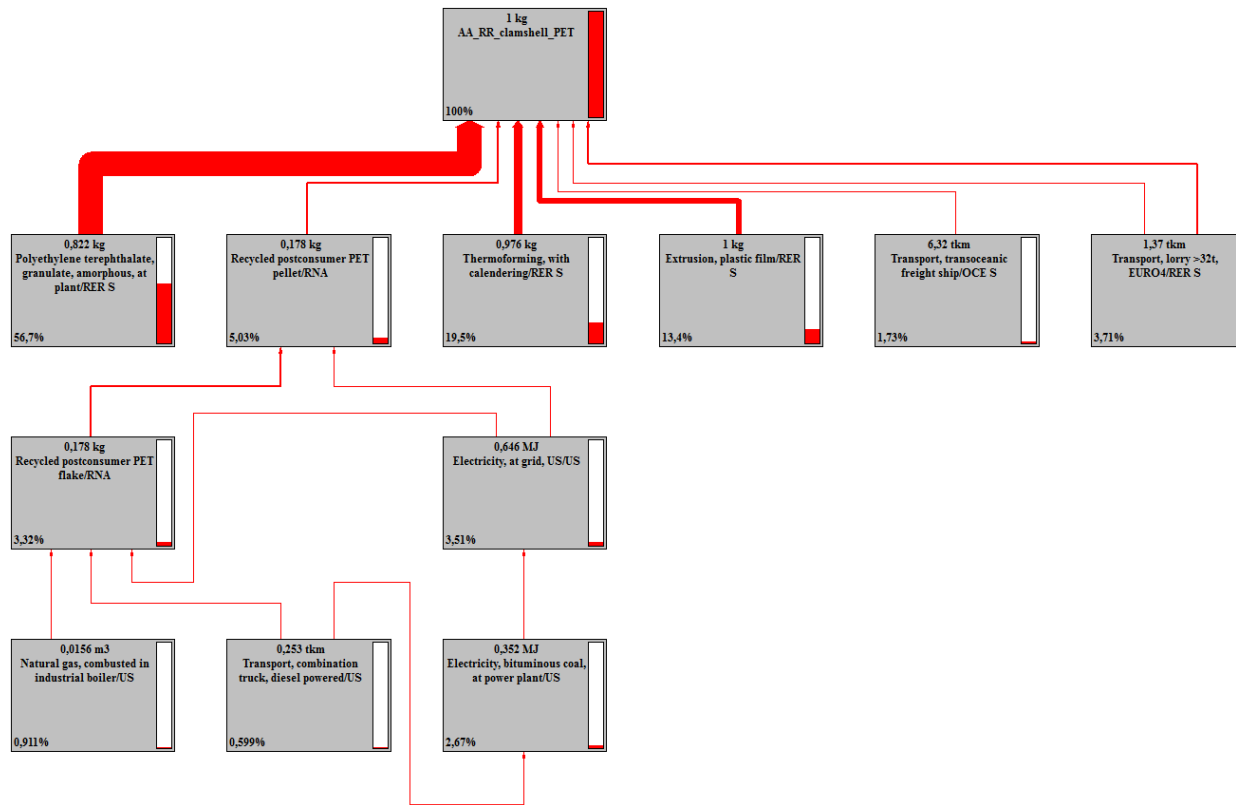

Figure 25: Sankey diagram (%) - (FU: 1 kg PET clamshell)

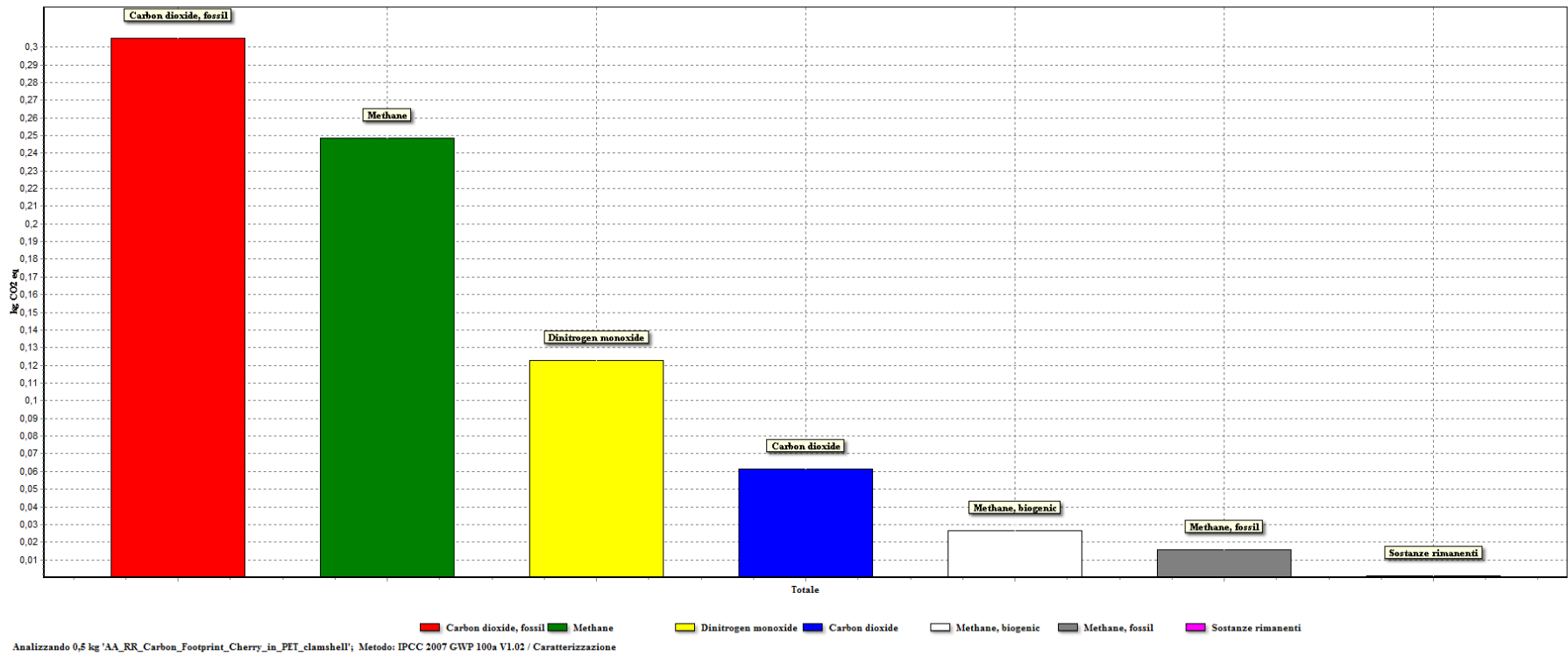

Figure 26: contributing GHGs (FU: 0.5 kg of cherry packed in PET clamshell)



Figure 26 shows the most GHGs that contributing to the total PCF indicating for each of them, the related  $GWP_{100}$  value expressed as  $kgCO_{2eq}$  per 0.5 kg of cherry packed in PET clamshell. The figure highlighted that carbon dioxide (fossil) and methane are the GHGs with the highest  $GWP_{100}$  value (40.3% and 31.1% respectively). During the “Full Production Phase” there are advantages deriving from the addition of organic fertilizer (manure administration) in the soil equal to 12660.37 kg. However, the benefits are thwarted by their transport. Probably these advantages could be increase using of sustainable agricultural machines for optimisation of farming system.

## CONCLUSIONS

The research has implemented the CF of sweet cherries supply chain assessing the GHG emissions associated with the system investigated (orchard management phase and processing cherry in a collected centre considering the PET clamshell production phase).

The study highlights that the GWP<sub>100</sub> associated with the system investigated is equal to 0.798 kg CO<sub>2eq</sub> per 0.5 kg of fresh sweet cherry packed in PET clamshell. In particular, the study shown that the impacts coming from the agricultural management stage is equal to 0.656 kgCO<sub>2eq</sub> and the processing is 0.068 kgCO<sub>2eq</sub>. As regard the orchard phase, the principal impact derives from the full production where the most GWP<sub>100</sub> impact is represented by the utilisation of the groundwater pumping station (electricity, low voltage production) for the irrigation and fertigation activities (15.6% of the total CO<sub>2eq</sub>), by the transport of manure (4.7% of the total CO<sub>2eq</sub>) and the ploughing (3.53% of the total CO<sub>2eq</sub>). Moreover, in the processing phase the PET clamshell production the contribution is equal to 0.0744 kgCO<sub>2eq</sub>.

As regard the Carbon balance, the full production phase determines a C sink deriving from the growth of the leaves and the increase of the quantity of pruning residues. In the I and II phase Rh is less than carbon accumulation activity. However, in the final balance the situation is changed: Rh is higher than the activity of carbon accumulation and so the soil represents a C source determining GHG emission. Probably this value of Rh could be reduced by introducing conservative agriculture techniques (such as no-tillage) to reduce soil ploughing and therefore respiration, that is the oxidation of carbon present in organic matter.

As already highlight the manure mainly affects the GHG emissions due to the relevant quantities transported from the production area to the orchard. Therefore, the advantages deriving from the addition of organic fertilizer in the soil are thwarted by the GHG emissions caused by their transport. A possible solution to reduce this environmental impact is to find a livestock firm near to the orchard.

As regard processing phase since it is use electricity only improving action is the installation of renewable energy power plant. Moreover, the study showed that the main impact from PET clamshell production is caused by used of PET granulate. Probably this use could be reduced using more recycled PET or alternative packaging (such as edible coating).

During the processing phase cherries not conform, peduncles or other scraps are sent by the collected centre to the landfill contributing produce waste. To reduce this impact, it is possible reuse reused and recycled in alternative way such as source of flavour or aroma compounds, antioxidants,

natural colorants and dietary nutrients. In this case the collection centre could expand the processing phase to other product line in order to reduce the cherry waste production and to enhance the firm income.

The research has carried out an overview of new technology highlighting that the use of agricultural by-product could decrease the consumption of synthetic and non-biodegradable materials for the packaging. For instance, edible coatings can represent a technology with low environmental impact since are used principally agricultural by-product. Therefore, edible coating can also satisfy both the consumers' demand and farmer income since the extension of shelf-life of fresh fruit can improve expand the sweet cherry market. However, the use of this edible-based coating requires further studies since some problems are still unsolved such as flavour alteration of fruit, scarce protection against external agents (e.g. bacteria, fungi, oxygen, etc.) and the presence of potential allergens.

In light of the above, the present study contributes to provide important information to stakeholders involved in the supply chain. In this way, the research can be used by farmers, food industry and policy planners, to promote or enhance the sweet cheery supply chain in terms of environmental sustainability. Moreover, the research has created a basis for developing a specific product certification (carbon labelling) that it takes into account sustainable practices adopted.

In this way, manufacturers have the opportunity to communicate to consumers (always more careful on this aspects) their sustainability policies improving the organization's reputation

## REFERENCES

- AA.VV, 2009. Il ciliegio in Puglia in Quaderno Ciliegio, ed. Centro di Ricerca e Sperimentazione in Agricoltura “Basile Caramia” di Locorotondo (BA). Italy, p. 128.
- Aday, M. S. and Caner, C., 2010. Understanding the effects of various edible coatings on the storability of fresh cherry. *Packaging Technology and Science*. 23: 441–456.
- Agri ISTAT e Istituto nazionale di statistica, agricoltura e zootecnia, 2015. Total Agricultural Production by Product Type and Year. Available online: [http://agri.istat.it/sag\\_is\\_pdwout/jsp/dawinci.jsp?q¼pLC170000030000173200&an¼2015&ig¼1&ct¼266&id¼15A|21A|30A](http://agri.istat.it/sag_is_pdwout/jsp/dawinci.jsp?q¼pLC170000030000173200&an¼2015&ig¼1&ct¼266&id¼15A|21A|30A) (Accessed 07 December 2016).
- Agri ISTAT e Istituto nazionale di statistica, agricoltura e zootecnia, 2017. Total Agricultural Production by Product Type and Year. Available online: [http://agri.istat.it/sag\\_is\\_pdwout/jsp/dawinci.jsp?q=plC170000030000173200&an=2017&ig=1&ct=266&id=15A|18A|21A|30A](http://agri.istat.it/sag_is_pdwout/jsp/dawinci.jsp?q=plC170000030000173200&an=2017&ig=1&ct=266&id=15A|18A|21A|30A) (Accessed 18 April 2017).
- Albuquerque, N., Garcia-Montiel, F., Carrillo, A., Burgos, L., 2008. Chilling and heat requirements of sweet cherry cultivars and the relationship between altitude and the probability of satisfying the chill requirements. *Environmental and Experimental Botany* 64, 162–170.
- Alonso, J., Alique, R., 2006. Sweet cherries. In *Handbook of fruits and fruit processing*. 359-367.
- Andriano, A.M., Ingrao, C., Tricase, C., 2015. The Role of Producers Organizations Association (POA) in Transnational Cooperation Projects. 8<sup>th</sup> EUROMED Conference Reading Book Proceedings “Innovation, Entrepreneurship and Sustainable Value Chain in a Dynamic Environment”, Verona, 16-18 September 2015, EuromedPress, 1936-1940. ISBN: 978-9963-711-37-6.
- Ansari, M., Davarynejad, G.H., 2008. Marked improvement of Hungarian sour cherries by cross-pollination II: fruit quality. *Asian Journal of Plant Sciences* 7 (8), 771–774.
- ANSES/Ciqual French food composition table version, 2012. <http://www.ansespro.fr/TableCIQUAL/index.htm>.
- Bagnato, G., Iulianelli, A., Sanna, A. and Basile, A., 2017. Glycerol production and transformation: A critical review with particular emphasis on glycerol reforming reaction for producing hydrogen in conventional and membrane reactors. *Membranes*. 7, 2, 17.

Ballistreri, G., Continella, A., Gentile, A., Amenta, M., Fabroni, S., Rapisarda, P., 2013. Fruit quality and bioactive compounds relevant to human health of sweet cherry (*Prunus avium* L.) cultivars grown in Italy. *Food Chemistry* 140 (4), 630–638.

Bastos, C., Barros, L., Dueñas, M., Calhelha, R.C., Queiroz, M.J.R.P., Santos-Buelga, C. and Ferreira, I.C.F.R., 2015. Chemical characterisation and bioactive properties of *Prunus avium* L.: The widely studied fruits and the unexplored stems. *Food Chemistry*, 173, 1045-1053.

Beattie, J., Crozier, A., and Duthie, G. G., 2005. Potential health benefits of berries. *Current Nutrition and Food Science*, 1, 71–86.

Beppu, K., Ikeda, T., Kataoka, I., 2001. Effect of high temperatures exposure time during flower bud formation on the occurrence of double pistils in ‘Satonishiki’ sweet cherry. *Scientia Horticulturae* 88, 77–84.

Bernalte, M.J., Sabio, E., Hernández, M.T., Gervasini, C., 2003. Influence of storage delay on quality of ‘Van’ sweet cherry. *Postharvest Biology and Technology* 28, 303–312.

Bessou, C., Basset-Mens, C., Latunussa, C., Vélul, A., Heitz, H., Vannière, H., Caliman, J.P., 2014. LCA of perennial crops: implications of modeling choices through two contrasted case studies. Schenck, R., Huizenga, D. (Eds.), 2014. *Proceedings of the 9<sup>th</sup> International Conference on Life Cycle Assessment in the Agri-Food Sector (LCA Food 2014)*, 8-10 October 2014, San Francisco, USA. ACLCA, Vashon, WA, USA.

Bessou, C., Basset-Mens, C., Tran, T., Benoist, A., 2012. LCA applied to perennial cropping systems: A review focused on the farm stage. *International Journal of Life Cycle Assessment*, 18, 2, 340-361.

Bieniek, A., Kawecki, Z., Kopytowski, J., Zielenkiewicz, J., 2011. Yield and fruit quality of Lithuanian sweet cherry cultivars grown under the climatic and soil conditions of Warmia. *Folia Horticulturae* 23 (2), 101–106.

Bilandzija, N., Voca, N., Kricka, T., Matin, A. and Jurisic, V., 2012. Energy potential of fruit tree pruned biomass in Croatia. *Spanish Journal of Agricultural Research*, 10, 2, 292-298.

Bochtis, D.D., Sørensen, C.G.C., Busato, P., 2014. Advances in agricultural machinery management: a review. *Biosyst. Eng.* 126, 69 - 81.

Borrello, M., Lombardi, A., Pascucci, S. and Cembalo, L., 2016. The seven challenges for transitioning into a bio-based circular economy in the agri-food sector. *Recent Patents on Food, Nutrition and Agriculture*. 8, 1: 39-47.

Bortolini, M., Cascini, A., Gamberi, M., Mora, C., Regattieri, A., 2014. Sustainable design and life cycle assessment of an innovative multi-functional haymaking agricultural machinery. *Journal of Cleaner Production*. 82, 23-36.

Bourtoom, T., 2008, Edible films and coatings: Characteristics and properties. *International Food Research Journal*. 15, 3: 237-248.

Bravo, G., López, D., Vásquez M., Iriarte, A., 2017. Carbon Footprint Assessment of Sweet Cherry Production: Hotspots and Improvement Options. *Polish Journal of Environmental Studies* 26, 2, 559-566.

Burkhardt, S., Tan, D.X., Manchester, L.C., Hardeland, R., Reiter, R.J., 2001. Detection and quantification of the antioxidant melatonin in ‘Montmorency’ and ‘Balaton’ tart cherries (*Prunus cerasus*). *Journal of Agricultural and Food Chemistry* 49 (10), 4898–4902.

Burt, S., 2004. Essential oils: Their antibacterial properties and potential applications in foods - A review. *International Journal of Food Microbiology*. 94, 3: 223-253.

Canadian Nutrient File database, 2012. <http://webprod3.hc-sc.gc.ca/cnf-fce/report-rapport.do?lang=eng>.

Cappelletti, G.M., Russo, C., Lopriore, G., Nicoletti, G.M., Scelsa, D., 2015. Conventional and organic farming methods of sweet cherry (*Prunus avium* L.) an environmental life cycle analysis approach. *Pol. J. Commod. Sci.* 4 (45), 70-79.

Catalano, L., Melillo, V.A., Laghezza, L., 2015. *Frutticoltura*. LXXVII. Considerazioni sulla filiera cerasicola: l’esperienza pugliese, vol. 4, pp. 8-13.

Cerutti, A.K., Beccaro, G.L., Bosco, S., De Luca, A.I., Falcone, G., Fiore, A., Iofrida, N., Lo Giudice, A., Strano, A., 2015. Life cycle assessment in the fruit sector. *Life Cycle Assessment in the Agri-food Sector*. Springer International Publishing, pp. 333-388.

Cerutti, A.K., Beccaro, G.L., Bruund, S., Bosco, S., Donno, D., Notarnicola, B., Bounousa, G., 2014. *Life Cycle Assessment Application in the Fruit Sector: State of the Art and Recommendations for Environmental Declarations of Fruit Products*, vol. 73, pp. 125-135.

Cerutti, A.K., Bruun, S., Beccaro, G.L., Bounous, G., 2011. A review of studies applying environmental impact assessment methods on fruit production systems. *J. Environ. Manag.* 92, 10, 2277-2286.

Cerutti, A.K., Bruun, S., Donno, D., Beccaro, G.L., Bounous, G., 2013. Environmental sustainability of traditional foods: the case of ancient apple cultivars in Northern Italy assessed by multifunctional LCA. *Journal of Cleaner Production*. 52, 245-252.

Chaovanalikit, A., Wrolstad, R.E., 2004. Anthocyanin and polyphenolic composition of fresh and processed cherries. *Journal of Food Science* 69 (1), 107–117.

Cheyrier, V., Gómez, C., Ageorges, A., 2012. In: Nollet, Toldrá (Eds.), *Flavonoids: Anthocyanins. Analysis of Active Compounds in Functional Foods*. CRC Press, Boca Raton, FL, pp. 379–404.

Chockchaisawasdee, S., Golding, J.B., Vuong, Q.V., Papoutsis, K. and Stathopoulos, C.E., 2016. Sweet cherry: Composition, postharvest preservation, processing and trends for its future use. *Trends in Food Science and Technology*, 55, pp. 72-83.

Commission Implementing Regulation (EU) No 543/2011 of 7 June 2011 laying down detailed rules for the application of Council Regulation (EC) No 1234/2007 in respect of the fruit and vegetables and processed fruit and vegetables sectors.

Commission Regulation (EC) No 214/2004 of 6 February 2004, laying down the marketing standard for cherries.

Connolly, D.A.J., Mchugh, M.P. and Padilla-Zakour, O.I., 2006. Efficacy of a tart cherry juice blend in preventing the symptoms of muscle damage. *British journal of sports medicine*, 40, 8, 679-683.

Contò, F., Fiore, M., La Sala, P., 2013. The role of innovation in the integrated processes of Integrated Project of Food Chain: the case of cherry cultivation chain in Apulia region. *Intellect. Econ.* 7, 467-485. 4(18).

Cordes, H., Iriarte, A. and Villalobos, P., 2016. Evaluating the carbon footprint of Chilean organic blueberry production. *International Journal of Life Cycle Assessment*, 21, 3, 281-292.

Crisosto, C.H., Crisosto, G.M., Metheney, P., 2003. Consumer acceptance of ‘Brooks’ and ‘Bing’ cherries is mainly dependent on fruit SSC and visual skin colour. *Postharvest Biology and Technology* 28, 159–167.

CRPA, 2012. Centro ricerche produzioni animali, 2012. Bovini da latte e biogas – Linee guida per la costruzione e la gestione degli impianti.

Dalgaard, T., Halberg, N. and Porter, J.R., 2001. A model for fossil energy use in Danish agriculture used to compare organic and conventional farming. *Agriculture, Ecosystems & Environment*, 87, 51–65.

Dang, Q.F., Yan, J.Q., Li, Y., Cheng, X.J., Liu, C.S. and Chen, X.G., 2010. Chitosan acetate as an active coating material and its effects on the storing of *Prunus avium* L. *Journal of Food Science*. 75, 2: S125–S131.

Database Spanish Food Composition (RedBEDCA), 2014.  
<http://www.bedca.net/bdpub/index.php>.

de Azeredo, H.M.C. 2012. Edible Coatings in Advances in Fruit processing technologies. Sueli R., Fabiano A.N.F., CRC Press 345-362.

Demircan, V., Ekinçi, K., Keener, H.M., Akbolat, D., Ekinçi, C., 2006. Energy and economic analysis of sweet cherry production in Turkey: a case study from Isparta province. *Energy Convers. Manag.* 47, 13, 1761-1769.

Dhall R.K., 2013. Advances in edible coatings for fresh fruits and vegetables: a review. *Critical Reviews in Food Science and Nutrition.* 53, 5: 435-450.

Díaz-Mula, H.M., Castillo, S., Martínez-Romero, D., Valero, D., Zapata, P.J., Guillén, F., Serrano, M., 2009. Sensory, nutritive, and functional properties of sweet cherry as affected by cultivar and ripening stage. *Food Science and Technology International* 15, 6, 535–543.

Díaz-Mula, H.M., Serrano, M. and Valero, D. 2012. Alginate coatings preserve fruit quality and bioactive compounds during storage of sweet cherry fruit. *Food Bioprocess Technology.* 5, 2990–2997.

Ding, E.L. and Mozaffarian, D., 2006. Optimal dietary habits for the prevention of stroke. *Seminars in neurology*, 26, 1, 11–23.

Ecoinvent, 2011. The Swiss Centre for Life Cycle Inventories. Ecoinvent v2.2.

Esti, M., Cinquanta, L., Sinesio, F., Moneta, E., Di Matteo, M., 2002. Physicochemical and sensory fruit characteristics of two sweet cherry cultivars after cool storage. *Food Chemistry* 76, 399–405.

European Commission, 2014. Towards a circular economy: A zero waste program for Europe, Commission 398 final, available on <http://eurlex.europa.eu/legal-content/EN/TXT/?uri=celex:52014DC0398> (Accessed 18 April 2017).

European Commission, 2015. Horizon 2020. Work Programme 2016 e 2017. [http://ec.europa.eu/research/participants/data/ref/h2020/wp/2016\\_2017/main/h2020-wp1617-food\\_en.pdf](http://ec.europa.eu/research/participants/data/ref/h2020/wp/2016_2017/main/h2020-wp1617-food_en.pdf) (Accessed 07 December 2016).

Fallahi, E., Righetti, T.L. and Proebsting, E.L., 1993. Pruning and nitrogen effects on elemental partitioning and fruit maturity in ‘bing’ sweet cherry. *Journal of Plant Nutrition*, 16, 5, 753-763.



Faniadis, D., Drogoudi, P.D., Vasilakakis, M., 2010. Effects of cultivar, orchard elevation, and storage on fruit quality characters of sweet cherry (*Prunus avium* L.). *Scientia Horticulturae* 125, 301–304.

FAO. 2011. Global food losses and food waste – Extent, causes and prevention. Rome.

FAOSTAT - Food and Agriculture Organization of the United Nations Statistics Division, 2017 available on <http://www.fao.org/faostat/en/#data/QC/visualize> (Accessed 18 April 2017).

FAOSTAT - Food and Agriculture Organization of the United Nations Statistics Division, 2015 available on. <http://faostat3.fao.org/browse/Q/QC/E> (Accessed 07 December 2016).

FAOSTAT - Food and Agriculture Organization of the United Nations Statistics Division, 2017 available on <http://www.fao.org/faostat/en/#data/QC/visualize> (Accessed 18 April 2017).

Faust, M. and D. Surányi. 1997. Origin and dissemination of cherry. *Hort. Rev.* 19:263-317.

Faust, M., Timon, B., Surányi, D.; Nyujtó, F.; Gradziel, T. M., 2011. Origin and dissemination of *Prunus* crops: peach, cherry, apricot, plum and almond. *Scripta Horticulturae* 11, 1-241.

Frischknecht, R., Rebitzerb, G., 2005. The Ecoinvent database system: a comprehensive web-based LCA database. *J. Clean. Prod.* 13, 1337-1343.

Gabriele, A., Continella, A., Gentile, M., Amenta, S., Fabroni, P., Rapisarda, 2013. Fruit quality and bioactive compounds relevant to human health of sweet cherry (*Prunus avium* L.) cultivars grown in Italy. *Food Chemistry*, 140, 4, 630-638.

Gan, Y., Liang, C., Hamel, C., Cutforth, H. and Wang, H., 2011. Strategies for reducing the carbon footprint of field crops for semiarid areas. A review. *Agronomy for Sustainable Development* 31, 643–656.

Gao, L., Mazza, G., 1995. Characterization, quantitation, and distribution of anthocyanins and colorless phenolics in sweet cherries. *Journal of Agricultural and Food Chemistry* 43 (2), 343–346.

Garcia-Montiel, F., Serrano, M., Martinez-Romero, D., Albuquerque, N., 2010. Factors influencing fruit set and quality in different sweet cherry cultivars. *Spanish Journal of Agricultural Research* 8 (4), 1118–1128.

Girard, B., Kopp, T.G., 1998. Physicochemical characteristics of selected sweet cherry cultivars. *Journal of Agricultural and Food Chemistry* 46, 471–476.

Goliáš, J., Létal, J., Veselý, O., 2012. Effect of low oxygen and high carbon dioxide atmospheres on the formation of volatiles during storage of two sweet cherry cultivars. *Horticultural Science* 39, 172–180.

Gonçalves, B., Landbo, A.-., Knudsen, D., Silva, A.P., Moutinho-Pereira, J., Rosa, E. and Meyer, A.S., 2004. Effect of Ripeness and Postharvest Storage on the Phenolic Profiles of Cherries (*Prunus avium* L.). *Journal of Agricultural and Food Chemistry*, 52, 3, 523-530.

Gonçalves, B., Moutinho-Pereira, J., Santos, A., Silva, A.P., Bacelar, E., Correia, C., Rosa, E., 2006. Scionrootstock interaction affects the physiology and fruit quality of sweet cherry. *Tree Physiology* 26, 93–104.

Gonçalves, B., Silva, A.P., Moutinho-Pereira, J., Bacelar, E., Rosa, E., Meyer, A.S., 2007. Effect of ripeness and postharvest storage on the evolution of colour and anthocyanins in cherries (*Prunus avium* L.). *Food Chemistry* 103 (3), 976–984.

González-Gómez, D., Lozano, M., Fernández-León, M.F., Ayuso, M.C., Bernalte, M.J., Rodríguez, A.B., 2009. Detection and quantification of melatonin and serotonin in eight sweet cherry cultivars (*Prunus avium* L.). *European Food Research and Technology* 229, 223–229.

González-Gómez, D., Lozano, M., Fernández-León, M.F., Bernalte, M.J., Ayuso, M.C., Rodríguez, A.B., 2010. Sweet cherry phytochemicals: identification and characterization by HPLC-DAD/ESI-MS in six sweet-cherry cultivars grown in Valle del Jerte (Spain). *Journal of Food Composition and Analysis* 23 (6), 533–539.

Grigoras, C.G., Destandau, E., Zubrzycki, S. and Elfakir, C., 2012. Sweet cherries anthocyanins: An environmental friendly extraction and purification method. *Separation and Purification Technology*, 100, 51-58.

Guglielmi, M., Palasciano, M., Guglielmi, A., Cassanelli, N., 2014. La cerasicoltura nel territorio di Bisceglie, European Territorial Cooperation Programme Greece-Italy 2007-2013. Centro Studi Biscegliese, Bisceglie (BAT) Italy, p. 162.

Gündoğdu, M., Bilge, U., 2012. Determination of organics, phenolics, sugars, and vitamin C contents of some cherry cultivars (*Prunus avium*). *International Journal of Agriculture and Biology* 14, 595–599.

He, F.J. and MacGregor, G.A. 2003. Potassium: More beneficial effects. *Climacteric*. 6, S3, 36–48.

Hedhly, A., Hormaza, J.I., Herrero, M., 2007. Warm temperatures at bloom reduce fruit set in sweet cherry. *Journal of Applied Botany and Food Quality* 81, 158–164.

- Hedrick, U.P., 1915. The Cherries of New York. J. B. Lyon, Albany.
- Hrotko, K., 2008. Progress in cherry rootstock research. *Acta Horticulturae* 795, 171–178.
- Iezzoni, A., Schmidt, H., Albertini, A., 1990. Cherries (*Prunus* spp.). In: Moore, J.N., Ballington, J.R. (Eds.), Genetic Resources of Temperate Fruit and Nut Crops. Intl. Soc. Hort. Sci., Wageningen, The Netherlands. pp. 110–173.
- Ingrao, C., Lo Giudice, A., Tricase, C., Rana, R., Mbohwa, C. and Siracusa, V., 2014. Recycled-PET fibre based panels for building thermal insulation: Environmental impact and improvement potential assessment for a greener production. *Science of the Total Environment*, 493, 914-929.
- Ingrao, C., Matarazzo, A., Tricase, C., Clasadonte, M.T., Huisingsh, D., 2015. Life Cycle Assessment for highlighting environmental hotspots in Sicilian peach production systems. *J. Clean. Prod.* 92, 109-120.
- INSA (The National Health Institute Doutor Ricardo Jorge), 2014. Table of Food Composition (TCA). Available on: <http://www.insa.pt/sites/INSA/Portugues/AreasCientificas/AlimentNutricao/AplicacoesOnline/TabelaAlimentos/Paginas/TabelaAlimentos.aspx>.
- International Organization for Standardization (ISO), 1999, Environmental labels and declarations — Type I environmental labelling — Principles and procedures ISO 14024:1999.
- International Organization for Standardization (ISO), 2000, Environmental labels and declarations — General principles ISO 14020:2000.
- International Organization for Standardization (ISO), 2006, Environmental labels and declarations — Type III environmental declarations — Principles and procedures, ISO 14025:2006.
- International Organization for Standardization (ISO), 2006a. Environmental Management - Life Cycle Assessment - Principles and Framework ISO 14040.
- International Organization for Standardization (ISO), 2006b. Environmental Management - Life Cycle Assessment - Requirements and Guidelines ISO 14044.
- International Organization for Standardization (ISO), 2013. Greenhouse gases - Carbon footprint of products - Requirements and guidelines for quantification and communication ISO 14067:2013.

IPCC, 2007. *Climate Change 2007: Synthesis Report. Contribution of Working Groups I, II and III to the Fourth Assessment Report of the Intergovernmental Panel on Climate Change*, Core Writing Team, R.K. Pachauri, and A. Reisinger, eds. (Geneva, Switzerland: IPCC).

ISPRA, 2016. *Italian Greenhouse Gas Inventory 1990-2014. National Inventory Report n. 239/2016 of Istituto Superiore per la Protezione e la Ricerca Ambientale (Institute for Environmental Protection and Research). Annual Report for submission under the UN Framework Convention on Climate Change and the Kyoto Protocol*.

Jackson, D.I., 1986. *Temperate and Subtropical Fruit Production*. Butterworth of New Zealand, 249.

Jacob, R.A., Spinozzi, G.M., Simon, V.A., Kelley, D.S., Prior, R.L., Hess-Piercet, B. and Kadert, A.A., 2003. Consumption of cherries lowers plasma urate in healthy women. *Journal of Nutrition*, 133, 6, 1826-1829.

Jakobek, L., Šeruga, M., Medvidović-Kosanović, M. and Novak, I., 2007. Anthocyanin content and antioxidant activity of various red fruit juices. *Deutsche Lebensmittel-Rundschau*, 103, 2, 58-64.

Jänes, H., Ardel, P., Kahu, K., Kelt, K., Kikas, A., 2010. Some biological properties and fruit quality parameters of new sweet cherry cultivars and perspective selections. *Agronomy Research* 8 (Special Issue III), 583–588.

Janick, J., 2011. Origin and dissemination of *Prunus* crops: peach, cherry, apricot, plum and almond. *Scripta Horticulturae*, 11.

Jiménez, S., Garín, A., Albás, E.S., Betrán, J.A., Gogorcena, Y., Moreno, M.A., 2004. Effect of several rootstocks on fruit quality of ‘Sunburst’ sweet cherry. *Acta Horticulturae* 658, 353–358.

Johnston, J.L., Fanzo, J.C. and Cogill, B., 2014. Understanding sustainable diets: A descriptive analysis of the determinants and processes that influence diets and their impact on health, food security, and environmental sustainability. *Advances in Nutrition*. 5, 4, 418-429.

Kang, S.Y., Seeram, N.P., Nair, M.G. and Bourquin, L.D., 2003. Tart cherry anthocyanins inhibit tumor development in *Apc(Min)* mice and reduce proliferation of human colon cancer cells. *Cancer letters*, 194, 1, 13-19.

Kappel, F. 2005. New sweet cherry cultivars from the Pacific Agr-Food Research Centre (Summerland). *Acta Horticulturae*, 667, 53–57.

Kappel, F. and Lane, W.D., 1998. Recent sweet cherry introductions from the breeding program at Summerland, British Columbia, Canada. *Acta Horticulturae*, 468, 105–109.

Kappel, F., Granger, A., Hrotkó, K. and Schuster, M., 2012. Cherry. In: Badenes, M.L. and Byrne, D.H. (eds) *Fruit Breeding, Handbook of Plant and Breeding*. Springer Science + Business Media, New York, 459–504.

Kappel, F., Lane, W.D., MacDonald, R., Lapins, K., and Schmid, H. 2000a. ‘Sumste Samba’, ‘Sandra Rose’, and ‘Sumleta Sonata’ sweet cherries. *Acta Horticulturae*, 35:152–154.

Kappel, F., Lane, W.D., MacDonald, R.A., and Schmid, H., 2000b. ‘Skeena’ sweet cherry. *HortScience* 35, 306–307.

Keenan, M.J., Zhou, J., McCutcheon, K.L., Raggio, A.M., Bateman, H.G., Todd, E., Jones, C.K., Tulley, R.T., Melton, S., Martin, R.J., and Hegsted, M., 2006. Effects of resistant starch, a non-digestible fermentable fiber, on reducing body fat. *Obesity*, 14, 9, 1523–34.

Kelebek, H., Selli, S., 2011. Evaluation of chemical constituents and antioxidant activity of sweet cherry (*Prunus avium* L.) cultivars. *International Journal of Food Science and Technology* 46, 12, 2530–2537.

Khoo, G.M., Clausen, M.R., Pedersen, B.H., Larsen, E., 2011. Bioactivity and total phenolic content of 34 sour cherry cultivars. *Journal of Food Composition and Analysis* 24 (6), 772–776.

Kim, D.-., Ho, J.H., Young, J.K., Hyun, S.Y. and Lee, C.Y., 2005. Sweet and sour cherry phenolics and their protective effects on neuronal cells. *Journal of Agricultural and Food Chemistry*, 53, 26, 9921-9927.

Kizilaslan, H., 2009. Input-output energy analysis of cherries production in Tokat Province of Turkey. *Applied Energy* 86,7, 1354-1358.

Kore, V.T., Tawade, S.S. and Kabir, J., 2017. Application of Edible Coatings on Fruits and Vegetables. *Imperial Journal of Interdisciplinary Research*. 3, 1: 591-603.

Kroodsma, D.A. and Field, C.B., 2006. Carbon sequestration in California agriculture, 1980–2000. *Ecological Applications*, 16, 1975–1985.

Lane, W.D. and Schmid, H., 1984. Lapins and Sunburst sweet cherry. *Canadian Journal of Plant Science*, 64, 211–214.

Lang, G., Ophardt, D., and Olmstead, J. 1998. Sweet cherry breeding at Washington State University. *Acta Horticulturae*. 468:97–104.

Lang, G.A., 1999. Cherry – Sweet. *HortScience*, 34,186–187.

Lang, G.A., 2002. Cherry – Sweet. *HortScience*, 37, 253–255.

- Lapins, K.O., 1974. Summit sweet cherry. *Canadian Journal of Plant Science*, 54:851.
- Levaj, B., Dragović-Uzelac, V., Delonga, K., Ganić, K.K., Banović, M., Kovačević, D.B., 2010. Polyphenols and volatiles in fruits of two sour cherry cultivars, some berry fruits and their jams. *Food Technology and Biotechnology* 48 (4), 538–547.
- Litskas, V.D., Mamolos, A.P., Kalburtji, K.L., Tsatsarelis, C.A., Kiose-Kampasakali, E., 2011. Energy flow and greenhouse gas emissions in organic and conventional sweet cherry orchards located in or close to Natura 2000 sites. *Biomass Bioenergy* 35, 3, 1302-1310.
- Liu Y., Liu X., Zhong F., Tian R., Zhang K., Zhang X., 2011. Comparative study of phenolic compounds and antioxidant activity in different species of cherries. *Journal of Food Science*, 76, 633–638.
- Liu, T., Wang, Q. and Su, B., 2016. A review of carbon labeling: Standards, implementation, and impact. *Renewable and Sustainable Energy Reviews*, 53, 68-79.
- Lugli, S., Musacchi, S., 2009. L'alta densità nel ciliegio assicura produzioni e qualità. *L'Informatore Agrar.* 46, 37-40.
- Mahfoudhi, N. and Hamdi, S., 2015. Use of almond gum and gum arabic as novel edible coating to delay postharvest ripening and to maintain sweet cherry (*Prunus avium*) quality during storage. *Journal of Food Processing and Preservation.* 39, 6:1499-1508.
- Mahfoudhi, N., Chouaibi, C. and Hamdi, S. 2014. Effectiveness of almond gum trees exudate as a novel edible coating for improving postharvest quality of tomato (*Solanum lycopersicum* L.) fruits. *Food Science and Technology International.* 20, 1: 33–43.
- Mamani-Matsuda, M., Kauss, T., Al-Kharrat, A., Rambert, J., Fawaz, F., Thiolat, D., Moynet, D., Coves, S., Malvy, D. and Mossalayi, M.D., 2006. Therapeutic and preventive properties of quercetin in experimental arthritis correlate with decreased macrophage inflammatory mediators. *Biochemical pharmacology*, 72, 10, 1304-1310.
- Martinez-Romero, D., Albuquerque, N., Valverde, J.M., Guill'En, F., Castillo, S., Valero, D., Serrano, M., 2006. Postharvest sweet cherry quality and safety maintenance by Aloe Vera treatment: A new edible coating. *Postharvest Biology and Technology.* 39, 1: 93–100.
- Mattheis, J.P., Buchanan, D.A., Fellman, J.K., 1992. Volatile compounds emitted by sweet cherries (*Prunus avium* Cv. Bing) during fruit development and ripening. *Journal Agricultural and Food Chemistry* 40, 471–474.

Mattheis, J.P., Buchanan, D.A., Fellman, J.K., 1997. Volatile constituents of Bing sweet cherry fruit following controlled atmosphere storage. *Journal Agricultural and Food Chemistry* 45, 212–216.

McCune, L. M., Kubota, C., Stendell-Hollis, N. R., and Thomson, C. A., 2011. Cherries and health: A review. *Critical Reviews in Food Science and Nutrition*, 51, 1–12.

McLellan, M.R., Padilla-Zakour, O.I., 2004. Sweet cherry and sour cherry processing, in book: *Processing Fruits: Science and Technology*, Barrett, D.M., Laszlo Somogyi, Ramaswamy, H. S., Second Edition, CRC, 497-509.

Mellinas, C., Valdés, A., Ramos, M., Burgos, N., Del Carmen Garrigós, M. and Jiménez, A., 2016. Active edible films: Current state and future trends. *Journal of Applied Polymer Science*. 133.

Milà I Canals, L., Burnip, G.M. & Cowell, S.J., 2006. Evaluation of the environmental impacts of apple production using Life Cycle Assessment (LCA): Case study in New Zealand. *Agriculture, Ecosystems and Environment*, 114, 2-4, 226-238.

Milošević, T., Milošević, N., 2012. Fruit quality attributes of sour cherry cultivars. *International Scholarly Research Notices, Agronomy* 2012, 1–5.

Montanaro, G., Tuzio, A.C., Xylogiannis, E., Kolimenakis, A. and Dichio, B., 2017. Carbon budget in a Mediterranean peach orchard under different management practices. *Agriculture, Ecosystems and Environment*, 238, 104-113.

Mozetič, B., Simčič, M., Trebše, P., 2006. Anthocyanins and hydroxycinnamic acids of Lambert Compact cherries (*Prunus avium* L.) after cold storage and 1-methylcyclopropene treatment. *Food Chemistry* 97 (2), 302–309.

Mozetič, B., Trebše, P., Hribar, J., 2002. Determination and quantitation of anthocyanins and hydroxycinnamic acids in different cultivars of sweet cherries (*Prunus avium* L.) from Nova Gorica Region (Slovenia). *Food Technology and Biotechnology* 40, 3, 207–212.

Najm, A.A., Hadi, M.R.H.S., Fazeli, F., Darzi, M.T. and Rahi, A., 2012. Effect of Integrated Management of Nitrogen Fertilizer and Cattle Manure on the Leaf Chlorophyll, Yield, and Tuber Glycoalkaloids of Agria Potato. *Communications in Soil Science and Plant Analysis*, 43, 6, 912-923.

OECD, 2001. *Environmental indicators for agriculture, Vol. 3. Methods and results*, vol OECD (Organization for Economic Cooperation and Development). France, Paris.

Organisation for Economic Cooperation and Development (OECD), 2015. International Standards for Fruit and Vegetables. Cherries.

PAS 2050:2008 Specification for the Assessment of the Life Cycle Greenhouse Gas Emissions of Goods and Services British Standards Institution, London.

PAS 2050:2011 Specification for the Assessment of the Life Cycle Greenhouse Gas Emissions of Goods and Services British Standards Institution, London.

Pascall, M.A. and Lin S.J., 2013. The application of edible polymeric films and coatings in the food industry. *Journal Food Processing & Technology*. 4, 116.

Pergola, M., D'Amico, M.b, Celano, G., Palese, A.M.A, Scuderi, A., Di Vita, G., Pappalardo, G., Inglese, P., 2013. Sustainability evaluation of Sicily's lemon and orange production: an energy, economic and environmental analysis. *J. Environ. Manag.* 128, 674-682.

Quero Garcia, José & Schuster, Mirko & Ortega, Gregorio & Charlot, G. 2017. Sweet Cherry Varieties and Improvement. In book: *Cherries: Botany, Production and Uses*, Chapter: 4, Publisher: CABI, Editors 60-94.

Rojas-Graü, M.A., Soliva-Fortuny, R., Martin-Belloso, O., 2011. Use of edible coatings for fresh-cut fruits and vegetables in advances in fresh-cut fruits and vegetables processing. Taylor & Francis, 211-229.

Sansavini, S. and Lugli, S., 2008. Sweet cherry breeding programmes in Europe and Asia. *Acta Horticulturae* 795, 41–58.

Sansavini, S., and Lugli, S. 2005. New sweet cherry cultivars developed at the University of Bologna. *Acta Horticulturae*, 667, 45–52.

Schau, E.M. and Fet, A.M., 2008. LCA studies of food products as background for environmental product declarations. *International Journal of Life Cycle Assessment*, 13, 3, 255-264.

Scoma, A., Pintucci, C., Bertin, L., Carlozzi, P. and Fava, F., 2012. Increasing the large scale feasibility of a solid phase extraction procedure for the recovery of natural antioxidants from olive mill wastewaters. *Chemical Engineering Journal*, 103-109.

Seeram, N.P., Momin, R.A., Nair, M.G. and Bourquin, L.D., 2001. Cyclooxygenase inhibitory and antioxidant cyanidin glycosides in cherries and berries. *Phytomedicine*, 8, 5, 362-369.

Serra, A. T., Duarte, R. O., Bronze, M. R., and Duarte, C. M. M., 2011a. Identification of bioactive response in traditional cherries from Portugal. *Food Chemistry*, 125, 318–325.



Serra, A. T., Matias, A. A., Almeida, A. P. C., Bronze, M. R., Alves, P. M., De Sousa, H. C., Duarte, C.M.M., 2011b. Processing cherries (*Prunus avium*) using supercritical fluid technology. Part 2. Evaluation of SCF extracts as promising natural chemotherapeutical agents. *Journal of Supercritical Fluids*, 55, 1007–1013.

Serra, A.T., Seabra, I.J., Braga, M.E.M., Bronze, M.R., De Sousa, H.C. and Duarte, C.M.M., 2010. Processing cherries (*Prunus avium*) using supercritical fluid technology. Part 1: Recovery of extract fractions rich in bioactive compounds. *Journal of Supercritical Fluids*, 55, 1, 184-191.

Serradilla, M. J., A. Hernández, M. López-Corrales, S. Ruiz-Moyano, M. de Guía Córdoba, and A. Martín. 2015. Composition of the Cherry (*Prunus Avium* L. and *Prunus Cerasus* L.; Rosaceae). In *Nutritional Composition of Fruit Cultivars*, 127-147.

Serrano M., Díaz-Mula H.M., Zapata P.J., Castillo S., Guillen F., Martínez-Romero D., et al. 2009. Maturity stage at harvest determines the fruit quality and antioxidant potential after storage of sweet cherry cultivars *Journal of Agricultural and Food Chemistry*, 57, pp. 3240 – 3246.

Sharp, A. and Wheeler, M., 2013. Reducing householders' grocery carbon emissions: Carbon literacy and carbon label preferences. *Australasian Marketing Journal*, 21, 4, 240-249.

Shepherd, M., Pearce, B., Cormack, B., Philipps, L., Cuttle, S., Bhogal, A., Costigan, P., and Unwin R., 2003. An assessment of the environmental impacts of organic farming. A review for DEFRA-funded Project OF0405, London, UK.

Shi, X., 2010. Carbon footprint labeling activities in the East Asia summit region: spillover effects to less developed countries (No. DP-2010-06). Economic Research Institute for ASEAN and East Asia (ERIA).

SimaPro, 2006. LCA Software and Database Manual. Pre-Consultants BV, Amersfoort, The Netherlands.

Smith, P., Martino, D., Cai, Z., Gwary, D., Janzen, H.H., Kumar, P., McCarl, B., Ogle, S., O'Mara, F., and Rice, C., 2007. Policy and technological constraints to implementation of greenhouse gas mitigation options in agriculture. *Agriculture, Ecosystems & Environment*, 118, 6-28.

Stéger-Maté, M. 2012. Sweet and Tart Cherries. In *Handbook of Fruits and Fruit Processing: Second Edition*, 433-446.

Stolze, M., Piorr, A., Häring, A. and Dabbert, S., 2000. Environmental impacts of organic farming in Europe. *Organic farming in Europe: economics and policy*. University of Hohenheim, Stuttgart.

Suter, P.M., 2005. Carbohydrates and dietary fiber. *Handbook of Experimental Pharmacology*, 170, 231–261.

Tian, S., Jiang, A., Xu, Y. and Wang, Y., 2004. Responses of physiology and quality of sweet cherry fruit to different atmospheres in storage. *Food Chemistry*, 87, 1, 43-49.

Tricase, C., Rana, R., Andriano, A.M. and Ingraio, C., 2017. An input flow analysis for improved environmental sustainability and management of cherry orchards: A case study in the Apulia region. *Journal of Cleaner Production*. 156, 766-774.

United Nations Commodity Trade Statistics Database (UNCTSD) - Statistics Division, 2016. Commodity Code: 080920 “Cherries Fresh”. Available on. <http://comtrade.un.org/data/> (Accessed 07 December 2016).

United Nations Economic Commission for Europe (UNECE), 2017. UNECE STANDARD FFV-13 concerning the marketing and commercial quality control of cherries. 2017 edition.

USDA, United States Department of Agriculture, 2015. Stone Fruit Annual, GAIN Report NR. SP1525. Available on. [http://gain.fas.usda.gov/Recent%20GAIN%20Publications/Stone%20Fruit%20Annual\\_Madrid\\_EU-28\\_8-21-2015.pdf](http://gain.fas.usda.gov/Recent%20GAIN%20Publications/Stone%20Fruit%20Annual_Madrid_EU-28_8-21-2015.pdf) (Accessed 18 April 2016).

USDA, United States Department of Agriculture, 2016. National Nutrient Database for Standard Reference. Available on <https://ndb.nal.usda.gov/ndb/foods/show/2183?n1=%7BQv%3D1%7D&fgcd=&sort=&offset=&format=Stats&new=&measureby=&ds=&qt=&qp=&qa=&qn=&q=&ing=> (Accessed 20 November 2017).

USDA, United States Department of Agriculture, 2017. Natural Resources Conservation Service. Available on <https://plants.usda.gov/core/profile?symbol=PRAV> (Accessed 20 November 2017).

Usenik V., Fajt N., Mikulic-Petkovsek M., Slatnar A., Stampar F., Veberic R., 2010. Sweet cherry pomological and biochemical characteristics influenced by rootstock *Journal of Agricultural and Food Chemistry*, 58, pp. 4928–4933.

Usenik, V., Fabčič, J. and Štampar, F., 2008. Sugars, organic acids, phenolic composition and antioxidant activity of sweet cherry (*Prunus avium* L.). *Food Chemistry*, 107, 1, 185-192.

- Usenik, V., Kastelec, D. and Štampar, F., 2005. Physicochemical changes of sweet cherry fruits related to application of gibberellic acid. *Food Chemistry*, 90, 4, 663-671.
- Valero D. and Serrano M., 2010. *Postharvest Biology and Technology for Preserving Fruit Quality*. CRC-Taylor & Francis, Boca Raton, USA.
- Valkanov, N., 2015. *Cherry Production in Bulgaria*, Inteliagro American for Bulgaria Foundation. Available on. [http://www.internationaalondernemen.nl/sites/internationaalondernemen.nl/files/marktrapport/C\\_herry\\_Growing\\_in\\_Bulgaria\\_InteliAgro\\_Eng.pdf](http://www.internationaalondernemen.nl/sites/internationaalondernemen.nl/files/marktrapport/C_herry_Growing_in_Bulgaria_InteliAgro_Eng.pdf) (Accessed 07 December 2016).
- Vargas, M., Pastor, C., Chiralt, A., McClements, D.J. and González-Martínez, C., 2008. Recent Advances in Edible Coatings for Fresh and Minimally Processed Fruits. *Critical Reviews in Food Science and Nutrition*. 48, 6: 496-511.
- Vaskonen, T., 2003. Dietary minerals and modification of cardiovascular risk factors. *Journal of Nutritional Biochemistry*, 14, 492–506.
- Vavilov, N.I., 1951. *The Origin, Variation, Immunity and Breeding of Cultivated Plants*. *Chronica botanica*, v. 13, New York, Ronald Press, p 364.
- Vinyes, E., Asin, L., Alegre, S., Gasol, C.M. and Muñoz, P., 2018. Carbon footprint and profitability of two apple cultivation training systems: Central axis and Fruiting wall. *Scientia Horticulturae*, 229, 233-239.
- Vinyes, E., Gasol, C.M., Asin, L., Alegre, S. & Muñoz, P., 2015. Life Cycle Assessment of multiyear peach production. *Journal of Cleaner Production*, 104, 68-79.
- Wani, A.A., Singh, P., Gul, V., Wani, M.H., Langouski, H.C., 2014. Sweet cherry (*Prunus avium*): critical factors affecting the composition and shelf life. *Food Packaging. Shelf life* 1, 1, 86-99.
- Watkins, R., 1976. Cherry, Plum, Peach, Apricot and Almond in Evolution of crop plants. In Simmonds NW, ed., Longman, New York, 242–247.
- Xiloyannis, C., Montanaro, G., Mininni, A.N. and Dichio, B., 2015. Sustainable production systems in fruit tree orchards.
- Yilmaz, K.U., Ercisli, S., Zengin, Y., Sengul, M. and Kafkas, E.Y., 2009. Preliminary characterisation of cornelian cherry (*Cornus mas* L.) genotypes for their physico-chemical properties. *Food Chemistry*, 114, 2, 408-412.

Yoo, K.M., Al-Farsi, M., Lee, H., Yoon, H. and Lee, C.Y., 2010. Antiproliferative effects of cherry juice and wine in Chinese hamster lung fibroblast cells and their phenolic constituents and antioxidant activities. *Food Chemistry*, 123, 3, 734-740.

Zanotelli, D., Montagnani, L., Manca, G. and Tagliavini, M., 2013. Net primary productivity, allocation pattern and carbon use efficiency in an apple orchard assessed by integrating eddy covariance, biometric and continuous soil chamber measurements. *Biogeosciences*, 10, 5, 3089-3108.

Zanotelli, D., Montagnani, L., Manca, G., Scandellari, F. and Tagliavini, M., 2015. Net ecosystem carbon balance of an apple orchard. *European Journal of Agronomy*, 63, 97-104.

.

# APPENDIX

## Carbon Footprint of each treatment and phase in system boundaries

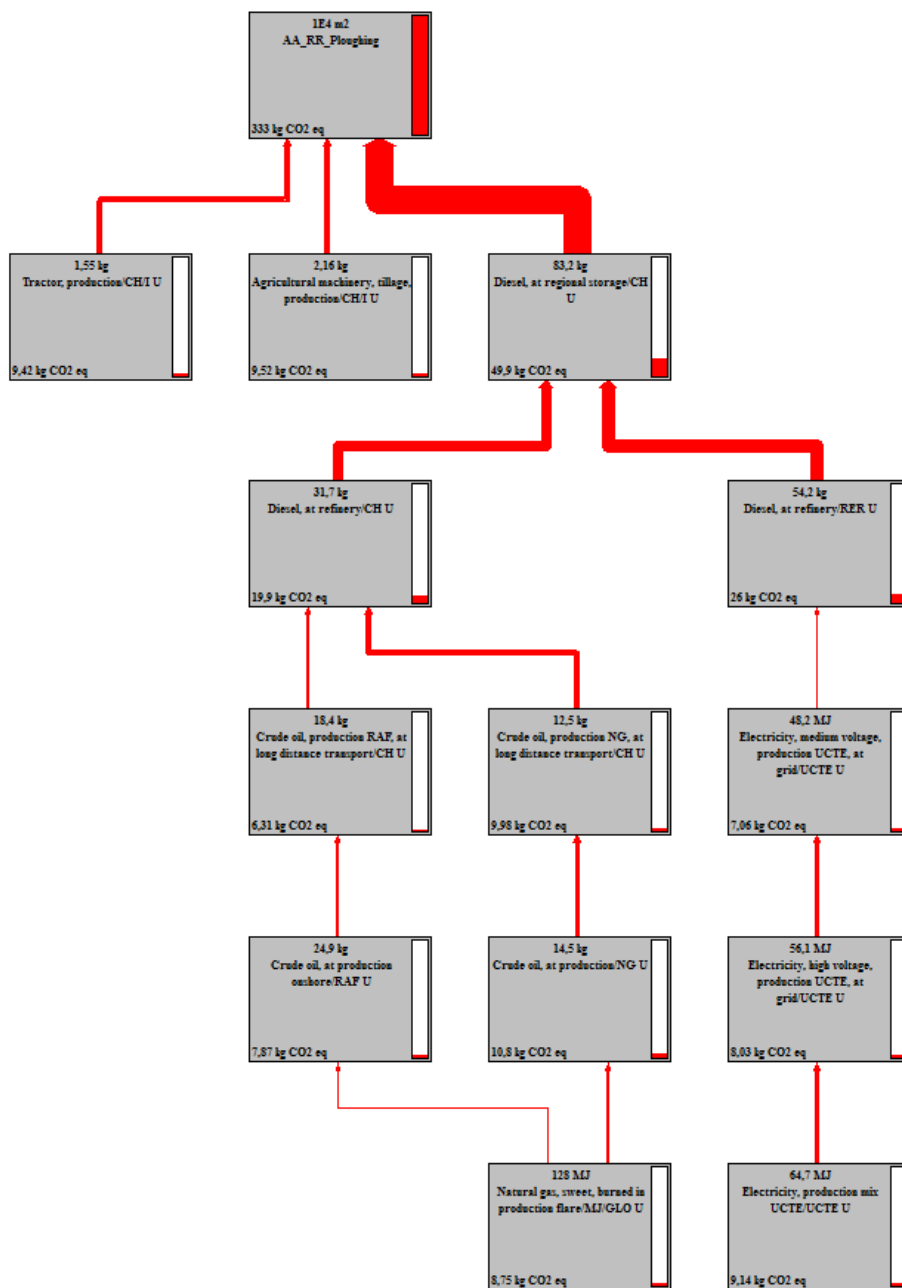

Figure 27: Sankey diagram (kgCO<sub>2</sub>eq) of ploughing- (FU: 1 plant of sweet cherry)

Sustainability and innovation of the sweet cherry supply chain

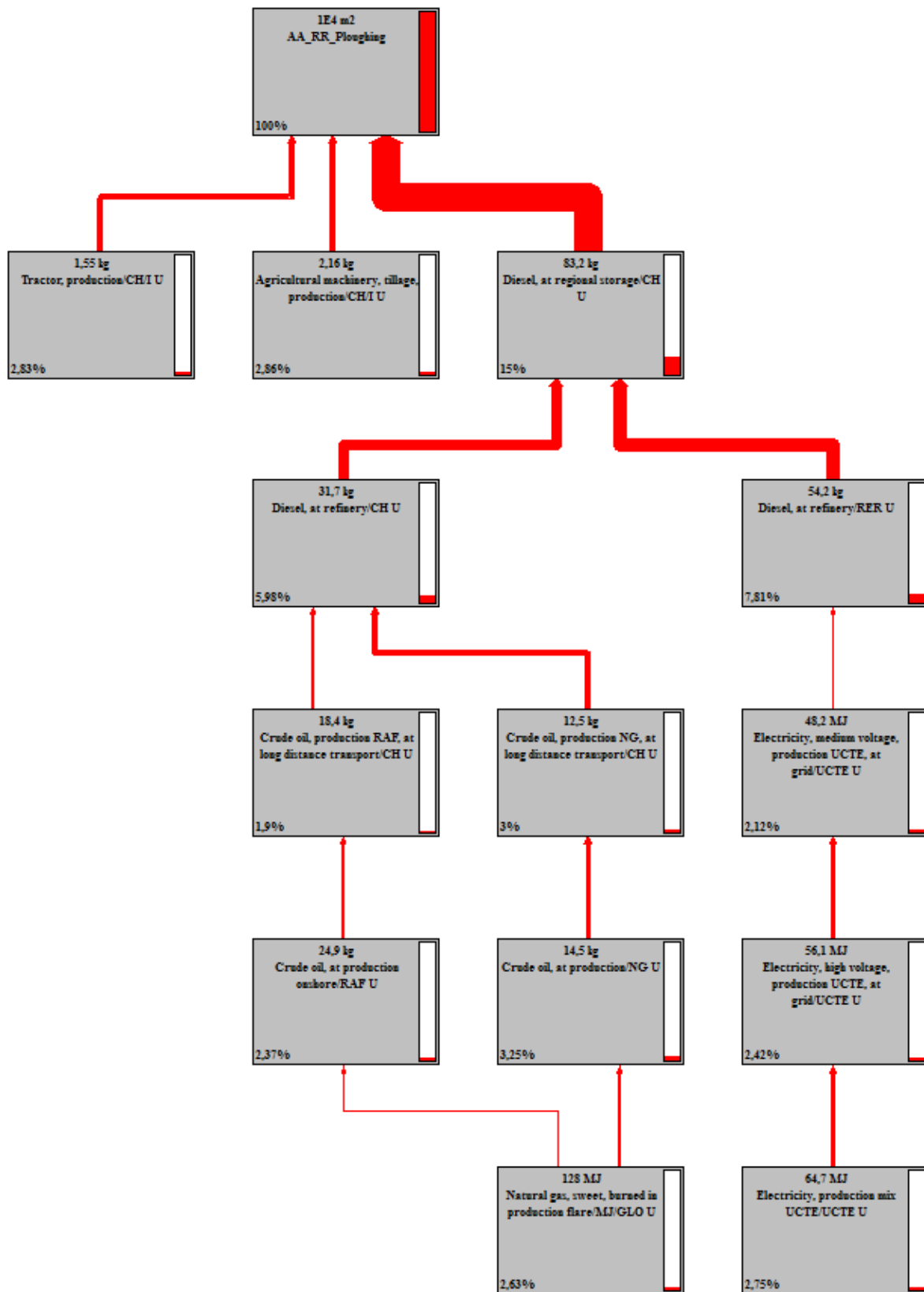

Figure 28: Sankey diagram (%) of ploughing- (FU: 1 plant of sweet cherry)

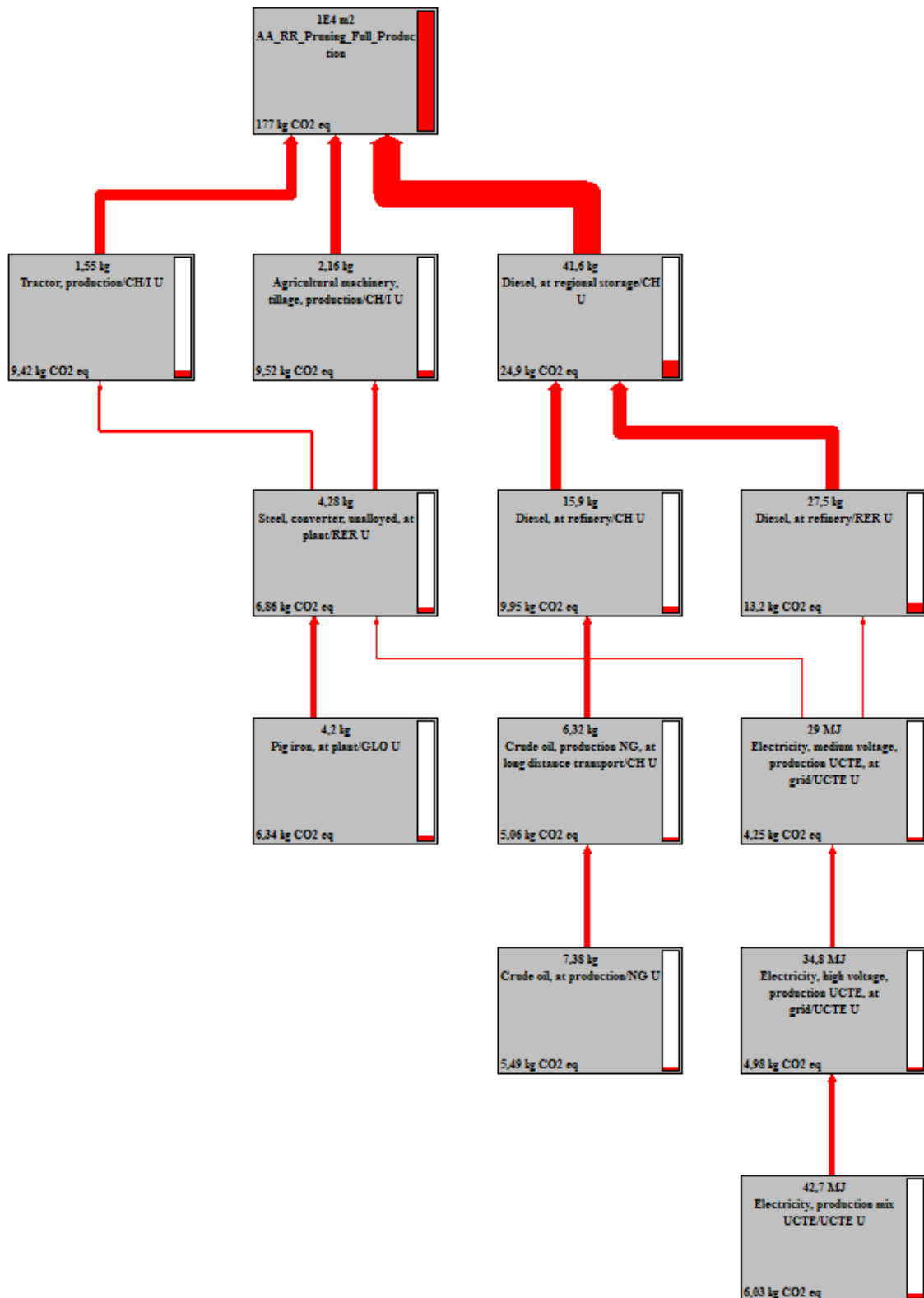

Figure 29: Sankey diagram (kgCO<sub>2</sub>eq) of pruning- (FU: 1 plant of sweet cherry)

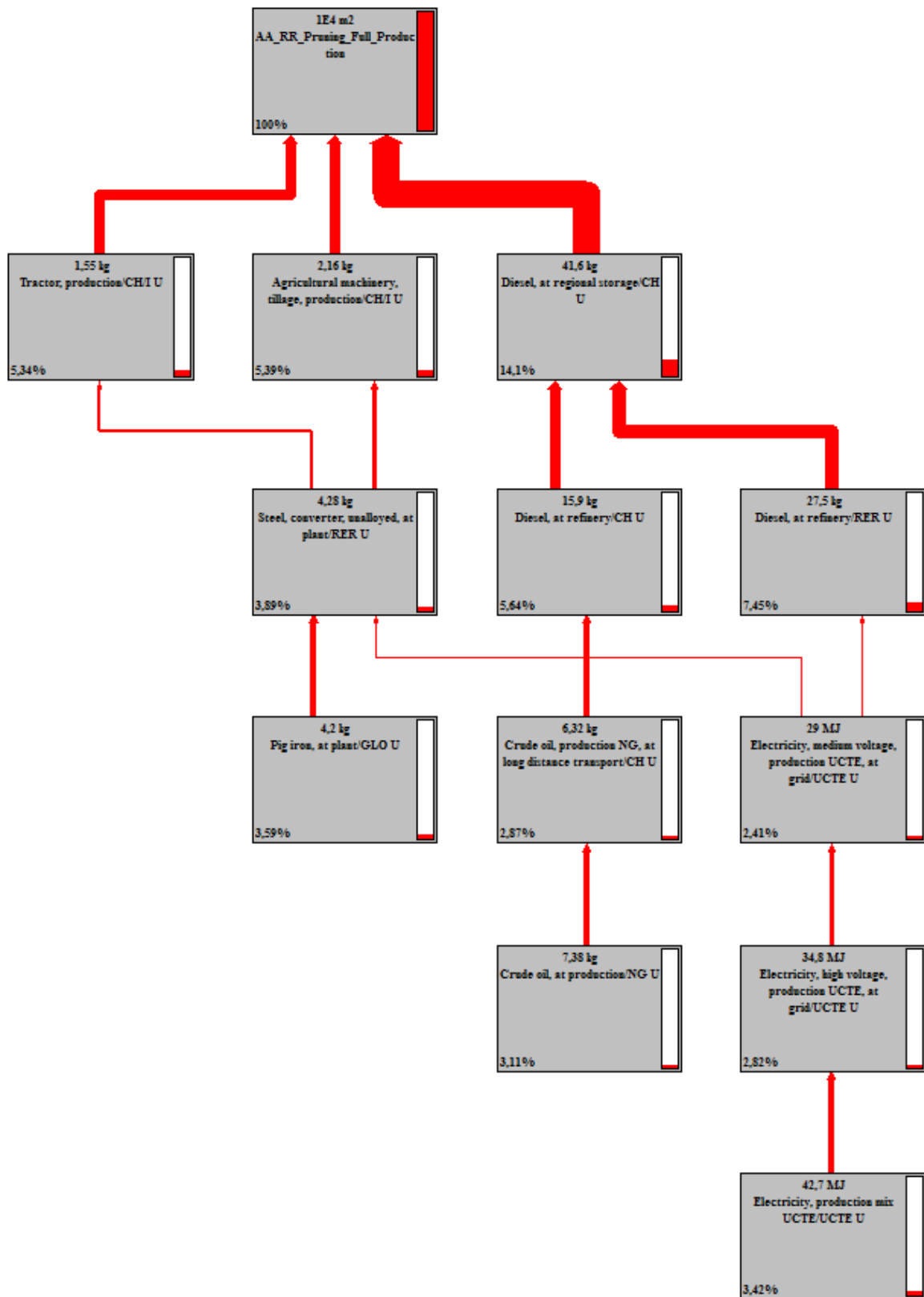

Figure 30: Sankey diagram (%) of pruning- (FU: 1 plant of sweet cherry)



Sustainability and innovation of the sweet cherry supply chain

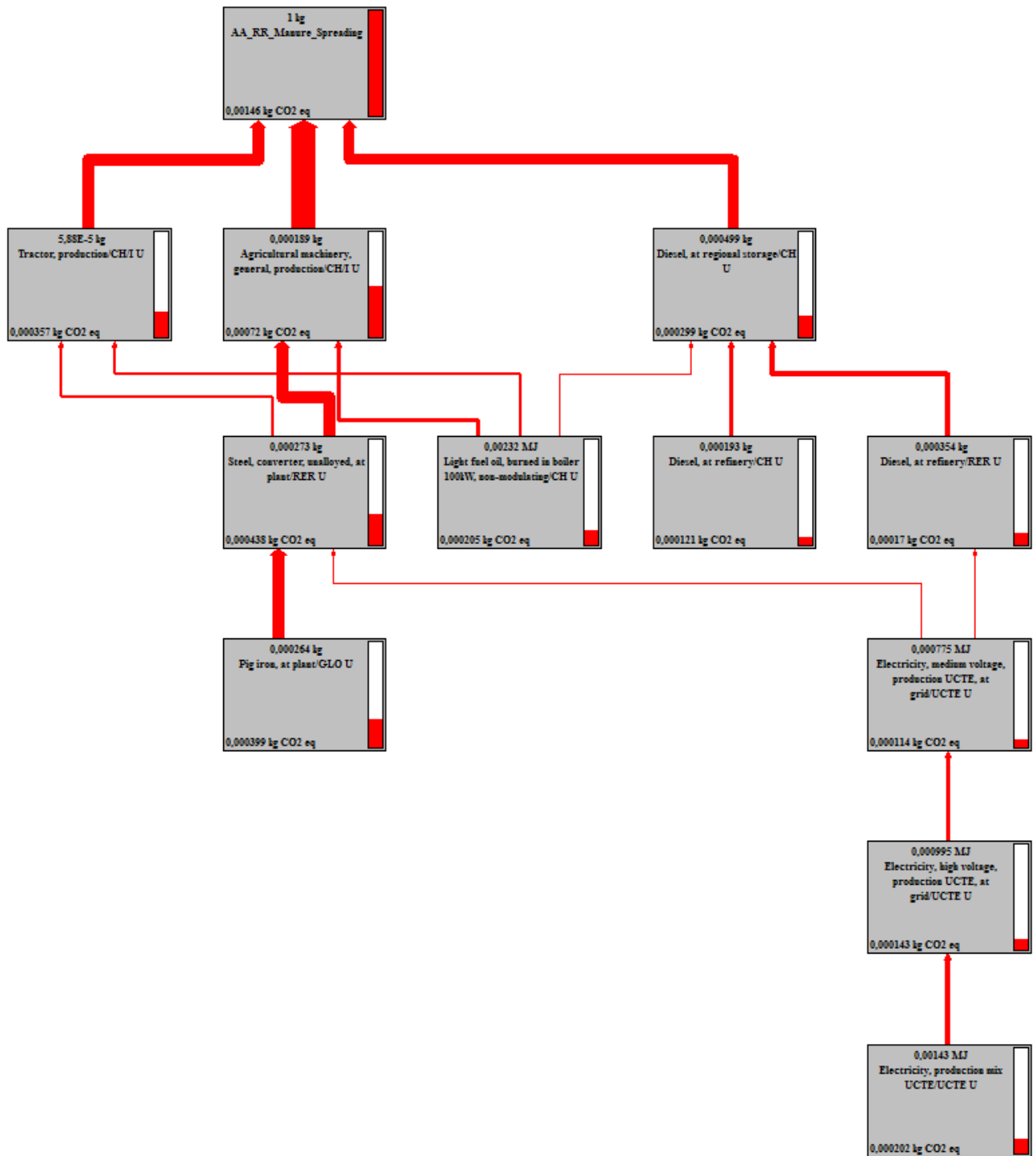

Figure 31: Sankey diagram (kgCO<sub>2</sub>eq) of manure spreading- (FU: 1 plant of sweet cherry)

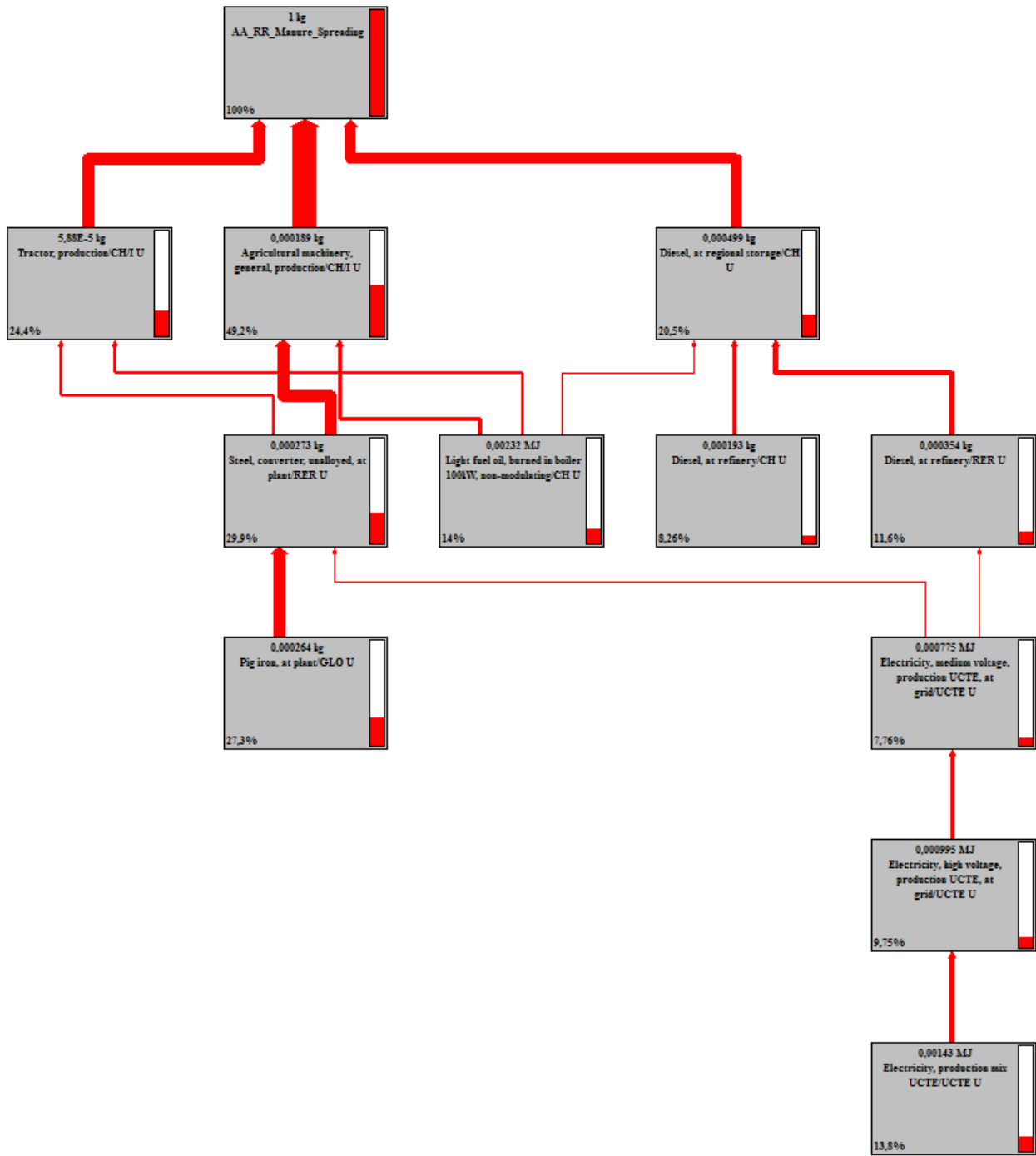

Figure 32: Sankey diagram (%) of manure spreading - (FU: 1 plant of sweet cherry)

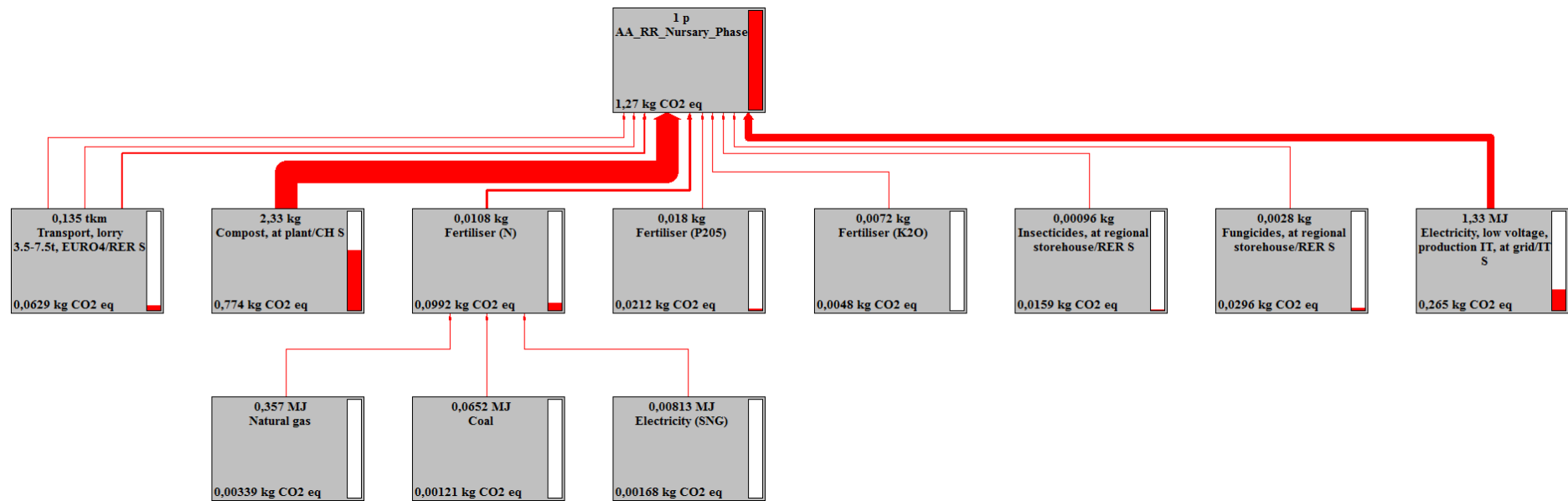

Figure 33: Sankey diagram (kgCO<sub>2</sub>eq) of nursery phase - (FU: 1 plant of sweet cherry)

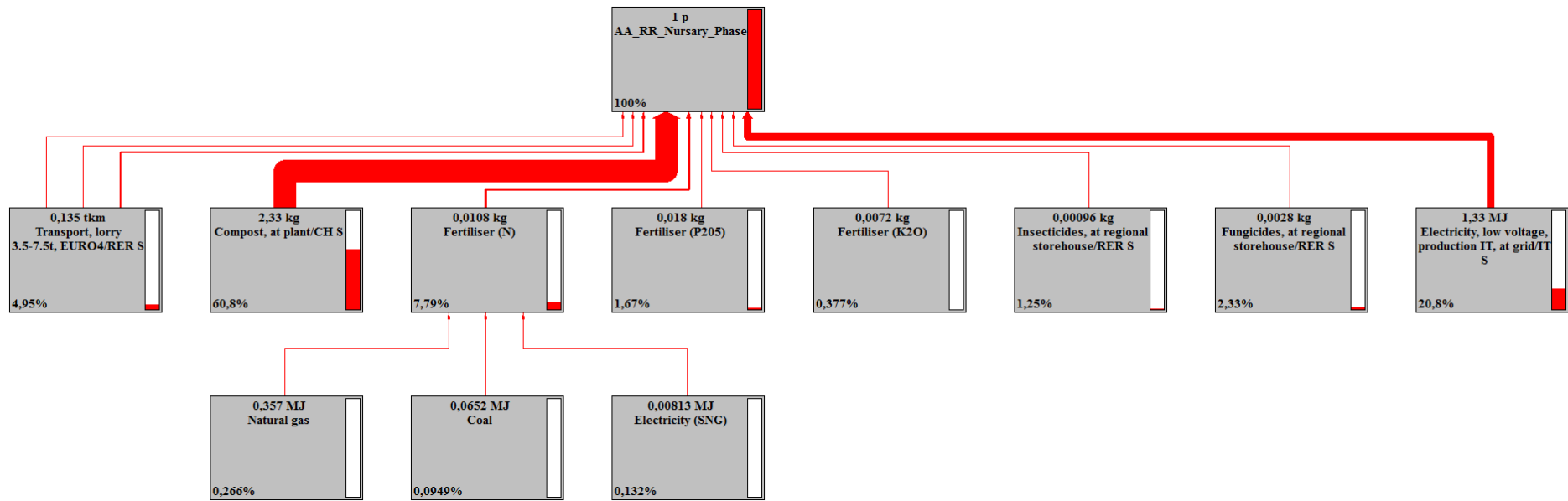
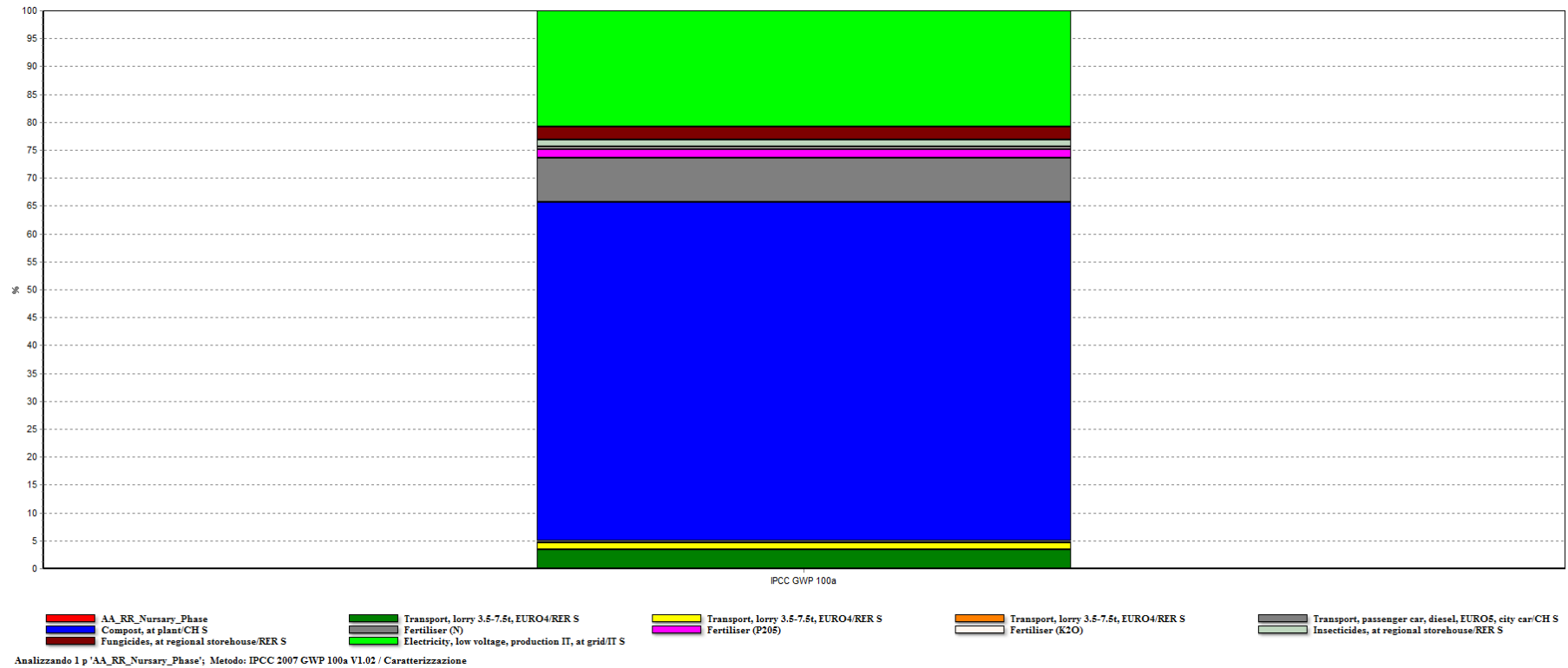

Figure 34: Sankey diagram (%) of nursery phase - (FU: 1 plant of sweet cherry)

## Sustainability and innovation of the sweet cherry supply chain



**Figure 35: Most contribution of GHGs (%) in nursery phase (FU: 1 plant of sweet cherry)**

Sustainability and innovation of the sweet cherry supply chain

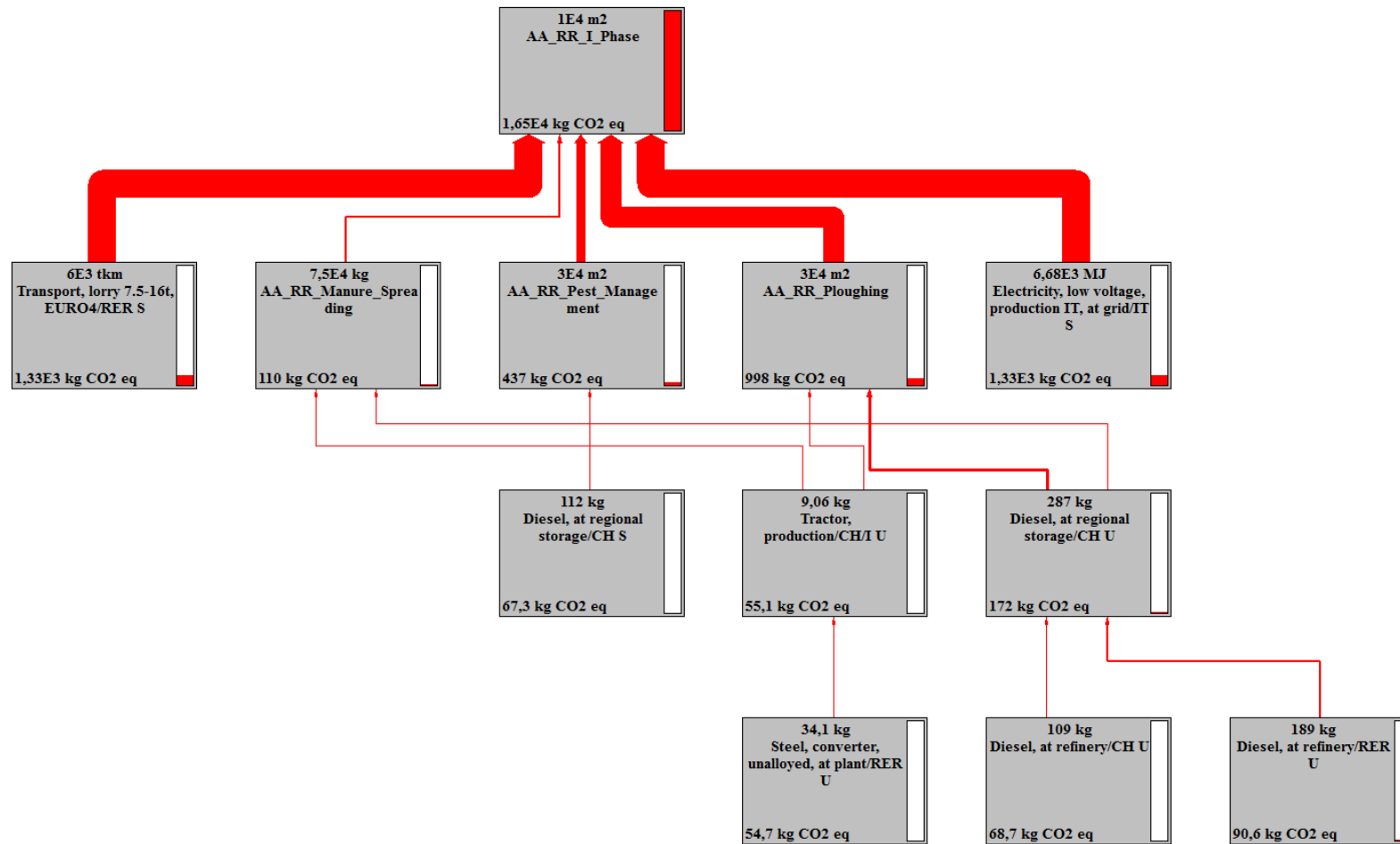

Figure 36: Sankey diagram (kgCO<sub>2eq</sub>) of I Phase - (FU: 1 ha sweet cherry orchard)

Sustainability and innovation of the sweet cherry supply chain

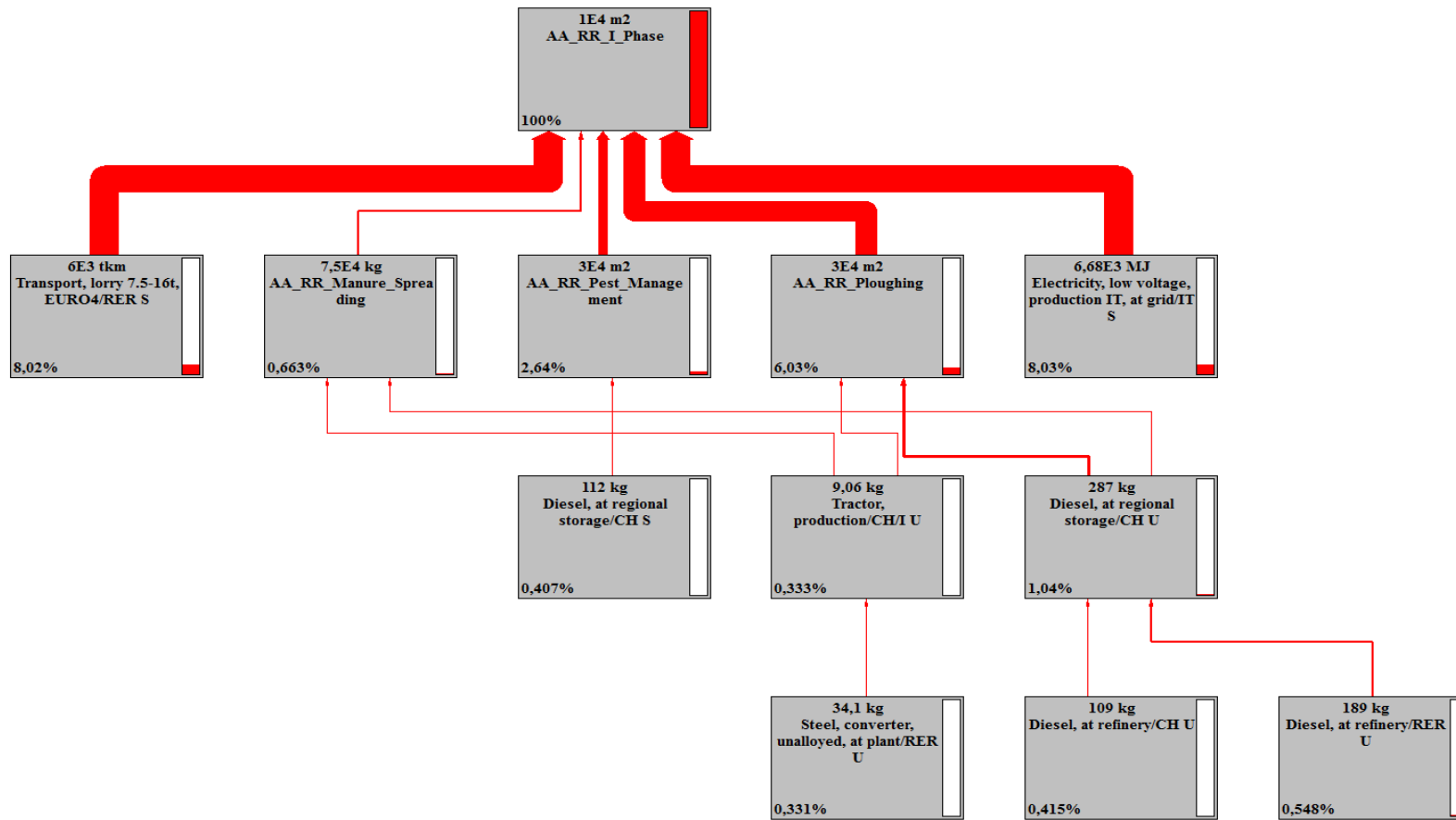
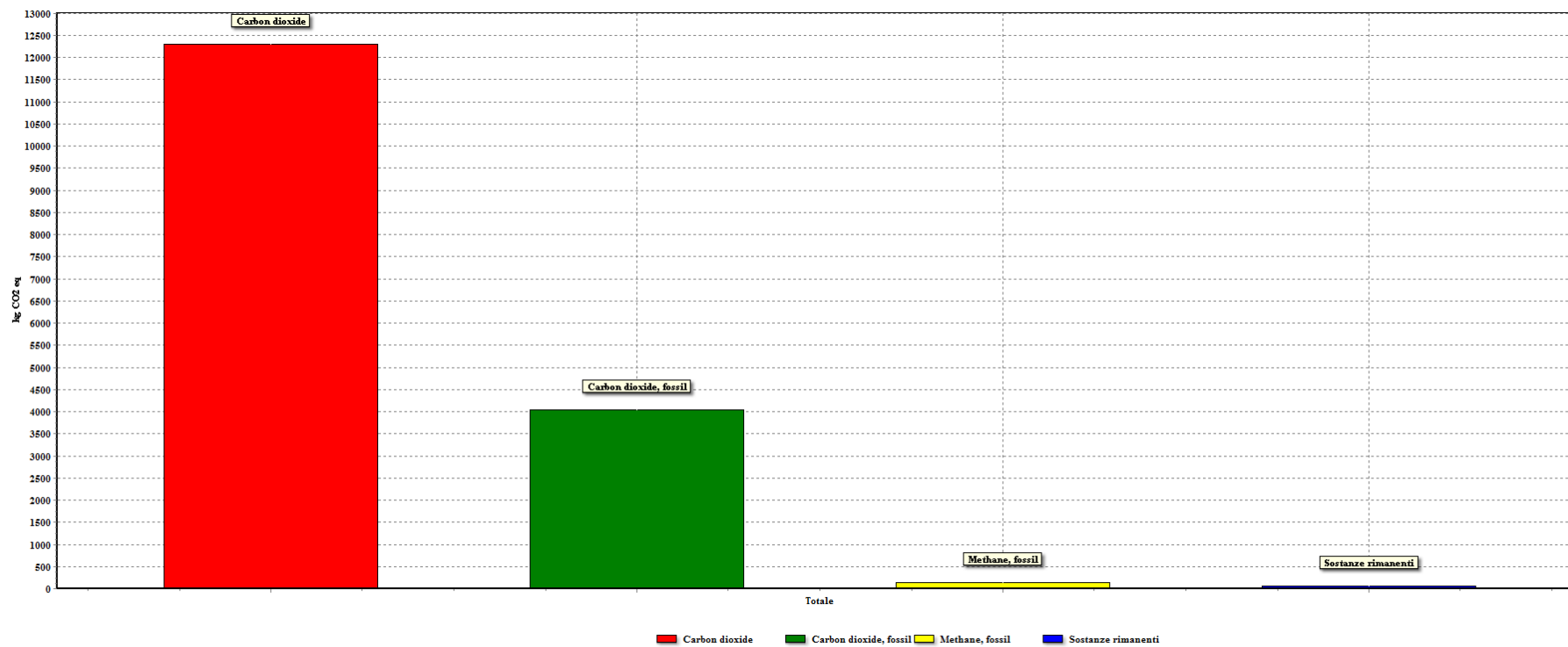

Figure 37: Sankey diagram (%) of I Phase - (FU: 1 ha sweet cherry orchard)

## Sustainability and innovation of the sweet cherry supply chain



Analizzando 1 ha 'AA\_RR\_I\_Phase'; Metodo: IPCC 2007 GWP 100a V1.02 / Caratterizzazione

**Figure 38: Most contribution of GHGs (kgCO<sub>2</sub>eq) in I Phase - (FU: 1 ha sweet cherry orchard)**



## Sustainability and innovation of the sweet cherry supply chain

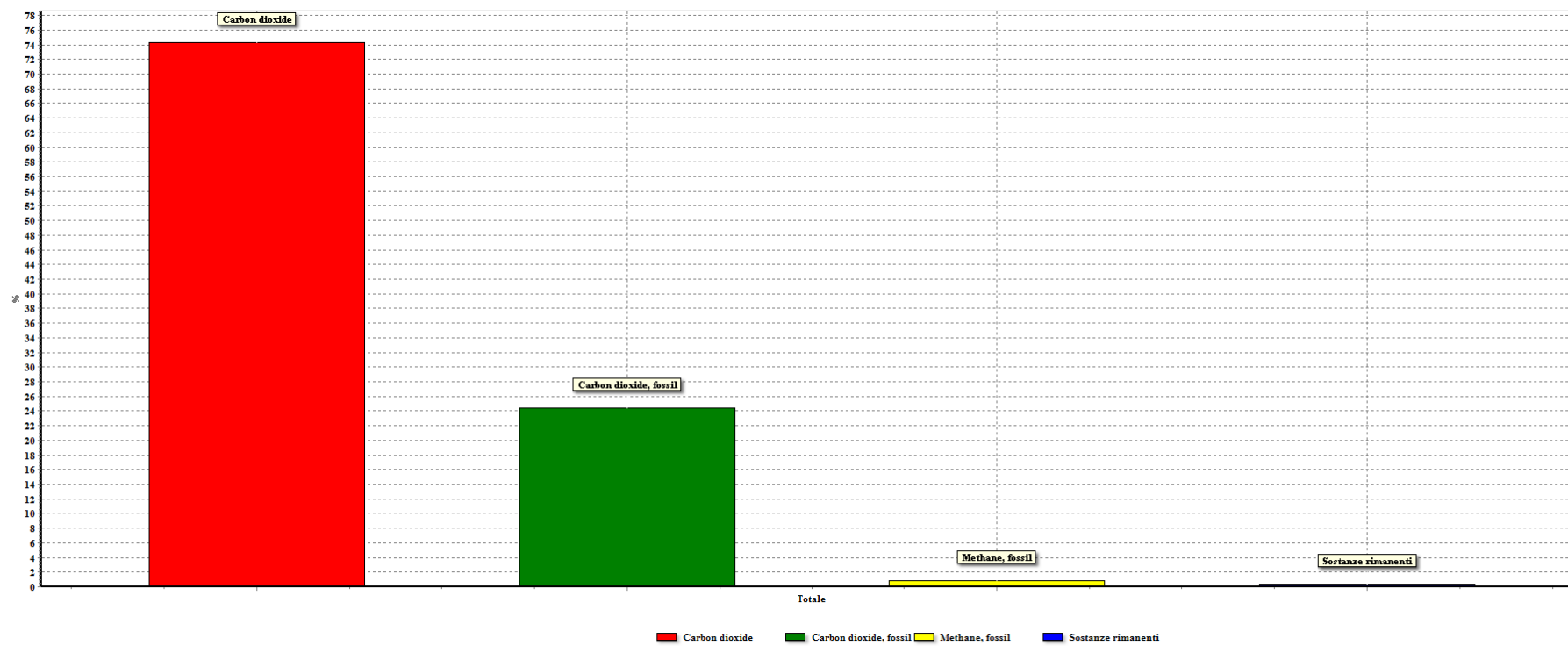

**Figure 39: Most contribution of GHGs (%) in I Phase - (FU: 1 ha sweet cherry orchard)**

Sustainability and innovation of the sweet cherry supply chain

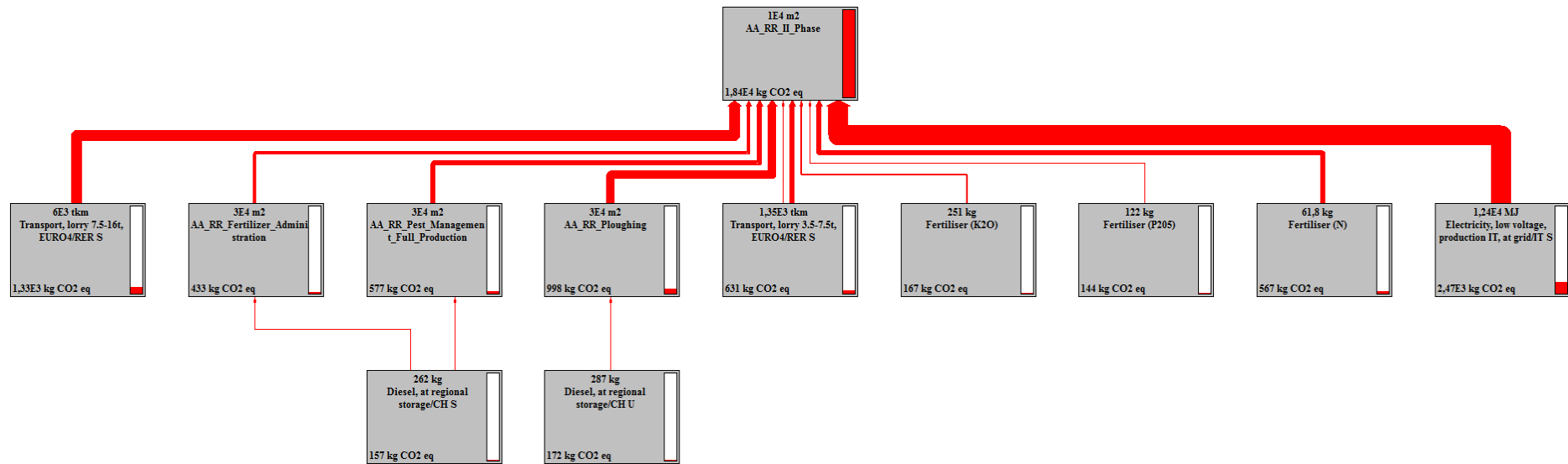

Figure 40: Sankey diagram (kgCO<sub>2</sub>eq) of II Phase - (FU: 1 ha sweet cherry orchard)

Sustainability and innovation of the sweet cherry supply chain

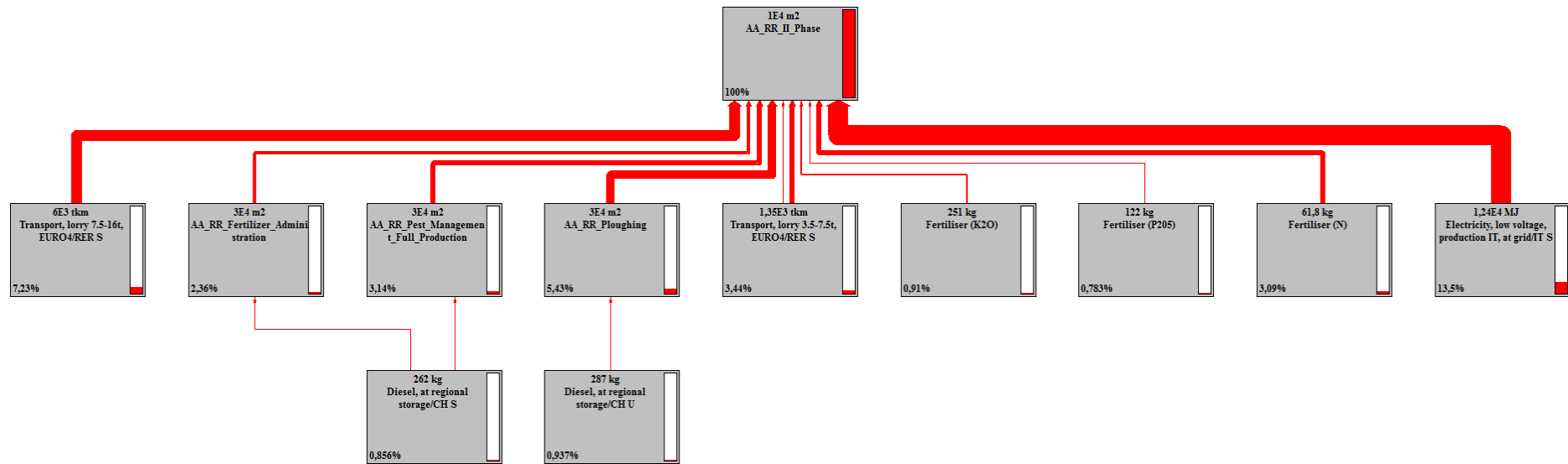

Figure 41: Sankey diagram (%) of II Phase - (FU: 1 ha sweet cherry orchard)

## Sustainability and innovation of the sweet cherry supply chain

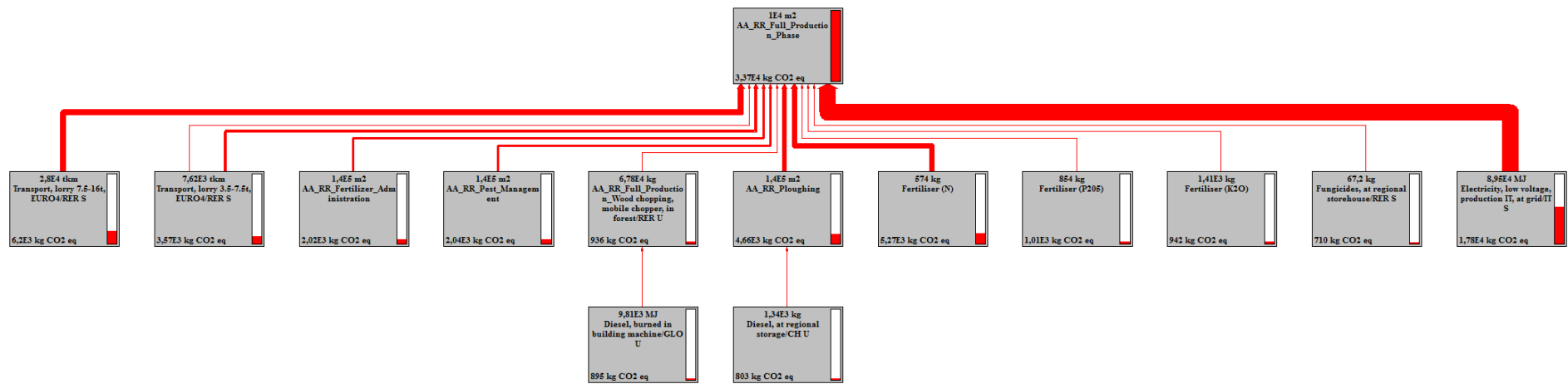

Figure 42: Sankey diagram (kgCO<sub>2</sub>eq) of II Phase - (FU: 1 ha sweet cherry orchard)

## Sustainability and innovation of the sweet cherry supply chain

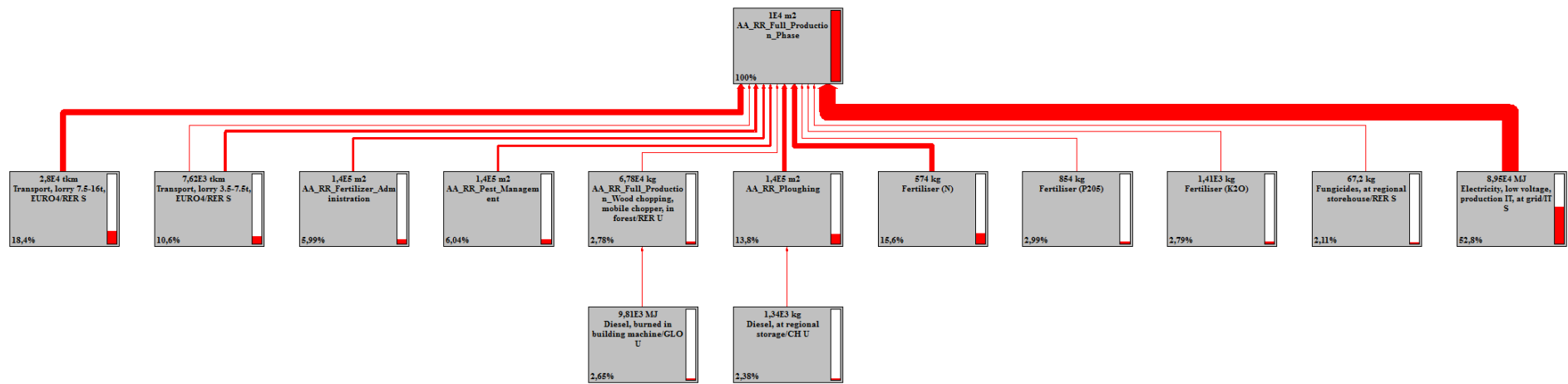
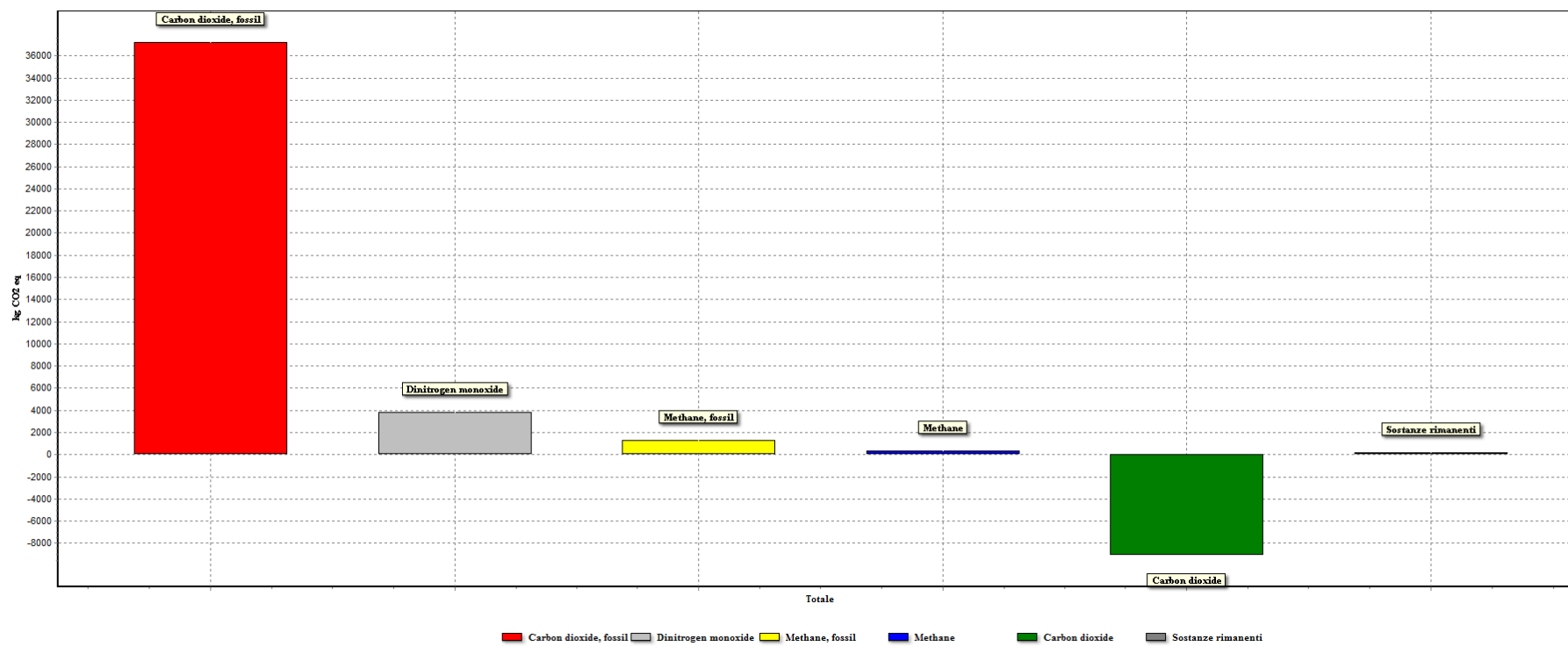

Figure 43: Sankey diagram (%) of Full Production Phase - (FU: 1 ha sweet cherry orchard)



Analizzando 1 ha 'AA\_RR\_Full\_Production\_Phase'; Metodo: IPCC 2007 GWP 100a V1.02 / Caratterizzazione

Figure 44: Most contribution of GHGs (kgCO<sub>2</sub>eq) in Full Production Phase - (FU: 1 ha sweet cherry orchard)

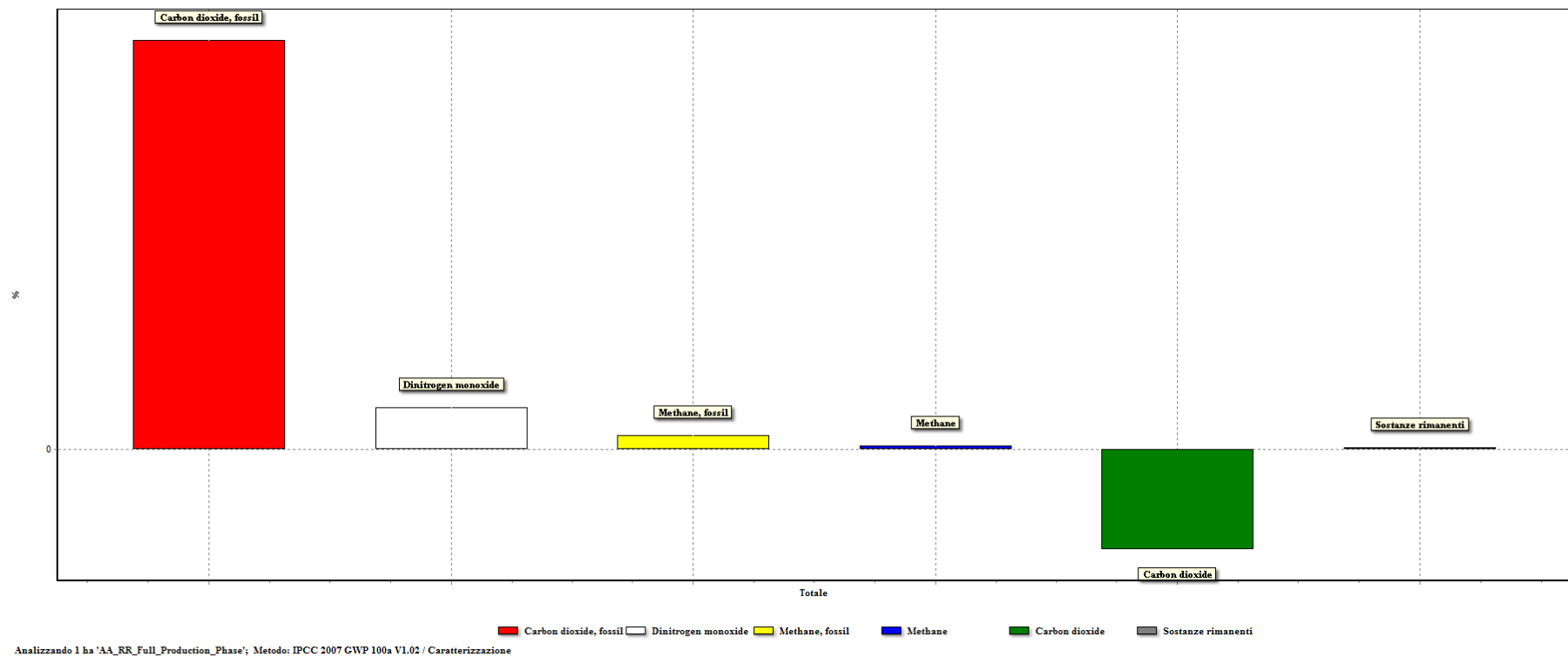

Figure 45: Most contribution of GHGs (%) in Full Production Phase - (FU: 1 ha sweet cherry orchard)

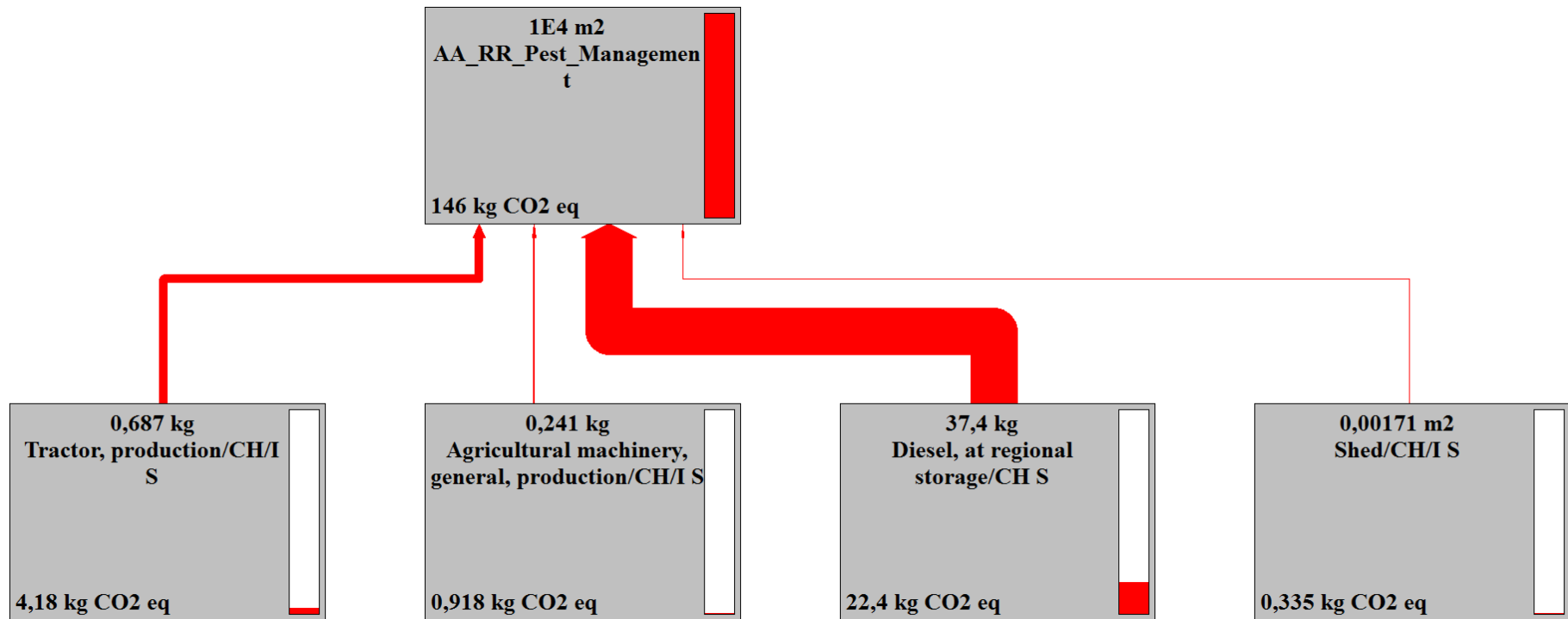

Figure 46: Sankey diagram (kgCO<sub>2eq</sub>) of Pest Management treatment - (FU: 1 ha sweet cherry orchard)



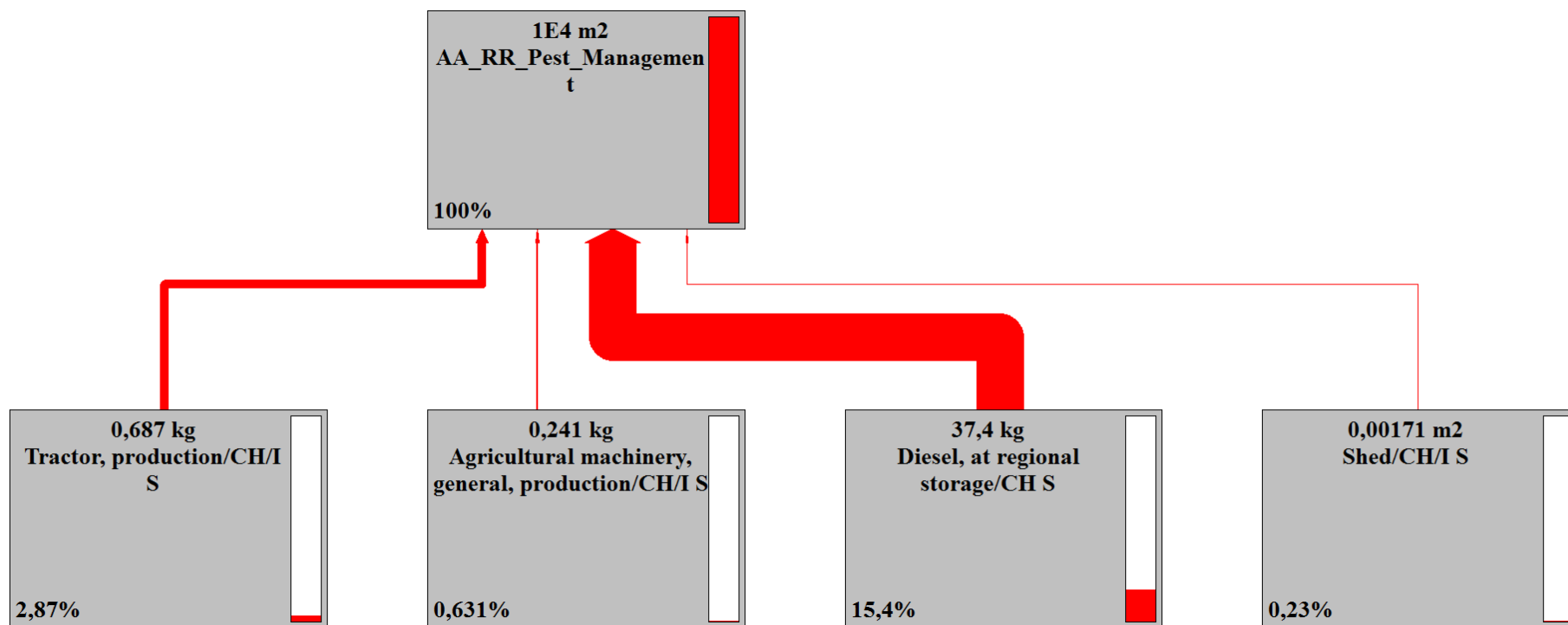

Figure 47: Sankey diagram (%) of Pest Management treatment - (FU: 1 ha sweet cherry orchard)

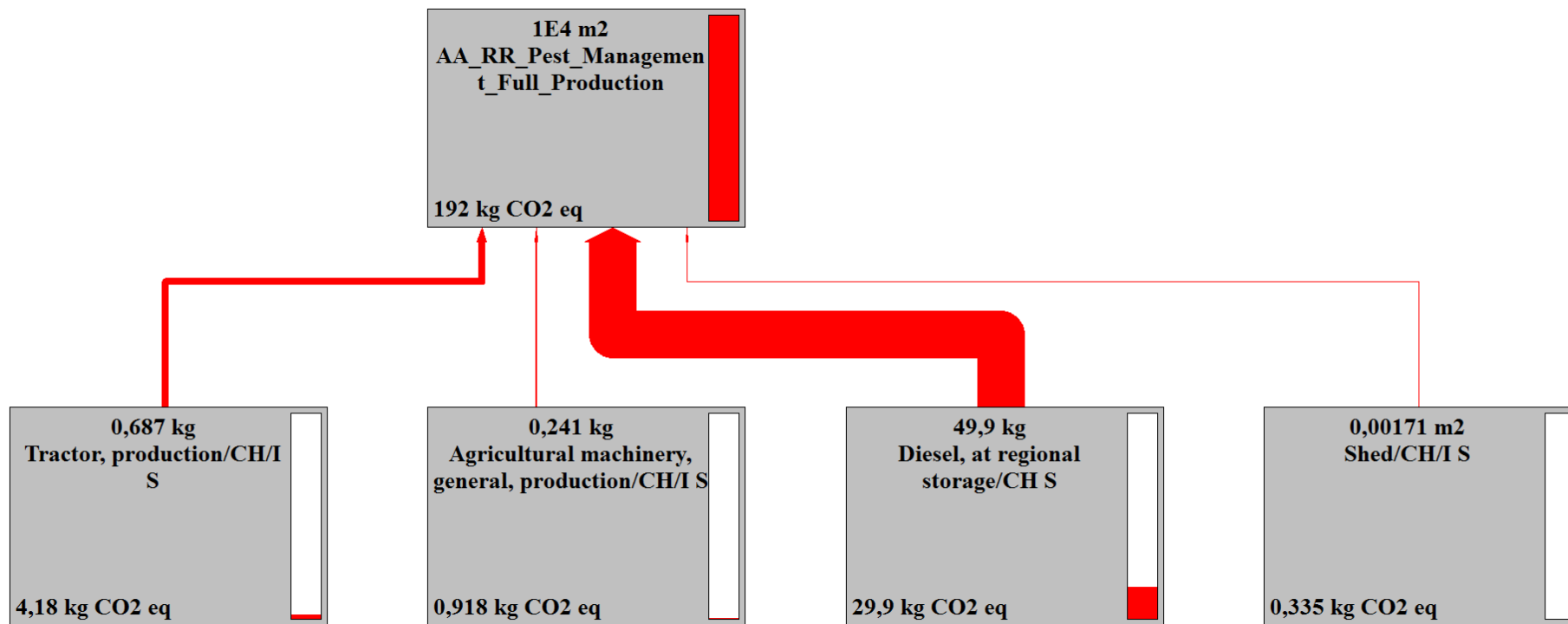

Figure 48: Sankey diagram (kgCO<sub>2</sub>eq) of Pest Management treatment in Full Production Phase - (FU: 1 ha sweet cherry orchard)

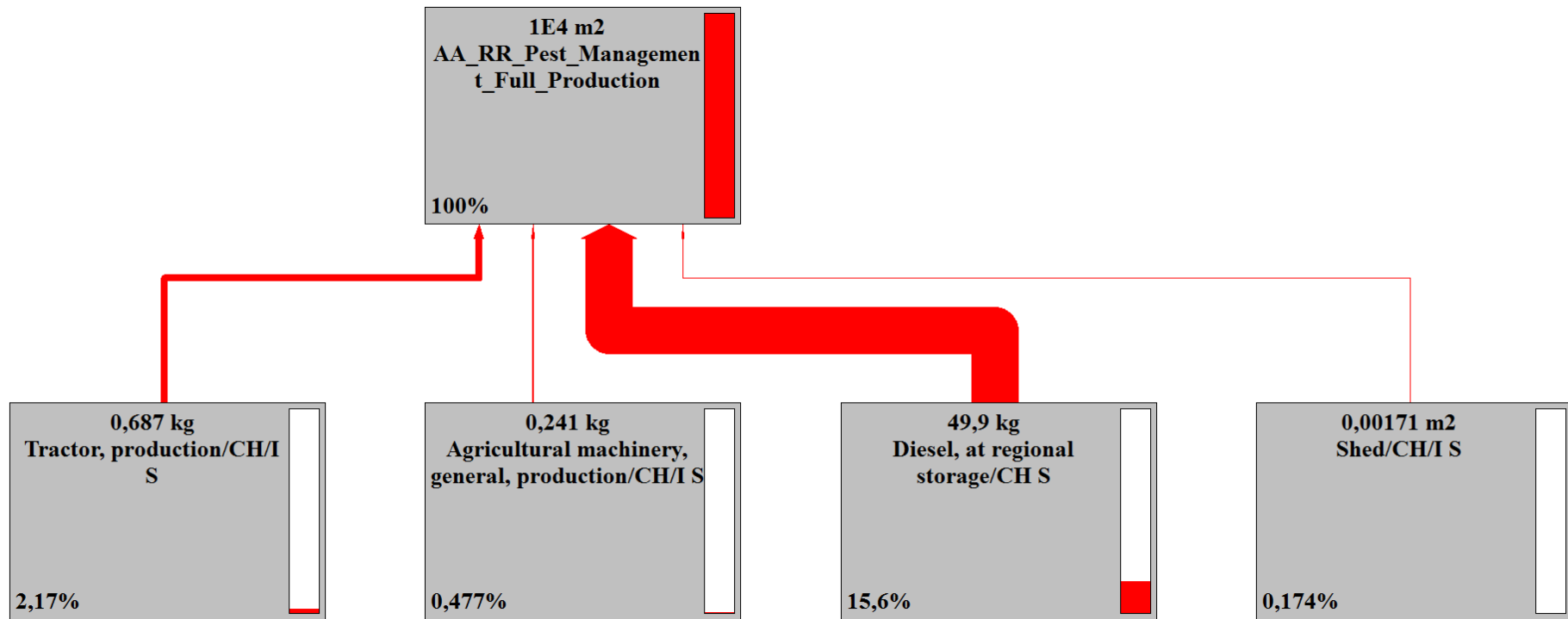

Figure 49: Sankey diagram (%) of Pest Management treatment in Full Production Phase - (FU: 1 ha sweet cherry orchard)

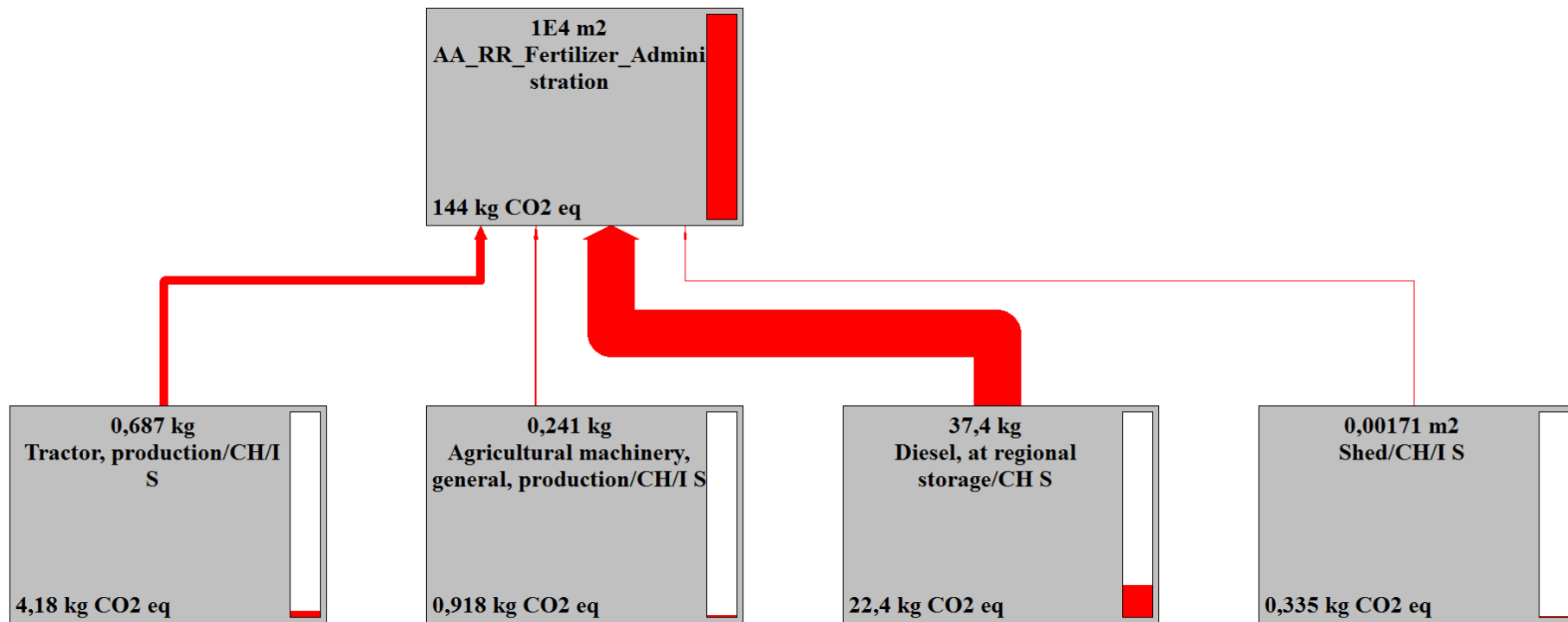

Figure 50: Sankey diagram (kgCO<sub>2eq</sub>) of Fertilizer administration - (FU: 1 ha sweet cherry orchard)

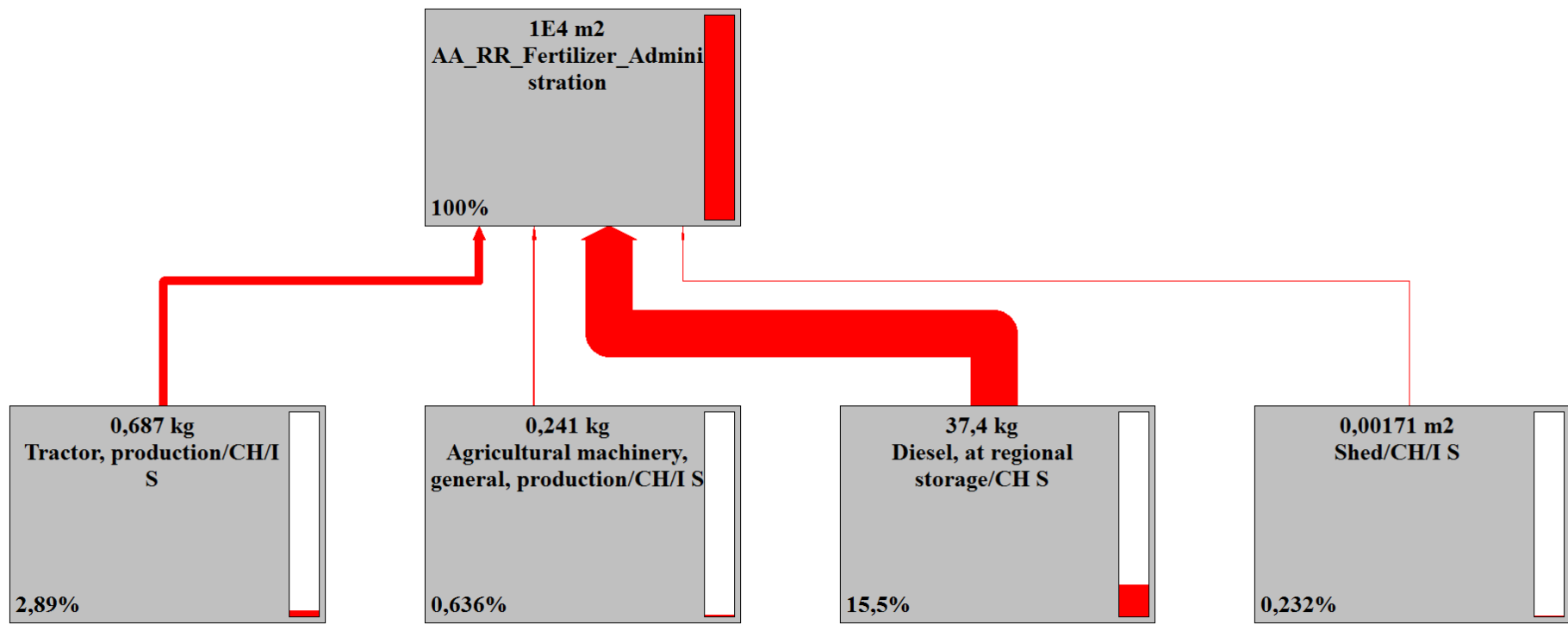
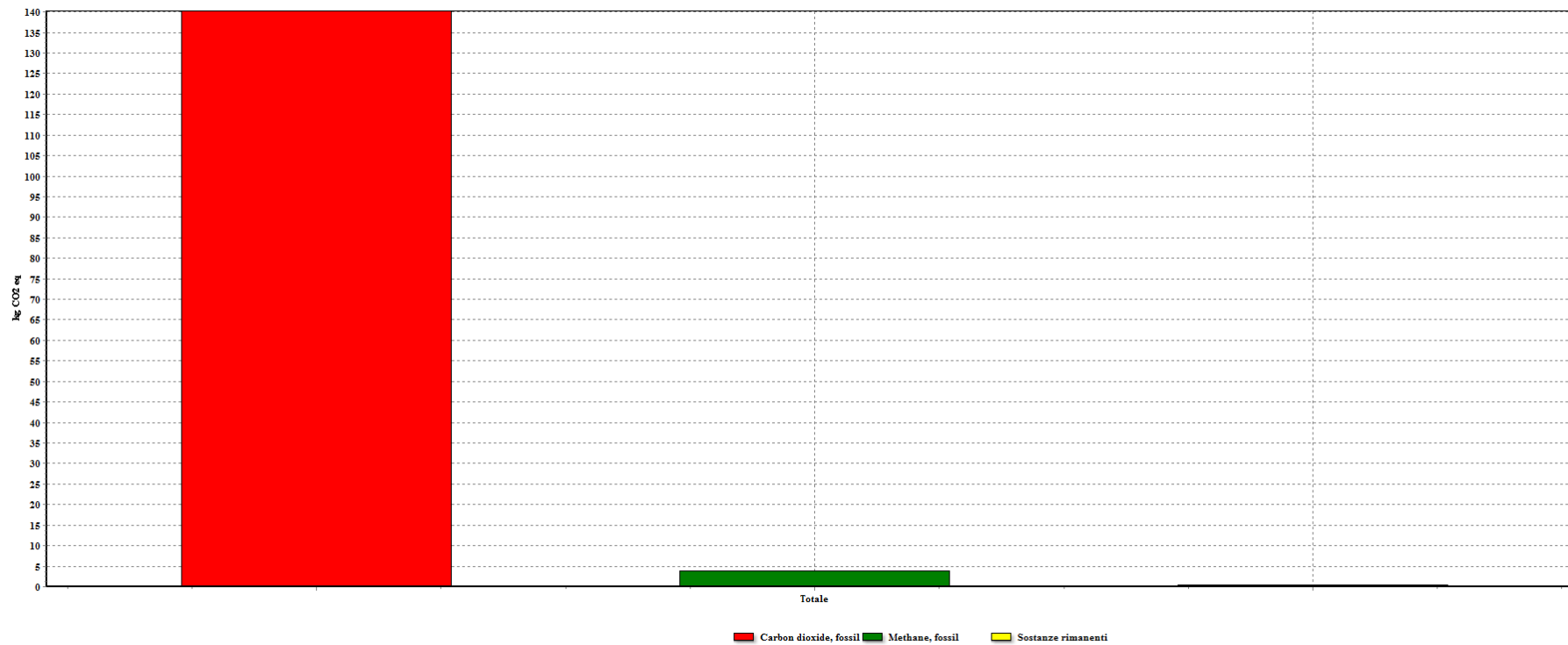

Figure 51: Sankey diagram (%) of Fertilizer administration - (FU: 1 ha sweet cherry orchard)

# Sustainability and innovation of the sweet cherry supply chain



Analizzando 1 ha 'AA\_RR\_Fertilizer\_Administration'; Metodo: IPCC 2007 GWP 100a V1.02 / Caratterizzazione

**Figure 52: Most contribution of GHGs (kgCO<sub>2</sub>eq) in Fertilizer treatment (FU: 1 ha sweet cherry orchard)**

## Sustainability and innovation of the sweet cherry supply chain

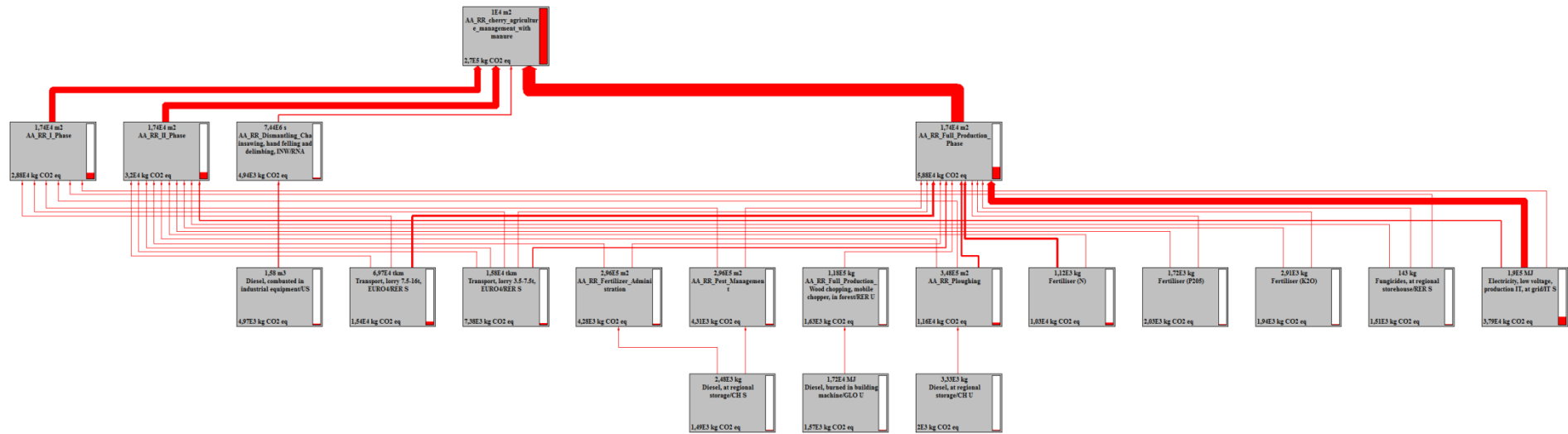

Figure 53: Sankey diagram (kgCO<sub>2</sub>eq) of cherry agriculture management with manure - (FU: 1 ha sweet cherry orchard)

## Sustainability and innovation of the sweet cherry supply chain

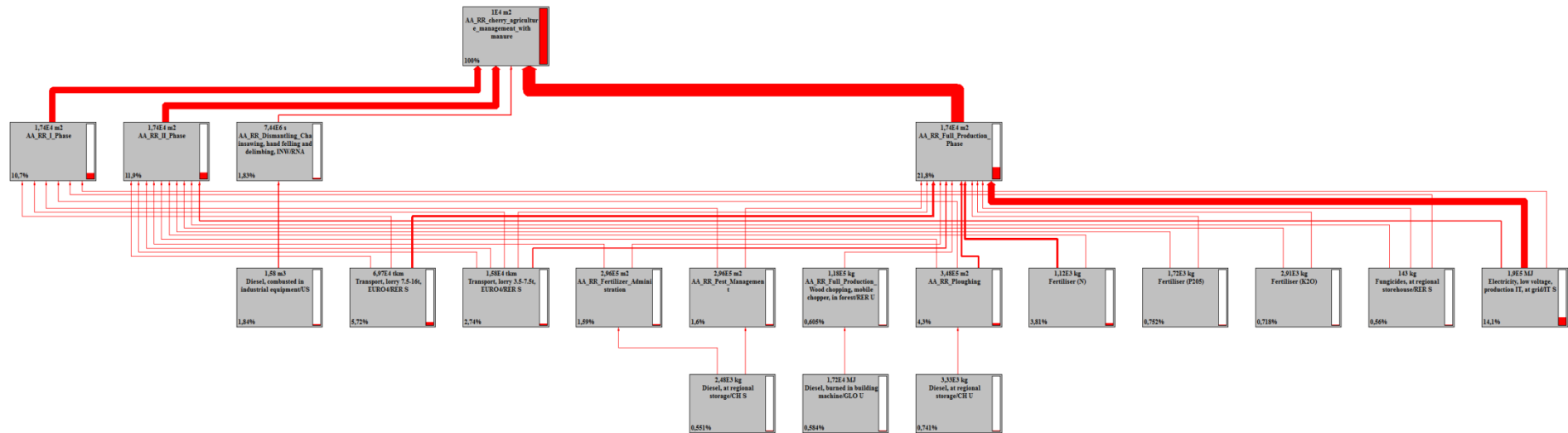
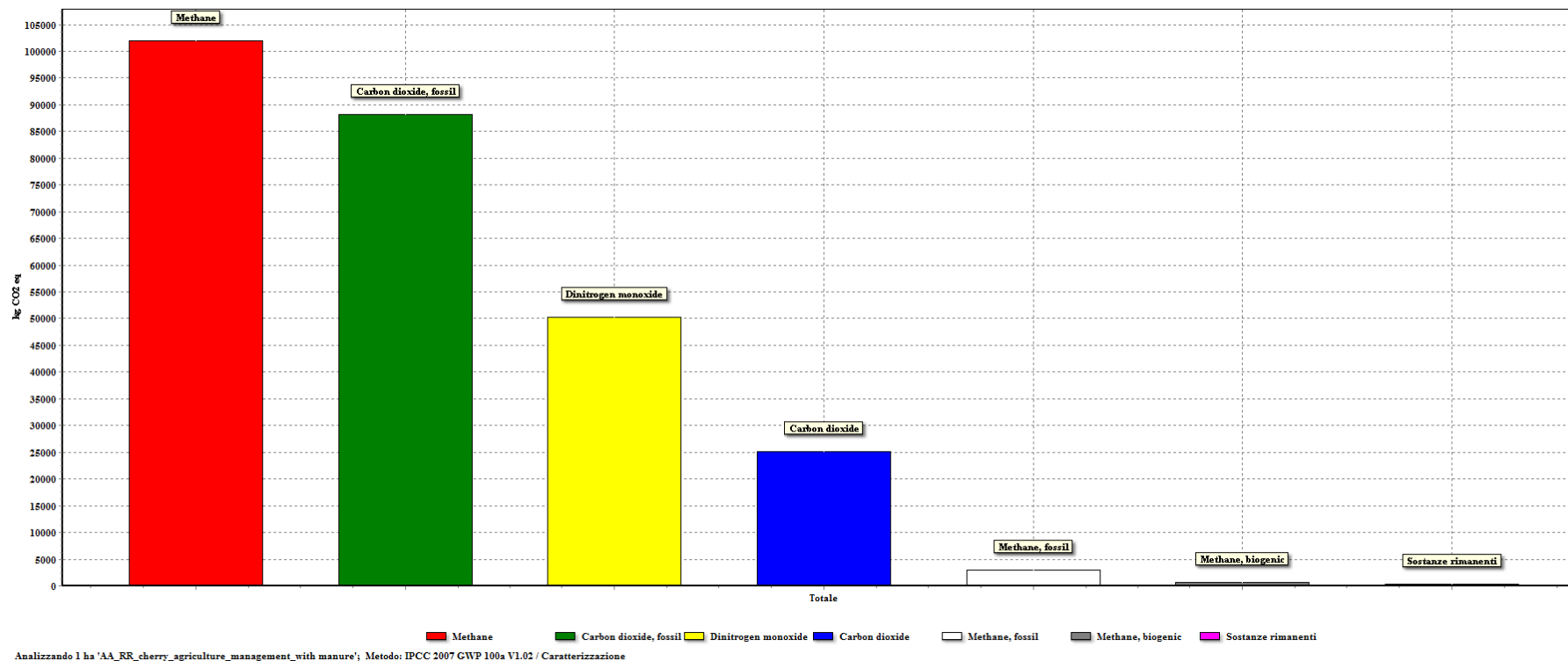

Figure 54: Sankey diagram (%) of cherry agriculture management with manure - (FU: 1 ha sweet cherry orchard)



## Sustainability and innovation of the sweet cherry supply chain



**Figure 55: Most contribution of GHGs (kgCO<sub>2</sub>eq) in cherry agriculture management with manure - (FU: 1 ha sweet cherry orchard)**

## Sustainability and innovation of the sweet cherry supply chain

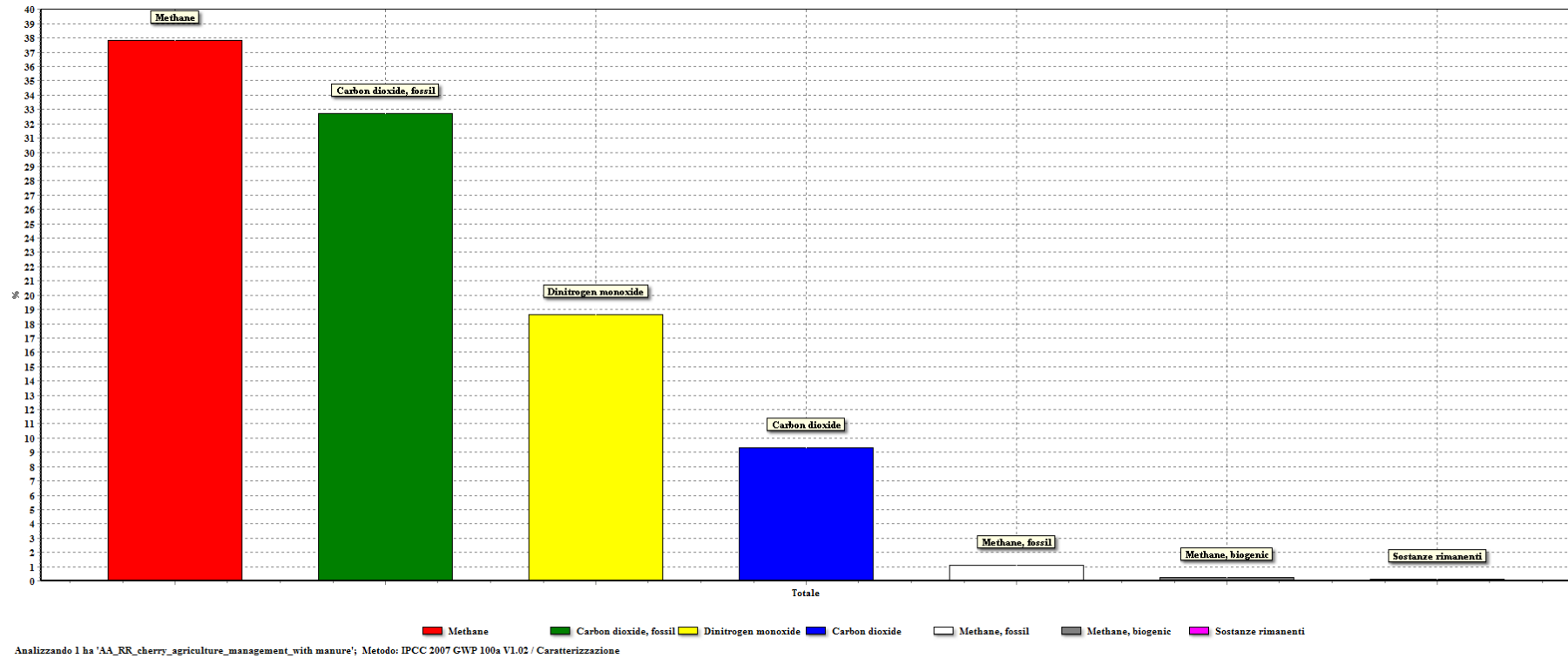

**Figure 56: Most contribution of GHGs (%) in cherry agriculture management with manure - (FU: 1 ha sweet cherry orchard)**

## Sustainability and innovation of the sweet cherry supply chain

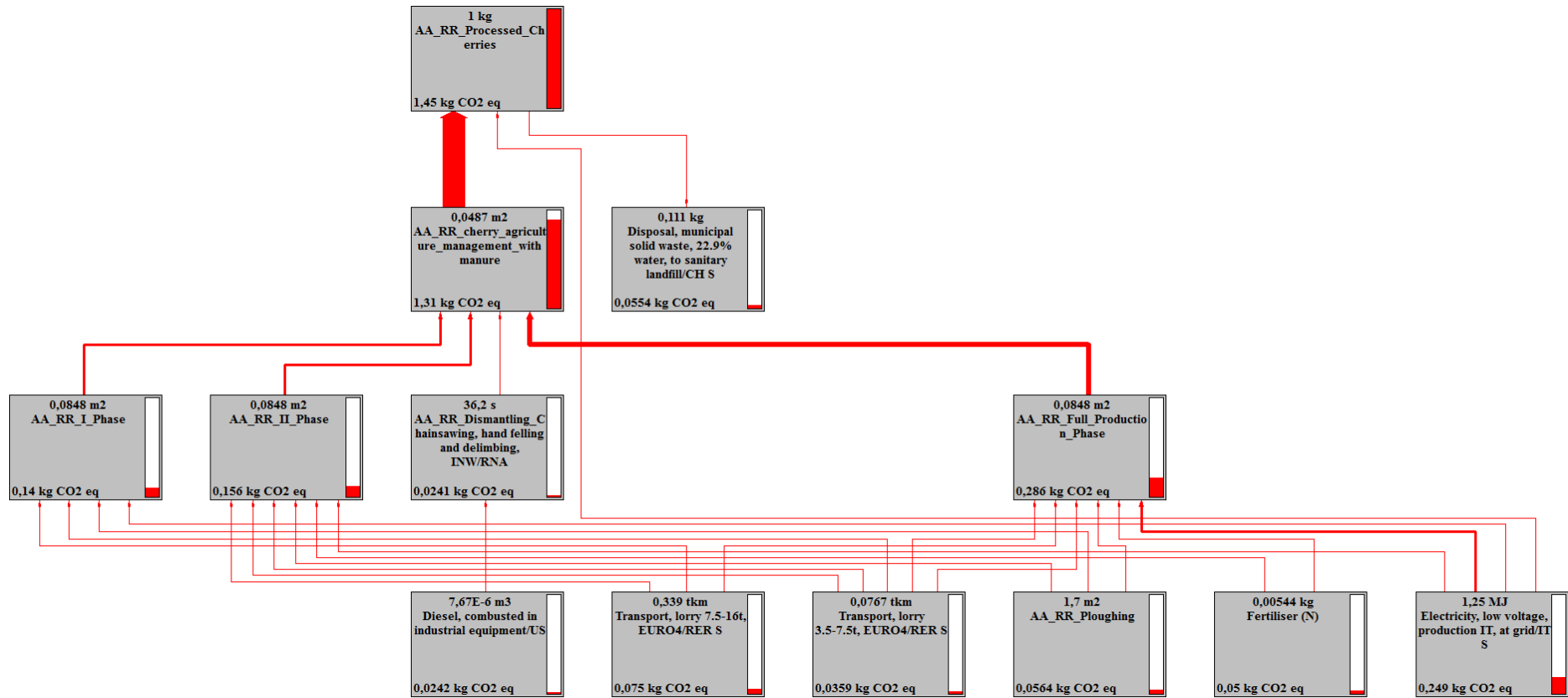

**Figure 57: Sankey diagram (kgCO<sub>2</sub>eq) of Processed Cherry Phase- (FU: 1 kg processed cherry)**

Sustainability and innovation of the sweet cherry supply chain

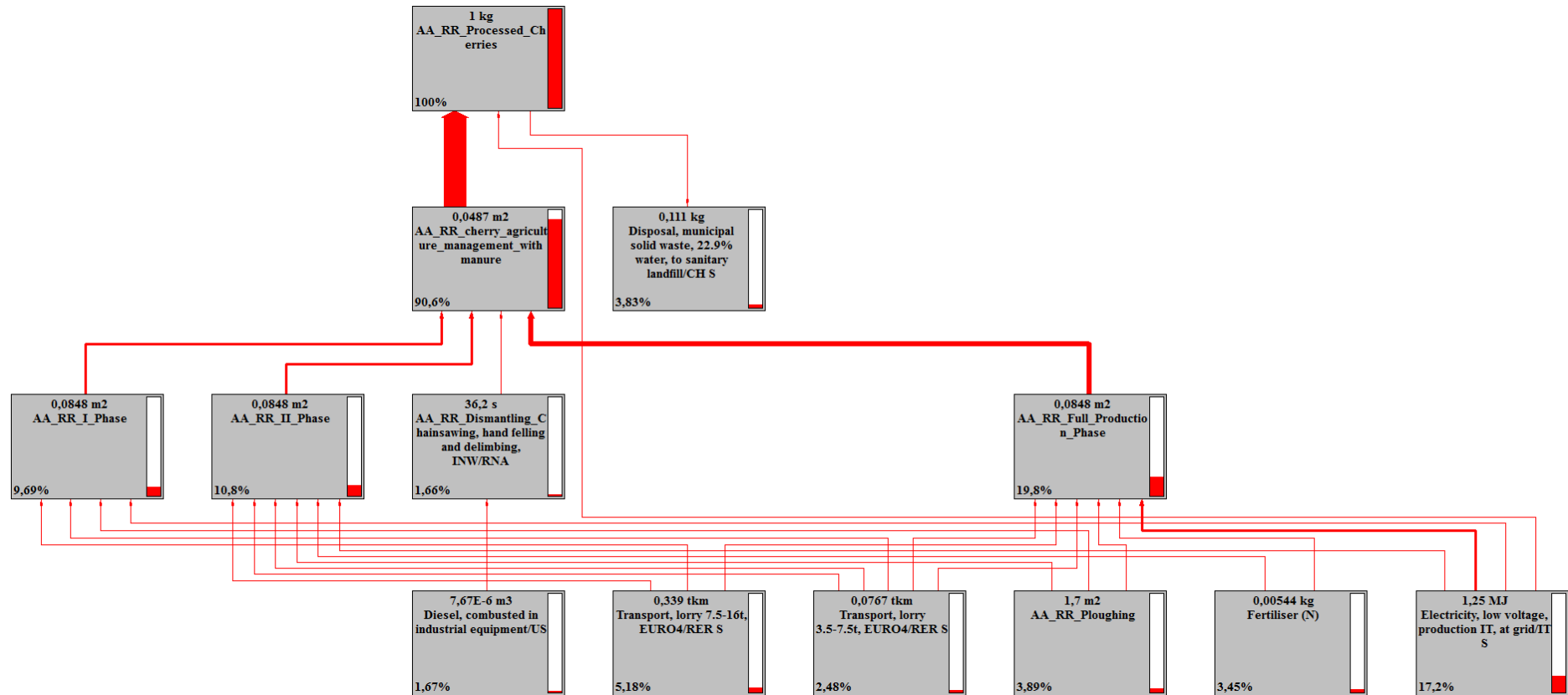

Figure 58: Sankey diagram (%) of Processed Cherry Phase - (FU: 1 ha sweet cherry orchard)

Sustainability and innovation of the sweet cherry supply chain

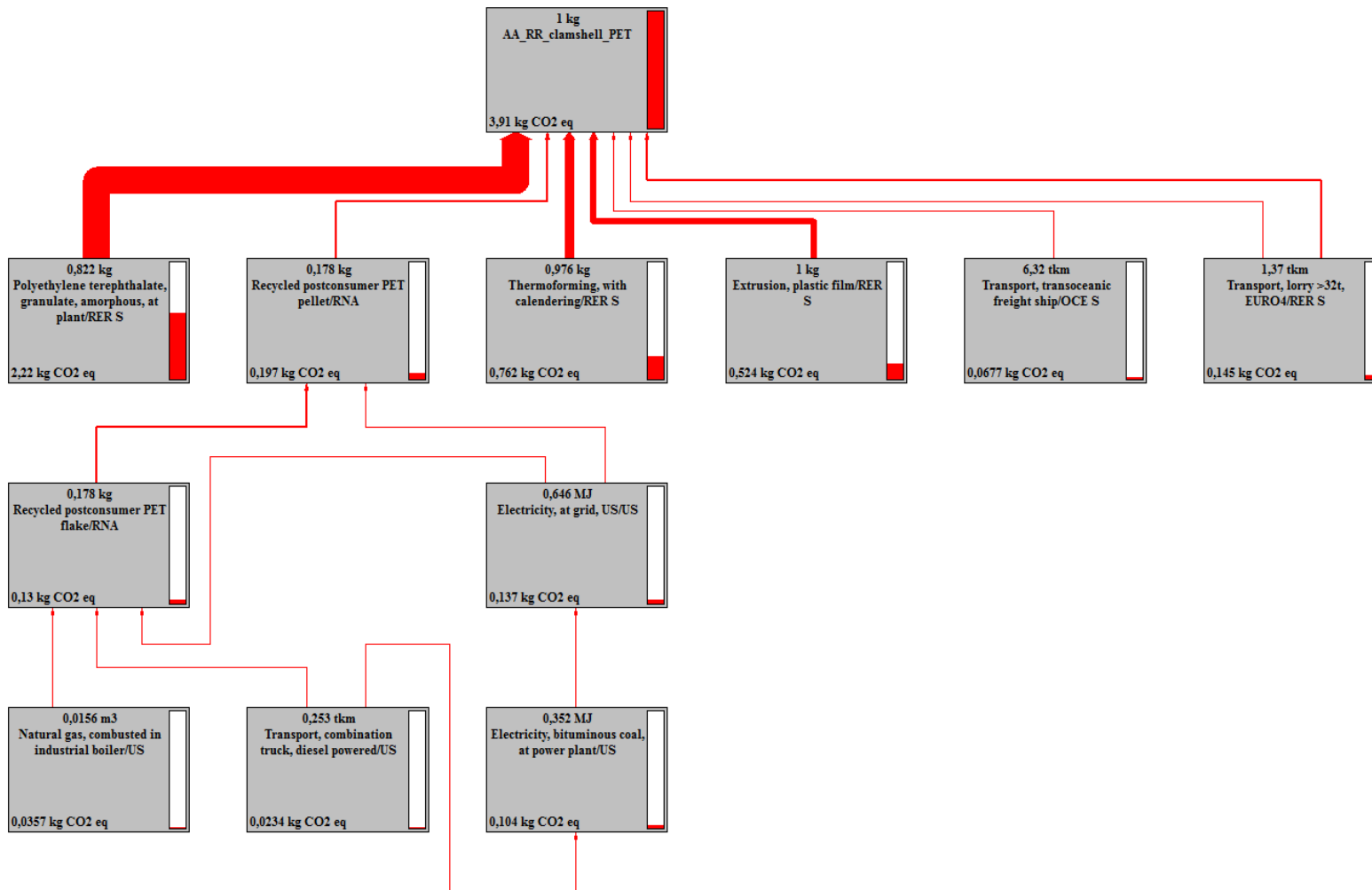

Figure 59: Sankey diagram (kgCO<sub>2</sub>eq) of PET clamshell Production- (FU: 1 kg PET clamshell)

Sustainability and innovation of the sweet cherry supply chain

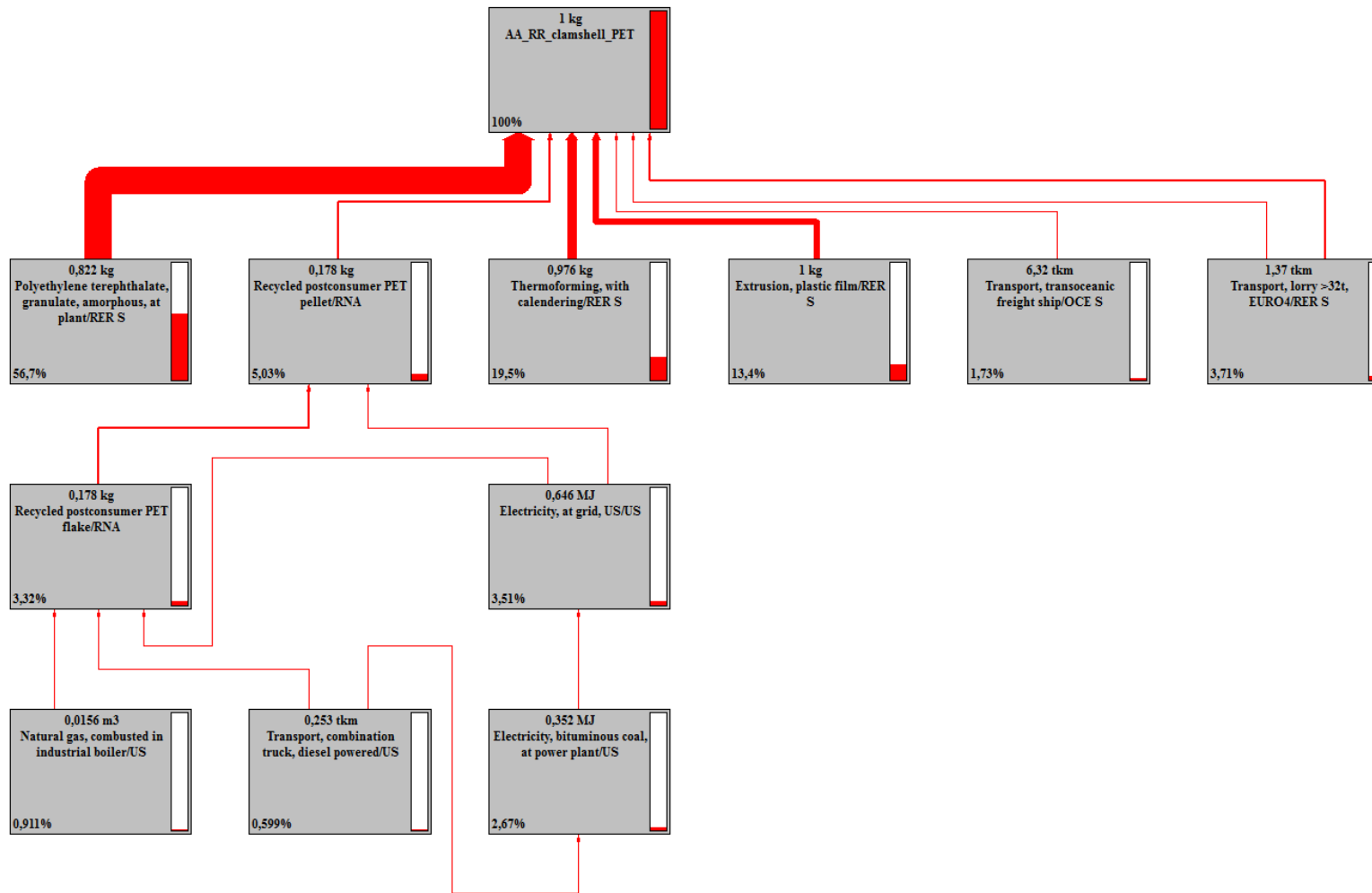
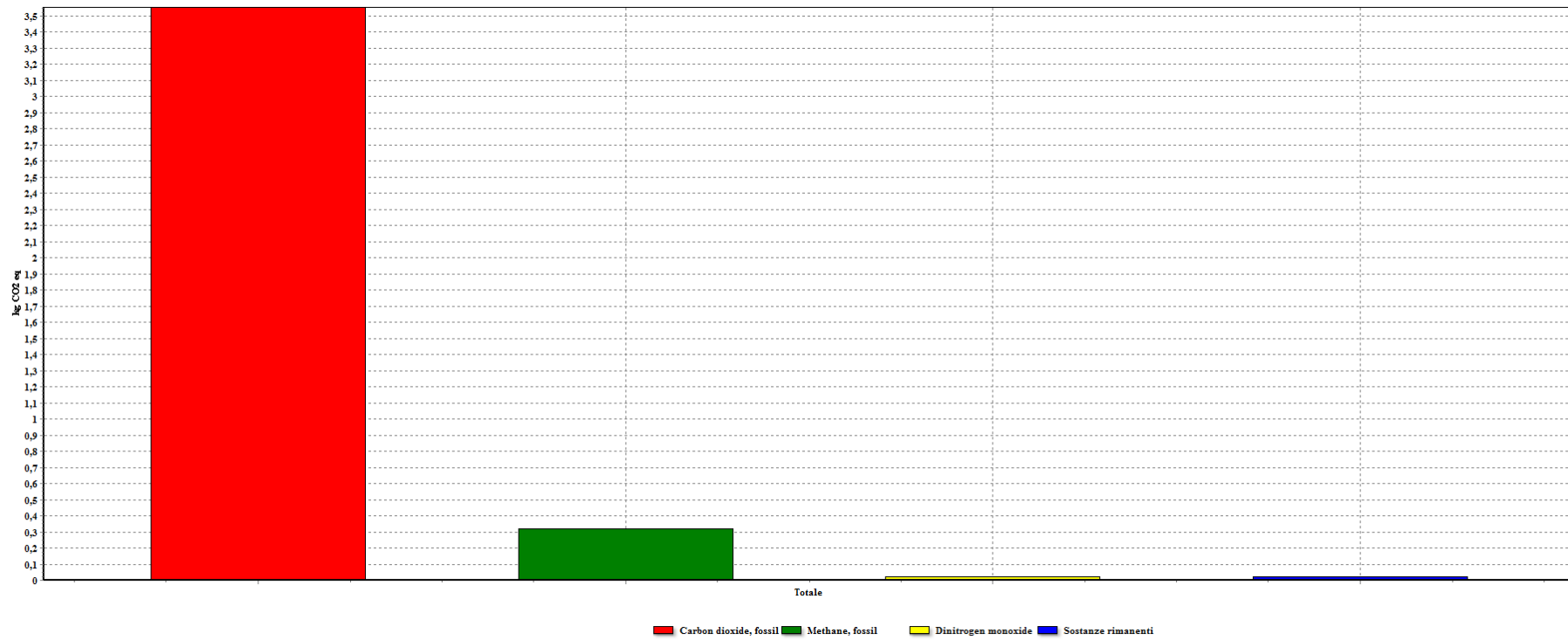

Figure 60: Sankey diagram (%) of PET clamshell Production - (FU: 1 kg PET clamshell)

## Sustainability and innovation of the sweet cherry supply chain



**Figure 61: Most contribution of GHGs (kgCO<sub>2</sub>eq) in PET clamshell Production Phase (FU: 1 kg PET clamshell)**

# Sustainability and innovation of the sweet cherry supply chain

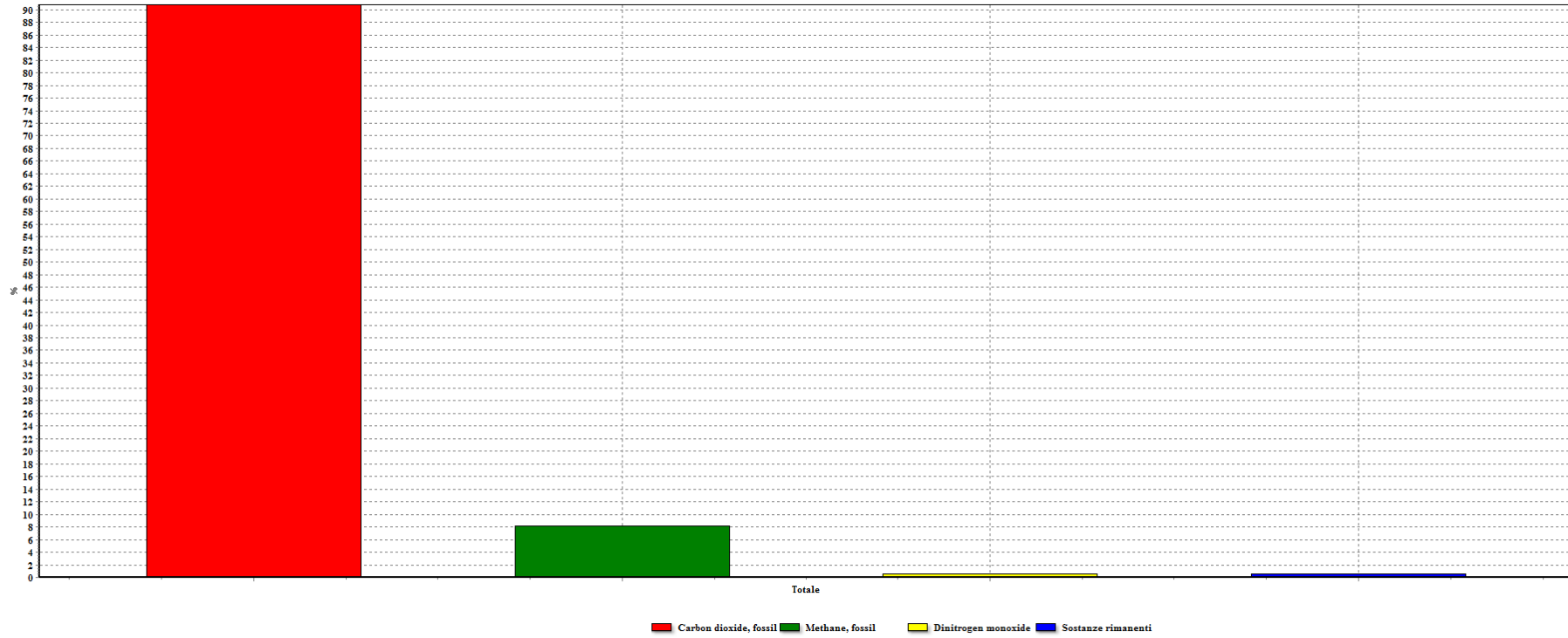

**Figure 62: Most contribution of GHGs (kgCO<sub>2</sub>eq) in PET clamshell Production Phase (FU: 1 kg PET clamshell)**







## Sustainability and innovation of the sweet cherry supply chain

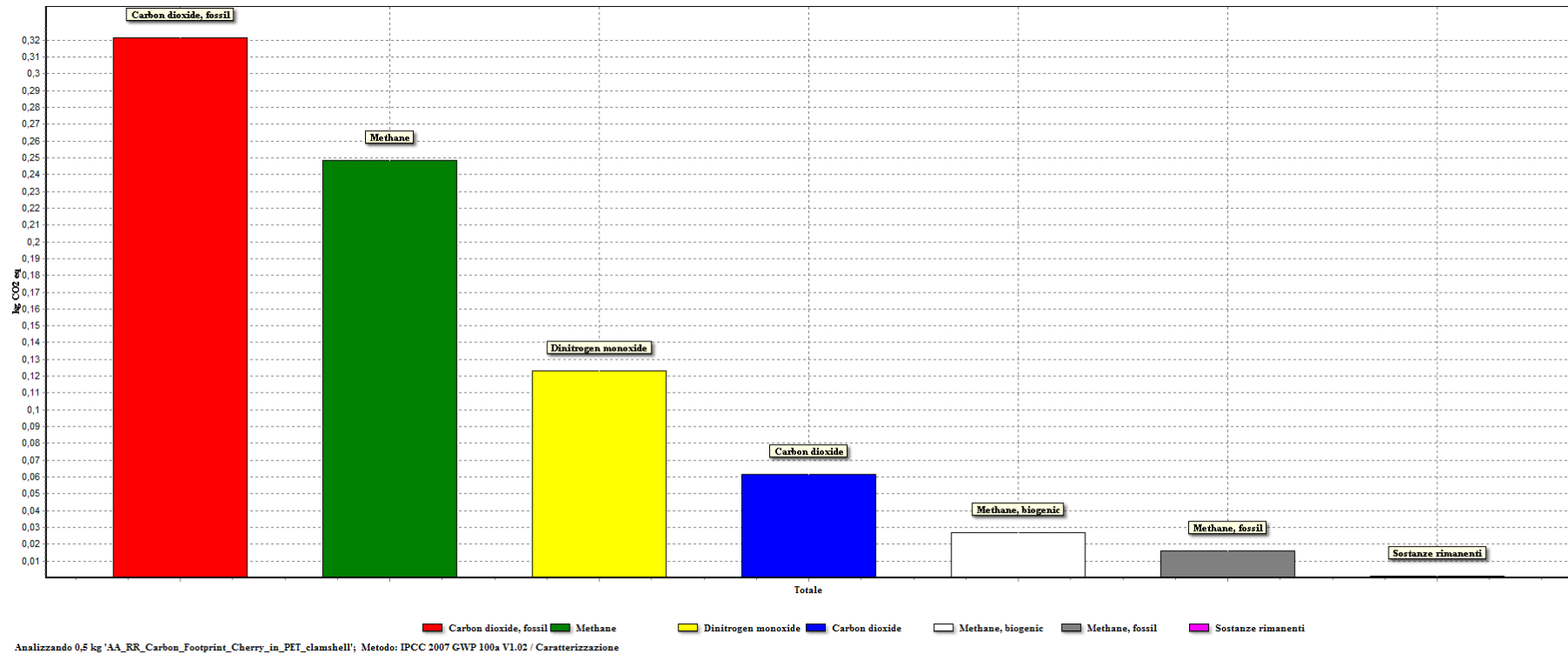

**Figure 65: Most contribution of GHGs (kgCO<sub>2</sub>eq) in cherries packed in PET clamshell Phase - (FU: 0.5 kg of cherry packed in PET clamshell)**

## Sustainability and innovation of the sweet cherry supply chain

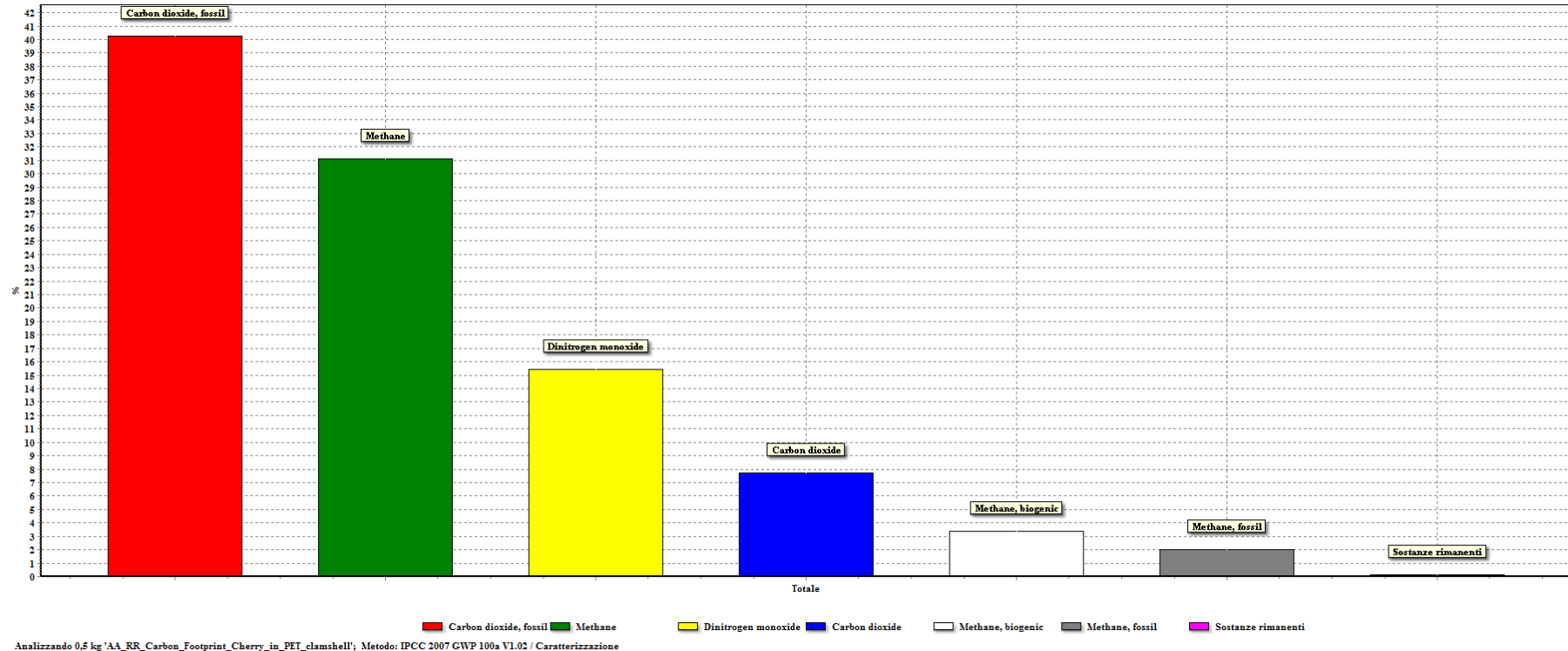

**Figure 66: Most contribution of GHGs (kgCO<sub>2eq</sub>) in cherries packed in PET clamshell Phase - (FU: 0.5 kg of cherry packed in PET clamshell)**

## List of symbols and abbreviations

BSI	British Standard Institute
CAP	Common Agricultural Policy
Cb	Carbon balance
CF	Carbon Footprint
CH <sub>4</sub>	Methane
CO <sub>2</sub>	Carbon Dioxide
CO <sub>2eq</sub>	Carbon Dioxide Equivalent
DEFRA	UK Department of Food and Rural Affair
EPA	Environmental Protection Agency
EU	European Union
FU	Functional Unit
GHG	Greenhouse Gas
GWP	Global Warming Potential
HFCs	Hydro-fluorocarbons compounds
IPCC	Intergovernmental Panel on Climate Change
ISO	International Organization for Standardization
LCI	Life Cycle Inventory
LCIA	Life Cycle Impact Assessment
LTC	Lateral transport of carbon
METI	Japan Trade and Industry

N <sub>2</sub> O	Nitrous oxide
NECB	Net Ecosystem Balance
NEP	Net ecosystem production
NPP	Net primary production
PAS	Publicly Available Specification
PCF	Product Carbon Footprint
PET	PolyEthylene Terephthalate
PFCs	Per-fluorocarbons - compounds
RDP	Rural Development Programme
SF <sub>6</sub>	Sulphur hexafluoride
UK	United Kingdom
USA	United State of America
WBCSD	World Business Council for Sustainable Development
WRI	World Resources Institute